

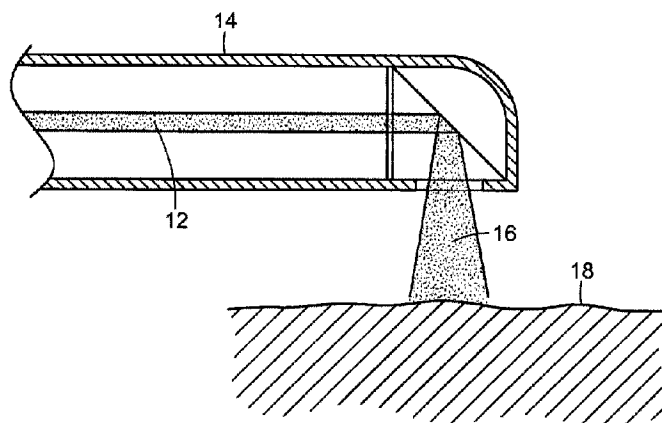

(22) Date de dépôt/Filing Date: 2015/11/16
 (41) Mise à la disp. pub./Open to Public Insp.: 2016/08/04
 (45) Date de délivrance/Issue Date: 2023/03/14
 (62) Demande originale/Original Application: 2 972 416
 (30) Priorités/Priorities: 2015/01/28 (US14/607,959);
 2015/04/28 (US62/153,616); 2015/10/26 (US14/922,885)

(51) Cl.Int./Int.Cl. *A61N 5/06* (2006.01),
A61B 18/20 (2006.01), *A61K 45/00* (2006.01),
A61P 27/02 (2006.01), *A61N 7/00* (2006.01)
 (72) Inventeurs/Inventors:
 LUTTRULL, JEFFREY K., US;
 MARGOLIS, BENJAMIN W. L., US;
 CHANG, DAVID B., US
 (73) Propriétaire/Owner:
 OJAI RETINAL TECHNOLOGY, LLC, US
 (74) Agent: GOWLING WLG (CANADA) LLP

(54) Titre : THERAPIE ELECTROMAGNETIQUE PULSEE ET PAR ULTRASONS POUR STIMULER DES PROTEINES DE CHOC THERMIQUE CIBLEES ET FACILITER UNE REPARATION DE PROTEINE
 (54) Title: PULSATING ELECTROMAGNETIC AND ULTRASOUND THERAPY FOR STIMULATING TARGETED HEAT SHOCK PROTEINS AND FACILITATING PROTEIN REPAIR



(57) **Abrégé/Abstract:**

A system and method are disclosed for stimulating activation of heat shock proteins and facilitating protein repair in cells and tissues in order to take advantage of the remediative and restorative nature of the increased heat shock protein activation or production and the facilitation of protein repair, while not damaging the cells and tissues. This is accomplished by treating a specified target area with an ultrasound or electromagnetic radiation source which is pulsed and applied or focused to one or more small areas in order to achieve the necessary temperature rise or sufficiently stress the cells and tissue to stimulate heat shock protein production or activation and facilitate protein repair, while allowing the temperature to decay sufficiently quickly so as not to damage or destroy the treated tissue.

Abstract

A system and method are disclosed for stimulating activation of heat shock proteins and facilitating protein repair in cells and tissues in order to take advantage of the remediative and restorative nature of the increased heat shock protein activation or production and the facilitation of protein repair, while not damaging the cells and tissues. This is accomplished by treating a specified target area with an ultrasound or electromagnetic radiation source which is pulsed and applied or focused to one or more small areas in order to achieve the necessary temperature rise or sufficiently stress the cells and tissue to stimulate heat shock protein production or activation and facilitate protein repair, while allowing the temperature to decay sufficiently quickly so as not to damage or destroy the treated tissue.

PULSATING ELECTROMAGNETIC AND ULTRASOUND THERAPY FOR STIMULATING TARGETED HEAT SHOCK PROTEINS AND FACILITATING PROTEIN REPAIR

BACKGROUND OF THE INVENTION

[Para 1] The present invention is generally directed to the activation of heat shock proteins and the facilitation of protein repair. More particularly, the present invention is directed to a system and method for selectively stimulating targeted heat shock protein activation or production and facilitating protein repair utilizing a pulsating electromagnetic or ultrasound energy source.

[Para 2] Heat shock proteins (HSPs) are a family of proteins that are produced by cells in response to exposure to stressful conditions. Production of high levels of heat shock proteins can be triggered by exposure to different kinds of environmental stress conditions, such as infection, inflammation, exercise, exposure of the cell to toxins, starvation, hypoxia, or water deprivation.

[Para 3] It is known that heat shock proteins play a role in responding to a large number of abnormal conditions in body tissues, including viral infection, inflammation, malignant transformations, exposure to oxidizing agents, cytotoxins, and anoxia. Several heat shock proteins function as intra-cellular chaperones for other proteins and members of the HSP family are expressed or activated at low to moderate levels because of their essential role in protein maintenance and simply monitoring the cell's proteins even under non-

stressful conditions. These activities are part of a cell's own repair system, called the cellular stress response or the heat-shock response.

[Para 4] Heat shock proteins are typically named according to their molecular weight. For example, Hsp60, Hsp70 and Hsp80 refer to the families of heat shock proteins on the order of 60, 70 and 80 kilodaltons in size, respectively. They act in a number of different ways. For example, Hsp70 has peptide-binding and ATPase domains that stabilize protein structures in unfolded and assembly-competent states. Mitochondrial Hsp60s form ring-shaped structures facilitating the assembly of proteins into native states. Hsp90 plays a suppressor regulatory role by associating with cellular tyrosine kinases, transcription factors, and glucocorticoid receptors. Hsp27 suppresses protein aggregation.

[Para 5] Hsp70 heat shock proteins are a member of extracellular and membrane bound heat-shock proteins which are involved in binding antigens and presenting them to the immune system. Hsp70 has been found to inhibit the activity of influenza A virus ribonucleoprotein and to block the replication of the virus. Heat shock proteins derived from tumors elicit specific protective immunity. Experimental and clinical observations have shown that heat shock proteins are involved in the regulation of autoimmune arthritis, type 1 diabetes, mellitus, arterial sclerosis, multiple sclerosis, and other autoimmune reactions.

[Para 6] Accordingly, it is believed that it is advantageous to be able to selectively induce the heat shock response in order to increase the number or activity of heat shock proteins in body tissue in response to infection or other

abnormalities. However, this must be done in a controlled manner in order not to damage or destroy the tissue or the area of the body being treated. The present invention fulfills these needs, and provides other related advantages.

SUMMARY OF THE INVENTION

[Para 7] The present invention is directed to a method for stimulating heat shock protein activation in tissue without damaging the target tissue. The method comprises the steps of providing a source of pulsed ultrasound or electromagnetic energy. The electromagnetic energy may comprise ultraviolet waves, microwaves, radio frequency waves or laser light at a predetermined wavelength. The laser light may have a wavelength between 530nm to 1300 nm, a duty cycle of less than 10% and a pulse length of 500 milliseconds or less.

[Para 8] The pulsed ultrasound or electromagnetic radiation energy is applied to the target tissue to create a thermal time-course that stimulates cells of the target tissue to activate heat shock proteins without damaging the target tissue. This includes raising the target tissue temperature to at least 10°C transiently, while only 1°C or less over several minutes.

[Para 9] In one embodiment, a plurality of laser light spots are simultaneously applied to the target tissue. In another embodiment, a plurality of ultrasound beams are focused on the target tissue.

[Para 10] A device may be inserted into a cavity of the body in order to apply the pulsed ultrasound or electromagnetic radiation energy to the tissue. The device may comprise an endoscope.

[Para 11] The pulsed ultrasound or electromagnetic radiation energy may be applied to an exterior area of a body which is adjacent to the target tissue, or has a blood supply close to a surface of the exterior area of the body. For example, the body area may comprise an earlobe and the pulse electromagnetic radiation energy is applied to the blood flowing through the earlobe.

[Para 12] Other features and advantages of the present invention will become apparent from the following more detailed description, taken in conjunction with the accompanying drawings, which illustrate, by way of example, the principles of the invention.

BRIEF DESCRIPTION OF THE DRAWINGS

[Para 13] The accompanying drawings illustrate the invention. In such drawings:

[Para 14] FIGURE 1 is a diagrammatic view of a light generating unit that produces timed series of pulses, having a light pipe extending therefrom, in accordance with the present invention;

[Para 15] FIGURE 2 is a cross-sectional view of a photostimulation delivery device delivering electromagnetic energy to target tissue, in accordance with the present invention;

[Para 16] FIGURE 3 is a diagrammatic view illustrating a system used to generate a laser light beam, in accordance with the present invention;

[Para 17] FIGURE 4 is a diagrammatic view of optics used to generate a laser light geometric pattern, in accordance with the present invention;

[Para 18] FIGURE 5 is a diagrammatic view illustrating an alternate embodiment of the system used to generate laser light beams for treating tissue, in accordance with the present invention;

[Para 19] FIGURE 6 is a diagrammatic view illustrating yet another embodiment of a system used to generate laser light beams to treat tissue in accordance with the present invention;

[Para 20] FIGURE 7 is a cross-sectional and diagrammatic view of an end of an endoscope inserted into the nasal cavity and treating tissue therein, in accordance with the present invention;

[Para 21] FIGURE 8 is a diagrammatic and partially cross-sectioned view of a bronchoscope extending through the trachea and into the bronchus of a lung and providing treatment thereto, in accordance with the present invention;

[Para 22] FIGURE 9 is a diagrammatic view of a colonoscope providing photostimulation to an intestinal or colon area of the body, in accordance with the present invention;

[Para 23] FIGURE 10 is a diagrammatic view of an endoscope inserted into a stomach and providing treatment thereto, in accordance with the present invention;

[Para 24] FIGURE 11 is a partially sectioned perspective view of a capsule endoscope, used in accordance with the present invention;

[Para 25] FIGURE 12 is a diagrammatic view of a pulsed high intensity focused ultrasound for treating tissue internal the body, in accordance with the present invention;

[Para 26] FIGURE 13 is a diagrammatic view for delivering therapy to the bloodstream of a patient, through an earlobe, in accordance with the present invention; and

[Para 27] FIGURE 14 is a cross-sectional view of a stimulating therapy device of the present invention used in delivering photostimulation to the blood, via an earlobe, in accordance with the present invention.

DETAILED DESCRIPTION OF THE PREFERRED EMBODIMENTS

[Para 28] As shown in the accompanying drawings, and as more fully described herein, the present invention is directed to a system and method for delivering an energy source, such as laser, ultrasound, ultraviolet radiofrequency, microwave radiofrequency and the like, to cause a pulsing thermal time-course in tissue that stimulates heat shock protein activation or production and facilitates protein repair without causing any damage.

[Para 29] The inventors of the present invention have discovered that applying electromagnetic radiation, in the form of various wavelengths of laser light, to retinal tissue in a manner that does not destroy or damage the retinal tissue has achieved beneficial effects on eye diseases. It is believed that this

may be due, at least in part, to the stimulation and activation of heat shock proteins and the facilitation of protein repair in the retinal tissue. This is disclosed in United States patent application serial numbers 14/607,959 filed January 28, 2015, 13/798,523 filed March 13, 2013, and 13/481,124 filed May 25, 2012.

[Para 30] The inventors have found that a laser light beam can be generated that is therapeutic, yet sublethal to retinal tissue cells and thus avoids damaging photocoagulation in the retinal tissue which provides preventative and protective treatment of the retinal tissue of the eye. The inventors have discovered that generating a subthreshold, sublethal micropulse laser light beam which has a wavelength greater than 532nm and a duty cycle of less than 10% at a predetermined intensity or power and a predetermined pulse length or exposure time creates desirable retinal photostimulation without any visible burn areas or tissue destruction. More particularly, a laser light beam having a wavelength of between 550nm-1300nm, and in a particularly preferred embodiment 810nm, having a duty cycle of approximately 5% or less and a predetermined intensity or power (such as between 100-590 watts per square centimeter at the retina or approximately 1 watt per laser spot for each treatment spot at the retina) and a predetermined pulse length or exposure time (such as 500 milliseconds or less) creates a sublethal, "true subthreshold" retinal photostimulation in which all areas of the retinal pigment epithelium exposed to the laser irradiation are preserved and available to contribute

therapeutically. In other words, the inventors have found that raising the retinal tissue at least up to a therapeutic level but below a cellular or tissue lethal level recreates the benefit of the halo effect of the prior art methods without destroying, burning or otherwise damaging the retinal tissue. This is referred to herein as subthreshold diode micropulse laser treatment (SDM).

[Para 31] As SDM does not produce laser-induced retinal damage (photocoagulation), and has no known adverse treatment effect, and has been reported to be an effective treatment in a number of retinal disorders (including diabetic macular edema (DME) proliferative diabetic retinopathy (PDR), macular edema due to branch retinal vein occlusion (BRVO), central serous chorioretinopathy (CSR), reversal of drug tolerance, and prophylactic treatment of progressive degenerative retinopathies such as dry age-related macular degeneration, Stargardts' disease, cone dystrophies, and retinitis pigmentosa. The safety of SDM is such that it may be used transfoveally in eyes with 20/20 visual acuity to reduce the risk of visual loss due to early fovea-involving DME.

[Para 32] A mechanism through which SDM might work is the generation or activation of heat shock proteins (HSPs). Despite a near infinite variety of possible cellular abnormalities, cells of all types share a common and highly conserved mechanism of repair: heat shock proteins (HSPs). HSPs are elicited almost immediately, in seconds to minutes, by almost any type of cell stress or injury. In the absence of lethal cell injury, HSPs are extremely effective at repairing and returning the viable cell toward a more normal functional state. Although HSPs are transient, generally peaking in hours and persisting for a few

days, their effects may be long lasting. HSPs reduce inflammation, a common factor in many disorders.

[Para 33] Laser treatment can induce HSP production or activation and alter cytokine expression. The more sudden and severe the non-lethal cellular stress (such as laser irradiation), the more rapid and robust HSP activation. Thus, a burst of repetitive low temperature thermal spikes at a very steep rate of change (~ 7°C elevation with each 100µs micropulse, or 70,000°C/sec) produced by each SDM exposure is especially effective in stimulating activation of HSPs, particularly compared to non-lethal exposure to subthreshold treatment with continuous wave lasers, which can duplicate only the low average tissue temperature rise.

[Para 34] Laser wavelengths below 550nm produce increasingly cytotoxic photochemical effects. At 810nm, SDM produces photothermal, rather than photochemical, cellular stress. Thus, SDM is able to affect the tissue without damaging it. The clinical benefits of SDM are thus primarily produced by sub-morbid photothermal cellular HSP activation. In dysfunctional cells, HSP stimulation by SDM results in normalized cytokine expression, and consequently improved structure and function. The therapeutic effects of this “low-intensity” laser/tissue interaction are then amplified by “high-density” laser application, recruiting all the dysfunctional cells in the targeted tissue area by densely / confluent treatment of a large tissue area, including all areas of pathology, thereby maximizing the treatment effect. These principles define the treatment strategy of SDM described herein.

[Para 35] Because normally functioning cells are not in need of repair, HSP stimulation in normal cells would tend to have no notable clinical effect. The “patho-selectivity” of near infrared laser effects, such as SDM, affecting sick cells but not affecting normal ones, on various cell types is consistent with clinical observations of SDM. SDM has been reported to have a clinically broad therapeutic range, unique among retinal laser modalities, consistent with American National Standards Institute “Maximum Permissible Exposure” predictions. While SDM may cause direct photothermal effects such as entropic protein unfolding and disaggregation, SDM appears optimized for clinically safe and effective stimulation of HSP-mediated repair.

[Para 36] As noted above, while SDM stimulation of HSPs is non-specific with regard to the disease process, the result of HSP mediated repair is by its nature specific to the state of the dysfunction. HSPs tend to fix what is wrong, whatever that might be. Thus, the observed effectiveness of SDM in retinal conditions as widely disparate as BRVO, DME, PDR, CSR, age-related and genetic retinopathies, and drug-tolerant NAMD. Conceptually, this facility can be considered a sort of “Reset to Default” mode of SDM action. For the wide range of disorders in which cellular function is critical, SDM normalizes cellular function by triggering a “reset” (to the “factory default settings”) via HSP-mediated cellular repair.

[Para 37] The inventors have found that SDM treatment of patients suffering from age-related macular degeneration (AMD) can slow the progress or even stop the progression of AMD. Most of the patients have seen significant

improvement in dynamic functional logMAR mesopic visual acuity and mesopic contrast visual acuity after the SDM treatment. It is believed that SDM works by targeting, preserving, and “normalizing” (moving toward normal) function of the retinal pigment epithelium (RPE).

[Para 38] SDM has also been shown to stop or reverse the manifestations of the diabetic retinopathy disease state without treatment-associated damage or adverse effects, despite the persistence of systemic diabetes mellitus. On this basis it is hypothesized that SDM might work by inducing a return to more normal cell function and cytokine expression in diabetes-affected RPE cells, analogous to hitting the “reset” button of an electronic device to restore the factory default settings. Based on the above information and studies, SDM treatment may directly affect cytokine expression via heat shock protein (HSP) activation in the targeted tissue.

[Para 39] As heat shock proteins play a role in responding to a large number of abnormal conditions in body tissue other than eye tissue, it is believed that similar systems and methodologies can be advantageously used in treating such abnormal conditions, infections, etc. As such, the present invention is directed to the controlled application of ultrasound or electromagnetic radiation to treat abnormal conditions including inflammations, autoimmune conditions, and cancers that are accessible by means of fiber optics of endoscopes or surface probes as well as focused electromagnetic/sound waves. For example, cancers on the surface of the prostate that have the largest threat of metastasizing can be accessed by means of fiber optics in a proctoscope.

Colon tumors can be accessed by an optical fiber system, like those used in colonoscopy.

[Para 40] As indicated above, subthreshold diode micropulse laser (SDM) photostimulation has been effective in stimulating direct repair of slightly misfolded proteins in eye tissue. Besides HSP activation, another way this may occur is because the spikes in temperature caused by the micropulses in the form of a thermal time-course allows diffusion of water inside proteins, and this allows breakage of the peptide-peptide hydrogen bonds that prevent the protein from returning to its native state. The diffusion of water into proteins results in an increase in the number of restraining hydrogen bonds by a factor on the order of a thousand. Thus, it is believed that this process could be applied to other diseases advantageously as well.

[Para 41] Photostimulation, in accordance with the present invention, can be effectively transmitted to an internal surface area or tissue of the body utilizing an endoscope, such as a bronchoscope, proctoscope, colonoscope or the like. Each of these consist essentially of a flexible tube that itself contains one or more internal tubes. Typically, one of the internal tubes comprises a light pipe or multi-mode optical fiber which conducts light down the scope to illuminate the region of interest and enable the doctor to see what is at the illuminated end. Another internal tube could consist of wires that carry an electrical current to enable the doctor to cauterize the illuminated tissue. Yet another internal tube might consist of a biopsy tool that would enable the doctor to snip off and hold on to any of the illuminated tissue.

[Para 42] In the present invention, one of these internal tubes is used as an electromagnetic radiation pipe, such as a multi-mode optical fiber, to transmit the SDM or other electromagnetic radiation pulses that are fed into the scope at the end that the doctor holds. With reference now to FIG. 1, a light generating unit 10, such as a laser having a desired wavelength and/or frequency is used to generate electromagnetic radiation, such as laser light, in a controlled, pulsed manner to be delivered through a light tube or pipe 12 to a distal end of the scope 14, illustrated in FIG. 2, which is inserted into the body and the laser light or other radiation 16 delivered to the target tissue 18 to be treated.

[Para 43] With reference now to FIG. 3, a schematic diagram is shown of a system for generating electromagnetic energy radiation, such as laser light, including SDM. The system, generally referred to by the reference number 20, includes a laser console 22, such as for example the 810nm near infrared micropulsed diode laser in the preferred embodiment. The laser generates a laser light beam which is passed through optics, such as an optical lens or mask, or a plurality of optical lenses and/or masks 24 as needed. The laser projector optics 24 pass the shaped light beam to a delivery device 26, such as an endoscope, for projecting the laser beam light onto the target tissue of the patient. It will be understood that the box labeled 26 can represent both the laser beam projector or delivery device as well as a viewing system/camera, such as an endoscope, or comprise two different components in use. The viewing system/camera 26 provides feedback to a display monitor 28, which may also include the necessary computerized hardware, data input and

controls, etc. for manipulating the laser 22, the optics 24, and/or the projection/viewing components 26.

[Para 44] With reference now to FIG. 4, in one embodiment, the laser light beam 30 may be passed through a collimator lens 32 and then through a mask 34. In a particularly preferred embodiment, the mask 34 comprises a diffraction grating. The mask/diffraction grating 34 produces a geometric object, or more typically a geometric pattern of simultaneously produced multiple laser spots or other geometric objects. This is represented by the multiple laser light beams labeled with reference number 36. Alternatively, the multiple laser spots may be generated by a plurality of fiber optic waveguides. Either method of generating laser spots allows for the creation of a very large number of laser spots simultaneously over a very wide treatment field. In fact, a very high number of laser spots, perhaps numbering in the hundreds even thousands or more could be simultaneously generated to cover a given area of the target tissue, or possibly even the entirety of the target tissue. A wide array of simultaneously applied small separated laser spot applications may be desirable as such avoids certain disadvantages and treatment risks known to be associated with large laser spot applications.

[Para 45] Using optical features with a feature size on par with the wavelength of the laser employed, for example using a diffraction grating, it is possible to take advantage of quantum mechanical effects which permits simultaneous application of a very large number of laser spots for a very large target area. The individual spots produced by such diffraction gratings are all

of a similar optical geometry to the input beam, with minimal power variation for each spot. The result is a plurality of laser spots with adequate irradiance to produce harmless yet effective treatment application, simultaneously over a large target area. The present invention also contemplates the use of other geometric objects and patterns generated by other diffractive optical elements.

[Para 46] The laser light passing through the mask 34 diffracts, producing a periodic pattern a distance away from the mask 34, shown by the laser beams labeled 36 in FIG. 4. The single laser beam 30 has thus been formed into hundreds or even thousands of individual laser beams 36 so as to create the desired pattern of spots or other geometric objects. These laser beams 36 may be passed through additional lenses, collimators, etc. 38 and 40 in order to convey the laser beams and form the desired pattern. Such additional lenses, collimators, etc. 38 and 40 can further transform and redirect the laser beams 36 as needed.

[Para 47] Arbitrary patterns can be constructed by controlling the shape, spacing and pattern of the optical mask 34. The pattern and exposure spots can be created and modified arbitrarily as desired according to application requirements by experts in the field of optical engineering. Photolithographic techniques, especially those developed in the field of semiconductor manufacturing, can be used to create the simultaneous geometric pattern of spots or other objects.

[Para 48] FIG. 5 illustrates diagrammatically a system which couples multiple light sources into the pattern-generating optical subassembly described above.

Specifically, this system 20' is similar to the system 20 described in FIG. 3 above. The primary differences between the alternate system 20' and the earlier described system 20 is the inclusion of a plurality of laser consoles, the outputs of which are each fed into a fiber coupler 42. The fiber coupler produces a single output that is passed into the laser projector optics 24 as described in the earlier system. The coupling of the plurality of laser consoles 22 into a single optical fiber is achieved with a fiber coupler 42 as is known in the art. Other known mechanisms for combining multiple light sources are available and may be used to replace the fiber coupler described herein.

[Para 49] In this system 20' the multiple light sources 22 follow a similar path as described in the earlier system 20, i.e., collimated, diffracted, recollimated, and directed to the projector device and/or tissue. In this alternate system 20' the diffractive element must function differently than described earlier depending upon the wavelength of light passing through, which results in a slightly varying pattern. The variation is linear with the wavelength of the light source being diffracted. In general, the difference in the diffraction angles is small enough that the different, overlapping patterns may be directed along the same optical path through the projector device 26 to the tissue for treatment.

[Para 50] Since the resulting pattern will vary slightly for each wavelength, a sequential offsetting to achieve complete coverage will be different for each wavelength. This sequential offsetting can be accomplished in two modes. In the first mode, all wavelengths of light are applied simultaneously without

identical coverage. An offsetting steering pattern to achieve complete coverage for one of the multiple wavelengths is used. Thus, while the light of the selected wavelength achieves complete coverage of the tissue, the application of the other wavelengths achieves either incomplete or overlapping coverage of the tissue. The second mode sequentially applies each light source of a varying wavelength with the proper steering pattern to achieve complete coverage of the tissue for that particular wavelength. This mode excludes the possibility of simultaneous treatment using multiple wavelengths, but allows the optical method to achieve identical coverage for each wavelength. This avoids either incomplete or overlapping coverage for any of the optical wavelengths.

[Para 51] These modes may also be mixed and matched. For example, two wavelengths may be applied simultaneously with one wavelength achieving complete coverage and the other achieving incomplete or overlapping coverage, followed by a third wavelength applied sequentially and achieving complete coverage.

[Para 52] FIG. 6 illustrates diagrammatically yet another alternate embodiment of the inventive system 20". This system 20" is configured generally the same as the system 20 depicted in FIG. 3. The main difference resides in the inclusion of multiple pattern-generating subassembly channels tuned to a specific wavelength of the light source. Multiple laser consoles 22 are arranged in parallel with each one leading directly into its own laser projector optics 24. The laser projector optics of each channel 44a, 44b, 44c comprise a collimator 32, mask or diffraction grating 34 and recollimators 38,

40 as described in connection with FIG. 4 above – the entire set of optics tuned for the specific wavelength generated by the corresponding laser console 22. The output from each set of optics 24 is then directed to a beam splitter 46 for combination with the other wavelengths. It is known by those skilled in the art that a beam splitter used in reverse can be used to combine multiple beams of light into a single output.

[Para 53] The combined channel output from the final beam splitter 46c is then directed through the projector device 26.

[Para 54] In this system 20" the optical elements for each channel are tuned to produce the exact specified pattern for that channel's wavelength. Consequently, when all channels are combined and properly aligned a single steering pattern may be used to achieve complete coverage of the tissue for all wavelengths.

[Para 55] The system 20" may use as many channels 44a, 44b, 44c, etc. and beam splitters 46a, 46b, 46c, etc. as there are wavelengths of light being used in the treatment.

[Para 56] Implementation of the system 20" may take advantage of different symmetries to reduce the number of alignment constraints. For example, the proposed grid patterns are periodic in two dimensions and steered in two dimensions to achieve complete coverage. As a result, if the patterns for each channel are identical as specified, the actual pattern of each channel would not need to be aligned for the same steering pattern to achieve complete coverage

for all wavelengths. Each channel would only need to be aligned optically to achieve an efficient combination.

[Para 57] In system 20", each channel begins with a light source 22, which could be from an optical fiber as in other embodiments of the pattern-generating subassembly. This light source 22 is directed to the optical assembly 24 for collimation, diffraction, recollimation and directed into the beam splitter which combines the channel with the main output.

[Para 58] It will be understood that the laser light generating systems illustrated in FIGS. 3-6 are exemplary. Other devices and systems can be utilized to generate a source of SDM laser light which can be operably passed through to a projector device, typically in the form of an endoscope having a light pipe or the like. Other forms of electromagnetic radiation may also be generated and used, including ultraviolet waves, microwaves, other radiofrequency waves, and laser light at predetermined wavelengths. Moreover, ultrasound waves may also be generated and used to create a thermal time-course temperature spike in the target tissue sufficient to activate or produce heat shock proteins in the cells of the target tissue without damaging the target tissue itself. In order to do so, typically, a pulsed source of ultrasound or electromagnetic radiation energy is provided and applied to the target tissue in a manner which raises the target tissue temperature, such as at least 10°C, transiently while only 1°C or less for the long term, such as over several minutes, such as two or more minutes.

[Para 59] For deep tissue that is not near an internal orifice, a light pipe is not an effective means of delivering the pulsed energy. In that case, pulsed low frequency electromagnetic energy or preferably pulsed ultrasound can be used to cause a series of temperature spikes in the target tissue.

[Para 60] Thus, in accordance with the present invention, a source of pulsed ultrasound or electromagnetic radiation is applied to the target tissue in order to stimulate HSP production or activation and to facilitate protein repair in the living animal tissue. In general, Electromagnetic radiation may be ultraviolet waves, microwaves, other radiofrequency waves, laser light at predetermined wavelengths, etc. On the other hand, if electromagnetic energy is to be used for deep tissue targets away from natural orifices, absorption lengths restrict the wavelengths to those of microwaves or radiofrequency waves, depending on the depth of the target tissue. However, as explained later, ultrasound is to be preferred to long wavelength electromagnetic radiation for deep tissue targets away from natural orifices.

[Para 61] The ultrasound or electromagnetic radiation is pulsed so as to create a thermal time-course in the tissue that stimulates HSP production or activation and facilitates protein repair without causing damage to the cells and tissue being treated. The area and/or volume of the treated tissue is also controlled and minimized so that the temperature spikes are on the order of several degrees, e.g. approximately 10°C, while maintaining the long-term rise in temperature to be less than the FDA mandated limit of 1°C. It has been found that if too large of an area or volume of tissue is treated, the increased

temperature of the tissue cannot be diffused sufficiently quickly enough to meet the FDA requirements. However, limiting the area and/or volume of the treated tissue as well as creating a pulsed source of energy accomplishes the goals of the present invention of stimulating HSP activation or production by heating or otherwise stressing the cells and tissue, while allowing the treated cells and tissues to dissipate any excess heat generated to within acceptable limits.

[Para 62] It is believed that stimulating HSP production in accordance with the present invention can be effectively utilized in treating a wide array of tissue abnormalities, ailments, and even infections. For example, the viruses that cause colds primarily affect a small part of the respiratory epithelium in the nasal passages and nasopharynx. Similar to the retina, the respiratory epithelium is a thin and clear tissue. With reference to FIG. 7, a cross-sectional view of a human head 48 is shown with an endoscope 14 inserted into the nasal cavity 50 and energy 16, such as laser light or the like, being directed to tissue 18 to be treated within the nasal cavity 50. The tissue 18 to be treated could be within the nasal cavity 50, including the nasal passages, and nasopharynx.

[Para 63] To assure absorption of the laser energy, or other energy source, the wavelength can be adjusted to an infrared (IR) absorption peak of water, or an adjuvant dye can be used to serve as a photosensitizer. In such a case, treatment would then consist of drinking, or topically applying, the adjuvant, waiting a few minutes for the adjuvant to permeate the surface tissue, and then administering the laser light or other energy source 16 to the target tissue 18

for a few seconds, such as via optical fibers in an endoscope 14, as illustrated in FIG. 7. To provide comfort of the patient, the endoscope 14 could be inserted after application of a topical anesthetic. If necessary, the procedure could be repeated periodically, such as in a day or so.

[Para 64] As discussed above, the treatment would stimulate the activation or production of heat shock proteins and facilitate protein repair without damaging the cells and tissues being treated. As discussed above, certain heat shock proteins have been found to play an important role in the immune response as well as the well-being of the targeted cells and tissue. The source of energy could be monochromatic laser light, such as 810nm wavelength laser light, administered in a manner similar to that described in the above-referenced patent applications, but administered through an endoscope or the like, as illustrated in FIG. 7. The adjuvant dye would be selected so as to increase the laser light absorption. While this comprises a particularly preferred method and embodiment of performing the invention, it will be appreciated that other types of energy and delivery means could be used to achieve the same objectives in accordance with the present invention.

[Para 65] With reference now to FIG. 8, a similar situation exists for the flu virus, where the primary target is the epithelium of the upper respiratory tree, in segments that have diameters greater than about 3.3mm, namely, the upper six generations of the upper respiratory tree. A thin layer of mucous separates the targeted epithelial cells from the airway lumen, and it is in this layer that the antigen-antibody interactions occur that result in inactivation of the virus.

[Para 66] With continuing reference to FIG. 8, the flexible light tube 12 of a bronchoscope 14 is inserted through the individual's mouth 52 through the throat and trachea 54 and into a bronchus 56 of the respiratory tree. There the laser light or other energy source 16 is administered and delivered to the tissue in this area of the uppermost segments to treat the tissue and area in the same manner described above with respect to FIG. 7. It is contemplated that a wavelength of laser or other energy would be selected so as to match an IR absorption peak of the water resident in the mucous to heat the tissue and stimulate HSP activation or production and facilitate protein repair, with its attendant benefits.

[Para 67] With reference now to FIG. 9, a colonoscope 14 could have flexible optical tube 12 thereof inserted into the anus and rectum 58 and into either the large intestine 60 or small intestine 62 so as to deliver the selected laser light or other energy source 16 to the area and tissue to be treated, as illustrated. This could be used to assist in treating colon cancer as well as other gastrointestinal issues.

[Para 68] Typically, the procedure could be performed similar to a colonoscopy in that the bowel would be cleared of all stool, and the patient would lie on his/her side and the physician would insert the long, thin light tube portion 12 of the colonoscope 14 into the rectum and move it into the area of the colon, large intestine 60 or small intestine 64 to the area to be treated. The physician could view through a monitor the pathway of the inserted flexible member 12 and even view the tissue at the tip of the

colonoscope 14 within the intestine, so as to view the area to be treated. Using one of the other fiber optic or light tubes, the tip 64 of the scope would be directed to the tissue to be treated and the source of laser light or other radiation 16 would be delivered through one of the light tubes of the colonoscope 14 to treat the area of tissue to be treated, as described above, in order to stimulate HSP activation or production in that tissue 18.

[Para 69] With reference now to FIG. 10, another example in which the present invention can be advantageously used is what is frequently referred to as "leaky gut" syndrome, a condition of the gastrointestinal (GI) tract marked by inflammation and other metabolic dysfunction. Since the GI tract is susceptible to metabolic dysfunction similar to the retina, it is anticipated that it will respond well to the treatment of the present invention. This could be done by means of subthreshold, diode micropulse laser (SDM) treatment, as discussed above, or by other energy sources and means as discussed herein and known in the art.

[Para 70] With continuing reference to FIG. 10, the flexible light tube 12 of an endoscope or the like is inserted through the patient's mouth 52 through the throat and trachea area 54 and into the stomach 66, where the tip or end 64 thereof is directed towards the tissue 18 to be treated, and the laser light or other energy source 16 is directed to the tissue 18. It will be appreciated by those skilled in the art that a colonoscope could also be used and inserted through the rectum 58 and into the stomach 66 or any tissue between the stomach and the rectum.

[Para 71] If necessary, a chromophore pigment could be delivered to the GI tissue orally to enable absorption of the radiation. If, for instance, unfocused 810nm radiation from a laser diode or LED were to be used, the pigment would have an absorption peak at or near 810nm. Alternatively, the wavelength of the energy source could be adjusted to a slightly longer wavelength at an absorption peak of water, so that no externally applied chromophore would be required.

[Para 72] It is also contemplated by the present invention that a capsule endoscope 68, such as that illustrated in FIG. 11, could be used to administer the radiation and energy source in accordance with the present invention. Such capsules are relatively small in size, such as approximately one inch in length, so as to be swallowed by the patient. As the capsule or pill 68 is swallowed and enters into the stomach and passes through the GI tract, when at the appropriate location, the capsule or pill 68 could receive power and signals, such as via antenna 70, so as to activate the source of energy 72, such as a laser diode and related circuitry, with an appropriate lens 74 focusing the generated laser light or radiation through a radiation-transparent cover 76 and onto the tissue to be treated. It will be understood that the location of the capsule endoscope 68 could be determined by a variety of means such as external imaging, signal tracking, or even by means of a miniature camera with lights through which the doctor would view images of the GI tract through which the pill or capsule 68 was passing through at the time. The capsule or pill 68 could be supplied with its own power source, such as by virtue of a

battery, or could be powered externally via an antenna, such that the laser diode 72 or other energy generating source create the desired wavelength and pulsed energy source to treat the tissue and area to be treated.

[Para 73] As in the treatment of the retina in previous applications, the radiation would be pulsed to take advantage of the micropulse temperature spikes and associated safety, and the power could be adjusted so that the treatment would be completely harmless to the tissue. This could involve adjusting the peak power, pulse times, and repetition rate to give spike temperature rises on the order of 10°C, while maintaining the long term rise in temperature to be less than the FDA mandated limit of 1°C. If the pill form 68 of delivery is used, the device could be powered by a small rechargeable battery or over wireless inductive excitation or the like. The heated/stressed tissue would stimulate activation or production of HSP and facilitate protein repair, and the attendant benefits thereof.

[Para 74] From the foregoing examples, the technique of the present invention is limited to the treatment of conditions at near body surfaces or at internal surfaces easily accessible by means of fiber optics or other optical delivery means. The reason that the application of SDM to activate HSP activity is limited to near surface or optically accessible regions of the body is that the absorption length of IR or visible radiation in the body is very short. However, there are conditions deeper within tissue or the body which could benefit from the present invention. Thus, the present invention contemplates the use of ultrasound and/or radio frequency (RF) and even shorter wavelength

electromagnetic (EM) radiation which have relatively long absorption lengths in body tissue. As will be more fully described below, the use of pulsed ultrasound is preferable to RF electromagnetic radiation to activate remedial HSP activity in abnormal tissue that is inaccessible to surface SDM or the like. Pulsed ultrasound sources can also be used for abnormalities at or near surfaces as well.

[Para 75] With reference now to FIG. 12, with ultrasound, a specific region deep in the body can be specifically targeted by using one or more beams that are each focused on the target site. The pulsating heating will then be largely only in the targeted region where the beams are focused and overlap.

[Para 76] As illustrated in FIG. 12, an ultrasound transducer 78 or the like generates a plurality of ultrasound beams 80 which are coupled to the skin via an acoustic-impedance-matching gel, and penetrate through the skin 82 and through undamaged tissue in front of the focus of the beams 80 to a target organ 84, such as the illustrated liver, and specifically to a target tissue 86 to be treated where the ultrasound beams 80 are focused. As mentioned above, the pulsating heating will then only be at the targeted, focused region 86 where the focused beams 80 overlap. The tissue in front of and behind the focused region 86 will not be heated or affected appreciably.

[Para 77] Examples of parameters giving a desired HSP activation Arrhenius integral greater than 1 and damage Arrhenius integral less than 1 is a total ultrasound power between 5.8-17 watts, a pulse duration of 0.5 seconds, an interval between pulses of 5 seconds, with total number of pulses 10 within the

total pulse stream time of 50 seconds. The target treatment volume would be approximately 1mm on a side. Larger treatment volumes could be treatable by an ultrasound system similar to the laser diffracted optical system (described in paragraph 45), by applying ultrasound in multiple simultaneously applied adjacent but separated and spaced columns. As mentioned above, the multiple focused ultrasound beams converge on a very small treatment target within the body, the convergence allowing for a minimal heating except at the overlapping beams at the target. This area would be heated and stimulate the activation of HSPs and facilitate protein repair by transient high temperature spikes. However, given the pulsating aspect of the invention as well as the relatively small area being treated at any given time, the treatment is in compliance with FDA/FCC requirements for long term (minutes) average temperature rise <1K. An important distinction of the invention from existing therapeutic heating treatments for pain and muscle strain is that there are no high T spikes in existing techniques, and these are required for efficiently activating HSPs and facilitating protein repair to provide healing at the cellular level.

[Para 78] The pulse train mode of energy delivery has a distinct advantage over a single pulse or gradual mode of energy delivery, as far as the activation of remedial HSPs and the facilitation of protein repair is concerned. There are two considerations that enter into this advantage:

[Para 79] First, a big advantage for HSP activation and protein repair in an SDM energy delivery mode comes from producing a spike temperature of the order of 10°C. This large rise in temperature has a big impact on the Arrhenius

integrals that describe quantitatively the number of HSPs that are activated and the rate of water diffusion into the proteins that facilitates protein repair. This is because the temperature enters into an exponential that has a big amplification effect.

[Para 80] It is important that the temperature rise not remain at the high value (10+ degrees) for long, because then it would violate the FDA and FCC requirements that over periods of minutes the average temperature rise must be less than 1°C.

[Para 81] An SDM mode of energy delivery uniquely satisfies both of these foregoing considerations by judicious choice of the power, pulse time, pulse interval, and the volume of the target region to be treated. The volume of the treatment region enters because the temperature must decay from its high value of the order of 10°C fairly rapidly in order for the long term average temperature rise not to exceed the long term FDA/FCC limit of 1°C.

[Para 82] For a region of linear dimension L , the time that it takes the peak temperature to e-fold in tissue is roughly $L^2/16D$, where $D = 0.00143 \text{ cm}^2/\text{sec}$ is the typical heat diffusion coefficient. For example, if $L = 1 \text{ mm}$, the decay time is roughly 0.4 sec. Accordingly, for a region 1 mm on a side, a train consisting of 10 pulses each of duration 0.5 seconds, with an interval between pulses of 5 second can achieve the desired momentary high rise in temperature while still not exceeding an average long term temperature rise of 1°C. This is demonstrated further below.

[Para 83] The limitation of heated volume is the reason why RF electromagnetic radiation is not as good of a choice for SDM-type treatment of regions deep with the body. The long skin depths (penetration distances) and Ohmic heating all along the skin depth results in a large heated volume whose thermal inertia does not allow both the attainment of a high spike temperature that activates HSPs and facilitates protein repair, and the rapid temperature decay that satisfies the long term FDA and FCC limit on average temperature rise.

[Para 84] Ultrasound has already been used to therapeutically heat regions of the body to ease pain and muscle strain. However, the heating has not followed the SDM-type protocol and does not have the temperature spikes that are responsible for the excitation of HSPs.

[Para 85] Consider, then, a group of focused ultrasound beams that are directed at a target region deep within the body. To simplify the mathematics, suppose that the beams are replaced by a single source with a spherical surface shape that is focused on the center of the sphere. The absorption lengths of ultrasound can be fairly long. Table 1 below shows typical absorption coefficients for ultrasound at 1 MHz. The absorption coefficients are roughly proportional to the frequency.

[Para 86] Table 1. Typical absorption coefficients for 1 MHz ultrasound in body tissue:

Body Tissue	Attenuation Coefficient at 1 MHz (cm ⁻¹)
Water	0.00046

Blood	0.0415
Fat	0.145
Liver	0.115-0.217
Kidney	0.23
Muscle	0.3-0.76
Bone	1.15

[Para 87] Assuming that the geometric variation of the incoming radiation due to the focusing dominates any variation due to attenuation, the intensity of the incoming ultrasound at a distance r from the focus can be written approximately as:

$$I(r) = P/(4\pi r^2) \quad [1]$$

where P denotes the total ultrasound power.

The temperature rise at the end of a short pulse of duration t_p at r is then

$$dT(t_p) = P\alpha t_p / (4\pi C_v r^2) \quad [2]$$

where α is the absorption coefficient and C_v is the specific volume heat capacity. This will be the case until the r is reached at which the heat diffusion length at t_p becomes comparable to r , or the diffraction limit of the focused beam is reached. For smaller r , the temperature rise is essentially independent of r . As an example, suppose the diffraction limit is reached at a radial distance that is smaller than that determined by heat diffusion. Then

$$r_{dif} = (4Dt_p)^{1/2} \quad [3]$$

where D is the heat diffusion coefficient, and for $r < r_{dif}$, the temperature rise at t_p is

$$dT(r_{dif}, t_p) = 3P\alpha/(8\pi C_v D) \quad \text{when } r < r_{dif} \quad [4]$$

Thus, at the end of the pulse, we can write for the temperature rise:

$$dT_p(r) = \{P\alpha t_p/(4\pi C_v)\}[(6/r_{dif}^2)U\{r_{dif}-r\} + (1/r^2)U(r-r_{dif})] \quad [5]$$

On applying the Green's function for the heat diffusion equation,

$$G(r,t) = (4\Omega Dt)^{-3/2} \exp[-r^2/(4Dt)] \quad [6]$$

to this initial temperature distribution, we find that the temperature $dT(t)$ at the focal point $r=0$ at a time t is

$$dT(t) = [dT_o/\{(1/2)+(\pi^{1/2}/6)\}][(1/2)(t_p/t)^{3/2} + (\pi^{1/2}/6)(t_p/t)] \quad [7]$$

with

$$dT_o = 3P\alpha/(8\pi C_v D) \quad [8]$$

[Para 88] A good approximation to eq. [7] is provided by:

$$dT(t) \approx dT_o (t_p/t)^{3/2} \quad [9]$$

as can be seen in Graph 1 below.

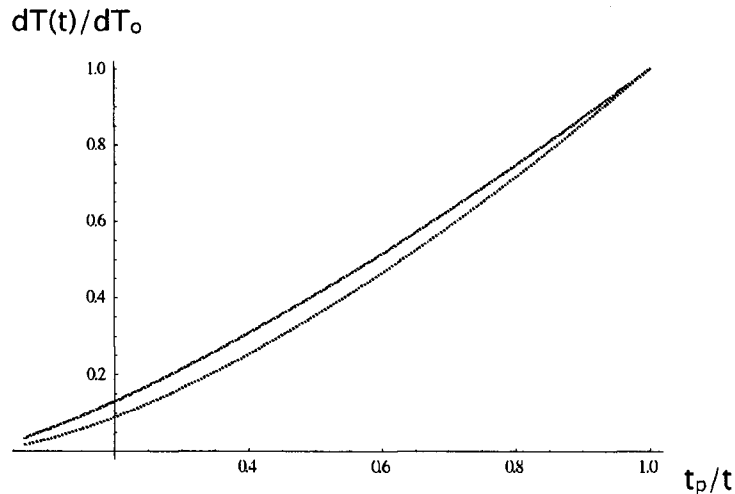

Graph 1. Comparison of eqs. [7] and [9] for $dT(t)/dT_o$ at the target treatment zone. The bottom curve is the approximate expression of eq [9].

The Arrhenius integral for a train of N pulses can now be evaluated with the temperature rise given by eq. [9]. In this expression,

$$dT_N(t) = \sum dT(t-nt_i) \quad [11]$$

where $dT(t-nt_i)$ is the expression of eq. [9] with t replaced by $t-nt_i$ and with t_i designating the interval between pulses.

[Para 89] The Arrhenius integral can be evaluated approximately by dividing the integration interval into the portion where the temperature spikes occur and the portion where the temperature spike is absent. The summation over the temperature spike contribution can be simplified by applying Laplace's end point formula to the integral over the temperature spike. In addition, the integral over the portion when the spikes are absent can be simplified by noting that the non-spike temperature rise very rapidly reaches an asymptotic value, so that a good approximation is obtained by replacing the varying time rise by its asymptotic value. When these approximations are made, eq. [10] becomes:

$$\Omega = AN \left[\left\{ t_p (2k_B T_o^2 / (3EdT_o)) \exp[-(E/k_B)1 / (T_o + dT_o + dT_N(Nt_i))] \right. \right. \\ \left. \left. + \exp[-(E/k_B)1 / (T_o + dT_N(Nt_i))] \right\} \right] \quad [12]$$

where

$$dT_N(Nt_i) \approx 2.5 dT_o (t_p/t_i)^{3/2} \quad [13]$$

(The 2.5 in eq. [13] arises from the summation over n of $(N-n)^{-3/2}$ and is the magnitude of the harmonic number $(N, 3/2)$ for typical N of interest.)

[Para 90] It is interesting to compare this expression with that for SDM applied to the retina. The first term is very similar to that from the spike contribution in the retina case, except that the effective spike interval is

reduced by a factor of 3 for this 3D converging beam case. The second term, involving $dT_N(Nt_i)$ is much smaller than in the retina case. There the background temperature rise was comparable in magnitude to the spike temperature rise. But here in the converging beam case, the background temperature rise is much smaller by the ratio $(t_p/t_i)^{3/2}$. This points up the importance of the spike contribution to the activation or production of HSP's and the facilitation of protein repair, as the background temperature rise which is similar to the rise in a continuous ultrasound heating case is insignificant compared to the spike contribution. At the end of the pulse train, even this low background temperature rise rapidly disappears by heat diffusion.

[Para 91] Graph 2 below shows the magnitude of the logarithm of the Arrhenius integrals for damage and for HSP activation or production as a function of dT_o for a pulse duration $t_p = 0.5$ sec, pulse interval $t_i = 10$ sec, and total number of pulses $N = 10$.

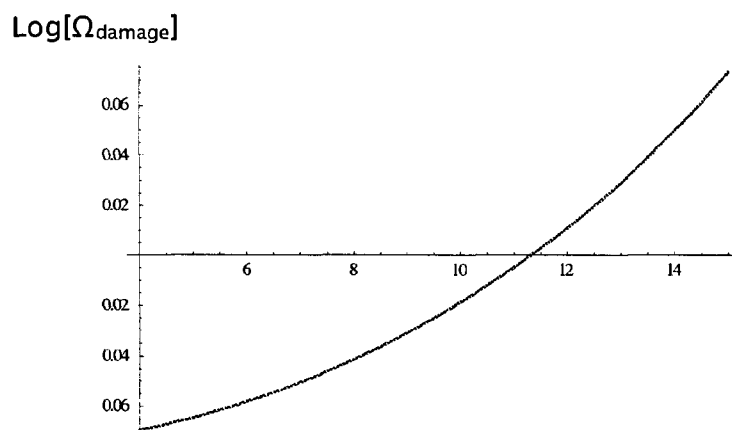

Graph 2a. Damage integral

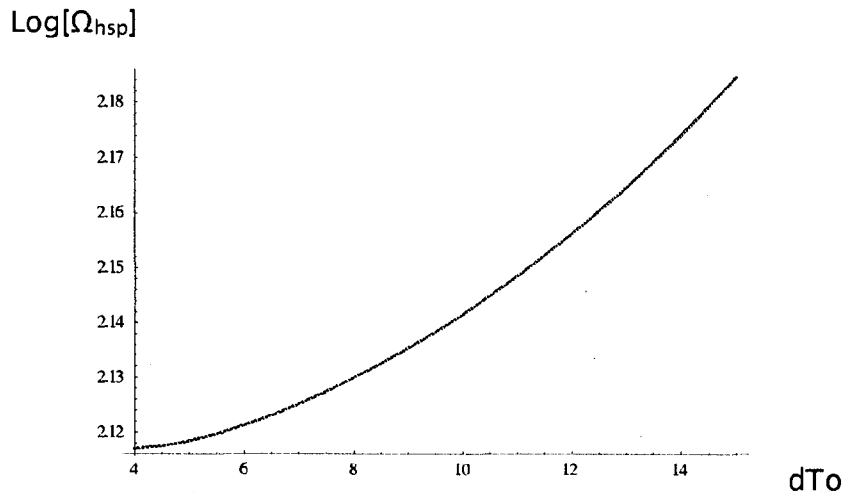

Graph 2b. HSP activation integral

Graph 2. Logarithm of Arrhenius integrals [eq. 12] for damage and for HSP activation as a function of the temperature rise in degrees Kelvin from a single pulse dT_o , for a pulse duration $t_p = 0.5$ sec., pulse interval $t_i = 10$ sec., and a total number of ultrasound pulses $N = 10$. Graph 2a shows the logarithm of the damage integral with the Arrhenius constants $A = 8.71 \times 10^{33} \text{ sec}^{-1}$ and $E = 3.55 \times 10^{-12}$ ergs. Graph 2b shows the logarithm of the HSP activation integral with the Arrhenius constants $A = 1.24 \times 10^{27} \text{ sec}^{-1}$ and $E = 2.66 \times 10^{-12}$ ergs. The graphs show that Ω_{damage} does not exceed 1 until dT_o exceeds 11.3 K, whereas Ω_{hsp} is greater than 1 over the whole interval shown, the desired condition for cellular repair without damage.

[Para 92] Equation [8] shows that when $\alpha = 0.1 \text{ cm}^{-1}$, a dT_o of 11.5 K can be achieved with a total ultrasound power of 5.8 watts. This is easily achievable. If α is increased by a factor of 2 or 3, the resulting power is still easily achievable. The volume of the region where the temperature rise is constant (i.e. the volume corresponding to $r=r_d = (4Dt_p)^{1/2}$) is 0.00064 cc. This corresponds to a cube that is 0.86 mm on a side.

[Para 93] This simple example demonstrates that focused ultrasound should be usable to stimulate reparative HSP's deep in the body with easily attainable equipment:

Total ultrasound power:	5.8 watts - 17 watts
Pulse time	0.5 sec
Pulse interval	5 sec
Total train duration (N=10)	50 sec

To expedite the treatment of larger internal volumes, a SAPRA system can be used.

[Para 94] The present invention contemplates not only the treatment of surface or near surface tissue, such as using the laser light or the like, deep tissue using, for example, focused ultrasound beams or the like, but also treatment of blood diseases, such as sepsis. As indicated above, focused ultrasound treatment could be used both at surface as well as deep body tissue, and could also be applied in this case in treating blood. However, it is also contemplated that the SDM and similar treatment options which are typically limited to surface or near surface treatment of epithelial cells and the like be used in treating blood diseases at areas where the blood is accessible through a relatively thin layer of tissue, such as the earlobe.

[Para 95] With reference now to FIGS. 13 and 14, treatment of blood disorders simply requires the transmission of SDM or other electromagnetic radiation or ultrasound pulses to the earlobe 88, where the SDM or other radiation source of energy could pass through the earlobe tissue and into the

blood which passes through the earlobe. It would be appreciated that this approach could also take place at other areas of the body where the blood flow is relatively high and/or near the tissue surface, such as fingertips, inside of the mouth or throat, etc.

[Para 96] With reference now to FIGS. 13 and 14, an earlobe 88 is shown adjacent to a clamp device 90 configured to transmit SDM radiation or the like. This could be, for example, by means of one or more laser diodes 92 which would transmit the desired frequency at the desired pulse and pulse train to the earlobe 88. Power could be provided, for example, by means of a lamp drive 94. Alternatively, the lamp drive 94 could be the actual source of laser light, which would be transmitted through the appropriate optics and electronics to the earlobe 88. The clamp device 90 would merely be used to clamp onto the patient's earlobe and cause that the radiation be constrained to the patient's earlobe 88. This may be by means of mirrors, reflectors, diffusers, etc. This could be controlled by a control computer 96, which would be operated by a keyboard 98 or the like. The system may also include a display and speakers 100, if needed, for example if the procedure were to be performed by an operator at a distance from the patient.

[Para 97] The proposed treatment with a train of electromagnetic or ultrasound pulses has two major advantages over earlier treatments that incorporate a single short or sustained (long) pulse. First, the short (preferably subsecond) individual pulses in the train activate cellular reset mechanisms like HSP activation with larger reaction rate constants than those operating at longer

(minute or hour) time scales. Secondly, the repeated pulses in the treatment provide large thermal spikes (on the order of 10,000) that allow the cell's repair system to more rapidly surmount the activation energy barrier that separates a dysfunctional cellular state from the desired functional state. The net result is a "lowered therapeutic threshold" in the sense that a lower applied average power and total applied energy can be used to achieve the desired treatment goal.

[Para 98] Although several embodiments have been described in detail for purposes of illustration, various modifications may be made without departing from the scope and spirit of the invention. Accordingly, the invention is not to be limited, except as by the appended claims.

What is claimed is:

1. Use of a source of electromagnetic energy comprising a laser light for causing retinal tissue of an eye unresponsive to medication to become responsive to medication after recovering from exposure to said laser light, wherein the laser light is for application to the retinal tissue without damaging said tissue, the laser light has a wavelength of between 530nm to 1300nm, a duty cycle of less than 10%, and a pulse length of 500 milliseconds or less.
2. The use of claim 1, wherein the use comprises use of a dilating material for dilation of a pupil of the eye containing the retinal tissue.
3. The use of claim 1, wherein the use comprises application of topical proparacaine to a cornea of the eye.
4. The use of claim 1, wherein the use comprises application of a macular contact lens and viscoelastic fluid to the eye.
5. The use of claim 4, wherein the macular contact lens has a magnification factor of 1.05x.
6. The use of claim 1, wherein the laser light is for application to the entire retina.
7. The use of any one of claims 1-6, wherein the laser light comprises a subthreshold diode micropulse laser beam.
8. The use of claim 7, wherein the subthreshold diode micropulse laser beam is for application to between 400 and 1200 spots in a 300 micron treatment area of the retina.
9. The use of claim 7, wherein the subthreshold diode micropulse laser beam has a wavelength between 750 nm-1300 nm at 2.0 Watts.
10. The use of claim 9, wherein the wavelength of the subthreshold micropulse laser beam is approximately 810 nm.

11. The use of claim 7, wherein the subthreshold diode micropulse laser beam has a 0.2 second exposure duration.

12. The use of claim 11, wherein the duty cycle of the micropulse laser beam is approximately 5%.

13. The use of claim 7, wherein the subthreshold diode micropulse laser beam has a pulse length of 50 microseconds or less.

14. The use of claim 13, wherein the pulse length is 20 microseconds.

15. The use of claim 1, wherein the retinal tissue recovers from the laser light exposure for a period of time of up to one month.

16. The use of claim 1 wherein the laser light is diffracted to create a plurality of laser beams for simultaneous application to the retina.

17. The use of claim 16, wherein the laser light beams form a periodic pattern of a multitude of individual treatment spots on the retina.

18. The use of claim 17, wherein the laser light beams are sequentially offset so as to completely cover the retinal tissue.

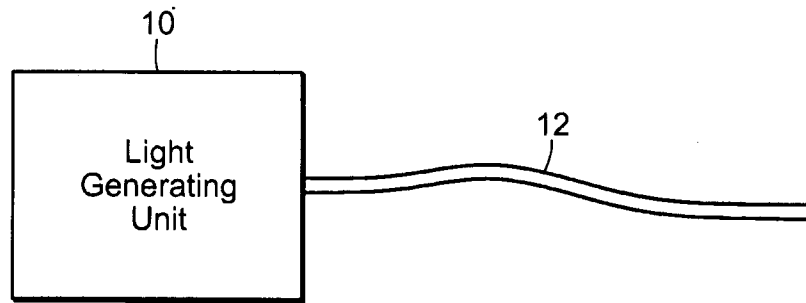

FIG. 1

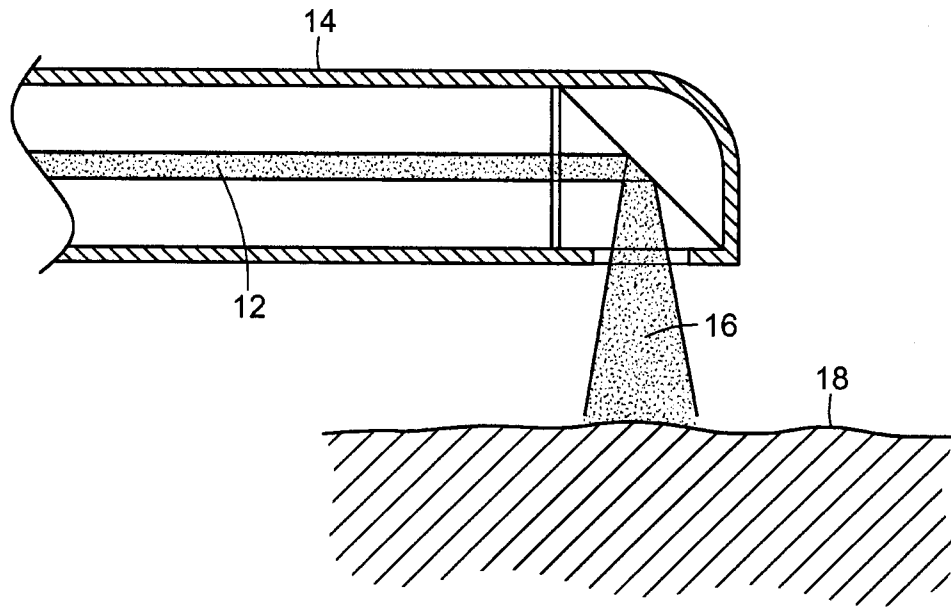

FIG. 2

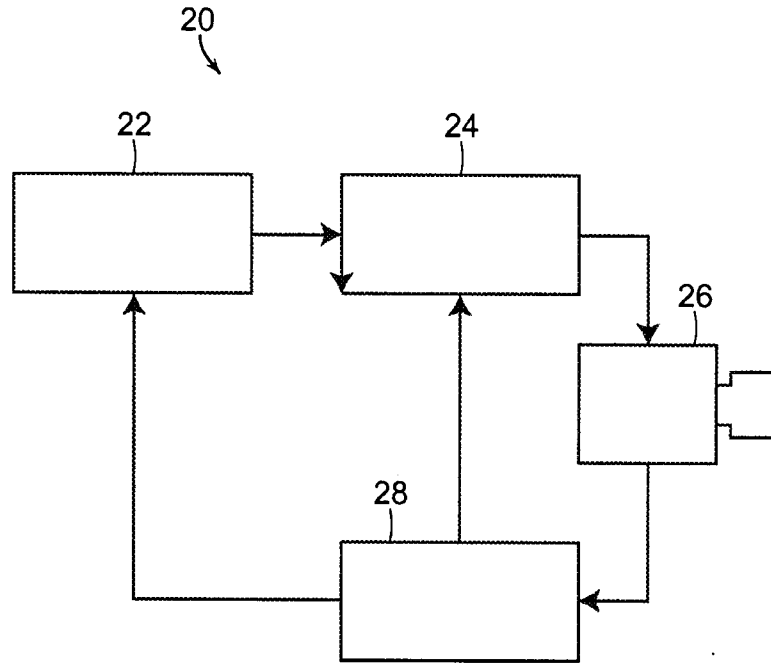

FIG. 3

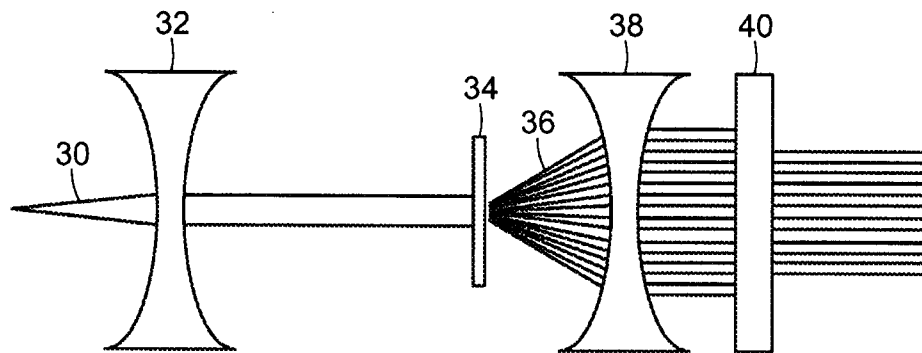

FIG. 4

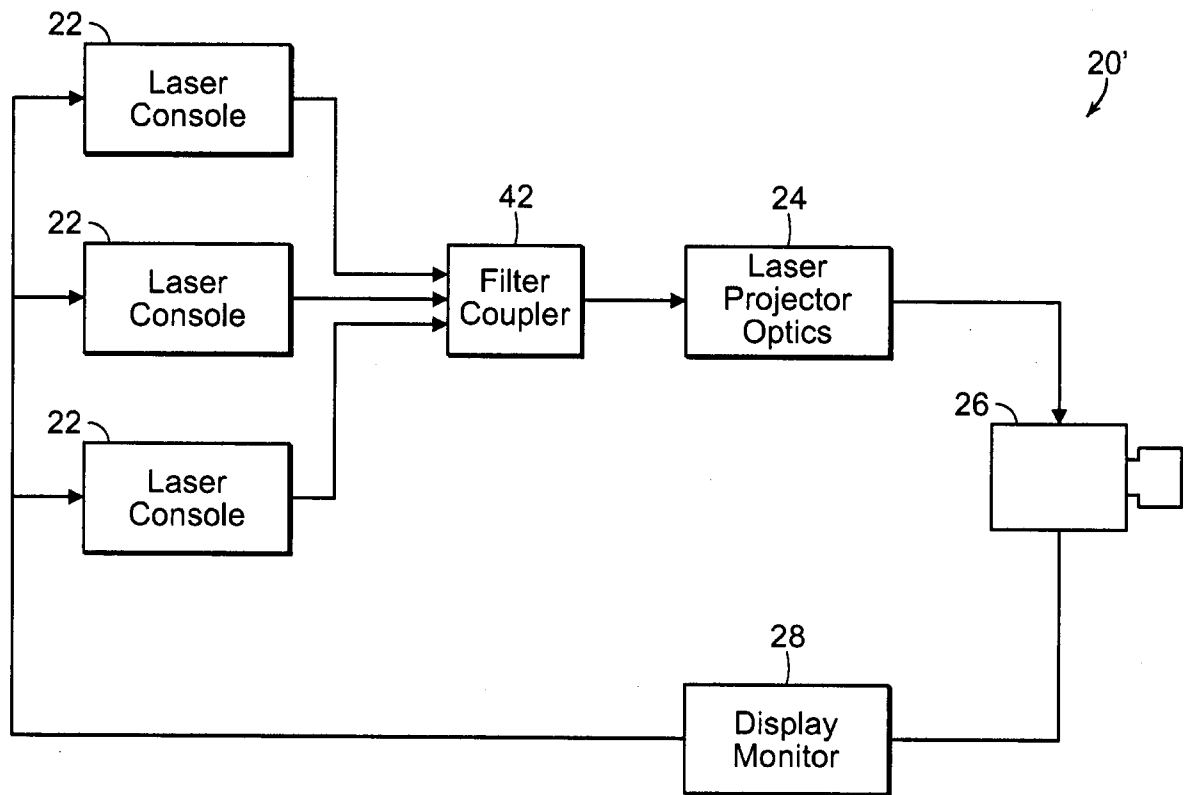

FIG. 5

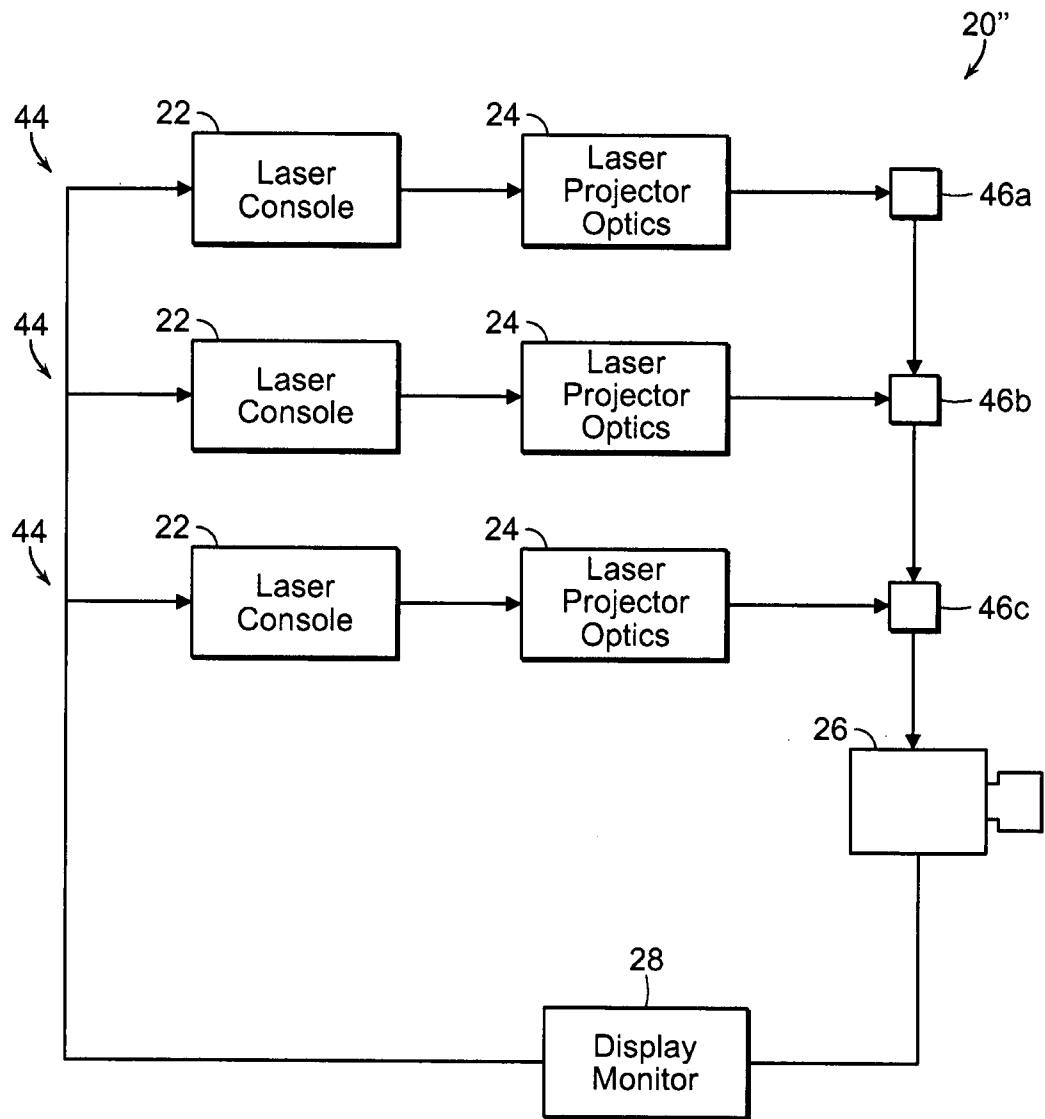

FIG. 6

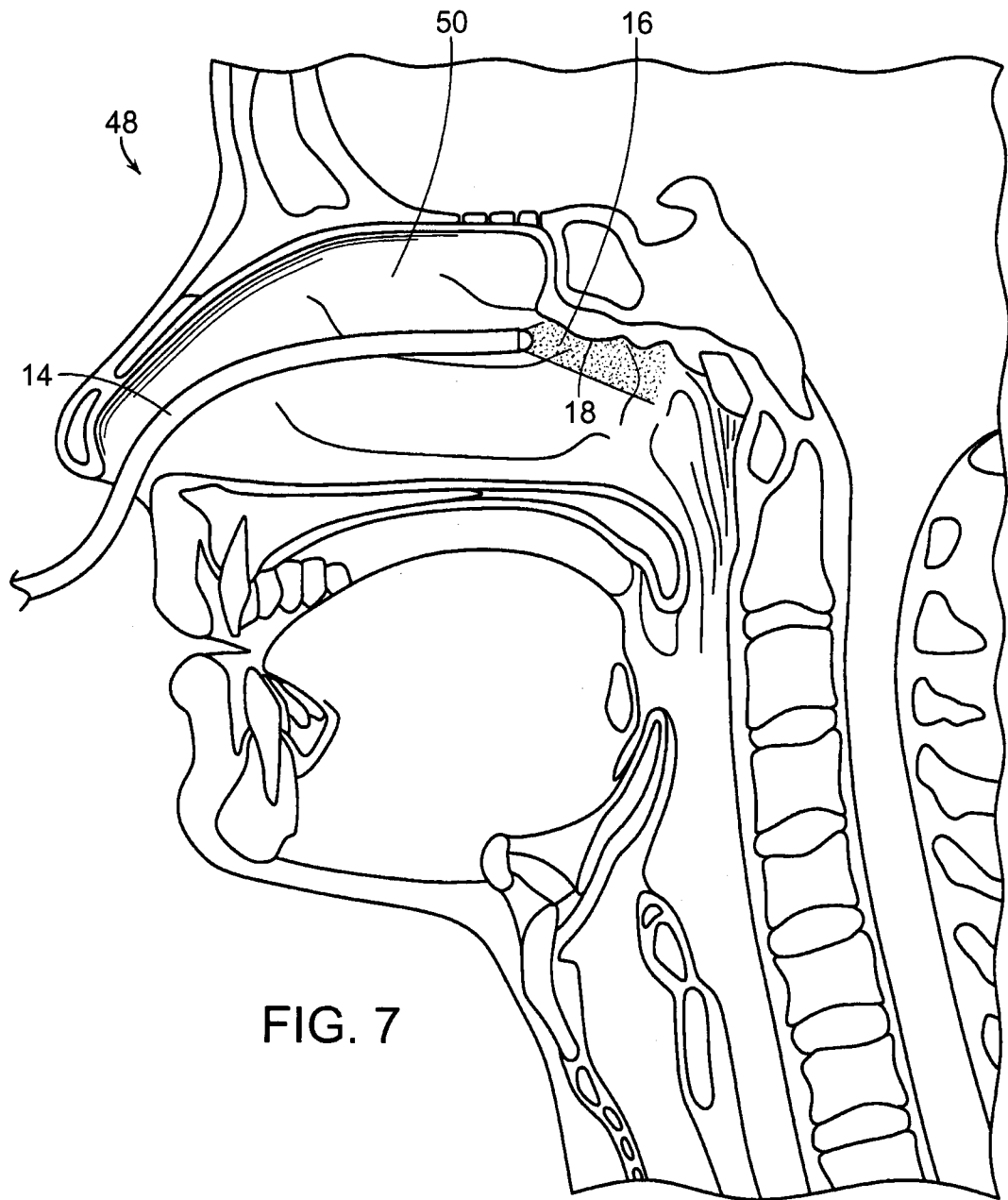

FIG. 7

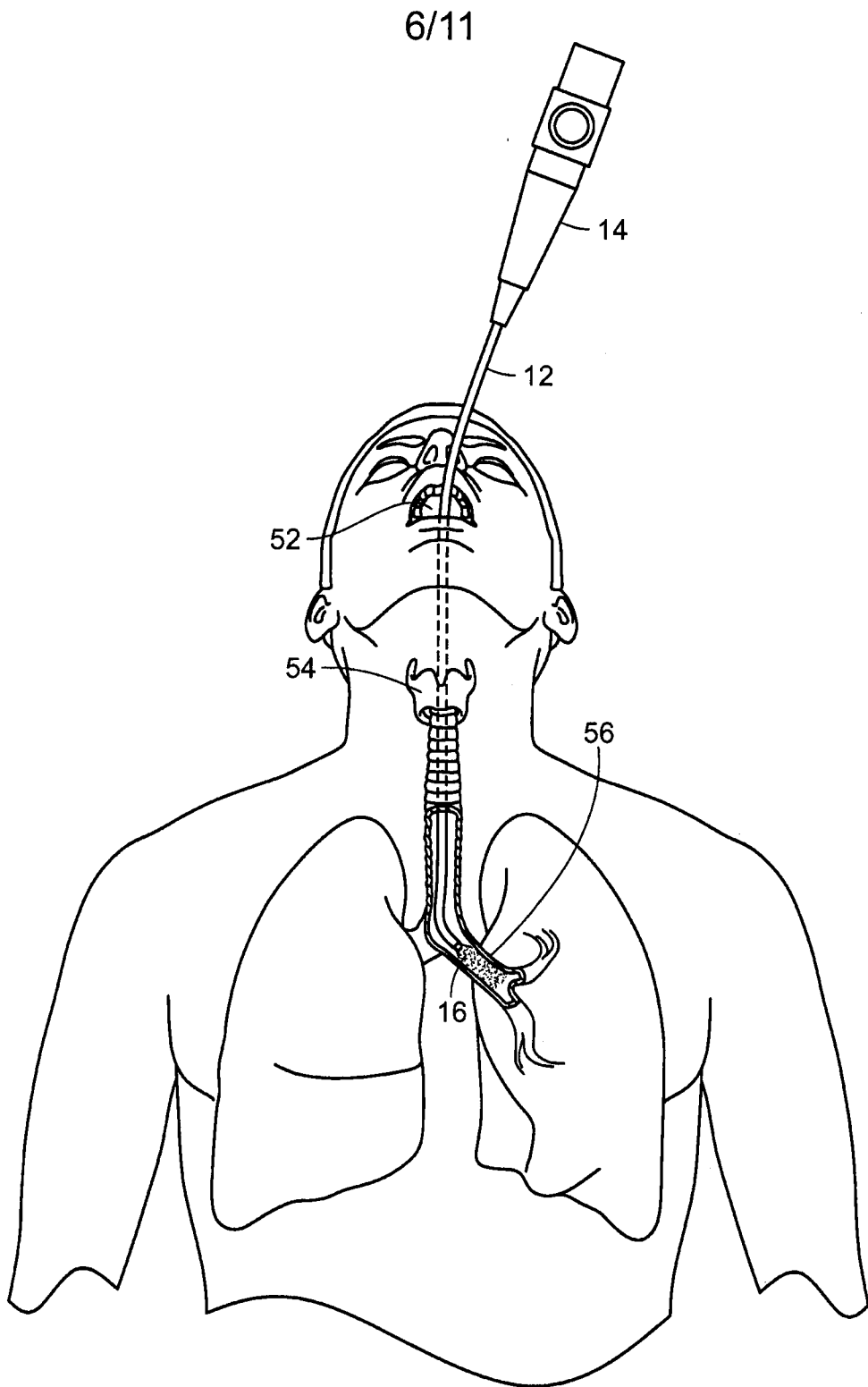

FIG. 8

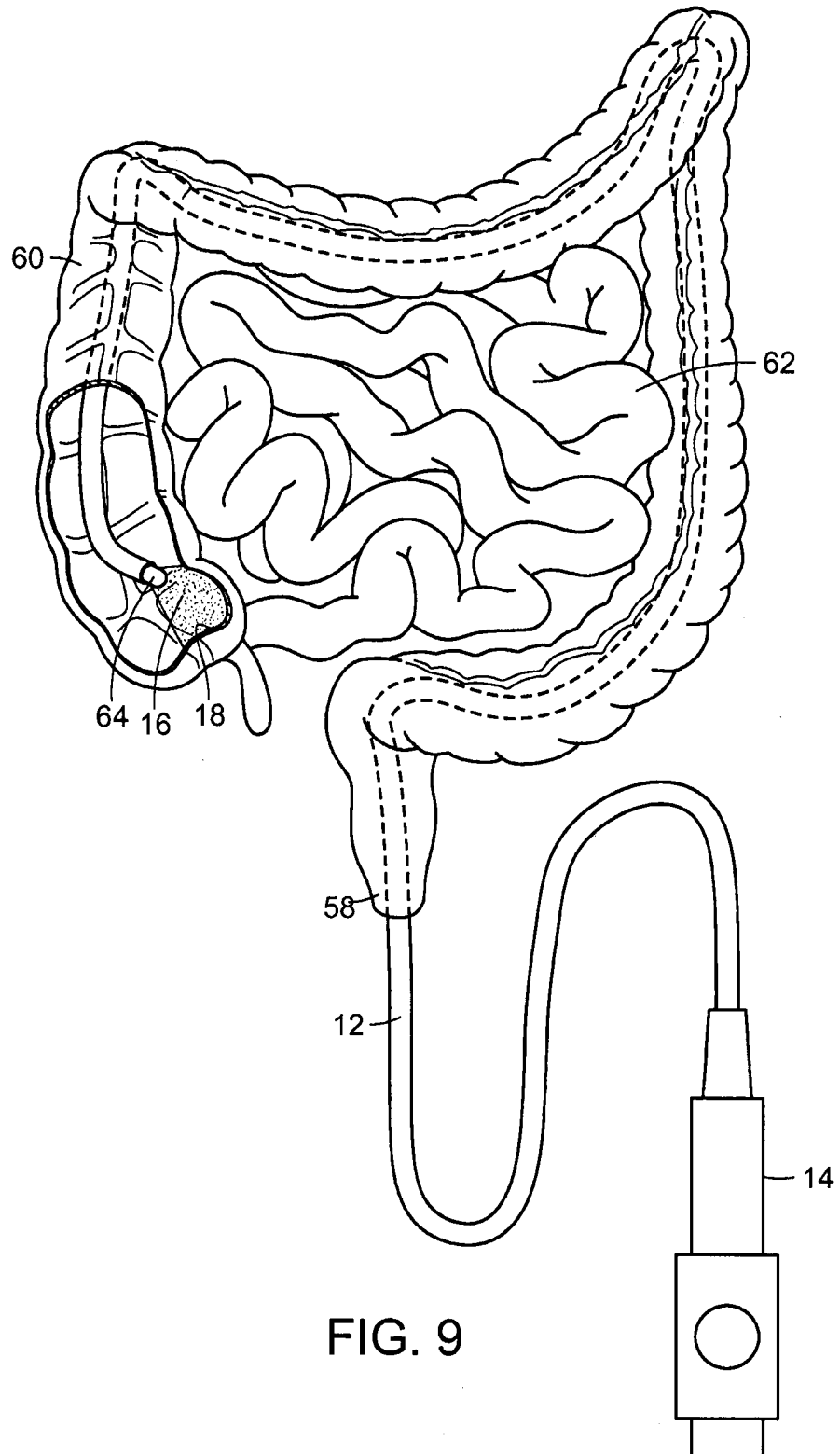

FIG. 9

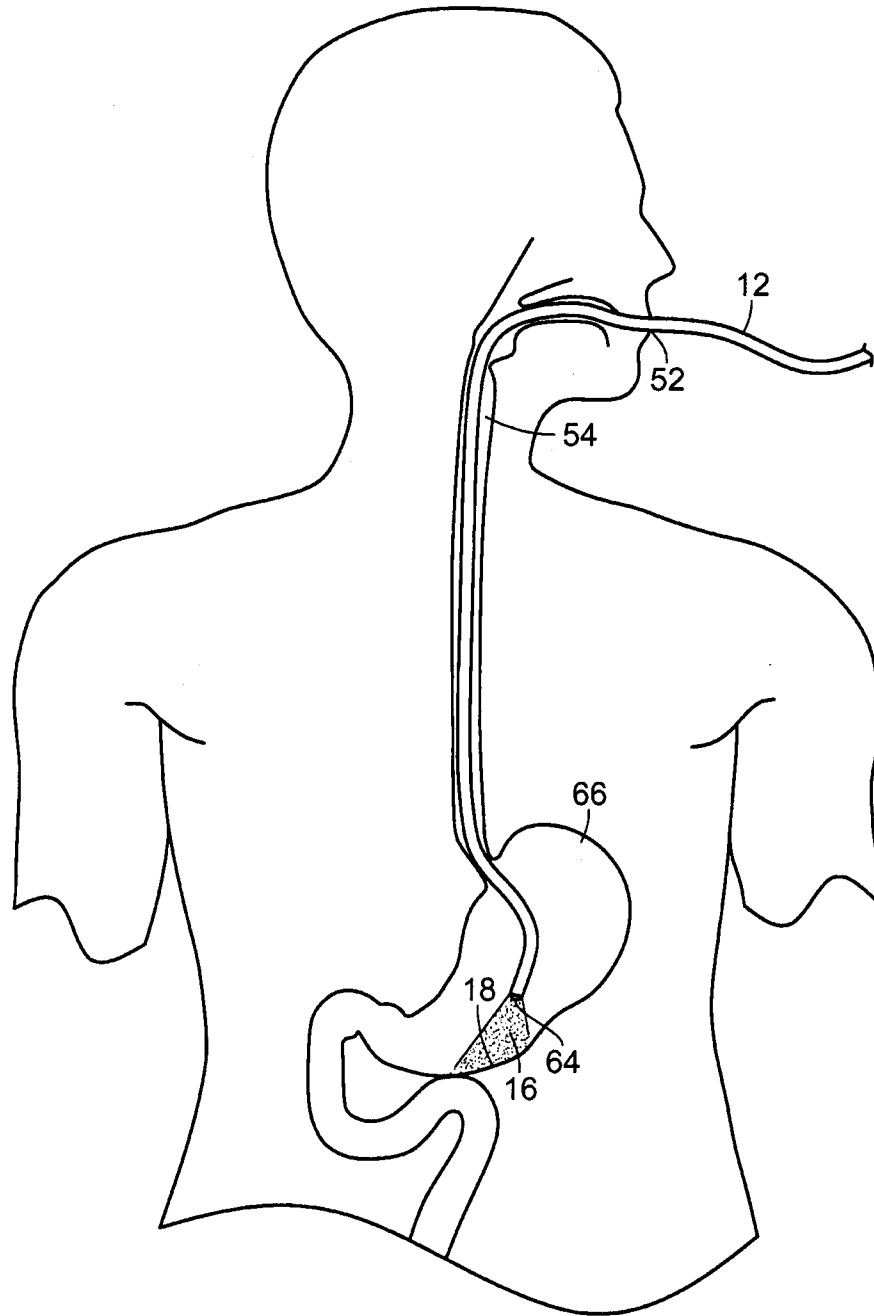

FIG. 10

9/11

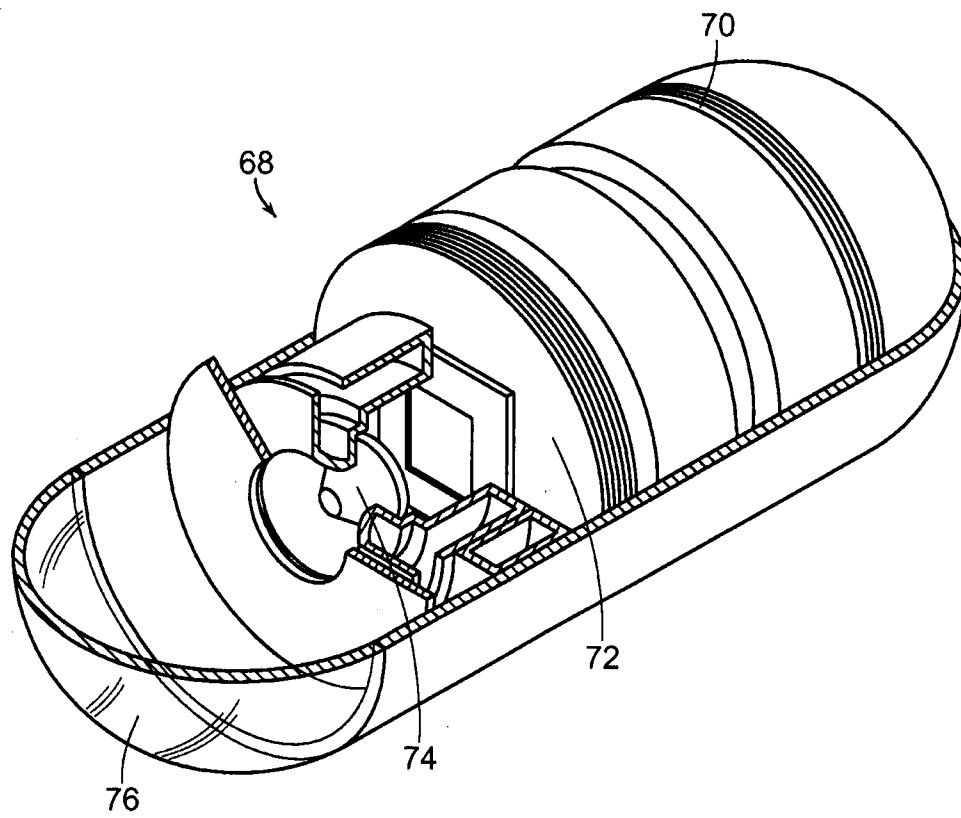

FIG. 11

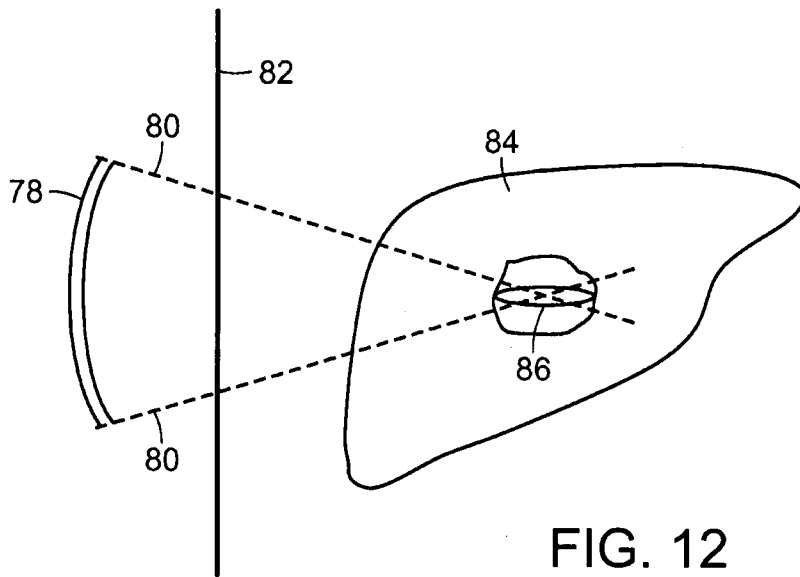

FIG. 12

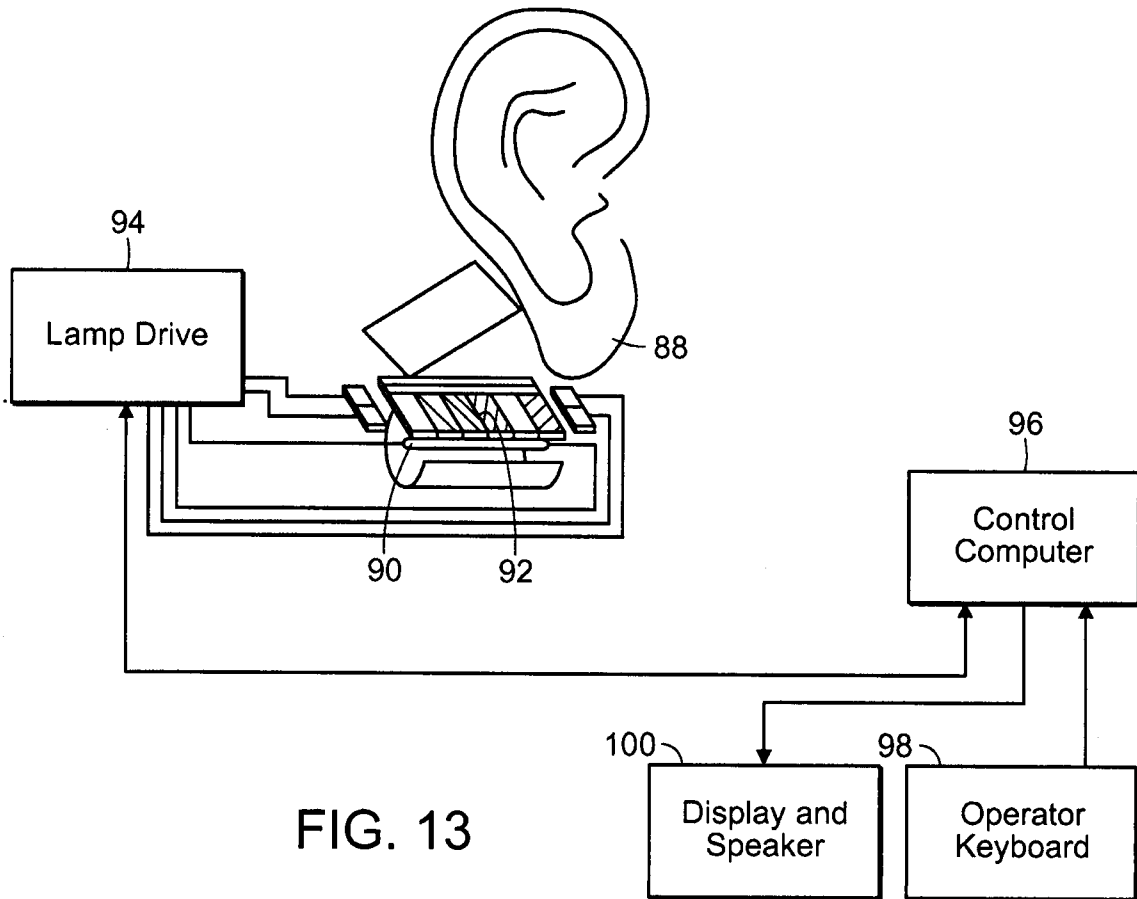

FIG. 13

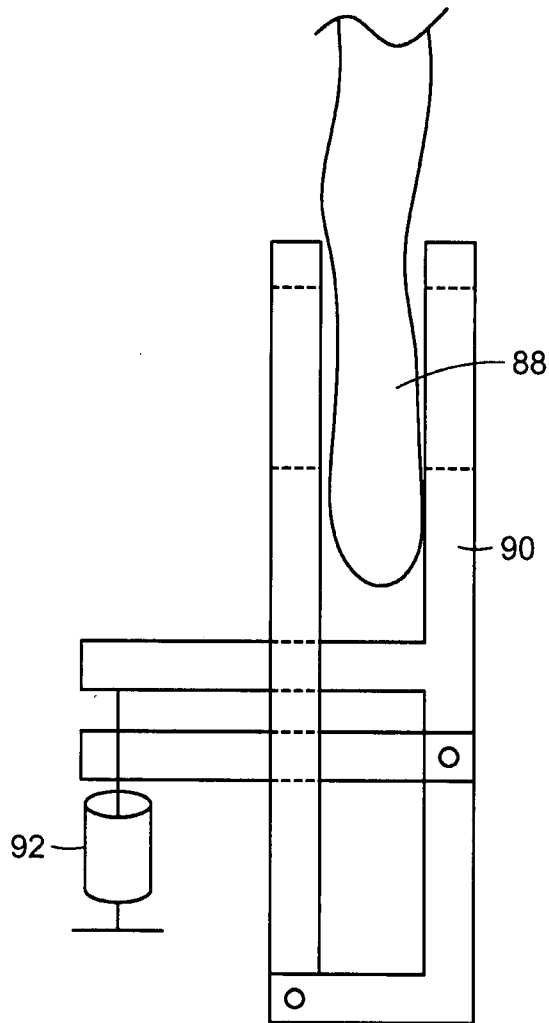

FIG. 14

