

(No Model.)

P. W. DILLON.  
NUT LOCK.

No. 523,976.

Patented Aug. 7, 1894.

Fig. 1.

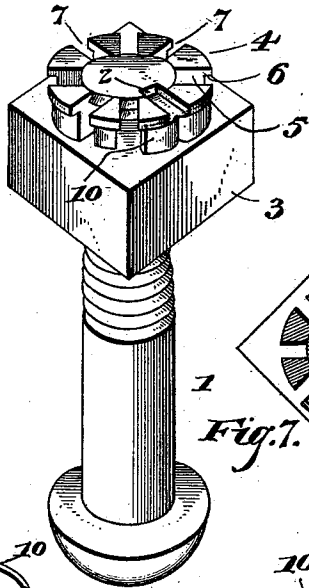

Fig. 2.

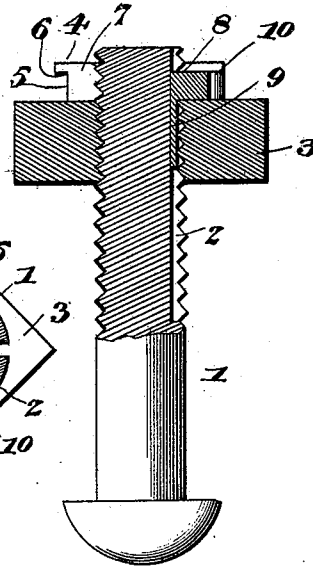

Fig. 7.

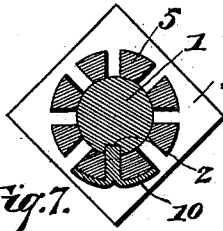

Fig. 3.

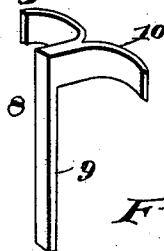

Fig. 4.

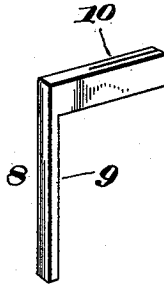

Fig. 5.

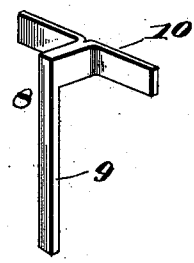
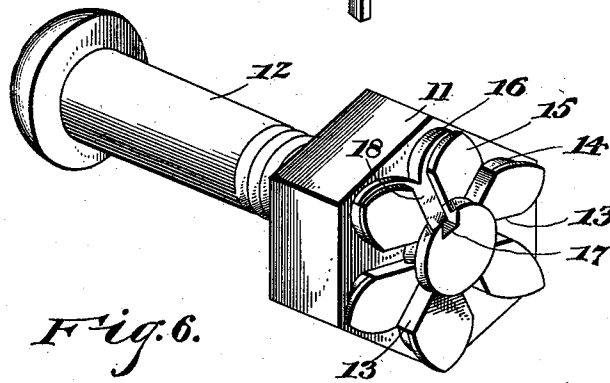

Fig. 6.



Inventor

Patrick W. Dillon,

Witnesses

B. S. Ober.  
John A. Liggins.

By his Attorneys.

C. A. Snow & Co.

# UNITED STATES PATENT OFFICE.

PATRICK W. DILLON, OF DAVENPORT, WASHINGTON.

## NUT-LOCK.

SPECIFICATION forming part of Letters Patent No. 523,976, dated August 7, 1894.

Application filed January 11, 1894. Serial No. 496,521. (No model)

*To all whom it may concern:*

Be it known that I, PATRICK W. DILLON, a citizen of the United States, residing at Davenport, in the county of Lincoln and State of Washington, have invented a new and useful Nut-Lock, of which the following is a specification.

My invention relates to improvements in nut-locks and to that particular class thereof in which the bolt is longitudinally grooved for the accommodation of a key, whose outer end is bent around a projection formed on the face or crown of the nut.

The objects of my invention are to provide a lock, and nut adapted to combine therewith, the latter being so constructed as to engage with the key for locking at various points of rotation of the nut; to provide for convenient unlocking of the nut, if at any time occasion should require it, and the relocking of the same without impairing the lock or the nut; and furthermore and finally, to produce a lock of the class described adapted to be used in overhead work, or any location desired, and yet obviate any possibility of the key slipping from the locking-groove in the bolt and its engagement with the nut.

With these objects in view the invention consists in certain features of construction hereinafter specified and particularly pointed out in the claims.

Referring to the drawings:—Figure 1 is a perspective view of a bolt, nut and lock, embracing my invention. Fig. 2 is a vertical longitudinal sectional view of the same. Fig. 3 is a detail perspective view of the locking key. Figs. 4 and 5 are similar views of a modification of the key, showing the same before and after application. Fig. 6 is a perspective view of a modified construction, or rather, my invention applied to a hexagonal nut. Fig. 7 is a transverse sectional view of the construction shown in Fig. 1, the section being taken through the studs.

Like numerals of reference indicate corresponding parts in all the figures of the drawings.

A bolt 1 has the ordinary threads, and is further provided with a longitudinal groove 2 extending throughout its threaded portion and terminating at the extremity of the bolt. I preferably employ a rectangular or four-

sided nut 3 in connection with the bolt, and form upon the outer face of the same, during its manufacture, an annular flange, the same surrounding the opening in the nut and having the threads of the latter continued therein. This flange is provided on its exterior between the face of the nut and the face of the flange with an annular groove 5, thus producing a peripheral overhanging shoulder 6. The flange is further radially grooved at intervals opposite each of the angles of the nut and between the same as indicated at 7, or at any other desired points.

8 designates a locking key consisting of a straight shank 9 provided at its outer end with an arm, and spring fingers extending in opposite directions from the outer end of the arm of the shank. The key may be constructed of any suitable material, but it, preferably, is composed of a hard, tempered L-shaped shank or portion, and resilient, spring fingers, the latter being capable of engaging under the overhanging shoulder 6 and of exerting a constant pressure upon the headed studs, which are formed out of the flange 4. The spring fingers are curved to conform to the configuration of the grooved portions of the studs.

The manner of using the lock is as follows:—The nut having been run down upon the bolt to the proper point, the shank of the locking key is inserted in the groove, and it will be found that the arm will be in position to be inserted into one of the radial grooves or spaces between the studs. This having been done, while the spring fingers 10 are compressed or pressed together sufficiently to permit it, the spring fingers are released and they spring into engagement with the adjacent headed studs beneath the shoulders thereof. The spring fingers being under the overhanging shoulders of the studs, it will be seen will prevent the key from leaving the groove of the bolt or the nut, and hence my lock is intended for a variety of uses, as for instance, in machinery of different kinds, railway joints, bridge and other iron work, &c. Regardless of the position of the nut, it will be seen, that the key can never accidentally leave the seat, without the spring fingers be drawn together in order to effect a disengagement between them and the overhanging

shoulders of the studs, this, of course, can only be done by intent, and not by accident, whereby the lock is preferably secured.

In Figs. 4 and 5 of the accompanying drawings is illustrated a modification of the locking key, showing the same both before and after application; it is constructed of malleable metal, and the arm of the shank has its outer portion bifurcated to form the fingers. After the shank has been arranged in the groove of the bolt, and the arm fitted in one of the radial grooves, any pointed instrument may be inserted between the branches of the bifurcated portion to separate the same; and the branches are then bent laterally in opposite directions in order to take within the annular grooves of the adjacent studs.

In Fig. 6 I have illustrated my invention as applied to a hexagonal nut, it being understood that the invention is applicable to any form of nut desired. The nut 11 in this figure has the same interior threading as before, whereby it may be threaded upon the bolt 12. The outer face of the nut is at intervals provided with radial grooves 13, said grooves forming a series of intermediate studs 14, which project from the face of the nut. The studs, as before stated are provided with heads 15, and these overlap the sides of the studs forming locking shoulders. The locking key 16 is the same as that heretofore described. I prefer, however, the first construction described, in that it permits of a closer and more perfect adjustment of the nut upon the bolt, and always permits of the locking of the nut through the medium of the key. It is more easily manufactured by producing upon the nut the annular flange at the time of the forming of the nut, which facilitates the subsequent formation of the studs.

It will be seen that the nut may be removed by springing the fingers out of engagement with the heads of the studs or rebending a malleable key, whereby a withdrawal may be had, after which the nut may be reapplied to the bolt, and the key reinserted in its seat.

Changes in the form, proportion and the minor details of construction may be resorted to without departing from the principle or sacrificing any of the advantages of this invention.

What I claim is—

1. The combination of the grooved bolt, a nut having a series of headed studs forming on its outer face and separated by intermediate grooves, and an L-shaped locking key seated in the groove of the bolt and fitting in one of the grooves of the nut and having its outer extremity bent laterally and engaging under the head of an adjacent stud, substantially as described.

2. The combination of a grooved bolt, a nut having an annular flange formed on its outer face, said flange being externally grooved between its outer face and that of the nut, and at intervals radially grooved, and the locking key consisting of an L-shaped shank seated in the groove of the bolt and extending through one of the radial grooves, and provided with oppositely disposed spring fingers engaging the external groove of the flange, substantially as described.

In testimony that I claim the foregoing as my own I have hereto affixed my signature in the presence of two witnesses.

PATRICK W. DILLON.

Witnesses:

A. C. SHAW,  
A. F. LAMBERT.