

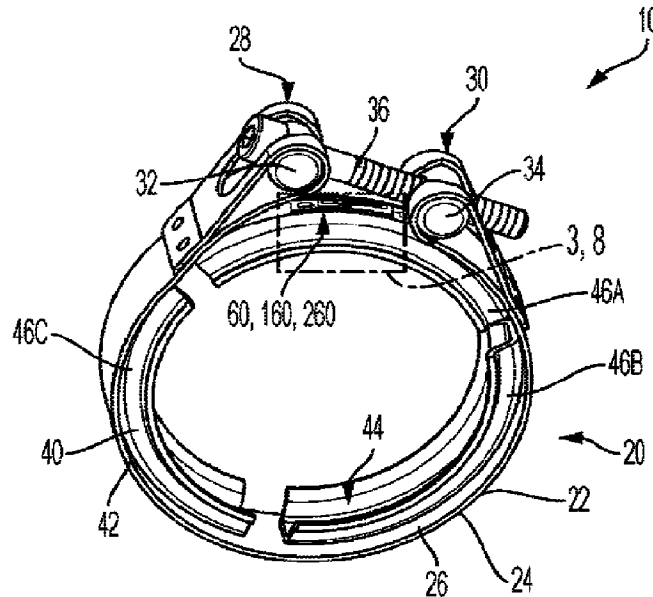

(86) **Date de dépôt PCT/PCT Filing Date:** 2020/06/15
 (87) **Date publication PCT/PCT Publication Date:** 2021/04/08
 (45) **Date de délivrance/Issue Date:** 2024/04/02
 (85) **Entrée phase nationale/National Entry:** 2022/02/14
 (86) **N° demande PCT/PCT Application No.:** US 2020/037760
 (87) **N° publication PCT/PCT Publication No.:** 2021/066896
 (30) **Priorité/Priority:** 2019/09/30 (US62/907,758)

(51) **Cl.Int./Int.Cl. F16L 23/10** (2006.01)
 (72) **Inventeurs/Inventors:**
 PRICE, MARTIN R., US;
 HAGEN, KRISTIAN JAMES, US;
 SAUSEN, KARI ANN, US
 (73) **Propriétaire/Owner:**
 OETIKER NY, INC., US
 (74) **Agent:** KIRBY EADES GALE BAKER

(54) **Titre : CONNECTEUR D'IDENTIFICATION PAR RADIOFREQUENCE**
 (54) **Title: RADIO-FREQUENCY IDENTIFICATION CONNECTOR**



(57) **Abrégé/Abstract:**

A radio-frequency identification (RFID) connector (20), including a connector, including at least one component (22, 40), and a RFID assembly (60) connected to the connector, the RFID assembly including a RFID tag, and at least one contact arranged on the at least one component and electrically connected to the RFID tag, wherein in an unlocked state of the RFID connector, the RFID tag indicates an open state of the RFID assembly, and in a locked state of the RFID connector, the RFID tag indicates a closed state of the RFID assembly.

Date Submitted: 2022/02/14

CA App. No.: 3147975

Abstract:

A radio-frequency identification (RFID) connector (20), including a connector, including at least one component (22, 40), and a RFID assembly (60) connected to the connector, the RFID assembly including a RFID tag, and at least one contact arranged on the at least one component and electrically connected to the RFID tag, wherein in an unlocked state of the RFID connector, the RFID tag indicates an open state of the RFID assembly, and in a locked state of the RFID connector, the RFID tag indicates a closed state of the RFID assembly.

RADIO-FREQUENCY IDENTIFICATION CONNECTOR

FIELD

5 [0001] The present disclosure relates to a connection verifier for a clamp, and, more particularly, to a clamp or connector comprising a radio-frequency identification (RFID) tag that indicates the status of the clamp or a connection via wireless transmission.

BACKGROUND

10 [0002] A clamp is a fastening device used to hold or secure objects tightly together to prevent movement or separation through the application of inward pressure. There are many types of clamps available for many different purposes. Some are temporary, as used to position components while fixing them together, others are intended to be permanent.

15 [0003] One type of clamp, known as a hose clamp or hose clip or hose lock, is a device used to attach and seal a hose into a fitting such as a barb or nipple. Some types of hose clamps include screw/band (worm gear) clamps, spring clamps, wire clamps, ear clamps, v clamps, etc. Often, hose clamps are used to connect hoses or lines to fittings that carry toxic substances, such as refrigerant, fuel, oil, coolant, etc., and are thus a crucial component. As such, it is essential that the clamp or connector be properly secured thereby properly securing the connection (i.e., the hose/fitting connection).

20 [0004] It should be appreciated that clamps or connectors are crucial components of many other connectors and their use does not extend to only fluid connections. For example, clamps may be used in the medical field to secure components various tools or machines during surgical or non-surgical procedures. Clamps or connectors may be used to secure moving bodies together, for example, a trailer to a vehicle.

25 [0005] As such, there is a long-felt need for a connection verifier that ensures that a connection, connector, or clamp is adequately secured. There has also been a long-felt need for a connection verifier that utilizes RFID to ensure that a connection between various components is securely connected.

SUMMARY

[0006] According to aspects illustrated herein, there is provided a radio-frequency identification (RFID) connector, comprising a connector, including at least one component, and a RFID assembly connected to the connector, the RFID assembly including a RFID tag, and at least one contact arranged on the at least one component and electrically connected to the RFID tag, wherein in an unlocked state of the RFID connector, the RFID tag indicates an open state of the RFID assembly, and in a locked state of the RFID connector, the RFID tag indicates a closed state of the RFID assembly.

[0007] In some embodiments, the at least one component comprises a first component including a first end and a second end, and a second component, wherein the at least one contact is arranged on the second component. In some embodiments, in the unlocked state, the first component is not engaged with the at least one contact, and in the locked state, the first component is engaged with the at least one contact. In some embodiments, the first component is an outer ring including an inward facing surface, and the second component is connected to the inward facing surface and includes an outward facing surface, the at least one contact being arranged on the outward facing surface. In some embodiments, the second component comprises one or more segments. In some embodiments, the at least one contact comprises a first contact electrically connected to the at least one component, and a second contact. In some embodiments, in the unlocked state, the second contact is not electrically connected to the at least one component, and in the locked state, the second contact is electrically connected to the at least one component. In some embodiments, the at least one contact comprises a pressure sensitive contact. In some embodiments, the at least one contact comprises a first contact electrically connected to the RFID tag, and a second contact electrically connected to the RFID tag, the second contact being separated from the first contact to form the open state. In some embodiments, in the closed state, the first contact is electrically connected to the second contact. In some embodiments, the RFID tag comprises an antenna, in an open state of the RFID tag, the antenna circuit is open, and in a closed state of the RFID tag, the antenna circuit is closed.

[0008] According to aspects illustrated herein, there is provided a radio-frequency identification (RFID) connector, comprising a connector, including a first component comprising an inward facing surface, a first end, and a second end, and a second component comprising an

outward facing surface, the second component connected to the first component, and a RFID assembly, including a RFID tag, a first contact electrically connected to the RFID tag and the second component, and a second contact electrically connected to the RFID tag and arranged on the outward facing surface, wherein in an unlocked state of the RFID connector, the second contact
5 is not electrically connected to the first component, and in a locked state of the RFID connector, the second contact is electrically connected to the first component.

[0009] In some embodiments, in the unlocked state, the RFID tag indicates an open state of the RFID assembly, and in the locked state, the RFID tag indicates a closed state of the RFID assembly. In some embodiments, the second end is operatively arranged to displace relative to the first end to tighten the connector, and removably engage and electrically connect to the second
10 contact. In some embodiments, the connector is a clamp. In some embodiments, the RFID assembly further comprises a layer, the layer comprising a top surface, wherein the second contact and the RFID tag are arranged on the top surface, and a bottom surface. In some embodiments, the layer comprises an insulating material and the bottom surface is connected to the outward facing
15 surface. In some embodiments, the first contact is arranged on the bottom surface. In some embodiments, the RFID tag comprises an antenna, in the open state, the antenna circuit is open, and in the closed state, the antenna circuit is closed.

[0010] According to aspects illustrated herein, there is provided a radio-frequency identification (RFID) connector, comprising a connector, including an outer ring comprising an inward facing surface, a first end, and a second end, the second end being displaceable relative to
20 the first end, and an inner ring component comprising an outward facing surface, the inner ring component connected to the outer ring, and a RFID assembly arranged on the outward facing surface, the RFID assembly including a RFID tag, a first contact electrically connected to the RFID tag and the outer ring, and a second contact electrically connected to the RFID tag, wherein in an
25 unlocked state of the RFID connector, the second contact is not electrically connected to the outer ring and the RFID tag indicates an open state of the RFID assembly, and in a locked state of the RFID connector, the second contact is electrically connected to the outer ring and the RFID tag indicates a closed state of the RFID assembly.

[0011] These and other objects, features, and advantages of the present disclosure will become readily apparent upon a review of the following detailed description of the disclosure and in view of the drawings.

BRIEF DESCRIPTION OF THE DRAWINGS

5 **[0012]** Various embodiments are disclosed, by way of example only, with reference to the accompanying schematic drawings in which corresponding reference symbols indicate corresponding parts, in which:

Figure 1 is a perspective view of a RFID connector, in an unlocked state;

Figure 2 is a perspective view of the RFID connector shown in Figure 1, in a locked state;

10 Figure 3 is a detail view of the RFID connector taken generally along detail 3 in Figure 1;

Figure 4 is a perspective view of a RFID assembly;

Figure 5 is a perspective view of a RFID assembly;

Figure 6 is a cross-sectional view of the RFID assembly taken generally along line 6-6 in Figure 5;

15 Figure 7 is a perspective view of a RFID assembly;

Figure 8 is a detail view of the RFID connector taken generally along detail 8 in Figure 1;

Figure 9A is a partial cross-sectional schematic view of a RFID assembly in an open state;

and,

20 Figure 9B is a partial cross-sectional schematic view of the RFID assembly shown in Figure 9A, in a closed state.

DETAILED DESCRIPTION

[0013] At the outset, it should be appreciated that like drawing numbers on different drawing views identify identical, or functionally similar, structural elements.

25 **[0014]** Furthermore, it is understood that this disclosure is not limited to the particular methodology, materials and modifications described and as such may, of course, vary.

[0015] Unless defined otherwise, all technical and scientific terms used herein have the same meaning as commonly understood to one of ordinary skill in the art to which this disclosure pertains. It should be understood that any methods, devices or materials similar or equivalent to those described herein can be used in the practice or testing of the example embodiments. The

assembly of the present disclosure could be driven by hydraulics, electronics, pneumatics, and/or springs.

[0016] It should be appreciated that the term “substantially” is synonymous with terms such as “nearly,” “very nearly,” “about,” “approximately,” “around,” “bordering on,” “close to,” “essentially,” “in the neighborhood of,” “in the vicinity of,” etc., and such terms may be used interchangeably as appearing in the specification. It should be appreciated that the term “proximate” is synonymous with terms such as “nearby,” “close,” “adjacent,” “neighboring,” “immediate,” “adjoining,” etc., and such terms may be used interchangeably as appearing in the specification. The term “approximately” is intended to mean values within ten percent of the specified value.

[0017] It should be understood that use of “or” in the present application is with respect to a “non-exclusive” arrangement, unless stated otherwise. For example, when saying that “item x is A or B,” it is understood that this can mean one of the following: (1) item x is only one or the other of A and B; (2) item x is both A and B. Alternately stated, the word “or” is not used to define an “exclusive or” arrangement. For example, an “exclusive or” arrangement for the statement “item x is A or B” would require that x can be only one of A and B. Furthermore, as used herein, “and/or” is intended to mean a grammatical conjunction used to indicate that one or more of the elements or conditions recited may be included or occur. For example, a device comprising a first element, a second element and/or a third element, is intended to be construed as any one of the following structural arrangements: a device comprising a first element; a device comprising a second element; a device comprising a third element; a device comprising a first element and a second element; a device comprising a first element and a third element; a device comprising a first element, a second element and a third element; or, a device comprising a second element and a third element.

[0018] Moreover, as used herein, the phrases “comprises at least one of” and “comprising at least one of” in combination with a system or element is intended to mean that the system or element includes one or more of the elements listed after the phrase. For example, a device comprising at least one of: a first element; a second element; and, a third element, is intended to be construed as any one of the following structural arrangements: a device comprising a first element; a device comprising a second element; a device comprising a third element; a device

comprising a first element and a second element; a device comprising a first element and a third element; a device comprising a first element, a second element and a third element; or, a device comprising a second element and a third element. A similar interpretation is intended when the phrase “used in at least one of:” is used herein. Furthermore, as used herein, “and/or” is intended to mean a grammatical conjunction used to indicate that one or more of the elements or conditions recited may be included or occur. For example, a device comprising a first element, a second element and/or a third element, is intended to be construed as any one of the following structural arrangements: a device comprising a first element; a device comprising a second element; a device comprising a third element; a device comprising a first element and a second element; a device comprising a first element and a third element; a device comprising a first element, a second element and a third element; or, a device comprising a second element and a third element.

[0019] Adverting now to the figures, Figure 1 is a perspective view of RFID connector **10**, in an unlocked state. Figure 2 is a perspective view of RFID connector **10**, in a locked state. Figure 3 is a detail view of RFID connector **10** taken generally along detail **3** in Figure 1. RFID connector **10** generally comprises connector or clamp **20** and RFID assembly **60, 160, 260**. The following description should be read in view of Figures 1-3.

[0020] Connector **20** comprises component or outer ring or band **22** and component or inner ring **40**. Component **22** comprises an outward facing surface, for example, radially outward facing surface **24**, an inward facing surface, for example, radially inward facing surface **26**, end **28**, and end **30**. In some embodiments, end **28** and end **30** are operatively arranged to be displaced toward each other in order to decrease the diameter of connector **20** and squeeze or clamp components together (e.g., the ends of two pipes, tubes, or lines). In some embodiments, and as shown, end **28** comprises a loop and is connected to a component or trunnion, for example, slotted trunnion **32**, and end **30** comprises a loop and is connected to a component or trunnion, for example, threaded trunnion **34**. Screw **36** engages trunnion **32** and trunnion **34** and is operatively arranged to displace trunnion **34** toward and away from trunnion **32** (or operatively arranged to displace trunnion **32** toward and away from trunnion **34**). In some embodiments, screw **36** is threaded and extends through a slot or a through-bore in trunnion **32** and threadably engages threaded trunnion **34**. As screw **36** is rotated in a first direction, threaded trunnion **34** is displaced toward slotted trunnion **32** (or slotted trunnion **32** is displaced toward threaded trunnion **34**). As

screw **36** is rotated in a second direction, opposite the first direction, threaded trunnion **34** is displaced away from slotted trunnion **32** (or slotted trunnion **32** is displaced away from threaded trunnion **34**). In some embodiments, trunnion **32** is threaded and trunnion **34** is slotted.

[0021] Component **40** is connected to and arranged (radially) inward from component **22**.

5 In some embodiments, and as shown, component **40** comprises one or more segments, for example, segments **46A-C**. In some embodiments, connector **40** only comprises one segment, for example, segment **46A**. In some embodiments, connector **20** does not comprise a connector or inner ring, and comprises only connector (i.e., outer ring) **22**. Segments **46A-C** are connected to radially inward facing surface **26** and are circumferentially spaced there about. Each of segments **46A-C**
10 comprises an outward facing surface, for example radially outward facing surface **42**, which is connected to radially inward facing surface **26**, and an inward facing surface, for example, radially inward facing surface **44**. Radially inward facing surface **44** may be linear (e.g., cylindrical) or curvilinear (e.g., U-shaped) in order to clamp or secure two components together. For example, as shown, radially inward facing surface **44** is U-shaped such that two pipe ends having flanges can
15 be secured within the contour of radially inward facing surface **44**. However, it should be appreciated that any clamp or connector may be used in place of connector **20**, and that the present disclosure should not be limited to only that which is shown in the drawings.

[0022] RFID assembly **60, 160, 260** is arranged on a radially outward facing surface of the one or more segments, for example, on radially outward facing surface **42** of segment **46A**. RFID
20 assembly **60, 160, 260** comprises at least one contact that is electrically connected to component **22**, as will be described in greater detail below. In some embodiments, RFID assemblies **60** and **160** comprise contacts **80A-B** and **180A-B**, respectively. As best shown in Figure 3, contact **80B, 180B** is electrically connected to radially outward facing surface **42** of segment **46A** of component **40**. Since segment **46A** is also electrically connected to component **22**, it follows that contact **80B, 180B**
25 **180B** is electrically connected to component **22**. Contact **80A, 180A** is non-electrically connected to radially outward facing surface **42** of segment **46A**. As shown, contact **80A, 180A** is arranged on insulating layer **62, 162** thereby preventing electrical connection between contact **80A, 180A** and segment **46A**, and thus component **22**, as will be described in greater detail below. As component **22** is tightened (i.e., end **28** is displaced closer to end **30**), radially inward facing surface
30 **26** of component **22** contacts and electrically connects to contact **80A, 180A**, thereby completing

the circuit between contacts **80A, 180A** and **80B, 180B**. Upon completion of the circuit, RFID tag **70, 170** indicates that the connection is secure.

[0023] Figure 4 is a perspective view of RFID assembly **60**. RFID assembly **60** generally comprises at least one layer (e.g., layer **62**), RFID tag **70**, and at least one contact (e.g., contact **80A** and/or contact **80B**). In some embodiments, RFID assembly **60** is a RFID label that is connected to a first component of a connector, wherein the connector is arranged to connect two elements. It should be appreciated that RFID assembly **60** may be used to ensure any type of connection, for example, a fluid connection, a constant-velocity (CV) joint, a trailer hitch connection, electrical connections, etc. The following description should be read in view of Figures 1-4.

[0024] Layer **62** comprises surface **64** and surface **66** and is operatively arranged to be secured to a component of connector **20**, for example, radially outward facing surface **42** of component **40**. In some embodiments, surface **64** comprises an adhesive and secures RFID tag **70** and/or contact **80A** to connector **20** (e.g., segment **46A**). It should be appreciated that layer **62** need not be connected to connector **20** via adhesives, but rather can be connected and/or applied using any other suitable means, for example, string, tape, hook and loop fastener, solder, welding, etc. In some embodiments, layer **62** is an insulator. In an unconnected state, as shown in Figures 1 and 3, contact **80A** is non-electrically connected to segment **46A** and component **22**, and contact **80B** is electrically connected to segment **46A** and component **22**.

[0025] RFID assembly **60** may further comprise an additional ferrite layer connected to top surface **66** (not shown) operatively arranged as a platform or base for RFID tag **70** and/or contact **80A**. In some embodiments, RFID assembly **60** further comprises layer **68**. Layer **68** is operatively arranged to cover and protect RFID tag **70**. As shown in Figure 4, layer **68** completely covers RFID tag **70** and at least partially covers contact **80A**. However, it is required that at least a portion of contact **80A** is exposed, for example, exposed portion **82**, such that it is capable of engaging and electrically connecting to end **28** of component **22**, as will be described in greater detail below.

[0026] RFID tag **70** is arranged on surface **66** and comprises integrated circuit (IC) or chip **72** and antenna **74**. In some embodiments, RFID tag **70** comprises a passive RFID tag. In some embodiments, RFID tag **70** comprises an active RFID tag (and further comprises a power source).

In some embodiments, RFID tag **70** comprises a semi-passive RFID tag. In some embodiments, RFID tag **70** is preprogrammed such that it transmits information, for example, a unique identification (UID) number, the state of RFID assembly **60** (i.e., open or closed), etc. Antenna **74** is connected at a first end to IC **72** at antenna radio-frequency (RF) input **LA**, and at a second end to IC **72** at antenna RF input **LB**, via conductors **76A** and **76B**, respectively. RFID tag **70** is further connected to contact **80A** and contact **80B**. Specifically, conductor **78A** connects contact **80A** with IC **72** at ground pin **GND** and conductor **78B** connects contact **80B** with IC **72** at detector pin **DP**. [0027] Contact **80A** is separated from contact **80B**. Specifically, contact **80A** is arranged on surface **66** of layer **62** and contact **80B** is not arranged on layer **62**. Contact **80B** is arranged on radially outward facing surface **42** and electrically connected to component **40** and component **22** of connector **20**. In some embodiments, contact **80B** is arranged on radially inward facing surface **26** and electrically connected to component **40** and component **22** of connector **20**. It should be appreciated that contact **80B** may be connected to component **40** and/or component **22** via any suitable means, for example, adhesives, string, tape, hook and loop fastener, solder, welding, etc. In some embodiments, contacts **80A** and **80B** are electrical conductors. It should be appreciated that, in the unlocked state, as shown in Figures 1 and 3, contact **80B** is always electrically connected to component **22** and contact **80A** is not electrically connected to component **22**. When connector **20** is properly secured, end **28** of component **22** is pulled into engagement and electrical connection with contact **80A**. In some embodiments, component **22** and/or component **40** comprises an electrically conductive material (e.g., metal). As such, when end **28** is engaged with contact **80A**, component **22** completes the circuit between contacts **80A-B** and IC **72** and causes RFID tag **70** to become enabled (i.e., RFID tag **70** is capable of being powered by an electromagnetic field generated by an external device (not shown)) or switch to a closed state (from an open state). Prior to completion of the circuit, namely, electrically connecting contact **80A** directly with contact **80B**, RFID tag **70** is not enabled (i.e., RFID tag **70** is not capable of being powered by an electromagnetic field generated by the external device) or in some embodiments, it indicates an open status. When the circuit is completed (i.e., component **22** and/or component **40** directly connects contact **80A** and contact **80B** as shown in Figure 2), an external device such as a RFID reader will detect that RFID tag **70** is enabled, or in a closed state, thereby indicating that RFID connector **10** is properly connected. Put another way, when RFID tag **70** is enabled, the

RFID reader will identify that RFID tag **70** exists and thus determine that RFID connector **10** is properly connected. When the circuit is not completed (i.e., contact **80A** is not directly connected to contact **80B**), the RFID reader will not detect an enabled RFID tag **70** thereby indicating that RFID connector **10** is not properly connected. Put in yet another way, when RFID tag **70** is disabled, the RFID reader will not identify that RFID tag **70** exists and thus determine that RFID connector **10** is not properly connected.

[0028] In some embodiments, RFID tag **70** is always enabled and can be detected and read by a RFID reader regardless of whether contacts **80A** and **80B** are connected. In such embodiments, when contacts **80A** and **80B** are not directly connected, for example via component **22** and/or component **40**, RFID tag **70** is capable of transmitting, to a RFID reader, certain information. Such information may include, but is not limited to, a UID number (e.g., for the RFID tag, the connector form, etc.), size number, model number, serial number, status of RFID tag **70** (i.e., open or closed), uniform resource locator (URL), station identification (i.e., manufacturing LOT number), date/time stamp, description, etc. Put another way, independent of whether contacts **80A** and **80B** are connected, RFID tag **70** will always transmit certain data (e.g., a UID number, a status, etc.) provided it is properly functioning. Thus, RFID tag **70** is preprogrammed to always transmit at least a UID number and a status (i.e., open or closed), for example, using hexadecimal data or a value. This is important because it allows the user to scan a given RFID tag to determine if it is properly functioning (i.e., if the RFID tag is properly transmitting data then it is properly functioning) as well as to determine its current state (i.e., open or closed). When contacts **80A** and **80B** are connected, for example, via component **22** and/or component **40**, RFID tag **70** transmits data indicating a closed status. In some embodiments, RFID tag **70** indicates a first value (e.g., a first hexadecimal value) for an open state and a second value (e.g., second hexadecimal value) for a closed state, the second value being different from the first value. It should be appreciated that RFID tag **70** may include any programming suitable for indicating that it is properly functioning and a differentiation between an open state and a closed state, and that the present disclosure should not be limited to just the use of the hexadecimal system.

[0029] Figure 5 is a perspective view of RFID assembly **160**. Figure 6 is a cross-sectional view of RFID assembly **160** taken generally along line **6-6** in Figure 5. RFID assembly **160** generally comprises at least one layer (e.g., layer **162**), RFID tag **170**, and at least one contact (e.g.,

contact **180A** and/or contact **180B**). In some embodiments, RFID assembly **160** is a RFID label that is connected to a first component of a connector, wherein the connector is arranged to connect two elements. It should be appreciated that RFID assembly **160** may be used to ensure any type of connection, for example, a fluid connection, a CV joint, a trailer hitch connection, electrical connections, etc. The following description should be read in view of Figures 1-6.

[0030] Layer **162** comprises surface **164** and surface **166** and is operatively arranged to be secured to a component of connector **20**, for example, radially outward facing surface **42** of component **40** (e.g., segment **46A**). In some embodiments, surface **164** comprises an adhesive and secures RFID tag **170** and/or contact **180A** and/or contact **180B** to connector **20**. It should be appreciated that layer **162** need not be connected to connector **20** via adhesives, but rather can be connected and/or applied using any other suitable means, for example, string, tape, hook and loop fastener, solder, welding, etc. In some embodiments, layer **162** is an insulator. In an unconnected state, as shown in Figures 1 and 3, contact **180A** is non-electrically connected to segment **46A** and component **22**, and contact **180B** is electrically connected to segment **46A** and component **22**.

[0031] RFID assembly **160** may further comprise an additional ferrite layer connected to top surface **166** (not shown) operatively arranged as a platform or base for RFID tag **170** and/or contact **180A**. In some embodiments, RFID assembly **160** further comprises layer **168**. Layer **168** is operatively arranged to cover and protect RFID tag **170** and/or contact **180A**. As shown in Figures 5-6, layer **168** completely covers RFID tag **170** and at least partially covers contact **180A**. However, it is required that at least a portion of contact **180A** is exposed, for example, exposed portion **182**, such that it is capable of engaging and electrically connecting to end **28** of component **22**, as will be described in greater detail below.

[0032] RFID tag **170** is arranged on surface **166** and comprises IC or chip **172** and antenna **174**. In some embodiments, RFID tag **170** comprises a passive RFID tag. In some embodiments, RFID tag **170** comprises an active RFID tag (and further comprises a power source). In some embodiments, RFID tag **170** comprises a semi-passive RFID tag. In some embodiments, RFID tag **170** is preprogrammed such that it transmits information, for example, a UID number, the state of RFID assembly **160** (i.e., open or closed), etc. Antenna **174** is connected at a first end to IC **172** at antenna RF input **LA**, and at a second end to IC **172** at antenna RF input **LB**, via conductors **176A** and **176B**, respectively. RFID tag **170** is further connected to contact **180A** and contact **180B**.

Specifically, conductor **178A** connects contact **180A** with IC **172** at ground pin **GND** and conductor **178B** connects contact **180B** with IC **172** at detector pin **DP**.

[0033] Contact **180A** is separated from contact **180B**. Specifically, contact **180A** is arranged on surface **166** of layer **162** and contact **180B** is arranged on surface **164** of layer **162**.

5 Contact **180B** is arranged on radially outward facing surface **42** and electrically connected to component **40** and component **22** of connector **20**. In some embodiments, contacts **180A** and **180B** are electrical conductors. It should be appreciated that, in the unlocked state, as shown in Figures 1 and 3, contact **180B** is always electrically connected to component **22** (through segment **46A**) and contact **180A** is not electrically connected to component **22**. When connector **20** is properly
10 secured, end **28** of component **22** is pulled into engagement and electrical connection with contact **180A**. In some embodiments, component **22** and/or component **40** comprises an electrically conductive material (e.g., metal). As such, component **22** completes the circuit between contacts **180A-B** and IC **172** and causes RFID tag **170** to become enabled (i.e., RFID tag **170** is capable of being powered by an electromagnetic field generated by an external device (not shown)) or switch
15 to a closed state (from an open state). Prior to completion of the circuit, namely, electrically connecting contact **180A** directly with contact **180B**, RFID tag **170** is not enabled (i.e., RFID tag **170** is not capable of being powered by an electromagnetic field generated by the external device) or in some embodiments, it indicates an open status. When the circuit is completed (i.e., component **22** and/or component **40** directly connects contact **180A** and contact **180B** as shown in Figure 2),
20 an external device such as a RFID reader will detect that RFID tag **170** is enabled, or in a closed state, thereby indicating that RFID connector **10** is properly connected. Put another way, when RFID tag **170** is enabled, the RFID reader will identify that RFID tag **170** exists and thus determine that RFID connector **10** is properly connected. When the circuit is not completed (i.e., contact **180A** is not directly connected to contact **180B**), the RFID reader will not detect an enabled RFID
25 tag **170** thereby indicating that RFID connector **10** is not properly connected. Put in yet another way, when RFID tag **170** is disabled, the RFID reader will not identify that RFID tag **170** exists and thus determine that RFID connector **10** is not properly connected.

[0034] In some embodiments, RFID tag **170** is always enabled and can be detected and read by a RFID reader regardless of whether contacts **180A** and **180B** are connected. In such
30 embodiments, when contacts **180A** and **180B** are not directly connected, for example via

component **22** and/or component **40**, RFID tag **170** is capable of transmitting, to a RFID reader, certain information. Such information may include, but is not limited to, a UID number (e.g., for the RFID tag, the connector, etc.), size number, model number, serial number, status of RFID tag **170** (i.e., open or closed), URL, station identification (i.e., manufacturing LOT number), date/time stamp, description, etc. Put another way, independent of whether contacts **180A** and **180B** are connected, RFID tag **170** will always transmit certain data (e.g., a UID number, a status, etc.) provided it is properly functioning. Thus, RFID tag **170** is preprogrammed to always transmit at least a UID number and a status (i.e., open or closed), for example, using hexadecimal data or a value. This is important because it allows the user to scan a given RFID tag to determine if it is properly functioning (i.e., if the RFID tag is properly transmitting data then it is properly functioning) as well as to determine its current state (i.e., open or closed). When contacts **180A** and **180B** are connected, for example, via component **22** and/or component **40**, RFID tag **170** transmits data indicating a closed status. In some embodiments, RFID tag **170** indicates a first value (e.g., a first hexadecimal value) for an open state and a second value (e.g., second hexadecimal value) for a closed state, the second value being different from the first value. It should be appreciated that RFID tag **170** may include any programming suitable for indicating that it is properly functioning and a differentiation between an open state and a closed state, and that the present disclosure should not be limited to just the use of the hexadecimal system.

[0035] Figure 7 is a perspective view of RFID assembly **260**. Figure 8 is a detail view of RFID connector **10** taken generally along detail **8** in Figure 1. RFID assembly **260** generally comprises at least one layer (e.g., layer **262**), RFID tag **270**, and at least one contact (e.g., contact **280**). In some embodiments, RFID assembly **260** is a RFID label that is connected to a connector or clamp, wherein the connector or clamp is arranged to connect two elements together. It should be appreciated that RFID assembly **260** may be used to ensure any type of connection, for example, a fluid connection, a CV joint, a trailer hitch connection, electrical connections, etc. The following description should be read in view of Figures 1-3 and 7-9B.

[0036] Layer **262** comprises surface **264** and surface **266** and is operatively arranged to be secured to a component of connector **20**, for example, radially outward facing surface **42** of component **40** (e.g., segment **46A**). In some embodiments, surface **264** comprises an adhesive and secures RFID tag **270** and/or contact **280** to connector **20**. It should be appreciated that layer **262**

need not be connected to connector **20** via adhesives, but rather can be connected and/or applied using any other suitable means, for example, string, tape, hook and loop fastener, solder, welding, etc. In some embodiments, layer **262** is an insulator.

[0037] RFID assembly **260** may further comprise an additional ferrite layer connected to top surface **266** (not shown) operatively arranged as a platform or base for RFID tag **270** and/or contact **280**. In some embodiments, RFID assembly **260** further comprises layer **268**. Layer **268** is operatively arranged to cover and protect RFID tag **270** and/or contact **280**. As shown in Figure 7, layer **268** completely covers RFID tag **270** and at least partially covers contact **280**. However, it is required that at least a portion of contact **280** is exposed, for example, exposed portion **282**, such that it is capable of engaging and electrically connecting to end **28** of component **22**, as will be described in greater detail below.

[0038] RFID tag **270** is arranged on surface **266** and comprises IC or chip **272** and antenna **274**. In some embodiments, RFID tag **270** comprises a passive RFID tag. In some embodiments, RFID tag **270** comprises an active RFID tag (and further comprises a power source). In some embodiments, RFID tag **270** comprises a semi-passive RFID tag. In some embodiments, RFID tag **270** is preprogrammed such that it transmits information, for example, a UID number, the state of RFID assembly **260** (i.e., open or closed), etc. Antenna **274** is connected at a first end to IC **272** at antenna RF input **LA**, and at a second end to IC **272** at antenna RF input **LB**, via conductors **276A** and **276B**, respectively. RFID tag **270** is further connected to contact **280**. Specifically, conductor **278A** connects contact **280** with IC **272** at ground pin **GND** and conductor **278B** connects contact **280** with IC **272** at detector pin **DP**.

[0039] Contact **280** is arranged on surface **266** of layer **262**. Contact **280** is arranged on radially outward facing surface **42**. Contact **280** is operatively arranged to engage with component **22**, for example, end **28**. In some embodiments, contact **280** is a pressure sensitive contact. When RFID connector **10** is properly connected, end **28** engages contact **280** and applies pressure thereto. In some embodiments, connector **20** comprises a metal. In some embodiments, connector **20** comprises a non-metallic material such as a polymer or an elastomer. It should be appreciated that connector **20** may comprise any material suitable to apply pressure to contact **280**. Once a sufficient pressure is applied to contact **280**, the circuit is completed between conductors **278A** and **278B** and IC **272** and causes RFID tag **270** to become enabled (i.e., RFID tag **270** is capable

of being powered by an electromagnetic field generated by an external device (not shown)) or indicate a closed state. Prior to completion of the circuit, namely, electrically connecting the ends of conductors **278A** and **278B**, RFID tag **270** is not enabled (i.e., RFID tag **270** is not capable of being powered by an electromagnetic field generated by the external device) or indicates an open state. When the circuit is completed (i.e., connector **20** applies a sufficient pressure to contact **280** thereby electrically connecting conductor **278A** directly with conductor **278B**), an external device such as a RFID reader will detect that RFID tag **270** is enabled or in a closed state thereby indicating that RFID connector **10** is properly connected. Put another way, when RFID tag **270** is enabled, the RFID reader will identify that RFID tag **270** exists and thus determine that RFID connector **10** is properly connected. When the circuit is not completed (i.e., the ends of conductors **278A** is not directly connected to contact **278B**), the RFID reader will not detect an enabled RFID tag **270** thereby indicating that RFID connector **10** is not properly connected. Put in yet another way, when RFID tag **270** is disabled, the RFID reader will not identify that RFID tag **270** exists and thus determine that RFID connector **10** is not properly connected.

[0040] In some embodiments, RFID tag **270** is always enabled and can be detected and read by a RFID reader regardless of whether conductive layers **290** and **294** (i.e., conductors **278A** and **278B**) are in direct contact. In such embodiments, and as previously described, when conductive layers **290** and **294** (i.e., conductors **278A** and **278B**) are not directly connected, for example from the force of component **22**, RFID tag **270** is capable of transmitting, to a RFID reader, certain information. Such information may include, but is not limited to, a UID number, size number, model number, serial number, status of RFID tag **270** (i.e., open or closed), URL, station identification, date/time stamp, description, etc. Put another way, independent of whether conductive layers **290** and **294** (i.e., conductors **278A** and **278B**) are connected, RFID tag **270** will always transmit data (e.g., a UID number, a status, etc.) provided it is properly functioning. Thus, RFID tag **270** is preprogrammed to always transmit at least a UID number and a status (i.e., open or closed), for example, using hexadecimal data or a value. This is important because it allows the user to scan a given RFID tag to determine if it is properly functioning (i.e., if the RFID tag is properly transmitting data then it is properly functioning) as well as to determine its current state (i.e., open or closed). When conductive layers **290** and **294** (i.e., conductors **278A** and **278B**) are connected, for example, by applying a suitable force **F** to layer **294** via component **22** (e.g., end

28), RFID tag 270 transmits data indicating a closed status. In some embodiments, RFID tag 270 indicates a first value (e.g., a first hexadecimal value) for an open state and a second value (e.g., a second hexadecimal value) for a closed state, the second value being different from the first value. It should be appreciated that RFID tag 270 may include any programming suitable for indicating that it is properly functioning and a differentiation between an open state and a closed state, and that the present disclosure should not be limited to just the use of the hexadecimal system.

[0041] Figure 9A is a partial cross-sectional schematic view of RFID assembly 260 in an open (or disabled) state, in accordance with some embodiments of the present disclosure. It should be appreciated that this is only one embodiment of a pressure sensitive contact, and that various other pressure sensitive contacts that are known in the art or developed in the future may be used. Contact 280 comprises conductive layer 290, insulating layer 292, and conductive layer 294. Conductive layer 290 is arranged on surface 266 of layer 262. In some embodiments, conductive layer 290 is arranged on an additional ferrite layer arranged on surface 266 (not shown). In some embodiments, conductive layer 290 is arranged on radially outward facing surface 42 of segment 46A (i.e., layer 262 is not included). Insulating layer 292 is arranged on top of layer 290. Conductive layer 294 is arranged on top of insulating layer 292. Insulating layer 292 is operatively arranged to separate conductive layers 290 and 294 until a sufficient force F is applied to conductive layer 294, as will be described in greater detail below. Conductor 278A connects ground pin GND with conductive layer 294 and conductor 278B connects detection pin DP with conductive layer 290. In some embodiments, conductor 278A connects ground pin GND with conductive layer 290 and conductor 278B connects detection pin DP with conductive layer 294. As shown in Figure 9A, conductors 278A and 278B remain unconnected and thus RFID tag 270 will indicate an open state or remains disabled (i.e., a RFID reader would not detect that RFID tag 270 exists). As such, in either case, the RFID reader will indicate that RFID connector 10 is not properly secured.

[0042] Figure 9B is a partial cross-sectional schematic view of RFID assembly 260 shown in Figure 9A, in a closed (or enabled) state. When a sufficient force F is applied to conductive layer 294, for example via component 22, conductive layer 294 is displaced through insulating layer 292 and contacts conductive layer 290. When conductive layer 294 contacts conductive layer 290, conductors 278A and 278B are electrically connected completing the circuit and RFID tag

270 indicates a closed state or is enabled (i.e., RFID tag 270 is capable of being powered by an electromagnetic field generated by the RFID reader). As such, in either case, the RFID reader will indicate that RFID connector 10 is properly secured. As can be envisioned from the figures, as end 28 is displaced toward end 30, end 28 is forced down onto RFID assembly 260 and applies force
5 F to contact 280, specifically layer 294.

[0043] It should be appreciated that the RFID tags and assemblies described herein, for example, RFID tags 70 170, and 270 and RFID assemblies 60, 160, and 260, may utilize any suitable radio frequency range. In some embodiments, RFID tags 70, 170, and 270 comprise low frequency (LF) RFID tags operating in the 30 KHz to 300 KHz range, and have a read range of up
10 to 10 cm. While LF RFID tags have a shorter read range and slower data read rate than other technologies, they perform better in the presence of metal or liquids (which can interfere with other types of RFID tag transmissions). Common standards for LF RFID include ISO 14223 and ISO/IEC 18000-2. In some embodiments, RFID tags 70 170, and 270 comprise high frequency (HF) RFID tags operating in the 3 MHz to 30 MHz range and provide reading distances of 10 cm
15 to 1 m. In such embodiments, RFID tags 70 170, and 270 may even be near-field communication (NFC) tags since NFC technology is based on HF RFID. Common standards for HF RFID include ISO 15693, ECMA-340, ISO/IEC 18092 (for NFC), ISO/IEC 14443A and ISO/IEC 14443 (for MIFARE and other smart card solutions). In some embodiments, RFID tags 70 170, and 270
20 comprise ultra-high frequency (UHF) RFID operating in the 300 MHz to 2 GHz range and provide reading distances of up to 12 m. A well-known standard for UHF RFID is EPCglobal Gen2/ISO 18000-6C. Furthermore, in some embodiments, a single RFID reader is capable of detecting and receiving data from a plurality of RFID tags, not just one.

[0044] It will be appreciated that various aspects of the disclosure above and other features and functions, or alternatives thereof, may be desirably combined into many other different
25 systems or applications. Various presently unforeseen or unanticipated alternatives, modifications, variations, or improvements therein may be subsequently made by those skilled in the art.

REFERENCE NUMERALS

	10	RFID connector		80A	Contact
	20	Connector or clamp		80B	Contact
5	22	Component or outer ring or band		82	Exposed portion
	24	Radially outward facing surface		160	RFID assembly (or label)
	26	Radially inward facing surface	35	162	Layer
	28	End		164	Surface
	30	End		166	Surface
10	32	Component or trunnion		168	Layer
	34	Component or trunnion		170	RFID tag
	36	Screw or connecting member	40	172	IC (or chip)
	40	Component or inner ring		174	Antenna
	42	Radially outward facing surface		176A	Conductor
15	44	Radially inward facing surface		176B	Conductor
	46A	Segment		178A	Conductor
	46B	Segment	45	178B	Conductor
	46C	Segment		180A	Contact
	60	RFID assembly (or label)		180B	Contact
20	62	Layer		182	Exposed portion
	64	Surface		260	RFID assembly (or label)
	66	Surface	50	262	Layer
	68	Layer		264	Surface
	70	RFID tag		266	Surface
25	72	IC (or chip)		268	Layer
	74	Antenna		270	RFID tag
	76A	Conductor	55	272	IC (or chip)
	76B	Conductor		274	Antenna
	78A	Conductor		276A	Conductor
30	78B	Conductor		276B	Conductor

	278A	Conductor		294	Layer
	278B	Conductor		LA	Antenna RF input
	280	Contact		LB	Antenna RF input
	282	Exposed portion		GND	Ground pin
5	290	Layer	10	DP	Detection pin
	292	Layer		F	Force

CLAIMS

What Is Claimed Is:

1. A radio-frequency identification (RFID) connector, comprising:
a connector, including:
a first component comprising an inward facing surface, a first end, and a second end; and,
a second component comprising an outward facing surface, the second component connected to the first component; and,
a RFID assembly, including:
a RFID tag;
a first contact electrically connected to the RFID tag and the second component;
and,
a second contact electrically connected to the RFID tag and arranged on the outward facing surface;
wherein:
in an unlocked state of the RFID connector, the second contact is not electrically connected to the first component; and,
in a locked state of the RFID connector, the second contact is electrically connected to the first component.
2. The RFID connector as recited in Claim 1, wherein:
in the unlocked state, the RFID tag indicates an open state of the RFID assembly; and,
in the locked state, the RFID tag indicates a closed state of the RFID assembly.
3. The RFID connector as recited in Claim 1, wherein the second end is operatively arranged to displace relative to the first end to:
tighten the connector; and,

removably engage and electrically connect to the second contact.

4. The RFID connector as recited in Claim 1, wherein the connector is a clamp.
5. The RFID connector as recited in Claim 1, wherein the RFID assembly further comprises a layer, the layer comprising:
 - a top surface, wherein the second contact and the RFID tag are arranged on the top surface;
 - and,
 - a bottom surface.
6. The RFID connector as recited in Claim 5, wherein the layer comprises an insulating material and the bottom surface is connected to the outward facing surface.
7. The RFID connector as recited in Claim 5, wherein the first contact is arranged on the bottom surface.
8. The RFID connector as recited in Claim 2, wherein:
 - the RFID tag comprises an antenna;
 - in the open state, the antenna is open; and,
 - in the closed state, the antenna is closed.
9. The RFID connector as recited in Claim 1, wherein:
 - the first component is an outer ring; and,
 - the second component is an inner ring.
10. The RFID connector as recited in Claim 1, wherein:
 - in the unlocked state, the first component is not engaged with the second contact; and,
 - in the locked state, the first component is engaged with the second contact.

11. The RFID connector as recited in Claim 1, further comprising a screw operatively arranged to displace end and end toward each other to decrease the diameter of connector.
12. The RFID connector as recited in Claim 1, wherein the second component comprises one or more segments.
13. The RFID connector as recited in Claim 1, wherein at least one of the first contact and the second contact comprises a pressure sensitive contact.
14. The RFID connector as recited in Claim 1, wherein the second contact is separated from the first contact to form the open state.
15. The RFID connector as recited in Claim 14, wherein, in the closed state, the first contact is electrically connected to the second contact.

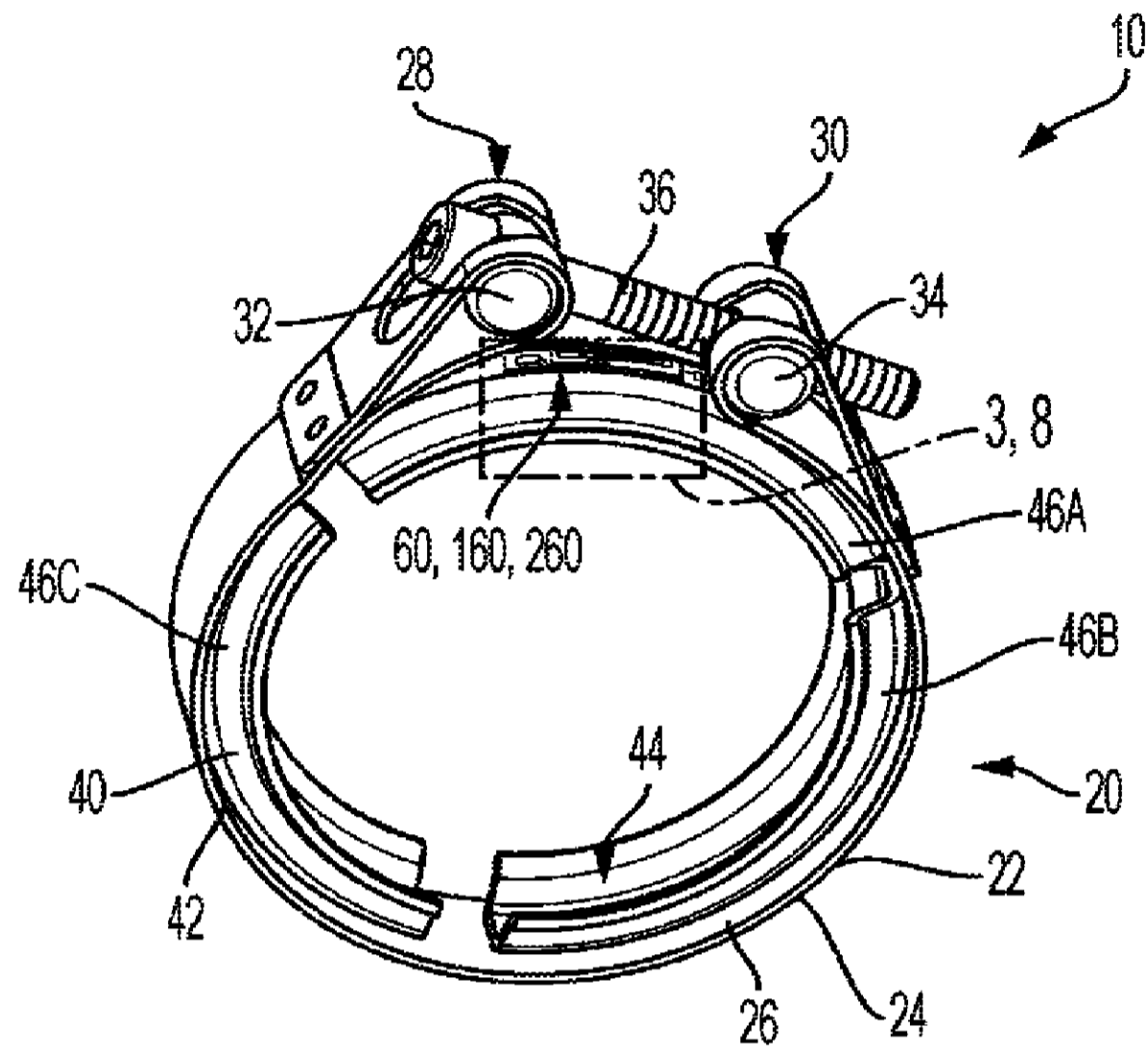

FIG. 1

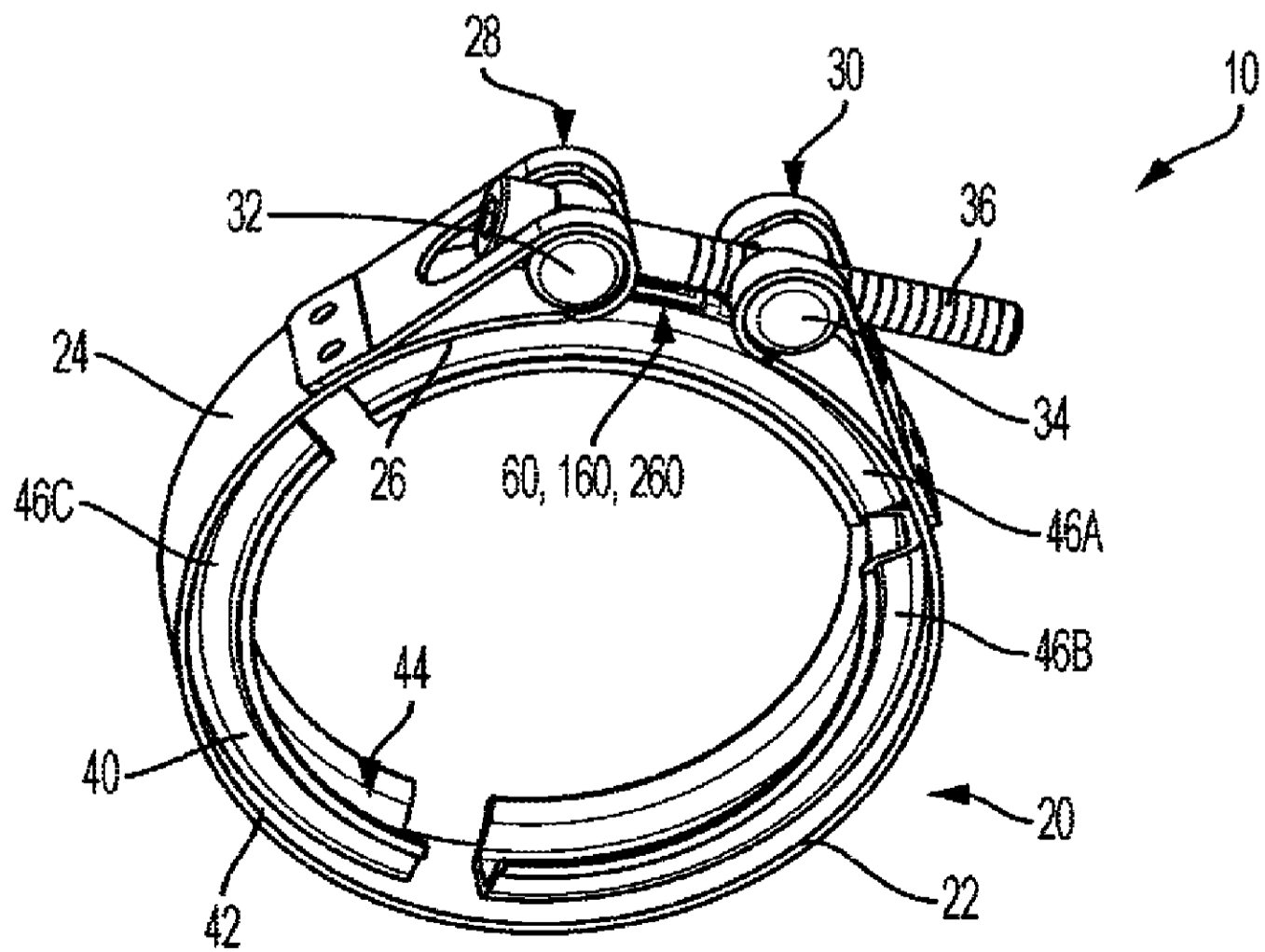

FIG. 2

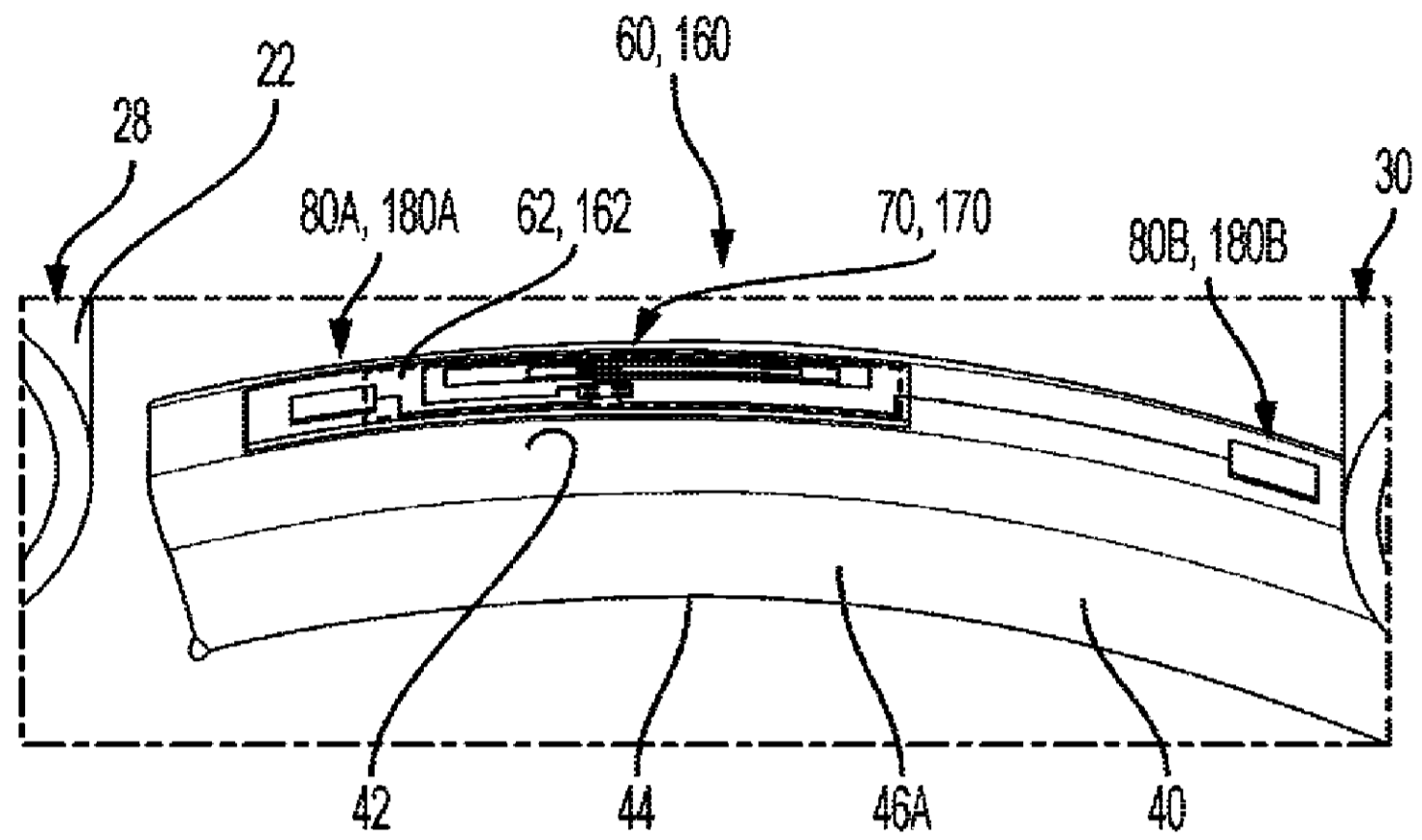

FIG. 3

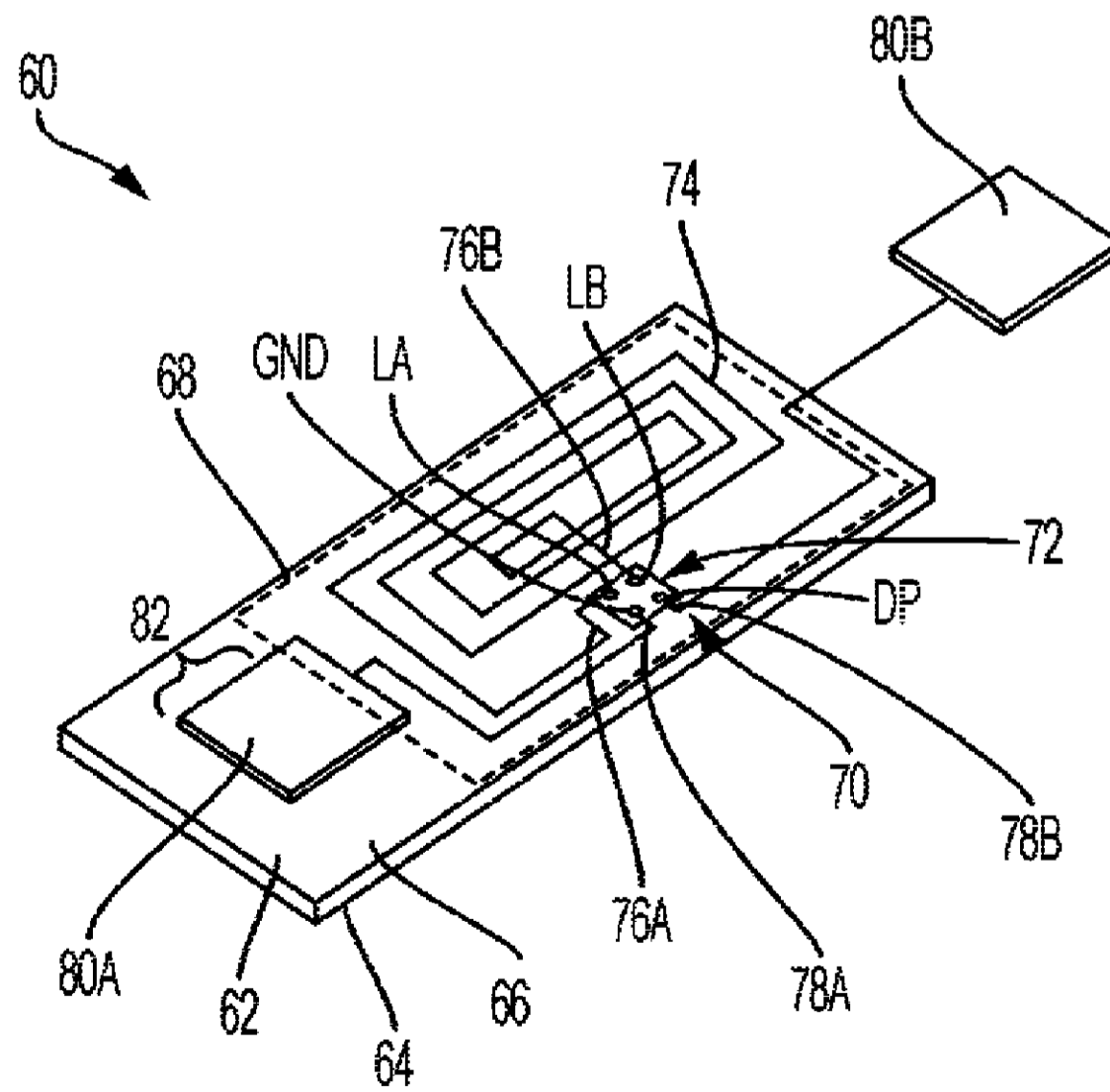

FIG. 4

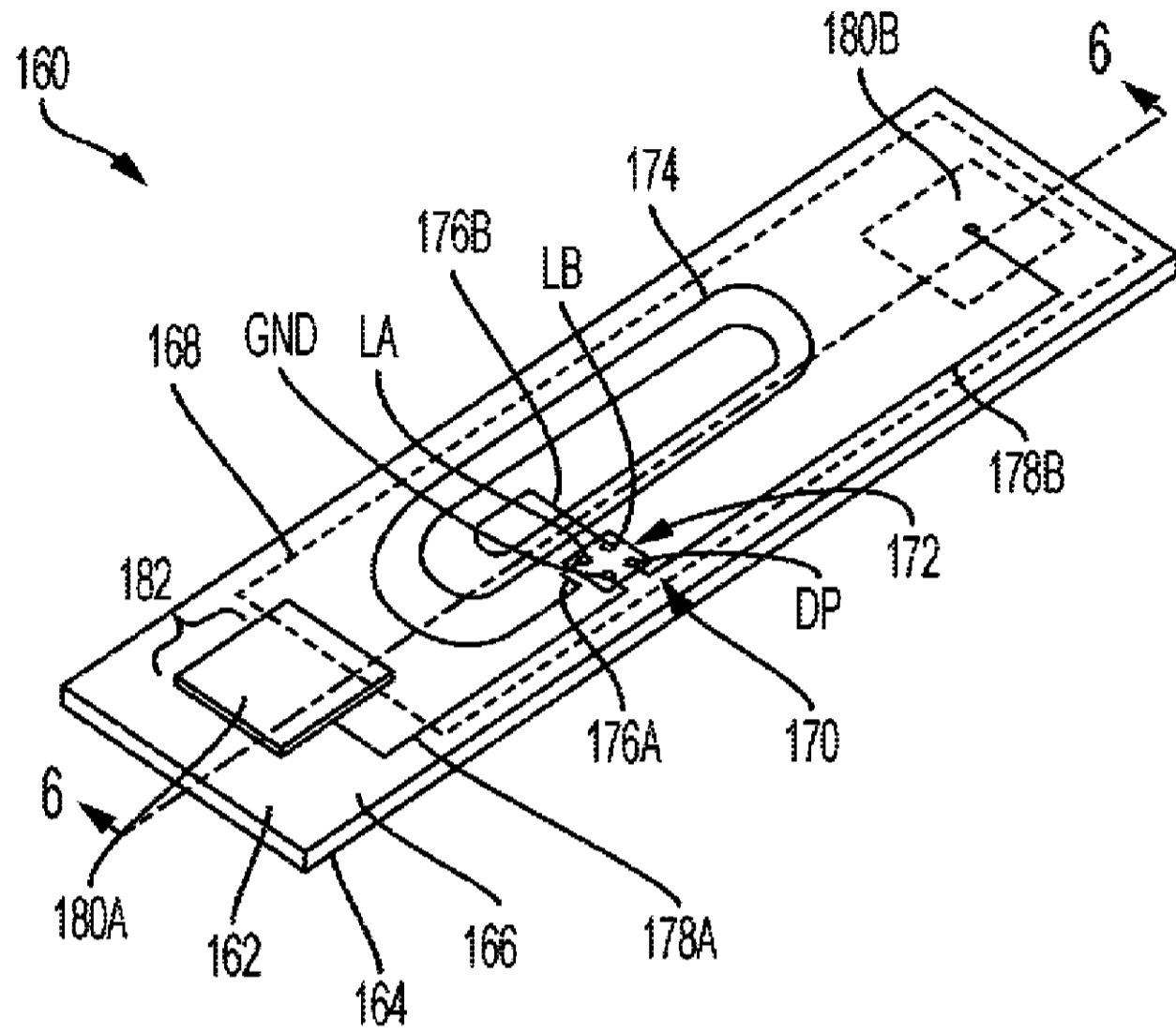

FIG. 5

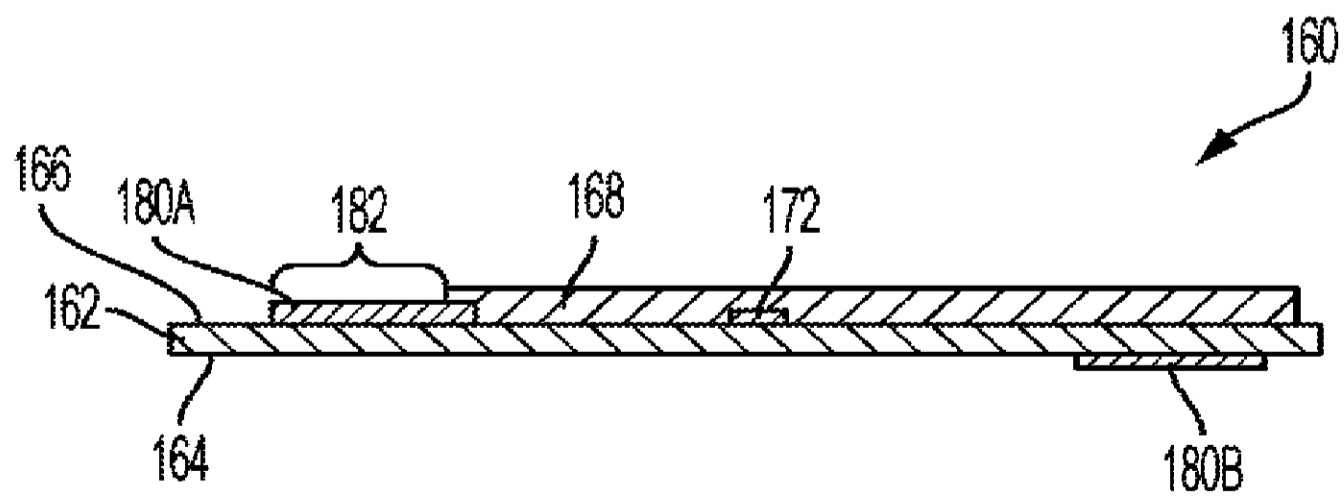

FIG. 6

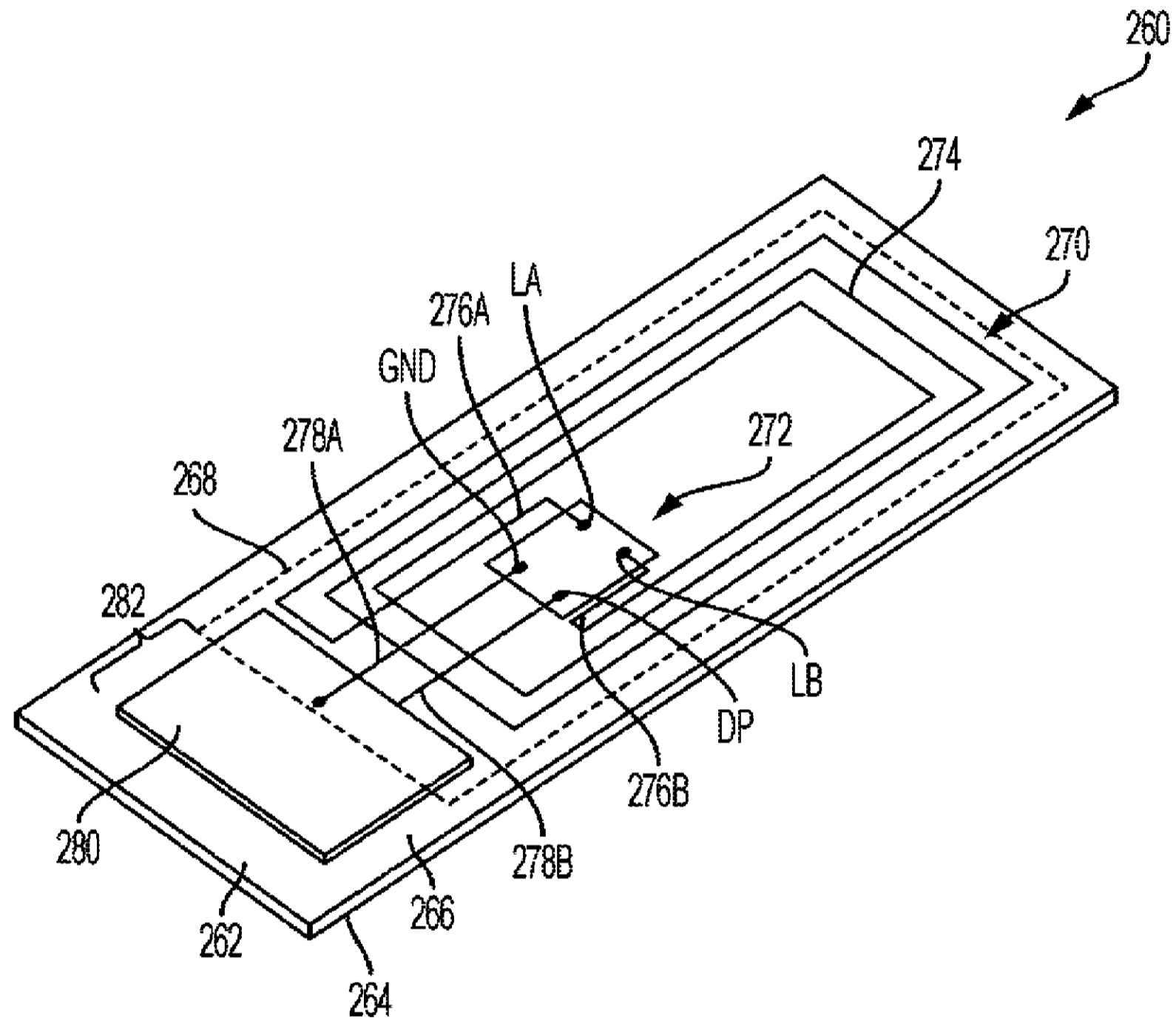

FIG. 7

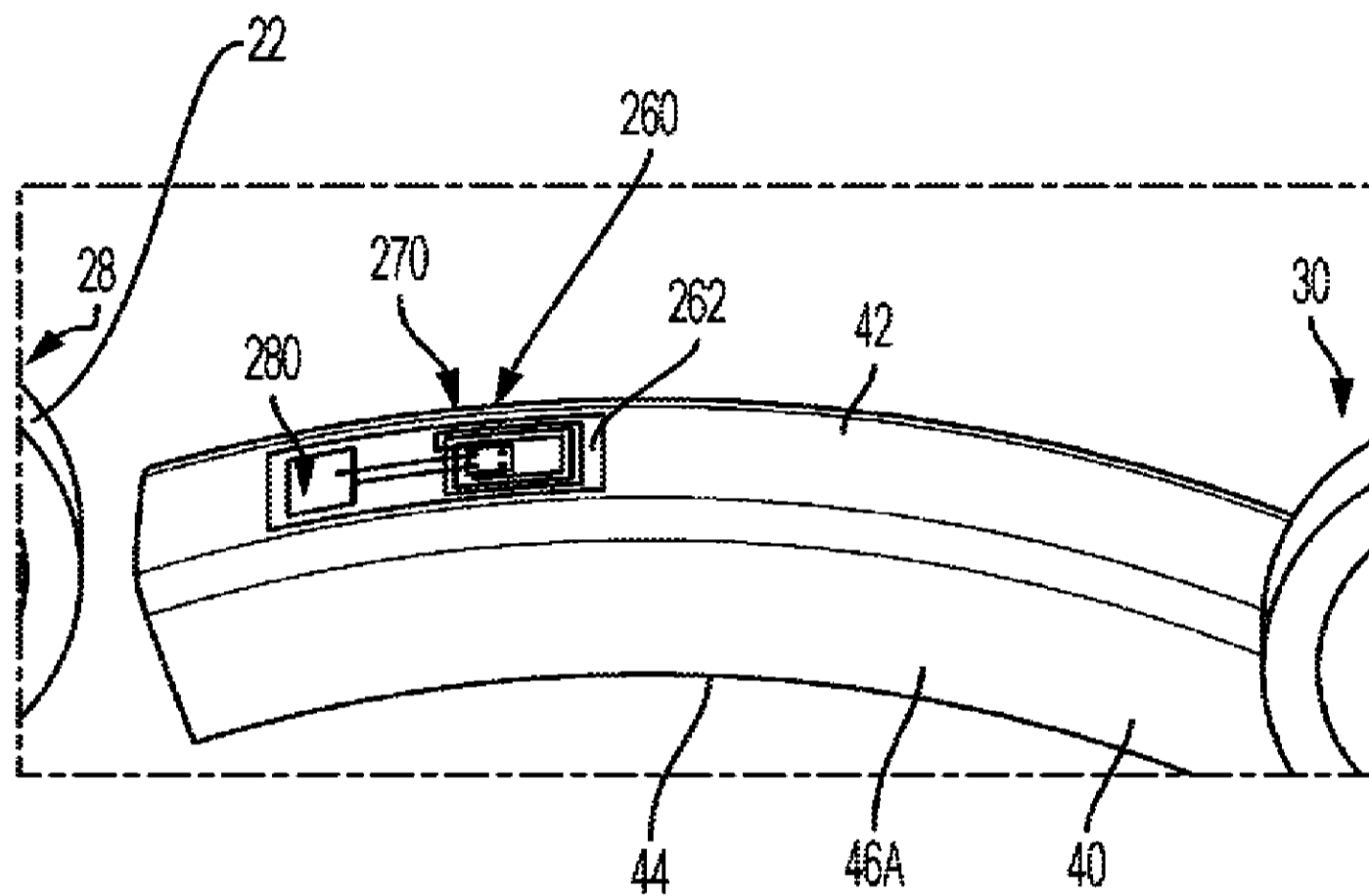

FIG. 8

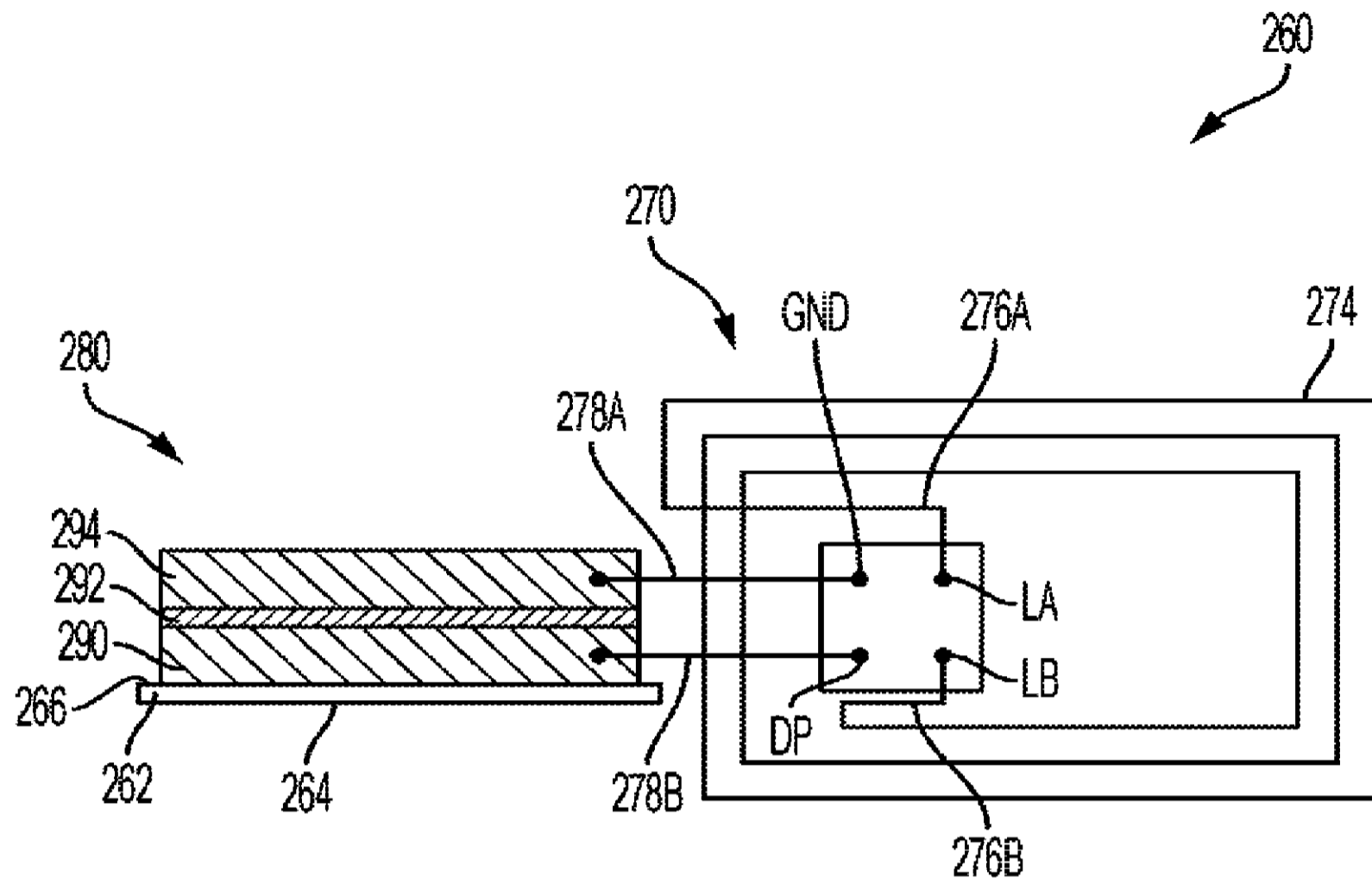

FIG. 9A

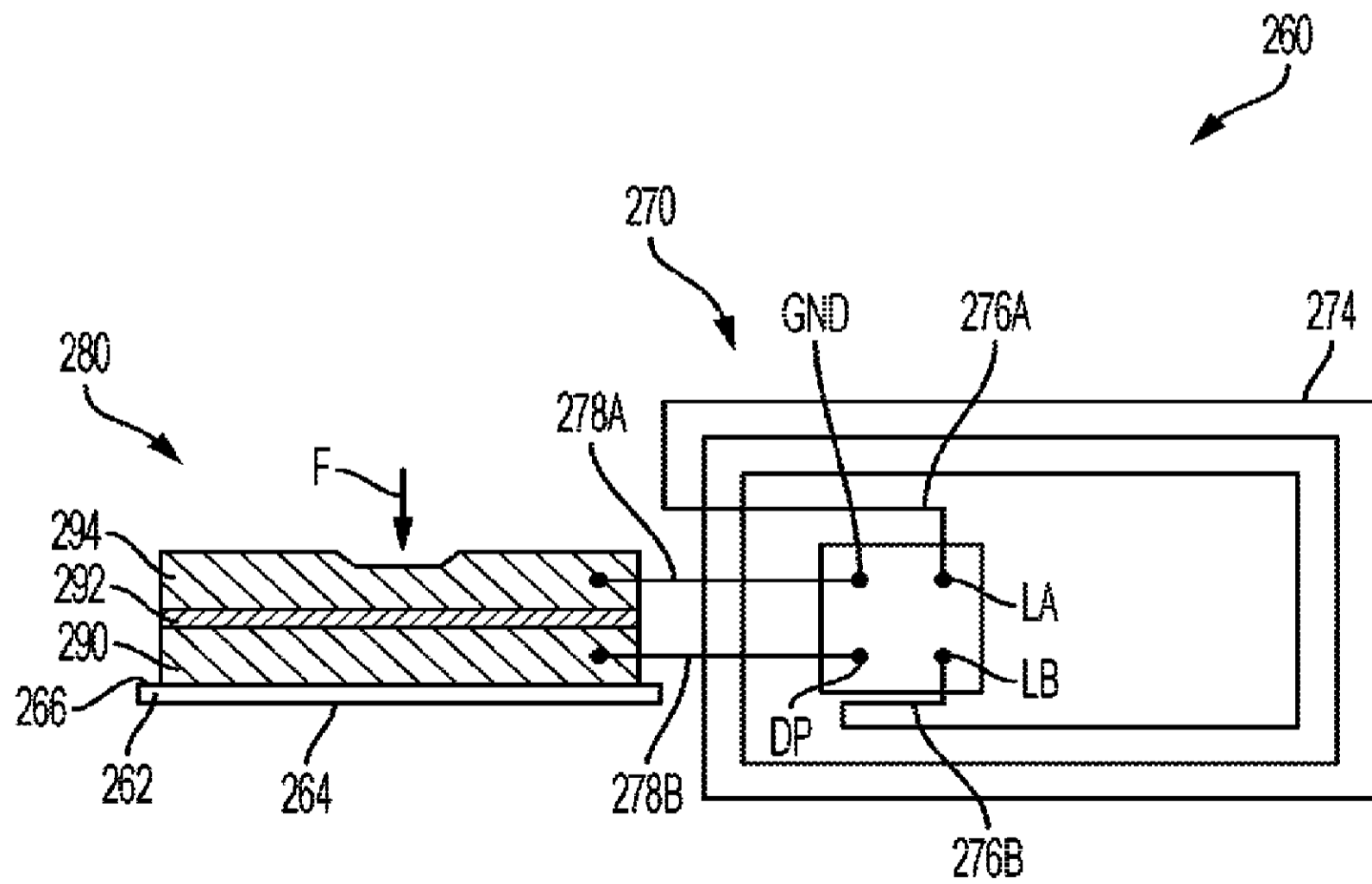

FIG. 9B

