

June 27, 1961

R. G. HARE

2,989,815

AUTOMATIC CHOKE DEVICE FOR SHOTGUNS

Filed Aug. 15, 1957

2 Sheets-Sheet 2

Fig. 3.

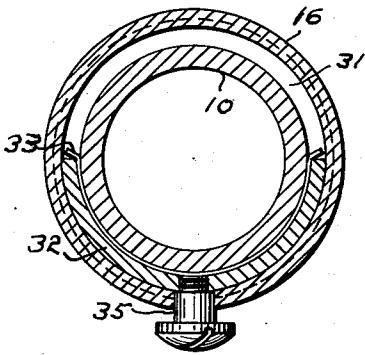

Fig. 4.

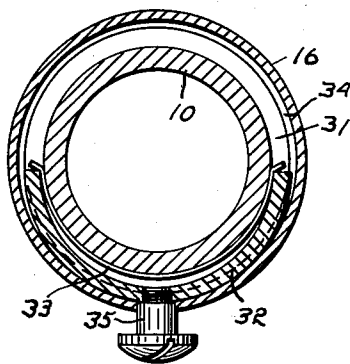

Fig. 5.

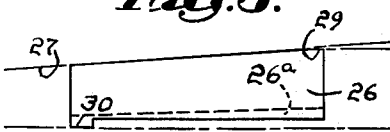

Fig. 6.

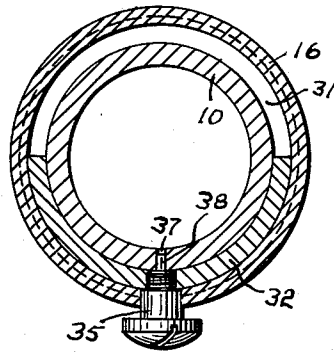

Fig. 8.

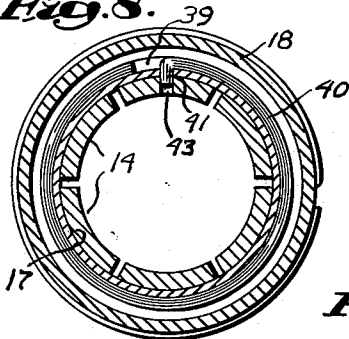
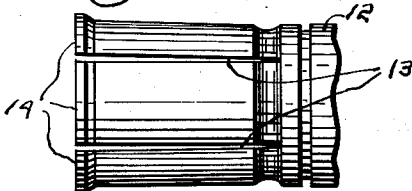

Fig. 7.



Fig. 9



Inventor:
Robert G. Hare,
by *Abel Spear,*
Attorney

1

2,989,815

AUTOMATIC CHOKE DEVICE FOR SHOTGUNS
 Robert G. Hare, Sharon, Mass., assignor to Hartford Gun
 Choke Company, Inc., Newington, Conn., a corporation
 of Connecticut

Filed Aug. 15, 1957, Ser. No. 678,373

12 Claims. (Cl. 42-79)

This invention relates to choke devices to be attached to the muzzles of single barrel shot guns of the semi-automatic, pump, bolt-action or other multi-shot types, and this application is a continuation in part of my co-pending application, Serial No. 617,307, filed October 22, 1956, and now abandoned.

With shot guns of those types, the shooter has a problem as to whether to select one whose barrel is a cylinder, improved cylinder, modified choke or full choke for, no matter which barrel is selected, that selection results in real limitations in use. The recognition of this factor has resulted in the development of adjustable choke devices which enable the shooter to select the setting best suited for the game he is hunting.

These devices have been well accepted even though shot guns equipped with them do not have the advantage afforded by double barrel shot guns that the second shot is subject to a greater choking effect than the first shot. It is the principal objective of this invention to provide choke devices in which second and subsequent shots are automatically subjected to a greater choking effect than that initially afforded by the selected setting.

This objective is important for two reasons. The first of these is that, in shooting small game, the first shot is usually at a closer range than the second shot and hence requires a more open shot pattern than is desirable at the longer range of the second shot.

The second reason is that it is a common characteristic of a shot gun that it will pattern well with one size of shot at one particular choke, while another size of shot may require slightly more or less choking to produce a good pattern.

That objective is attained by providing a choke device having a tubular element attached at one end to the muzzle of the shot gun barrel and, at its other end, being provided with forwardly disposed, resilient choke fingers having forwardly and outwardly inclined portions. The device also includes a unit axially slidable on the element for movement forwardly relative thereto from a yieldably maintained first position, in automatic response to the forces attendant the firing of a shell, into a second position in which it is locked, until manually released, by means associated with the element which may be gas or mechanically operated, or combinations thereof. The unit has forwardly and inwardly inclined internal portions, and in its second position, the radial spacing of the fingers of the element is decreased to a desired extent.

To provide adjustability, the unit is provided with a first sleeve receiving the element and a second sleeve threaded to the first sleeve and formed with the above mentioned internal inclined portions. By this construction, the unit may be lengthened or shortened by turning the second sleeve relative to the first sleeve, thereby varying the axial location of its internal inclined portion. The operating connection between the unit and the choke fingers is a split ring encircling the choke fingers backed by the first sleeve and movable with it and in engagement with the second sleeve. As a consequence, movement of the internal inclined portion of the unit effects a variation in the radial spacing of the choke fingers on axial movement of the unit relative thereto in response to the firing of a shell, and also on the turn-

2

ing of the second sleeve relative to the first sleeve in the making of adjustments of the device.

This last named feature of the invention is of particular advantage as it enables a wide range of adjustments to be made as may be required to produce proper patterns for any type of shot gun shooting. That is to say, not only may settings be established for the normal range of choke effects, but also intermediate settings are provided to take care of the variables inherent in shot sizes and loads.

A gun equipped with a choke device in accordance with the invention is adapted to provide the choke combinations of a plurality of double-barrel shot guns in the normal settings, as well as additional combinations in the intermediate settings. In addition, the device may be locked in any setting for continuous use with that to be equal to a corresponding number of single barrel shot guns with a predetermined choke effect.

Other objectives of the invention include gas operated means that may be employed to provide a lock for the unit in its first position and various features of the ring, fingers and unit that ensure ease and accuracy of adjustments and reliability in use.

In the accompanying drawings, there is shown an illustrative embodiment of the invention from which these and other of its objectives, novel features and advantages will be readily apparent.

In the drawings:

FIG. 1 is a longitudinal section of a choke device, in accordance with the invention, taken along the indicated lines 1-1 of FIG. 7;

FIG. 2 is a similar view showing the relation of the parts after a shot has been fired;

FIG. 3 is a section taken along the indicated lines 3-3 of FIG. 1;

FIG. 4 is a section taken along the indicated lines 4-4 of FIG. 2;

FIG. 5 is a schematic view illustrating the cross-sectional shape of the split ring relative to the surfaces of the element and the second sleeve;

FIG. 6 is a view, generally similar to FIG. 3, illustrating another embodiment of the invention;

FIG. 7 is a side elevation of a choke device, in accordance with the invention;

FIG. 8 is a section taken along the indicated lines 8-8 of FIG. 1; and

FIG. 9 is a fragmentary elevation of the fingers of the element.

In the embodiment of the invention shown in the drawings, a tubular element 10 is threaded onto the muzzle of the shot gun barrel 11. The element 10 includes a front portion, generally indicated at 12, whose outside diameter is reduced and whose inside diameter is approximately equal to that of the barrel 11. The portion 12 has a plurality of circumferentially spaced, longitudinally disposed, open-sided slots 13 establishing forwardly disposed, resilient choke fingers 14 of arcuate cross section.

A unit, generally indicated at 15, includes a first sleeve 16 dimensioned to slidably receive and be supported by the element 10 and is provided with a front part 17 of reduced outside diameter to which the rear end of a second sleeve 18 is threaded as at 19. The unit 15 also has a stop 20 threaded as at 21 into the rear end of the first sleeve 16. The stop 20 engages one end of a compression spring 22 which is housed within the rear part of the sleeve 16 and has its other end resiliently bearing against the rear end of the element 10. A front sight 23 is shown as threaded into the first sleeve 16.

By these means, the unit 15 is yieldably held in a rearward first position, illustrated by FIG. 1, but is moved forwardly in response to at least one of the forces at-

tendant the firing of a shell, such as recoil, gas pressure, or both, into a second position, illustrated by FIG. 2. In the embodiment of the invention shown in the drawings, the front end 24 of the second sleeve 18 is provided with series of slots 25 disposed at right angles to the bore of the barrel thus to establish a muzzle brake so that gas pressure may be utilized with double advantage.

In order that movement of unit 15 from its first to its second position on the discharge of the shot gun may be attended by a constriction of the choke fingers 14 to affect the pattern of the second and subsequent shots, a split ring 26 is provided. This ring encircles the fingers 14 and is normally in engagement with the front end of the front part 17 of the first sleeve 16 thus to move forwardly therewith and it is also in engagement with the forwardly and inwardly tapering portion 27 of the second sleeve 18. Forward movement of the unit 15 is thus operative to drive the split finger ring 26 forwardly along the resilient fingers 14 and into constricting engagement with the forwardly and outwardly tapering shoulders 28 at their ends. A taper in the order of 30° has proved satisfactory. Attention is directed to FIG. 9, from which it will be apparent that the fingers 14 of the element 10 are slightly expanded so that their outer surfaces are slightly forwardly and outwardly inclined thereby to ensure that the diameter of the device is constant in the zone of and forwardly of the portion 17 of the first sleeve 16.

In practice, the outer surface of the ring 26 is forwardly inwardly tapered and, as will be apparent from FIG. 5, its taper approximates, but is slightly less than that of the portion 27 of the second sleeve 18. The ring 26 has annular flat bearing portions 29 and 30 at its rear outer and forward inner ends, respectively. The ring 26, as shown in FIG. 5, has an internal series of channels 26^a extending from end-to-end thereof and serving as gas vents.

It will be noted that the radial spacing of the fingers 14 may be affected by turning the second sleeve 18 relative to the first sleeve 16 as well as by lengthwise movement of unit 15 in response to the firing of a shot.

In order that the constriction of the fingers 14 resulting from the firing of the first shot may be maintained while any subsequent shot is fired, the tubular element 10 is shown as formed with an annular recess 31. Within the recess 31, there is an arcuate lock member 32 normally confined against outward movement in response to the spring 33 by the closely fitting sleeve 16 which is provided with an annular recess 34 located rearwardly of the recess 31. When the unit 15 is driven forwardly into its second position, the recess 34 registers with the recess 31, as will be apparent from FIG. 2, enabling the lock member 32 to be partially unseated and to enter it to lock the unit 15 against movement rearwardly towards its first position. Return of the unit 15 to its first position results when the release pin 35, slidably confined in the longitudinal slot 36 of the first sleeve 16 and threaded into the lock member 32, is pushed against the action of the spring 33 to unseat the lock member 32 from the recess 34. The spring 22 is then operative to restore the unit 15 to its first position.

The choke device may also be locked in its second position by other means. For example, as shown in FIG. 6, the recess 31 may have a gas port 37 in communication with the interior of the element 10 slidably receiving the pin 38 carried by the lock member 32 so that it may be operated in response to gas pressures when a shell is fired.

In addition to means for locking the unit 15 in its second position, means may be employed to lock it in its first position to ensure that the firing of the first shot cannot so prematurely move the unit as to affect the setting selected for that first shot. For that purpose, there is provided an annular groove 39 in the front part of the first sleeve 16 for a spring 40 having an end 41

extending through a radial bore 42 that, in the first position of the unit 15, registers with a bore 43 through one of the fingers 14. By this arrangement, the unit 15 is locked to the element 10 until gas pressure unseats the spring end 41, and to permit such unseating, the second sleeve 18 has an annular chamber 44 overlying the spring 40. When the unit 15 is returned to its first position, the spring end 41 again enters the bore 43.

It will be apparent that the action of the choke device may be widely varied, as by varying the tensioning of the spring 22 by turning the stop 20 in one direction or the other relative to the sleeve 16. Adjustments are primarily affected, however, by turning the second sleeve 18 in one direction or the other relative to the first sleeve 16 so that the fingers 14 may be set to ensure the desired pattern for the first shot. In practice, the sleeve 18 bears suitable indicia, as shown in FIG. 7, to enable a desired range of normal and intermediate settings to be easily established. Such settings are maintained by providing the front part 17 of the first sleeve 16 with a series of detent grooves 45 spaced about its periphery. The second sleeve 18 is shown as having an annular groove for the spring 46 having an end 47 extending therethrough into resilient engagement with the front part 17 so that as the sleeve 18 is turned relative to the sleeve 16, the spring end 47 yieldably catches in first one and then another of the detent grooves 45.

It will be appreciated that with the wide range of combinations of choke effects possible, a shot gun equipped with a choke device in accordance with the invention can be quickly and easily adapted to any existing requirements for most effective use as any setting selected for the first shot is automatically followed by the next more constrictive setting for subsequent shots. In addition, the device may be set by manually extending the unit 15 forwardly into its second position and adjusting the second sleeve 18 to the desired choke setting, so that all shots are at any one setting. The shot gun to which the device is attached is thus capable of serving with all shots continuing at a selected one of the four major settings, open, improved, modified, full choke, or at a selected one of the three intermediate positions, thus to be the equivalent of seven single barrel guns. The usual range of combinations for automatic choke changes is open to improved, improved to modified, and modified to full, so that the choke device also makes the shot gun to which it is attached the equivalent of three double-barrelled shot guns and the equivalent of one additional shot gun for each of the two intermediate settings provided, thus to make it the equivalent of five double-barrelled guns.

What I therefore claim and desire to secure by Letters Patent is:

1. In a shot gun choke device, a tubular element attachable at one end to the muzzle of a shot gun barrel and including at the other end forwardly disposed, resilient choke fingers provided with forwardly and outwardly tapering portions, a unit slidably connected to said element for axial movement forwardly from a first position to a second position in response to the firing of a shell and including first and second sleeves, means yieldably urging said unit rearwardly towards said first position, the interior of said second sleeve including a forwardly and inwardly tapering portion, said second sleeve being threaded to said first sleeve to enable the position of the tapering portion of said second sleeve to be axially varied, a connection between said unit and said element holding said unit in said first position until a shell is fired and actuated from within said tubular element, a split ring backed by said first sleeve and in engagement with said tapering portions of said second sleeve and said fingers whereby the radial spacing of said fingers is reduced on movement of said unit into said second position both on the turning of said second sleeve relative to said first sleeve to shorten said unit and on the forward move-

5

ment of said unit on the firing of a shell, and a lock between said element and said unit operative when said unit is in said second position.

2. In a shot gun choke device, a tubular element attachable at one end to the muzzle of a shot gun barrel and including at the other end forwardly disposed, resilient choke fingers provided with forwardly and outwardly tapering portions, a unit slidably connected to said element for axial movement forwardly from a first position to a second position in response to the firing of a shell and including first and second sleeves, means yieldably urging said unit rearwardly towards said first position, the interior of said second sleeve including a forwardly and inwardly tapering portion, said second sleeve being threaded to said first sleeve to enable the position of the tapering portion of said second sleeve to be axially varied, a resilient connection between said unit and said element yieldably holding said unit in said first position and releasable from within said tubular element, a split ring backed by said first sleeve and in engagement with said tapering portions of said second sleeve and said fingers whereby the radial spacing of said fingers is reduced on movement of said unit into said second position both on the turning of said second sleeve relative to said first sleeve to shorten said unit and on the forward movement of said unit on the firing of a shell, and a lock between said element and said unit operative when said unit is in said second position.

3. In a shot gun choke device, a tubular element attachable at one end to the muzzle of a shot gun barrel and including at the other end forwardly disposed, resilient choke fingers provided with forwardly and outwardly tapering portions, a unit slidably connected to said element for axial movement forwardly from a first position to a second position in response to the firing of a shell and including first and second sleeves, means yieldably urging said unit rearwardly towards said first position, the interior of said second sleeve including a forwardly and inwardly tapering portion, said second sleeve being threaded to said first sleeve to enable the position of the tapering portion of said second sleeve to be axially varied, a gas operated release normally connecting said unit and said element in said first position, a split ring backed by said first sleeve and in engagement with said tapering portions of said second sleeve and said fingers whereby the radial spacing of said fingers is reduced on movement of said unit into said second position both on the turning of said second sleeve relative to said first sleeve to shorten said unit and on the forward movement of said unit on the firing of a shell, and a lock between said element and said unit operative when said unit is in said second position.

4. In a shot gun choke device, a tubular element attachable at one end to the muzzle of a shot gun barrel and including at the other end forwardly disposed, resilient choke fingers provided with forwardly and outwardly tapering portions, a unit slidably connected to said element for axial movement forwardly from a first position to a second position in response to the firing of a shell and including first and second sleeves, means yieldably urging said unit rearwardly towards said first position, the interior of said second sleeve including a forwardly and inwardly tapering portion, said second sleeve being threaded to said first sleeve to enable the position of the tapering portion of said second sleeve to be axially varied, a resilient connection between said unit and said element yieldably holding said unit in said first position and releasably exposed relative to the interior of said tubular element, a split ring backed by said first sleeve and in engagement with said tapering portions of said second sleeve and said fingers whereby the radial spacing of said fingers is reduced on movement of said unit into said second position both on the turning of said second sleeve relative to said first sleeve to shorten said unit and on the forward movement of said unit on the firing of a

6

shell, and a lock between said element and said unit operative when said unit is in said second position, said lock being spring operated and including a manually operated, inwardly pushable release.

5. In a shot gun choke device, a tubular element attachable at one end to the muzzle of a shot gun barrel and including at the other end forwardly disposed, resilient choke fingers provided with forwardly and outwardly tapering portions, a unit slidably connected to said element for axial movement forwardly from a first position to a second position in response to the firing of a shell and including first and second sleeves, means yieldably urging said unit rearwardly towards said first position, the interior of said second sleeve including a forwardly and inwardly tapering portion, said second sleeve being threaded to said first sleeve to enable the position of the tapering portion of said second sleeve to be axially varied, a resilient connection between said unit and said element yieldably holding said unit in said first position and releasably exposed relative to the interior of said tubular element, a split ring backed by said first sleeve and in engagement with said tapering portions of said second sleeve and said fingers whereby the radial spacing of said fingers is reduced on movement of said unit into said second position both on the turning of said second sleeve relative to said first sleeve to shorten said unit and on the forward movement of said unit on the firing of a shell, and a lock between said element and said unit operative when said unit is in said second position, said lock being gas operated and including a manually operated release.

6. In a shot gun choke device, a tubular element attachable at one end to the muzzle of a shot gun barrel and including at the other end forwardly disposed, resilient choke fingers provided with forwardly and outwardly tapering portions, a unit slidably connected to said element for axial movement forwardly from a first position to a second position in response to the firing of a shell and including first and second sleeves, means yieldably urging said unit rearwardly towards said first position, the interior of said second sleeve including a forwardly and inwardly tapering portion, said second sleeve being threaded to said first sleeve to enable the position of the tapering portion of said second sleeve to be axially varied, a resilient connection between said unit and said element yieldably holding said unit in said first position and releasably exposed relative to the interior of said tubular element, a split ring externally tapered at an angle slightly less than that of said second sleeve portion backed by said first sleeve and including an internal annular bearing at its front end in engagement with said tapering portions of said second sleeve and said fingers whereby the radial spacing of said fingers is reduced on movement of said unit into said second position both on the turning of said second sleeve relative to said first sleeve to shorten said unit and on the forward movement of said unit on the firing of a shell, and a lock between said element and said unit operative when said unit is in said second position.

7. In a shot gun choke device, a tubular element attachable at one end to the muzzle of a shot gun barrel and including at the other end forwardly disposed, outwardly flaring, resilient choke fingers provided with forwardly and outwardly tapering terminal portions, a unit slidably connected to said element for axial movement forwardly from a first position to a second position in response to the firing of a shell and including first and second sleeves, means yieldably urging said unit rearwardly towards said first position, the interior of said second sleeve including a forwardly and inwardly tapering portion, said second sleeve being threaded to said first sleeve to enable the position of the tapering portion of said second sleeve to be axially varied, a resilient connection between said unit and said element yieldably holding said unit in said first position and releasably ex-

posed relative to the interior of said tubular element, a split ring backed by said first sleeve and in engagement with said tapering second sleeve portion and with said fingers whereby the radial spacing of said fingers is reduced on movement of said unit into said second position both on the turning of said second sleeve relative to said first sleeve to shorten said unit and on the forward movement of said unit on the firing of a shell, and a lock between said element and said unit operative when said unit is in said second position.

8. In a shot gun choke device, a tubular element attachable at one end to the muzzle of the shot gun barrel and including at the other end forwardly disposed, resilient choke fingers provided with forwardly and outwardly tapering portions, a unit slidably connected to said element for axial movement forwardly from a first position to a second position in response to the firing of a shell and including first and second sleeves, means yieldably urging said unit rearwardly towards said first position, the interior of said second sleeve including a forwardly and inwardly tapering portion, said second sleeve being threaded to said first sleeve to enable the position of the tapering portion of said second sleeve to be axially varied, a resilient connection between said unit and said element yieldably holding said unit in said first position and releasably exposed relative to the interior of said tubular element, a split ring having vents extending from end-to-end thereof and backed by said first sleeve and in engagement with said tapering portions of said second sleeve and said fingers whereby the radial spacing of said fingers is reduced on movement of said unit into said second position both on the turning of said second sleeve relative to said first sleeve to shorten said unit and on the forward movement of said unit on the firing of a shell, and a lock between said element and said unit operative when said unit is in said second position.

9. In a shot gun choke device, a tubular element attachable at one end to the muzzle of a shot gun barrel and including at the other end forwardly disposed, resilient choke fingers provided with forwardly and outwardly tapering portions and an intermediate annular groove, a unit slidably connected to said element for axial movement forwardly from a first position to a second position in response to the firing of a shell and including a first sleeve having an annular groove registering with said element groove in said second position and a second sleeve, the interior of which has a forwardly and inwardly tapering portion, said second sleeve being threaded to said first sleeve to enable the position of the tapering portion of said second sleeve to be axially varied, a resilient connection between said unit and said element yieldably holding said unit in said first position, means yieldably urging said unit rearwardly towards said first position, a split ring backed by said first sleeve and in engagement with said tapering portions of said second sleeve and said fingers whereby the radial spacing of said fingers is reduced on movement of said unit into said second position both on the turning of said second sleeve relative to said first sleeve to shorten said unit and on the forward movement of said unit on the firing of a shell, a lock slidable relative to said first sleeve and including an exposed manually engageable release and seated in the annular groove of the element, and means operative when said unit is in said second position to force said lock into said sleeve groove.

10. In a shot gun choke device, a tubular element attachable at one end to the muzzle of a shot gun barrel and including at the other end forwardly disposed, resilient choke fingers provided with forwardly and outwardly tapering portions and a port, a unit slidably connected to said element for axial movement forwardly from a first position to a second position in response to the firing of a shell and including a first sleeve having a port aligned with said finger port in said first posi-

tion and a second sleeve which has a forwardly and inwardly tapering portion, means yieldably urging said unit rearwardly towards said first position, said second sleeve being threaded to said first sleeve to enable the position of the tapering portion of said second sleeve to be axially varied, a piston resiliently connected to said first sleeve and extending as a gas operated lock into said alined ports, a split ring backed by said first sleeve and in engagement with said tapering portions of said second sleeve and said fingers whereby the radial spacing of said fingers is reduced on movement of said unit into said second position both on the turning of said second sleeve relative to said first sleeve to shorten said unit and on the forward movement of said unit on the firing of a shell, and a lock between said element and said unit operative when said unit is in said second position.

11. In a shot gun choke device, a tubular element attachable at one end to the muzzle of a shot gun barrel and including at the other end forwardly disposed, resilient choke fingers provided with forwardly and outwardly tapering portions, a unit slidably connected to said element for axial movement forwardly from a first position to a second position in response to the firing of a shell and including first and second sleeves, means yieldably urging said unit rearwardly into said first position, the interior of said second sleeve including a forwardly and inwardly tapering portion, said second sleeve being threaded to said first sleeve to enable the position of the tapering portion of the second sleeve to be axially varied, a connection between said unit and said element holding said unit in said first position until a shell is fired, means in engagement with said tapering portions of said second sleeve and said fingers whereby the radial spacing of said fingers is reduced on movement of said unit into said second position both on the turning of said second sleeve relative to said first sleeve to shorten said unit and on the forward movement of said unit on the firing of a shell, and a lock between said element and said unit operative when said unit is in said second position.

12. In a shot gun choke device, a tubular element attachable at one end to the muzzle of a shot gun barrel and including at the other end forwardly disposed, resilient choke fingers provided with forwardly and outwardly tapering portions, a unit slidably connected to said element for axial movement forwardly from a first position to a second position in response to the firing of a shell and including first and second sleeves, means yieldably urging said unit rearwardly into said first position, the interior of said second sleeve including a forwardly and inwardly tapering portion, said second sleeve being threaded to said first sleeve to enable the position of the tapering portion of said second sleeve to be axially varied, a resilient connection between said unit and said element yieldably holding said unit in said first position, means in engagement with said tapering portions of said second sleeve and said fingers whereby the radial spacing of said fingers is reduced on movement of said unit into said second position both on the turning of said second sleeve relative to said first sleeve to shorten said unit and on the forward movement of said unit on the firing of a shell, and a lock between said element and said unit operative when said unit is in said second position.

References Cited in the file of this patent

UNITED STATES PATENTS

| | | |
|-----------|------------|---------------|
| 2,134,238 | Sedberry | Oct. 25, 1938 |
| 2,270,592 | Kitzmiller | Jan. 20, 1942 |
| 2,417,721 | Whedon | Mar. 18, 1947 |
| 2,558,200 | Schmeling | June 26, 1951 |
| 2,676,429 | Gotterson | Apr. 27, 1954 |
| 2,759,286 | Moore | Aug. 21, 1956 |
| 2,765,564 | Schroeder | Oct. 9, 1956 |
| 2,883,782 | Schroeder | Apr. 28, 1959 |
| 2,894,349 | Hare | July 14, 1959 |