



- (51) International Patent Classification:
A61B 1/31 (2006.01)
- (21) International Application Number:
PCT/IB2012/000953
- (22) International Filing Date:
1 February 2012 (01.02.2012)
- (25) Filing Language: English
- (26) Publication Language: English
- (30) Priority Data:
61/439,197 3 February 2011 (03.02.2011) US
- (71) Applicant (for all designated States except US): GIVEN IMAGING LTD. [—/IL]; 2 Hacarmel St., New Industrial Park, P.O. Box 258, Yoqneam 20692 (IL).
- (72) Inventor; and
- (75) Inventor/Applicant (for US only): IDAN, Gavriel, J. [IL/IL]; 44A Einstein Street, Haifa 34602 (IL).
- (81) Designated States (unless otherwise indicated, for every kind of national protection available): AE, AG, AL, AM, AO, AT, AU, AZ, BA, BB, BG, BH, BR, BW, BY, BZ,

CA, CH, CL, CN, CO, CR, CU, CZ, DE, DK, DM, DO, DZ, EC, EE, EG, ES, FI, GB, GD, GE, GH, GM, GT, HN, HR, HU, ID, IL, IN, IS, JP, KE, KG, KM, KN, KP, KR, KZ, LA, LC, LK, LR, LS, LT, LU, LY, MA, MD, ME, MG, MK, MN, MW, MX, MY, MZ, NA, NG, NI, NO, NZ, OM, PE, PG, PH, PL, PT, QA, RO, RS, RU, RW, SC, SD, SE, SG, SK, SL, SM, ST, SV, SY, TH, TJ, TM, TN, TR, TT, TZ, UA, UG, US, UZ, VC, VN, ZA, ZM, ZW.

(84) Designated States (unless otherwise indicated, for every kind of regional protection available): ARIPO (BW, GH, GM, KE, LR, LS, MW, MZ, NA, RW, SD, SL, SZ, TZ, UG, ZM, ZW), Eurasian (AM, AZ, BY, KG, KZ, MD, RU, TJ, TM), European (AL, AT, BE, BG, CH, CY, CZ, DE, DK, EE, ES, FI, FR, GB, GR, HR, HU, IE, IS, IT, LT, LU, LV, MC, MK, MT, NL, NO, PL, PT, RO, RS, SE, SI, SK, SM, TR), OAPI (BF, BJ, CF, CG, CI, CM, GA, GN, GQ, GW, ML, MR, NE, SN, TD, TG).

Published:
— without international search report and to be republished upon receipt of that report (Rule 48.2(g))



WO 2012/104733 A2

(54) Title: SYSTEM AND METHOD FOR DETERMINING LOCATION AND ORIENTATION OF A DEVICE IN-VIVO

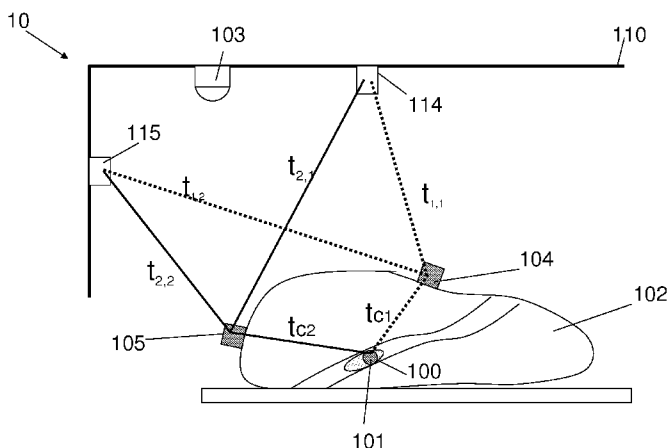

FIG. 1

(57) Abstract: A system and method for determining location and orientation of an in-vivo device, with respect to an external system in which the device is located include a frame with external magnets attached thereon. An in-vivo device is inserted into the patient's body, which is placed within the system, and the external magnets apply magnetic forces on the in-vivo device. A radio beacon transmitter is attached to the frame for transmitting a radio pulse. The in-vivo device includes an ultrasonic transmitter for transmitting an ultrasonic signal, which is triggered by the radio pulse. At least three transponders are placed on the patient's body, each transponder sending a first acoustic signal triggered by the radio pulse, and each sending a second acoustic signal triggered by the device's ultrasonic signal. At least three sonic detectors are located on the frame for detecting each of the transponders' first and second sonic signals, and a processor measures time of detection of the transponders' signals and thus calculates location of the device in frame coordinates, and in body coordinates.

SYSTEM AND METHOD FOR DETERMINING LOCATION AND ORIENTATION OF A DEVICE IN-VIVO

TECHNICAL FIELD

[001] The field of determining location of an in-vivo device, and more specifically to determining the in-vivo location and orientation of an in-vivo device, as well as its location and orientation with respect to an external system in which the device is located.

BACKGROUND OF THE INVENTION

[002] Swallowable capsule endoscopes are well-known devices that are used in order to acquire images of in-vivo lumens, e.g., the gastrointestinal (GI) tract. Nowadays, there is an on going need for adding maneuvering capabilities to such capsules and to other in-vivo devices, and thus have the ability to perform various in-vivo operations at specific locations along the lumen that such devices travel along. One method of maneuvering an in-vivo device while in-vivo, is to use external magnetic fields, which may surround the patient being treated by the in-vivo device, and may control the location of the in-vivo device.

[003] The external magnetic fields may also assist in determining location and orientation of the in-vivo device along in-vivo lumens. In order to determine the location and orientation of the device, e.g., a capsule endoscope device, the device may include sensing coils to sense the magnetic fields. The location and orientation of the device may then be calculated based on the strength of the sensed fields. However, such a method requires complex processing to be done inside the in-vivo device. Furthermore, determining location and orientation based on the external magnetic fields, as well as maneuvering the device using the same magnetic fields may create an overload on the external magnetic system.

[004] Therefore, there is a need for a different system and method for determining location (and orientation) of an in-vivo device, e.g., a swallowable capsule, that is not dependent on the same magnetic forces that are used to maneuver the device in-vivo.

SUMMARY

[005] The present invention provides systems and methods for determining location and orientation of an in-vivo device, which is located within an external system applying magnetic fields on the device. In one example, the in-vivo device may be a capsule endoscope imaging as it moves along the GI tract. In other examples, the in-vivo device may be a catheter, an endoscope or any other in-vivo device that may be magnetically maneuvered within a patient's body.

BRIEF DESCRIPTION OF THE DRAWINGS

[006] The above and other objects and advantages of the invention will be apparent upon consideration of the following detailed description, taken in conjunction with the accompanying drawings, in which the reference characters refer to like parts throughout and in which:

[007] **Fig. 1** illustrates a schematic two-dimensional system for determining location of an in-vivo device, in accordance with one embodiment of the present invention;

[008] **Figs. 2A-2B** illustrate schematic timing diagrams, in accordance with an embodiment of the present invention;

[009] **Fig. 3** illustrates a schematic timing connection system, in accordance with an embodiment of the present invention;

[0010] **Fig. 4** illustrates a schematic system assisting in calculations of location of an in-vivo device, in accordance with an embodiment of the present invention;

[0011] **Fig. 5** illustrates a schematic system assisting in calculations of location of an in-vivo device, in accordance with an embodiment of the present invention;

[0012] **Fig. 6** illustrates a schematic system assisting in calculations of location of an in-vivo device, in accordance with an embodiment of the present invention;

[0013] **Fig. 7** illustrates a schematic two-dimensional system for determining location and orientation of an in-vivo device, in accordance with one embodiment of the present invention;

[0014] **Fig. 8** illustrates a method for determining location of an in-vivo device, in accordance with one embodiment of the present invention;

[0015] **Fig. 9** illustrates a schematic two-dimensional system for determining location of an in-vivo device, in accordance with another embodiment of the present invention;

[0016] **Figs. 10A-10B** illustrate schematic distance estimation between an in-vivo device and a component of the system based on time, in accordance with an embodiment of the present invention;

[0017] **Figs. 11A-11B** illustrate schematic orientation estimations of an in-vivo device based on reflected pulse shape, in accordance with an embodiment of the present invention;

[0018] **Figs. 12A-12B** illustrate schematic reflection patterns on the in-vivo device, in accordance with an embodiment of the present invention; and

[0019] **Figs. 13A-13D** illustrate a schematic modulation pattern on the housing of the in-vivo device, and captured reflected signals indicating roll angle, in accordance with an embodiment of the present invention.

[0020] It will be appreciated that for simplicity and clarity of illustration, elements shown in the figures have not necessarily been drawn to scale. For example, the dimensions of some elements may be exaggerated relative to other elements for clarity. Further, where considered appropriate, reference numerals may be repeated among the figures to indicate corresponding or analogous elements.

DETAILED DESCRIPTION OF THE INVENTION

[0021] In the following detailed description, numerous specific details are set forth in order to provide a thorough understanding of the invention. However, it will be understood by those skilled in the art that the present invention may be practiced without these specific details. In other instances, well-known methods, procedures, and components have not been described in detail so as not to obscure the present invention.

[0022] The in-vivo systems and methods described below provide examples of determining location and orientation of in-vivo devices, with respect to the coordinates of the patient's body that the devices are inserted into, and with respect to the coordinates of an external system in which the in-vivo device is located.

[0023] Reference is now made to **Fig. 1**, which illustrates a schematic two-dimensional system **10** for determining location of an in-vivo device, in accordance with

an embodiment of the present invention. According to some embodiments, an in-vivo imaging device, e.g., a capsule endoscope **100** may be inserted into a patient's body **102**. In some embodiments, the device or capsule **100** may be inserted into the patient **102** through swallowing, ingestion, or it may be inserted into the patient **102** with the assistance of a delivery device. Patient **102** may be placed within a machine frame **110**, which may comprise external magnets (not shown) that may be used to maneuver the device **100** by applying magnetic forces on it. In some embodiments, device **100** may comprise an internal magnet, which the external magnets may apply magnetic forces on. In some embodiments, the device **100** may be inserted into the body of the patient **102** before the patient **102** is placed within the machine frame. In other embodiments, the device **100** may be inserted into the patient **102** after the patient is positioned within the frame **110** comprising the external magnets.

[0024] In some embodiments, device **100** may comprise an ultrasonic transmitter **101** for transmitting an ultrasonic signal. Ultrasonic transmitter **101** may comprise a small piezoelectric element, such that it may transmit ultrasonic signals to any direction, e.g., ultrasonic transmitter **101** may transmit signals omni-directionally. According to some embodiments, the intensity of the ultrasonic signals transmitted by ultrasonic transmitter **101** is less important than the importance of the signal reaching all directions at substantially the same time. The intensity of the signal should, however, be high enough to enable its detection.

[0025] Device **100** may comprise an imaging system, which may comprise an optical system and an imager for acquiring images of the lumen that device **100** passes through. Device **100** may further comprise a transmitter for transmitting the in-vivo acquired images to an external receiver. The acquired images may be displayed on a monitor or screen for the convenience of the operator of the machine frame **110** and the device **100**. The images may be displayed in real time, so as to enable the operator of the device **100** to maneuver device **100** according to the acquired images. For example, the operator may determine in-vivo location of device **100** according to real time displayed images, and may then decide on a new location towards which to maneuver the imaging device **100**. Device **100** may comprise an internal power source, such as one or more batteries. Yet, in other embodiments, device **100** may only comprise a capacitor that may be supplied with

electrical power by an external powering device. In some embodiments, the external magnets may be used to energize device **100**.

[0026] Device **100** may comprise various tools for performing operations at specific locations along the lumen. For example, device **100** may comprise a chamber into which a biopsy, or sample of in-vivo tissue may be inserted, after being sucked and cut by a blade or any other cutting element that device **100** may further comprise. In some embodiments, the sample may be a fluid sample of in-vivo fluid. Device **100** may comprise an imager for acquiring images of the lumen it passes along, as well as acquiring images of the chamber. In other embodiments, device **100** may comprise separate imagers; one for imaging the in-vivo lumen and one for imaging the chamber. In some embodiments, the device **100** may comprise a medicament that may be injected or released from device **100** at a target location along the lumen.

[0027] According to some embodiments, machine frame **110** may comprise a radio beacon transmitter **103** that may transmit a radio pulse. The machine frame **110** may further comprise at least two sonic detectors **114** and **115**. According to some embodiments, at least two transponders **104** and **105** may be placed or attached onto the patient's body **102**.

[0028] In some embodiments, radio beacon transmitter **103** may transmit a radio pulse that may trigger transmission of signals of other components in system **10**. The radio signal sent by radio beacon **103** may reach all of the components of system **10** at substantially the same time, thus causing a reaction of signals that have the same start time. According to some embodiments, ultrasonic transmitter **101** in device **100** may be triggered by the radio pulse sent by radio beacon **103**. Thus, ultrasonic transmitter **101** may send an ultrasonic signal.

[0029] Once radio beacon **103** sends a radio pulse, each of the two transponders **104** and **105** may be triggered to send a first acoustic signal. Each of transponders **104** and **105** may send a second acoustic signal, once triggered by the ultrasonic signal that may be sent by ultrasonic transmitter **101** present in device **100**. The sonic detectors **114** and **115** may detect the first and second acoustic signals that may be transmitted by each of transponders **104** and **105**.

[0030] As shown in **Fig. 1**, the ultrasonic signal that may be sent by ultrasonic transmitter **101** may be detected by transponder **104** at time t_{c1} . The same ultrasonic signal sent by device **100** may be detected by transponder **105** at time t_{c2} . As shown in **Fig. 1**, the second acoustic signal that may be sent by transponder **104** in response to the ultrasonic signal transmitted by device **100**, may be detected by sonic detector **114** at time $t_{1,1}$, whereas that same second acoustic signal may be detected by sonic detector **115** at time $t_{1,2}$. The second acoustic signal that may be sent by transponder **105** in response to the ultrasonic signal transmitted by device **100**, may be detected by sonic detector **115** at time $t_{2,2}$, whereas it may be detected by sonic detector **114** at time $t_{2,1}$.

[0031] According to some embodiments, in order to prevent the radio pulse transmitted by radio beacon transmitter **103**, from triggering operation of other devices that may be located nearby the radio beacon **103** or the machine frame **110**, the radio pulse may have a wave form that is more complex than a standard pulse. In order for the components of system **10**, e.g., transponders **104** and **105**, device **100** and sonic detectors **114** and **115**, to detect the unique radio pulse (and in response some components may transmit their own signal), such components may comprise an encoder that may recognize the specific radio pulse sent by radio beacon **103**.

[0032] According to some embodiments, each of the transponders **104** and **105** may comprise a power supply and a radio receiver for receiving the radio pulse sent by radio beacon transmitter **103**. Each of the transponders may further comprise an ultrasonic receiver for receiving an ultrasonic signal from device **100**, and a transmitter for transmitting a first acoustic signal in response to the radio pulse and for transmitting a second acoustic signal in response to the ultrasonic signal.

[0033] In some embodiments, transponder **104** may transmit acoustic signals at a different frequency than the frequency of signals transmitted by transponder **105**. The different signals' frequency of the at least two transponders may enable distinction between the origin of an acoustic signal detected by sonic detectors **114** and **115**. That is, the different frequency of acoustic signals detected by sonic detectors **114** and **115** may enable a processor to determine whether a detected signal was transmitted by transponder **104** or whether it was transmitted by transponder **105**. In other embodiments, each of the transponders **104** and **105** may transmit an acoustic signal comprising a different specific

sound. In yet other embodiments, the acoustic signals transmitted by either of the transponders **104** and **105** may comprise a different code that may ease on distinguishing between the origins of detected acoustic signals. In some embodiments, distinction between the transponders **104** and **105** may be done by time multiplexing.

[0034] Reference is now made to **Figs. 2A-2B**, which illustrate schematic timing diagrams, in accordance with an embodiment of the present invention. **Fig. 2A** illustrates an example of a timing diagram with respect to sonic detector **114**. The diagram in **Fig. 2A** illustrates the signal density over time per all signals detected by sonic detector **114**. For example, the first signal detected by detector **114** may be a signal detected at time $t_{1,1}$ and sent by transponder **104**. This signal may have been triggered by the radio pulse transmitted by radio beacon **103**, e.g., the signal detected at time $t_{1,1}$ may be the first acoustic signal sent by transponder **104**. The second signal that may be detected by detector **114** may have been detected at time $t_{2,1}$. This second signal detected by detector **114** may be the first acoustic signal sent by transponder **105**, which may have been triggered by the radio pulse transmitted by radio beacon **103**. The third signal that may be detected by detector **114** may be detected at time $t_{1,1}+t_{c1}$. That is, the third detected signal may be one initiated by device **100**, and which triggered transponder **104** to send a second acoustic signal. The fourth signal detected by detector **114** may be detected at time $t_{c2}+t_{2,1}$, e.g., this signal may have been initiated by device **100** and may have triggered transponder **105** to send a second acoustic signal.

[0035] Similarly, **Fig. 2B** illustrates an example of a timing diagram with respect to sonic detector **115**. The diagram in **Fig. 2B** illustrates the signal density over time per all signals detected by sonic detector **115**. For example, the first signal detected by detector **115** may be a signal detected at time $t_{2,2}$ and sent by transponder **105**. This signal may have been triggered by the radio pulse transmitted by radio beacon **103**, e.g., the signal detected at time $t_{2,2}$ may be the first acoustic signal sent by transponder **105**. The second signal that may be detected by detector **115** may have been detected at time $t_{2,2}+t_{c2}$. This second signal detected by detector **115** may be the second acoustic signal sent by transponder **105**, which may have been triggered by an ultrasonic signal transmitted by device **100**. The third signal that may be detected by detector **115** may be detected at time $t_{1,2}$. That is, the third detected signal may be first acoustic signal sent by transponder **104**

(which may have been triggered by the radio pulse). The fourth signal detected by detector **115** may be detected at time $t_{1,2}+t_{c1}$, e.g., this signal may have been initiated by device **100** and may have triggered transponder **104** to send a second acoustic signal.

[0036] Reference is made to **Fig. 3**, which illustrates a schematic timing connection system, in accordance with an embodiment of the present invention. **Fig. 3** illustrates the signal transmission and detection timings that were disclosed with regards to **Fig. 1** above, in a more direct manner. According to **Fig. 3**, the time it may take sonic detector **114** to detect the ultrasonic signal sent by device **100** may be equal to either: $t_{c1}+t_{1,1}$, or to: $t_{c2}+t_{2,1}$. According to **Fig. 3**, the time it may take sonic detector **115** to detect the ultrasonic signal sent by device **100** may be equal to either: $t_{c2}+t_{2,2}$, or to: $t_{c1}+t_{1,2}$.

[0037] The speed of sound in dry air at 20°C is known to be $V_A=343.2$ [m/sec], thus distance between transponders (**104** and **105**) and the sonic detectors (**114** and **115**) may be calculated by the following equation:

$$(1) \text{Distance[m]}=\text{Time[sec]}*\text{Speed[m/sec]}.$$

In addition, the speed of sound in the body (or speed of ultrasound in body tissue) is known to be approximately $V_B\approx 1530$ [m/sec], thus the distance between the device **100** and any of the transponders (**104** and **105**) may also be calculated by equation (1).

[0038] Reference is now made to **Fig. 4**, which illustrates a schematic system assisting in calculations of location of an in-vivo device, in accordance with an embodiment of the present invention. According to equation (1), if the time it takes a signal to reach any of the sonic detectors **114** and **115** is known, then the distance between the sonic detectors **114** and **115** and the components of system **10** (e.g., transponders **104** and **105** and/or device **100**) which sent the signal, may be determined. The following equation may be used in order to calculate the distance between the transponders **104** and **105** and sonic detectors **114** and **115**:

$$(2) \begin{bmatrix} t_{1,1} & t_{1,2} \\ t_{2,1} & t_{2,2} \end{bmatrix} \times V_A = \begin{bmatrix} r_{1,1} & r_{1,2} \\ r_{2,1} & r_{2,2} \end{bmatrix}$$

Whereby, $t_{i,j}$ represents the time it takes a signal to reach a sonic detector (j) when transmitted from a transponder (i), and V_A represents the velocity of sound in dry air.

The following equation may be used in order to calculate the distance between device **100** and transponders **104** and **105**:

$$(3) \begin{bmatrix} t_{c1} \\ t_{c2} \end{bmatrix} \times V_B = \begin{bmatrix} r_{c1} \\ r_{c2} \end{bmatrix}$$

Whereby, t_{ci} represents the time it takes a signal to reach transponder (i) when transmitted from device **100** (for example, device **100** may be an endoscope capsule), and V_B represents the velocity of sound in the body.

[0039] **Fig. 4** illustrates the coordinates (x_1, y_1) of transponder **104** in the coordinates (X, Y) of machine frame **110**. In order to calculate the coordinates (x_1, y_1) of transponder **104** in the machine frame's coordinates, the cosine rule may be used:

$$(4) a^2 = b^2 + c^2 - 2bc \cos \delta ; \text{ Whereby:}$$

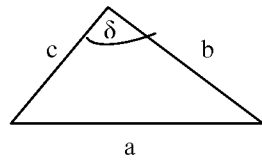

Angle β shown in **Fig. 4**, may be defined between the distance $r_{1,1}$ (i.e., the distance between transponder **104** and sonic detector **114**) and $\sqrt{x_0^2 + y_0^2}$ (i.e., the distance between sonic detector **114** and sonic detector **115**). In order to calculate angle β , equation (4) may be used as follows:

$$(5) \beta = \arccos \left(\frac{x_0^2 + y_0^2 + r_{1,1}^2 - r_{1,2}^2}{2\sqrt{x_0^2 + y_0^2} \cdot r_{1,1}} \right)$$

In order to calculate the (x_1, y_1) coordinates of transponder **104** with respect to the machine frame coordinates (X, Y) , the following equations may be used:

$$(6) y_1 = r_{1,1} \cos(\gamma) + y_0;$$

$$(7) x_1 = r_{1,1} \sin(\gamma);$$

Whereby: $\gamma = 180^\circ - \alpha - \beta = 180^\circ - \arctg(x_0/y_0) - \beta$

[0040] Reference is made to **Fig. 5**, which illustrates a schematic system assisting in calculations of location of an in-vivo device, in accordance with an embodiment of the

present invention. The coordinates (x_2, y_2) of transponder **105** with respect to the coordinates (X, Y) of machine frame **110** may be calculated, following equations (1) to (7) above, with minor adjustments.

Angle β' shown in **Fig. 5**, may be defined between the distance $r_{2,2}$ (i.e., the distance between transponder **105** and sonic detector **115**) and $\sqrt{x_0^2 + y_0^2}$ (i.e., the distance between sonic detector **114** and sonic detector **115**). In order to calculate angle β' , equation (4) may be used as follows:

$$(5') \beta' = \arccos \left(\frac{x_0^2 + y_0^2 + r_{2,2}^2 - r_{2,1}^2}{2\sqrt{x_0^2 + y_0^2} \cdot r_{2,2}} \right)$$

In order to calculate the (x_2, y_2) coordinates of transponder **105** with respect to the machine frame coordinates (X, Y) , the following equations may be used:

$$(6') y_2 = r_{2,2} \cos(\gamma')$$

$$(7') x_2 = x_0 - r_{2,2} \sin(\gamma');$$

Whereby: $\gamma' = 180^\circ - \alpha' - \beta' = 180^\circ - \arctg(x_0/y_0) - \beta'$.

[0041] Reference is now made to **Fig. 6**, which illustrates a schematic system assisting in calculations of location of an in-vivo device, in accordance with an embodiment of the present invention. **Fig. 6** illustrates the coordinates (X_c, Y_c) of the device **100** (e.g., capsule endoscope **100**) with respect to the coordinates (X, Y) of machine frame **110**. The coordinates (X_c, Y_c) of device **100** may be calculated following equations (1) to (7) above, with minor adjustments. Angle β_c shown in **Fig. 6**, may be defined between the distance r_{c1} (i.e., the distance between transponder **104** and device **100**) and $\sqrt{(x_2 - x_1)^2 + (y_1 - y_2)^2}$ (i.e., the distance between transponder **104** and transponder **105**). In order to calculate angle β_c , equation (4) may be used as follows:

$$(5'') \beta_c = \arccos \left(\frac{(x_2 - x_1)^2 + (y_1 - y_2)^2 + r_{c1}^2 - r_{c2}^2}{2\sqrt{(x_2 - x_1)^2 + (y_1 - y_2)^2} \cdot r_{c1}} \right)$$

In order to calculate the (X_c, Y_c) coordinates of device **100** with respect to the machine frame coordinates (X, Y) , the following equations may be used:

$$(6'') Y_c = y_1 + r_{c1} \cos(\gamma_c)$$

$$(7'') X_c = x_1 + r_{c1} \sin(\gamma_c);$$

$$\text{Whereby: } \gamma_c = 180^\circ - \alpha_c - \beta_c = 180^\circ - \arctg\left(\frac{x_2 - x_1}{y_1 - y_2}\right) - \beta_c;$$

and (x_1, y_1) which are the coordinates of transponder **104** with respect to machine frame coordinates were already calculated above (see **Fig. 4**).

[0042] According to some embodiments, the calculations performed with the assistance of **Fig. 6** in order to find the coordinates (X_c, Y_c) of device **100** based on coordinates (x_1, y_1) of transponder **104**, may also be done with respect to coordinates (x_2, y_2) of transponder **105**. The purpose of calculating the coordinates of device **100** for a second time, may be to decrease the noise in these calculations. Noise in these calculation may appear due to lack of accuracy in calculating the distances between the components of system **10** (e.g., $r_{i,j}$, and r_{ci}), which may occur due to lack of accuracy in the measured time it takes a signal to be transmitted from one element of system **10** until it reaches another element of system **10** (e.g., times $t_{i,j}$ and t_{ci}).

[0043] Reference is now made to **Fig. 7**, which illustrates a schematic two-dimensional system for determining location and orientation of an in-vivo device, in accordance with one embodiment of the present invention. In order to determine orientation of in-vivo device **100**, which may assist in better understanding which direction the device **100** is heading while passing through the lumen, device **100** may comprise at least two separate ultrasonic transmitters, e.g., ultrasonic transmitters **101a**, and **101b**. The at least two ultrasonic transmitters (e.g., **101a**, **101b**) may be located at opposite ends of device **100**. Other numbers of ultrasonic transmitters and other locations along the device **100** may be used. The distance (D) between the ultrasonic transmitters **101a** and **101b** may be pre-determined. Thus, coordinates of any of the ultrasonic transmitters with respect to the coordinates (X, Y) of machine frame **110** may be calculated as described above, with respect to device **100** comprising one ultrasonic transmitter **101**.

[0044] According to some embodiments, the transmission frequency of ultrasonic transmitters **101a** and **101b** may be different. Ultrasonic transmitters sending ultrasonic signals at different frequencies may enable distinction between signals that were detected by either of transponders **104** and **105**. Distinction between signals transmitted by the ultrasonic transmitters **101a** and **101b** may enable more accurate calculations of distance

between components of system **10**, thus may enable more accurate calculations of location and orientation of device **100** with respect to the patient's body **102**, and with respect to machine frame **110**. For example, the coordinates of ultrasonic transmitter **101a** with respect to the coordinates (X,Y) of machine frame **110** may be (X_{f1}, Y_{f1}), and the coordinates of ultrasonic transmitter **101b** with respect to coordinates of machine frame **110** may be (X_{f2}, Y_{f2}). In some embodiments, the angle of orientation θ may be calculated as follows:

$$(8) \theta = \arctg \left(\frac{Y_{f2} - Y_{f1}}{X_{f1} - X_{f2}} \right)$$

[0045] According to some embodiments, in order to determine location and orientation of an in-vivo device, such as device **100**, in a 3D system, similar calculations as shown above with respect to equations (1) to (7) may be performed with a few adjustments. For example, in order to determine location, e.g. coordinates (X_c, Y_c, Z_c) of device **100** with respect to the coordinates (X,Y,Z) of machine frame **110**, there is a need for at least three transponders (instead of a minimum of two transponders) and thus there is a need for at least three associated sonic detectors (instead of a minimum of two detectors). In some embodiments, in a 3D system, there may be two angles associated with orientation (e.g., θ_1 , θ_2) of device **100**, both of which may be calculated following equations that may be based upon equation (8) that is shown above with regards to a 2D system, e.g., system **10**. A processor (not shown) may perform all of the calculations needed for determining location and orientation of device **100**. The processor may be located either within device **100**, or located externally to device **100** within machine frame **110**, or may be located externally to machine frame **110**.

[0046] Reference is now made to **Fig. 8**, which illustrates a method for determining location of an in-vivo device, in accordance with one embodiment of the present invention. The method may comprise the step of inserting an in-vivo device into a patient's body (**800**). Inserting an in-vivo device, e.g., device **100**, into a patient's body, may be done by swallowing the device or by inserting it with a delivery device (in order to ease on patients that have difficulties in swallowing). The method may further comprise the step of placing the patient into a machine frame comprising external

magnets (**810**). The machine frame, into which the patient is placed, may be similar to machine frame **110** (**Fig. 1**).

[0047] According to some embodiments, the method may comprise the step of sending a radio pulse through a radio beacon transmitter (**820**). The radio beacon transmitter, e.g., radio beacon **103**, may be located on the machine frame, e.g., frame **110**. The radio beacon may transmit a radio pulse that may trigger transmission of signals of other components within machine frame **110**. Since the speed of radio waves in air is very fast, it may be assumed that the radio pulse reaches all of the components of system **10** substantially simultaneously, thereby determining a start time $t=0$ for later calculations.

[0048] In some embodiments, the method may comprise the step of detecting an ultrasonic signal transmitted from the device (e.g., device **100**) by transponders placed on the patient (**830**). The transponders, e.g., transponders **104** and **105**, may be attached to the patient's body for receiving an ultrasonic signal transmitted by an ultrasonic transmitter (e.g., transmitter **101**, or transmitters **101a** and **101b**). The ultrasonic signal transmitted by the device (e.g., device **100**) may be triggered by the radio pulse sent by the radio beacon, e.g., radio beacon **103**. The method may further comprise the step of sending through each of the transponders an acoustic signal (**840**). The transponders (e.g., transponders **104** and **105**) may be triggered by the radio pulse to send a first acoustic signal, and may be triggered by the ultrasonic signal to send a second acoustic signal. According to some embodiments, in a 3D system, there should be at least three transponders placed on the patient's body in order to determine location and orientation of an in-vivo device, with respect to the system's coordinates.

[0049] The method may further comprise detecting the acoustic signals by sonic detectors located on the frame (**850**). In a 3D system there should be at least three sonic detectors, in order to determine location and orientation of an in-vivo device with respect to the system's coordinates. The sonic detectors (e.g., sonic detectors **114** and **115**) may be attached to the system's frame, e.g., to machine frame **110**.

[0050] The method may further comprise the step of measuring time of detection of signals by a processor (**860**). The time it takes each detected signal to reach the sonic detectors may be measured by a processor. The processor may be located within the in-

vivo device or it may be external to it, either located within the machine frame or it may be located externally to the machine frame as well.

[0051] The method may further comprise the step of calculating location (and orientation) of the device in frame coordinates, and in body coordinates (**870**). In some embodiments, calculations of the location and orientation of the in-vivo device with respect to the coordinates of the system (e.g., system **10** or machine frame **110**) may be performed by the processor. The calculations may be done in accordance with the equations above (e.g., equations (1) to (8)), with adjustments such to conform to 3D systems instead of 2D systems. In some embodiments, in order to determine location of an in-vivo device in a 3D system, the (X,Y,Z) coordinates of the device may be calculated according to equations (1) to (7) with the necessary adjustments from 2D systems to 3D systems. In order to determine orientation of the in-vivo device, the orientation angles (e.g., angle θ) may be calculated according to equation (8) with the necessary adjustments from 2D systems to 3D systems. In some embodiments, in order to determine orientation of an in-vivo device, at least two ultrasonic transmitters should be incorporated into the in-vivo device (e.g., ultrasonic transmitters **101a** and **101b**). The angle θ between the at least two ultrasonic transmitters, which is associated with orientation of the device, may be calculated in accordance with equation (8).

[0052] Reference is now made to **Fig. 9**, which illustrates a schematic two-dimensional system for determining location of an in-vivo device, in accordance with another embodiment of the present invention. System **90** of **Fig. 9** may comprise a machine frame **110**, which may comprise external magnets, similarly to the machine frame described in **Fig. 1**. Patient **102** may be placed within machine frame **110** of system **90**. An in-vivo device **200** may be pre-inserted into patient **102** before the patient is placed within machine frame **110**. Though, in other embodiments, device **200** may be inserted into patient **102** after the patient **102** is positioned within machine frame **110**. Device **200** may comprise a housing that may comprise a proper coating such that device **200** may be a strong reflector. In some embodiments, instead of device **200** comprising an ultrasonic transmitter that may send ultrasonic signals (**Fig. 1**), the housing of device **200** may act as a reflector, so as to reflect an ultrasonic signal that may be sent towards it.

In some embodiments, device **200** may comprise corner reflectors instead of a reflecting coating.

[0053] In some embodiments, in a 2D system, patient **102** may have attached at least two transceivers **140** and **150**. Transceivers **140** and **150** may send ultrasonic pulses into the body at a wide angle (e.g., an angle that exceeds 90°). In some embodiments, system **90** may further comprise a radio beacon **103** that may send a radio pulse in order to activate the at least two transceivers **140** and **150**. 2D system **90** may further comprise at least two sonic detectors **141** and **151**.

[0054] According to some embodiments, the radio sync pulse (sent by radio beacon **103**) may trigger transceivers **140** and **150** to send their corresponding wide angle ultrasonic pulses towards device **200**. Simultaneously, the transceivers **140** and **150** may each send a first sonic pulse, which may be received by sonic detectors **141** and **151**. When a reflected pulse from device **200** is received by each of the transceivers **140** and **150**, a second sonic pulse may be emitted from each of transceivers **140** and **150** towards sonic detectors **141** and **151**.

[0055] Reference is now made to **Figs. 10A-10B**, which illustrate schematic distance estimation between an in-vivo device and a component of the system based on time, in accordance with an embodiment of the present invention. **Fig. 10A** illustrates transceiver **140** that may send an ultrasonic pulse **40**. The ultrasonic pulse **40** may reach device **200**. Since device **200** may comprise a reflecting coating, the ultrasonic pulse may be reflected off device **200**, thus creating a reflected wave **42**, which may be reflected back towards transceiver **140**. **Fig. 10B** illustrates a time diagram that may be used to calculate the distance between the transceiver **140** and device **200**. The time it takes an ultrasonic signal to be sent from transceiver **140** to device **200** and then be reflected off device **200** to be received by transceiver **140** may approximately be equal to twice the distance between the transceiver (e.g., transceiver **140**) and device **200** divided by the speed of sound in the body. The distance may be calculated based on equation (1) above. Time (t) may be calculated by transceiver **140**, and the velocity of sound in the body (V_B) is known to be approximately $V_B \approx 1530$ [m/sec], thus distance (R) between the transceiver **140** and device **200** may be: $2R = t * V_B$. The distance R is multiplied by two, since the

ultrasonic signal travels from the transceiver and back to it again, so the distance between the transceiver and the device **200** is passed twice by the signal.

[0056] According to some embodiments, determining location of the in-vivo device **200** with respect to the coordinates of machine frame **110** may be calculated based on equations (1) to (7) above, with the adjustments of the calculation of distance between device **200** and each of transceivers **140** and **150**. In some embodiments, in order to determine location of in-vivo device **200** in a 3D system, adjustments should be made to equations (1) to (7). For example, in a 3D system, the system should comprise at least three transceivers and at least three sonic detectors.

[0057] Reference is now made to **Figs. 11A-11B**, which illustrate schematic orientation estimations of an in-vivo device based on reflected pulse shape, in accordance with an embodiment of the present invention. **Fig. 11A** illustrates an example of orientation of device **200**, where the longitudinal axis of device **200** intersects with the center of one of the transceivers, e.g., transceiver **140**. Since the cross section of device **200** is minimal, the reflected ultrasonic signal (**R**) (reflected off device **200**) may have substantially the same shape as the transmitted signal (**S**) (transmitted by the transceiver), e.g., the same width: $W_R=W_S$. However, the intensity of the reflected signal is in fact half of the intensity of the transmitted signal.

[0058] **Fig. 11B** illustrates an additional example of orientation of device **200**. **Fig. 11B** illustrates a device **200** tilted with respect to the center of the transceiver (e.g., transceiver **140**). Thus, one end of device **200** may be located closer to the transceiver than the other end of device **200**. The reflection from the proximal end (**R_p**) may arrive to the transceiver (e.g., transceiver **104**) before the reflection from the more distal end (**R_d**) of device **200**. Such a difference in time of reflection may result in stretching of the reflected signal, thus the corresponding half intensity width W_R may be wider than the width W_S of the transmitted signal (**S**). That is, the reflected signal's width may be an indication of the tilt angle (φ) of device **200**. The following equation may be used in order to determine the tilt angle (φ):

$$(10) \sin \varphi = \frac{W_R - W_S}{W_{R_{\max}} - W_S}$$

Therefore, when $W_R=W_S$, then $\text{Sin}(\varphi)=0$, and tilt angle $(\varphi)=0^\circ$. Whereas, when $W_R=W_{S_{\text{max}}}$, then $\text{Sin}(\varphi)=1$, and tilt angle $(\varphi)=90^\circ$. Tilt angles in between the two orientations that are illustrated in Figs. 11A-B, may be calculated according to the same equation (10).

[0059] Reference is now made to Figs. 12A-12B, which illustrate schematic reflection patterns on the in-vivo device, in accordance with an embodiment of the present invention. In some embodiments, device 200 may comprise two imaging systems located at opposite ends of device 200. In other embodiments, device 200 may comprise only one imaging system 210, which may be located at one end of device 200, while the other end 220 does not comprise an imaging system. In embodiments where device 200 may comprise only one imaging system 210, there is a need to distinguish between the ends of device 200, i.e., determine orientation of each of the different ends of device 200, in addition to determining tilt angle (φ) (Figs. 11A-11B). Therefore, in some embodiments, the housing of device 200 may be designed such to reflect a strong signal (e.g., high intensity) from one end, while reflecting a lower signal from the other end (e.g., low intensity). According to Fig. 12A, if the end 210, which comprises the imaging system, is designed to reflect a stronger signal than end 220, the first reflected signal, which may be received by transceiver 140, may be lower than the second received signal, since end 220 is closer to transceiver 140 than end 210. However, as shown in Fig. 12B, the first reflected signal which may be received by transceiver 140 may be stronger than the second received signal, since in Fig. 12B end 210 is closer to transceiver 140 than end 220.

[0060] Reference is now made to Figs. 13A-13D, which illustrate a schematic modulation pattern on the housing of the in-vivo device, and captured reflected signals indicating roll angle, in accordance with an embodiment of the present invention. According to Fig. 13A, the device 200 may also have a roll angle (ψ) , i.e., device 200 may roll around its own longitudinal axis. This may change the orientation of images acquired at different roll angles (ψ) . In some acquired images, an object in the image may be located at the top of the image, whereas the same object may be located at the bottom of the acquired image, if the device 200 had rolled around itself between acquisitions of these images. In order to determine roll angle (ψ) , the device 200 may be coated in such a

way that modulates the reflectivity. In some embodiments, by incorporating a ring **213** of variable reflectivity around the center of the circumference of device **200**, a modulation notch may appear at the center of the reflected signal (**Fig. 13B**). The depth (d) of the notch may be indicative of the roll angle (ψ), as defined by the following equation:

$$(11) \psi = k \cdot d ; \quad \text{wherein (k) is a constant.}$$

[0061] Accordingly, the roll angle (ψ) may be determined by the depth (d) of the notch. When (d) is relatively small (e.g., **Fig. 13B**), roll angle (ψ) is also small, e.g., device **200** has just begun to roll. Whereas, when (d) is relatively large (e.g., **Fig. 13C**, **Fig. 13D**), roll angle (ψ) is larger than before, e.g., device **200** has rolled in a substantial angle compared to its initial orientation. **Figs. 13A-13D** illustrate a reminiscent of radio AM modulation. Other modulations may be used, such as FM modulation.

[0062] While the present invention has been described with reference to one or more specific embodiments, the description is intended to be illustrative as a whole and is not to be construed as limiting the invention to the embodiments shown. It is appreciated that various modifications may occur to those skilled in the art that, while not specifically shown herein, are nevertheless within the scope of the invention.

CLAIMS

1. A system for determining location of an in-vivo device, the system comprising:
 - a frame comprising external magnets and magnetic actuators for surrounding a patient's body, said body comprising an in-vivo device, wherein said external magnets are for applying magnetic forces on said in-vivo device;
 - a radio beacon transmitter attached to the frame for transmitting a radio pulse;
 - wherein said in-vivo device comprises an ultrasonic transmitter for transmitting an ultrasonic signal that is triggered by said radio pulse;
 - at least three transponders placed on the patient's body, each transponder sending a first acoustic signal triggered by the radio pulse, and each sending a second acoustic signal triggered by the in-vivo device's ultrasonic signal;
 - at least three sonic detectors located on the frame for detecting each of the transponders' first and second acoustic signals; and
 - a processor for measuring time of detection of said transponders' signals and calculating location of the in-vivo device in frame coordinates, and in body coordinates.
2. The system according to claim 1, wherein each transponder comprises an ultrasonic receiver and a sonic transmitter.
3. The system according to claim 1, wherein said sonic detectors are connected to the processor.
4. The system according to claim 1, wherein said in-vivo device comprises at least two ultrasonic transmitters, each transmitting an ultrasonic signal having a different frequency.
5. The system according to claim 1, wherein said in-vivo device is a swallowable capsule endoscope.

6. The system according to claim 1, wherein said device comprises tools for performing operations at a target location in-vivo.
7. The system according to claim 1, wherein said device comprises an internal magnet.
8. A method for detecting location of an in-vivo device, the method comprising:
 - inserting an in-vivo device into a patient's body, said device comprising an ultrasonic transmitter;
 - placing the patient into a frame surrounding said patient, the frame comprising external magnets for applying magnetic forces on the in-vivo device;
 - sending a radio pulse through a radio beacon transmitter to at least three transponders placed on the patient, and to the in-vivo device, for triggering each of the transponders to transmit an acoustic signal and for triggering the device to transmit an ultrasonic signal at substantially the same time period;
 - detecting the ultrasonic signal transmitted from the device by said transponders placed on the patient;
 - sending through each of the transponders an acoustic signal that is triggered by the device's ultrasonic signal;
 - detecting the acoustic signals sent through each of the transponders by at least three sonic detectors located on the frame;
 - measuring time of detection of signals by a processor; and
 - calculating location of the device in frame coordinates, and in body coordinates.
9. The method according to claim 8, wherein said device comprises at least two ultrasonic transmitters each transmitting an ultrasonic signal, and wherein calculating the location of the device comprises calculating the location of each of the device's ultrasonic transmitters, thus calculating the in-vivo orientation of the device.

10. The method according to claim 8, wherein said in-vivo device is a swallowable capsule endoscope.

11. A method for detecting location of an in-vivo device, the method comprising:
 - inserting an in-vivo device into a patient's body, said device comprising a coating so as to reflect an ultrasonic signal;
 - placing the patient into a frame surrounding said patient, the frame comprising external magnets for applying magnetic forces on the in-vivo device;
 - sending a radio pulse through a radio beacon transmitter to at least three transponders placed on the patient, for triggering each of the transponders to transmit a first sonic signal and for triggering each of the transponders to send an ultrasonic signal towards the in-vivo device, at substantially the same time period;
 - detecting a reflected ultrasonic signal reflected off the device, by said transponders placed on the patient;
 - sending through each of the transponders a second sonic signal, which is triggered by the device's reflected ultrasonic signal;
 - detecting the first and second sonic signals sent through each of the transponders, by at least three sonic detectors located on the frame;
 - measuring time of detection of signals by a processor; and
 - calculating location of the device in frame coordinates, and in body coordinates.

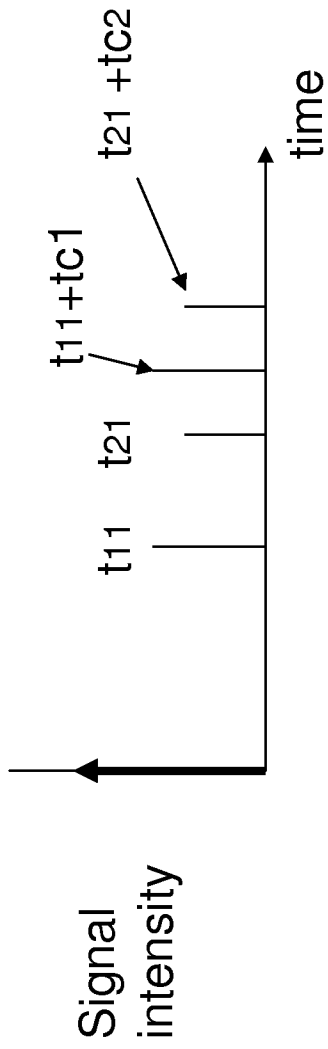

FIG. 2A

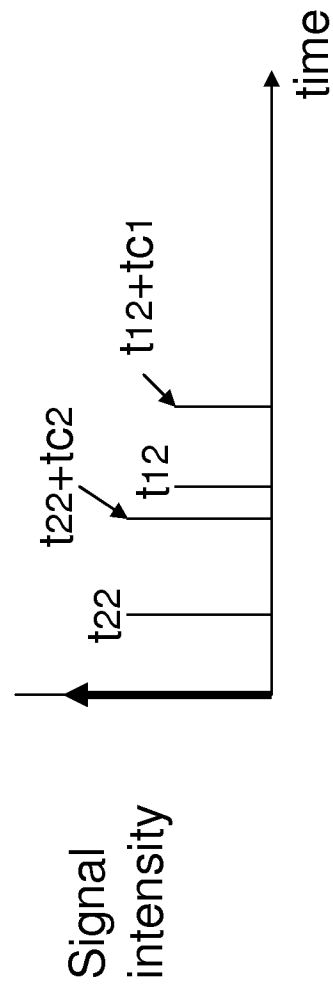

FIG. 2B

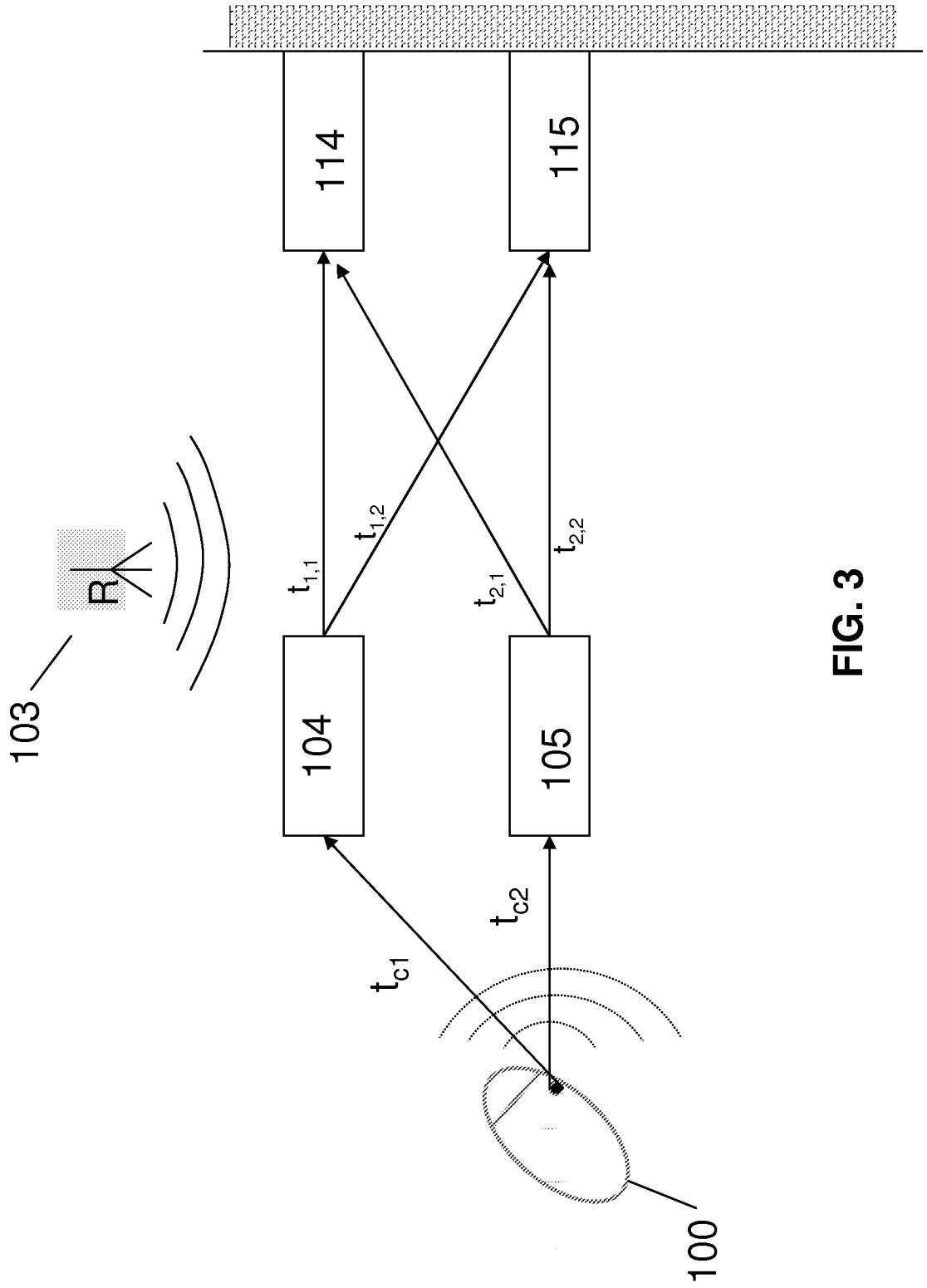

FIG. 3

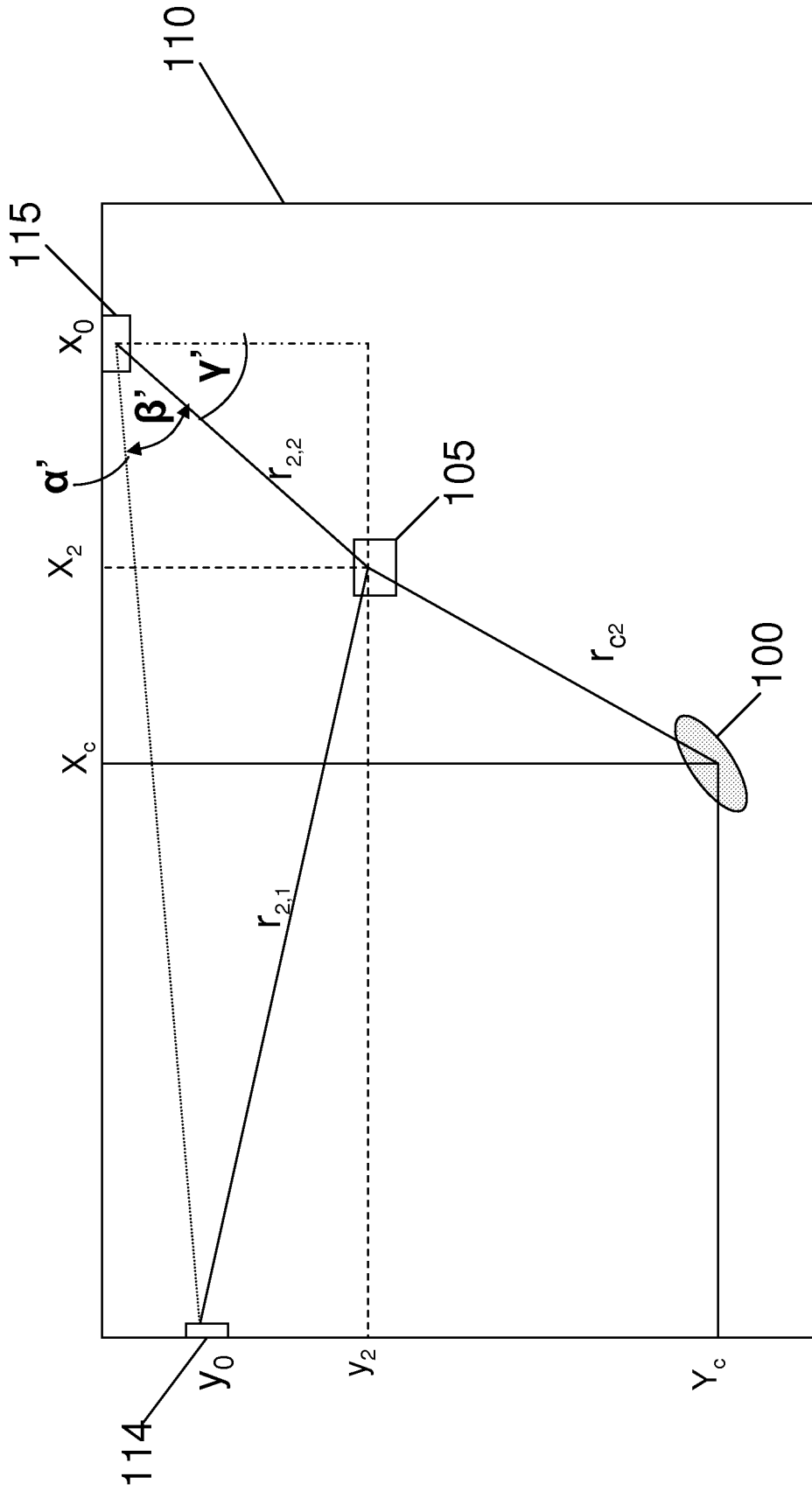

FIG. 5

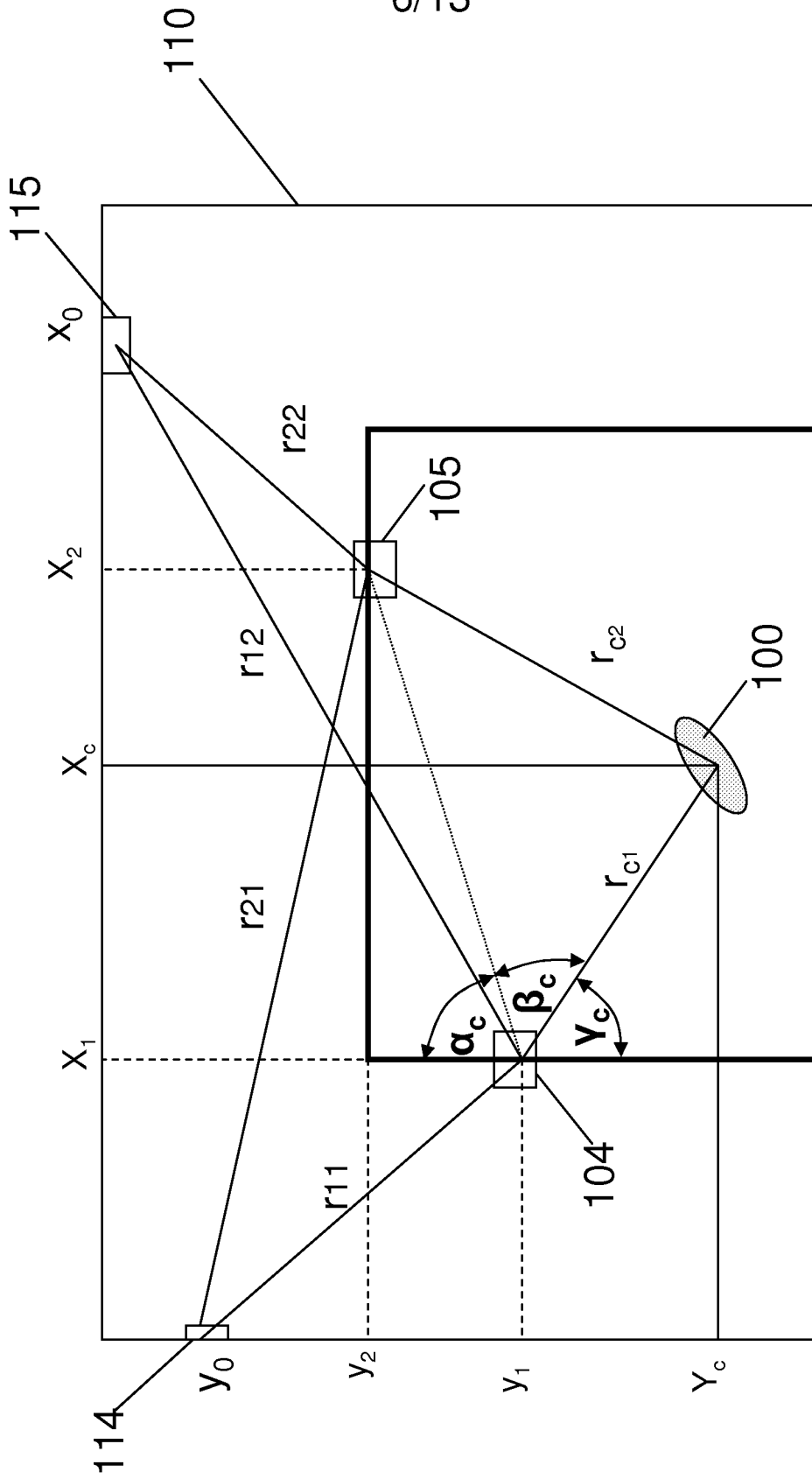

FIG. 6

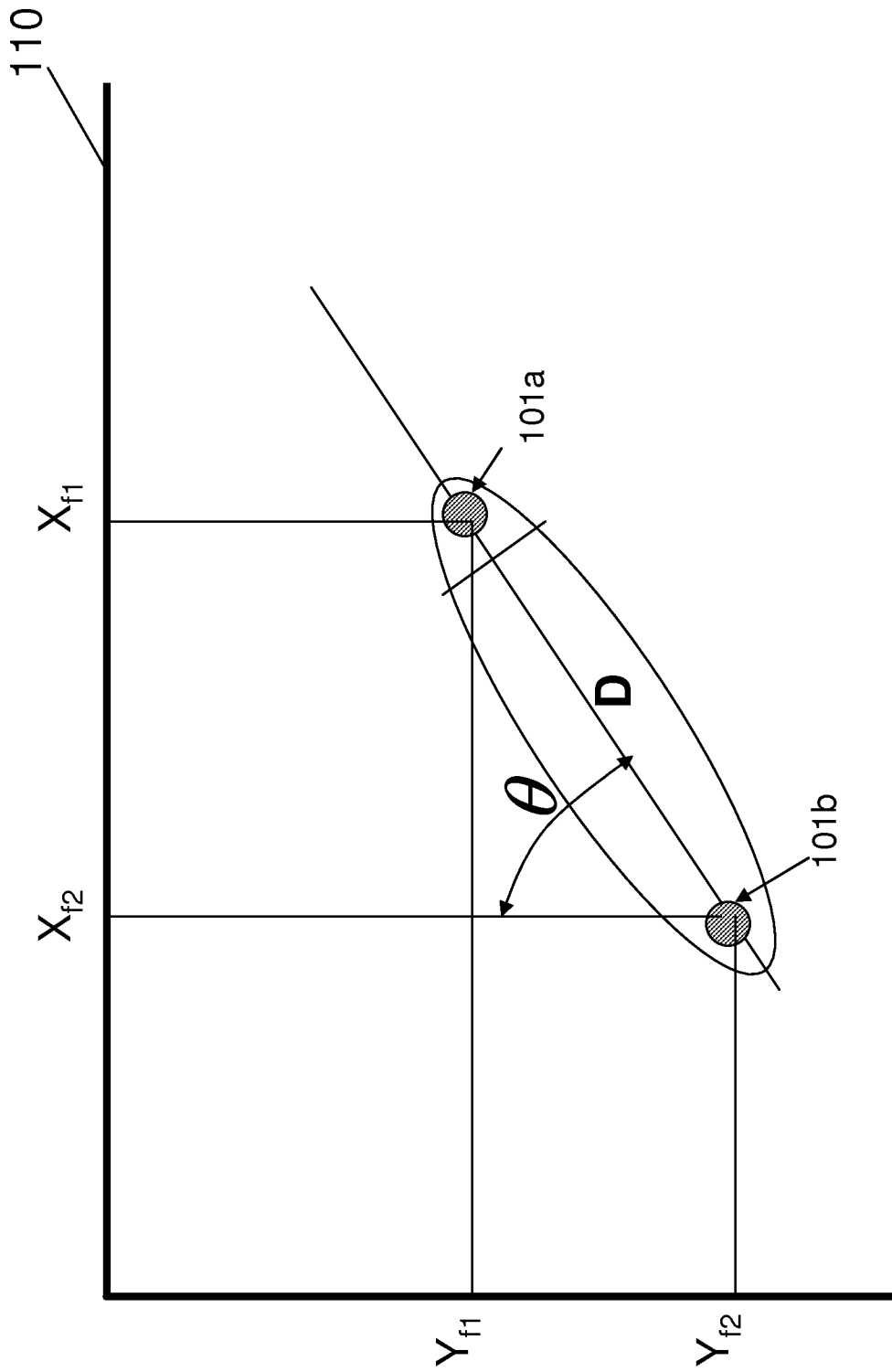

FIG. 7

8/13

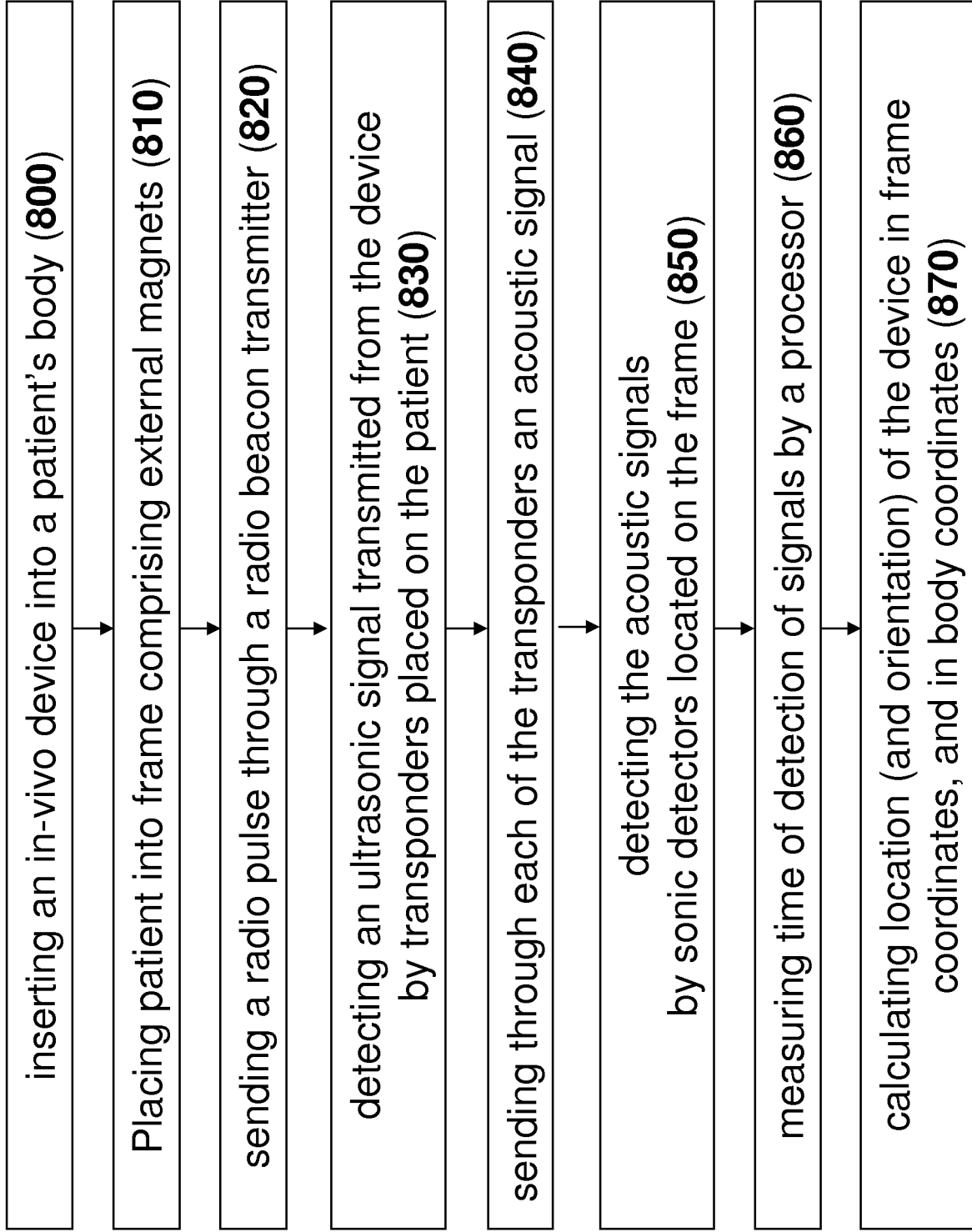

FIG. 8

9/13

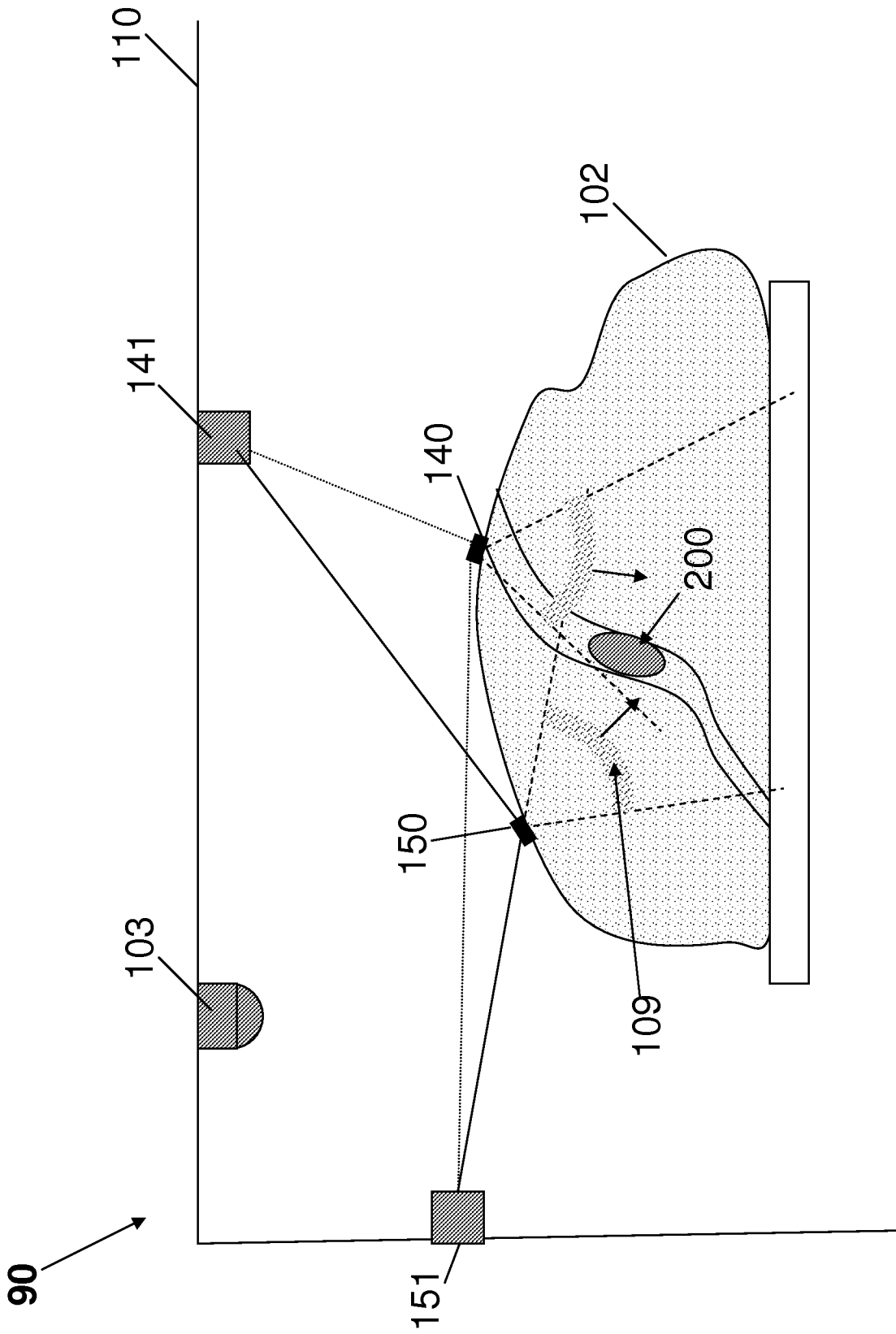

FIG. 9

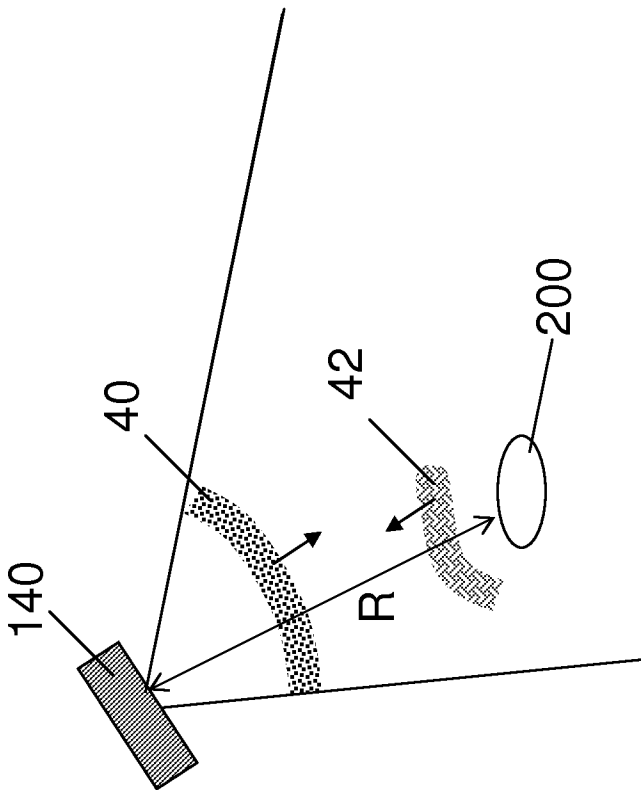

FIG. 10A

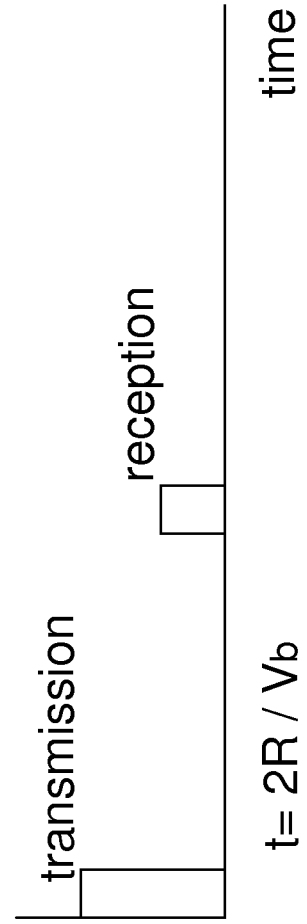

FIG. 10B

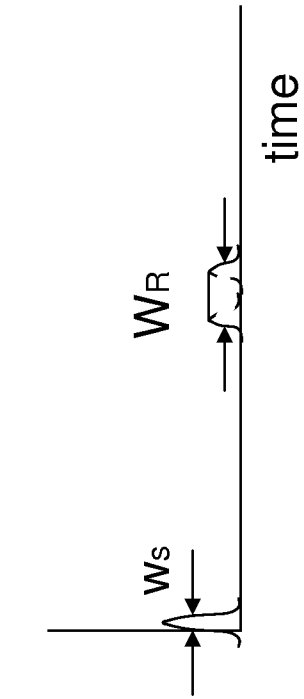
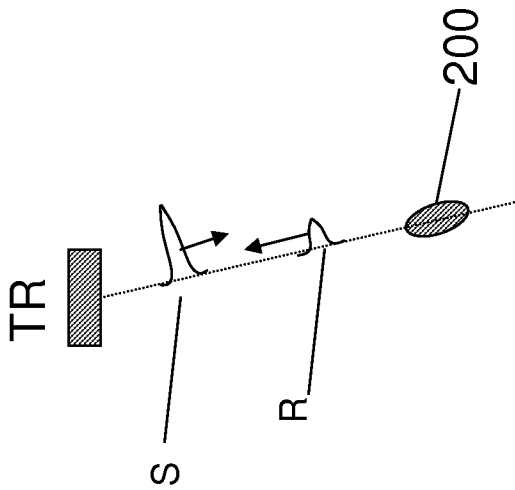
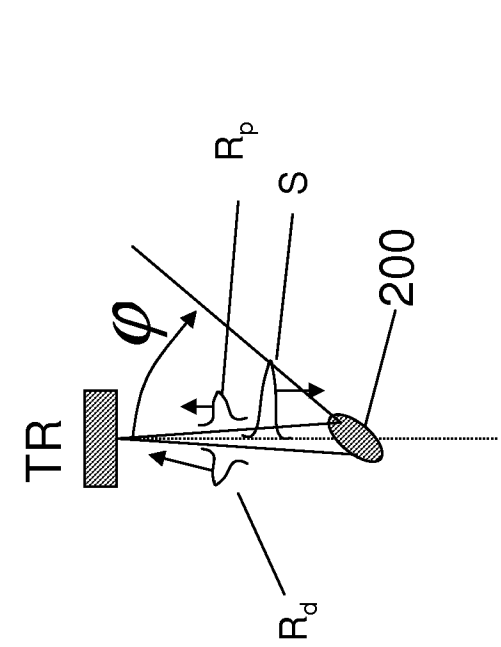

FIG. 11B

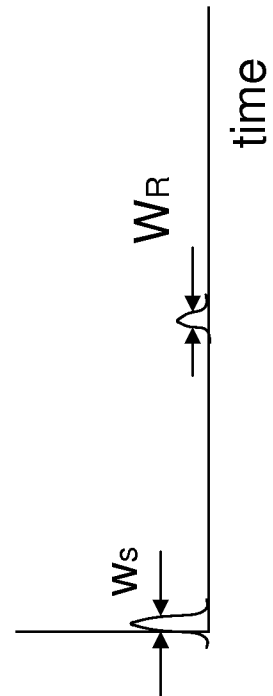

FIG. 11A

12/13

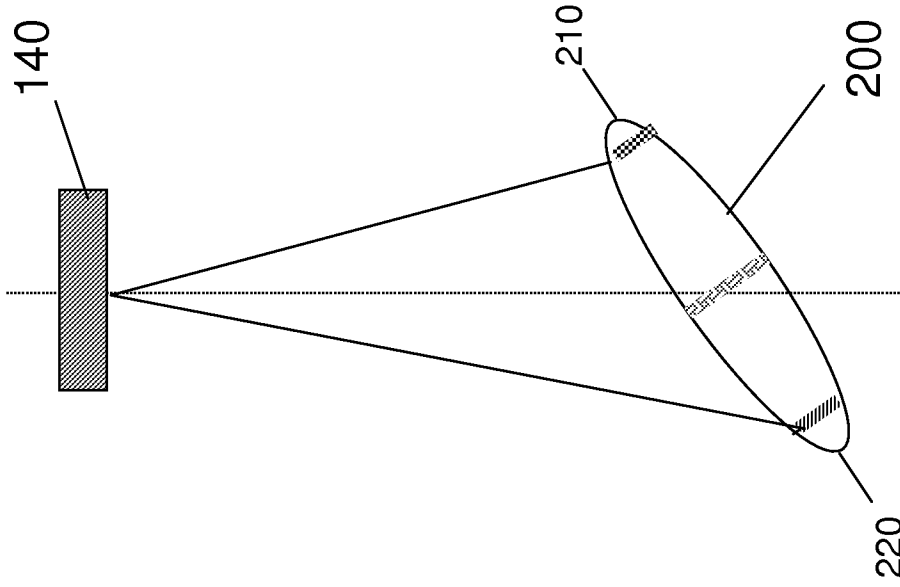

FIG. 12B

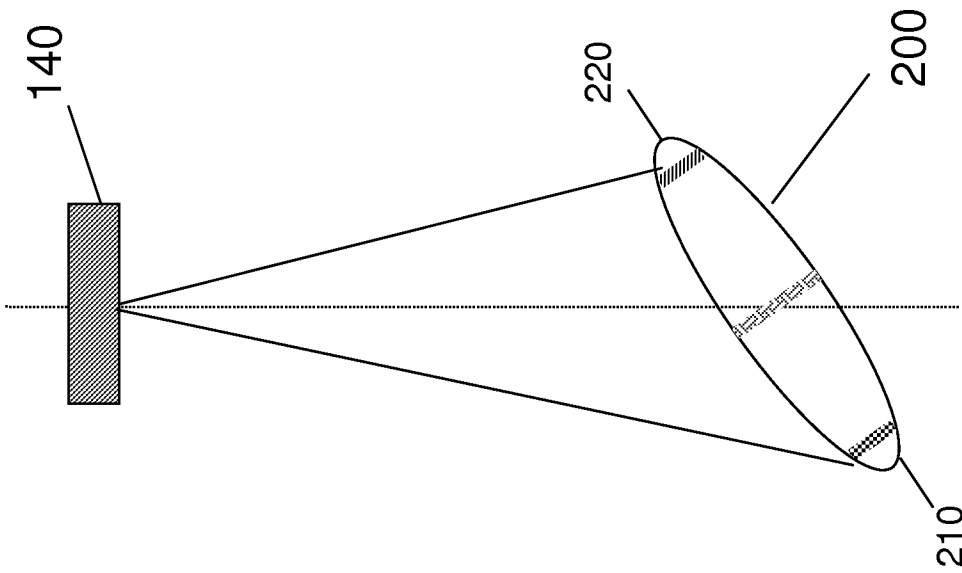

FIG. 12A

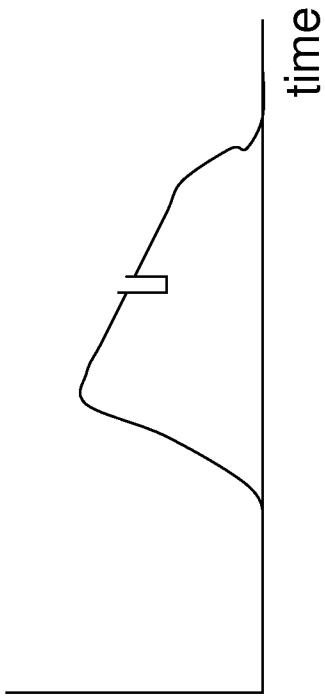
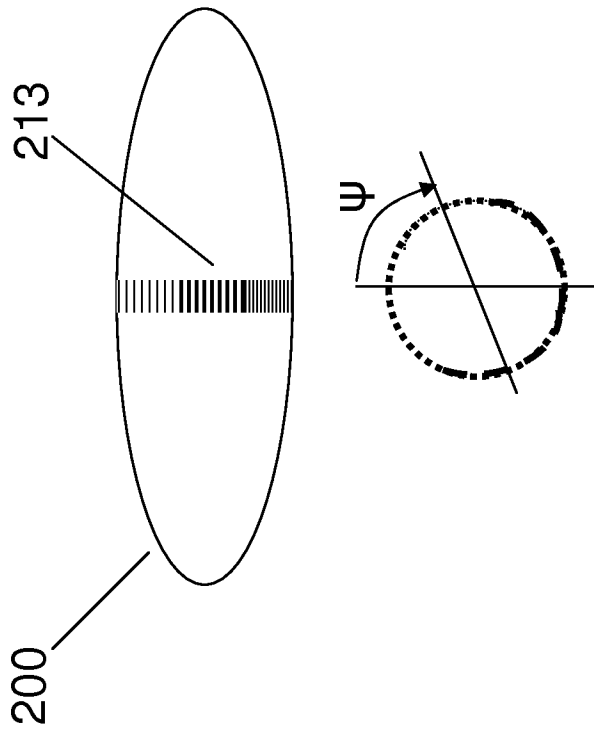

FIG. 13B

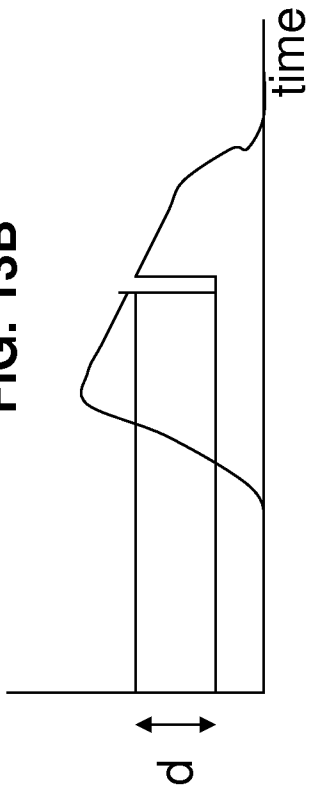

FIG. 13C

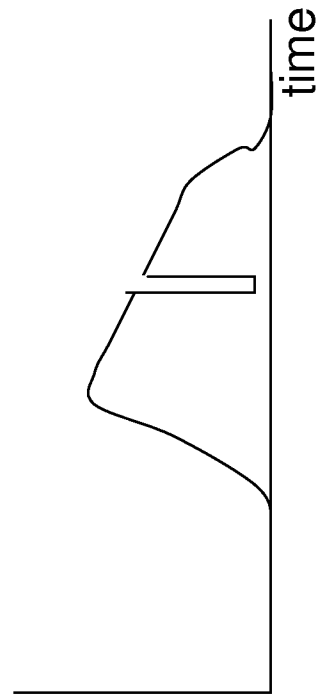

FIG. 13D