

(No Model.)

W. SHEMPP.  
SANDPAPER HOLDER.

No. 470,794.

Patented Mar. 15, 1892.

Fig. 1.

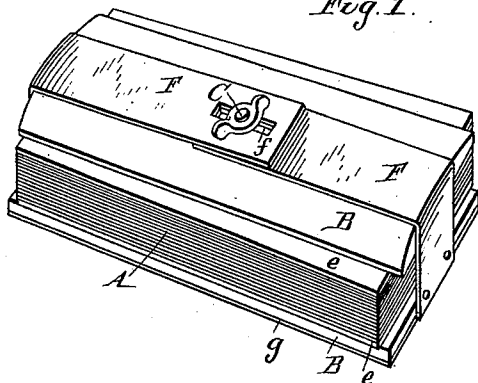

Fig. 2.

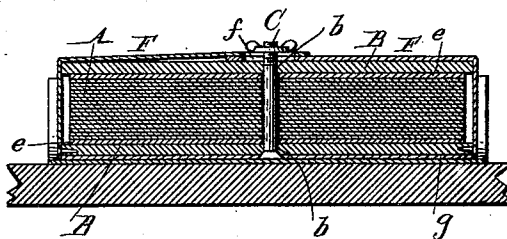

Fig. 3.

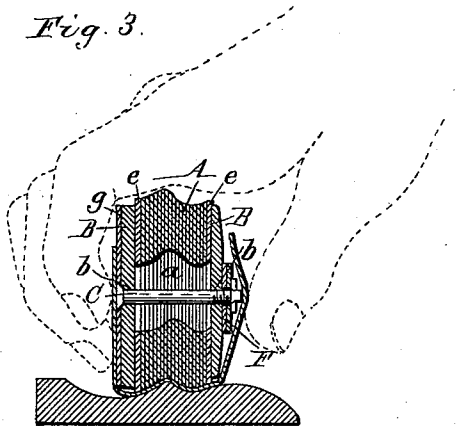

Fig. 4.

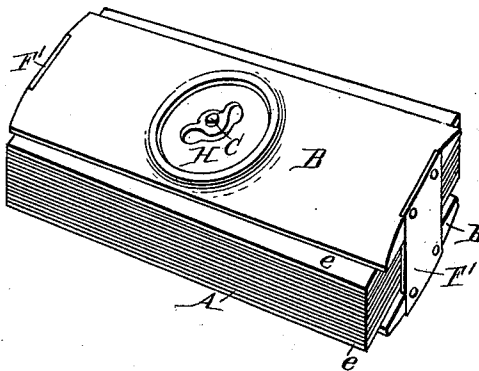
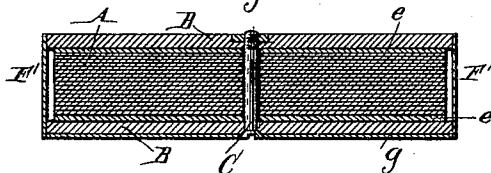

Fig. 5.



Witnesses:

Emil Neuhart.  
Fred. C. Geyer.

William Shempp Inventor.

By Wilhelm Arnold.  
Attorneys

# UNITED STATES PATENT OFFICE.

WILLIAM SHEMPP, OF BUFFALO, NEW YORK.

## SAND-PAPER HOLDER.

SPECIFICATION forming part of Letters Patent No. 470,794, dated March 15, 1892.

Application filed September 14, 1891. Serial No. 405,582. (No model.)

*To all whom it may concern:*

Be it known that I, WILLIAM SHEMPP, a citizen of the United States, residing at Buffalo, in the county of Erie and State of New York, have invented new and useful Improvements in Sand-Paper Holders, of which the following is a specification.

This invention relates to a holder for supporting a piece of sand-paper in smoothing or polishing moldings and other wood-work having a curved or irregular surface. In polishing such surfaces it is inconvenient to reach deep or narrow depressions in the same by simply holding the sand-paper in the hand, and in order to properly polish such work a block or backing of wood having its edge shaped to the work has been heretofore employed, the sand-paper being folded over the working edge of the block and held in place by the hand. While such a block is serviceable for the purpose, it can be used only in connection with the particular work to which its edge is conformed, so that different blocks are required for different styles of molding or other work.

The object of my invention is the production of an adjustable backing block or holder whose working edge can be readily varied to fit the contour of moldings or other wood-work of different designs, thus obviating the necessity of providing a separate backing-block for each kind of work.

In the accompanying drawings, Figure 1 is a perspective view of my improved holder. Fig. 2 is a longitudinal section thereof. Fig. 3 is a transverse central section of the same. Fig. 4 is a perspective view of a slightly-modified form of the holder. Fig. 5 is a longitudinal section of a modified form of such holder.

Like letters of reference refer to like parts in the several figures.

The holder consists, essentially, of a number of thin plates or layers A, of any suitable material, which are movably clamped together side by side, so that the several plates or layers may be adjusted in the holder to cause their plain working edges to collectively conform to the surface to be smoothed or polished, and thus serve as a backing for a sheet of sand-paper. The layers A are preferably constructed of rubber or other flexible ma-

terial, so as to form a yielding backing for the sand-paper placed over the same, and thereby cause the sand-paper to wear longer. The flexible layers are clamped between two boards or plates B by a screw or bolt C passing through transverse slots *a*, formed in the layers, and openings *b*, formed in the clamping-boards. The clamping-boards are narrower than the layers A, so that the longitudinal edges of the latter project beyond the boards. Sheets of pasteboard *e* are preferably interposed between the outermost layers A and the clamping-boards to stiffen such layers and prevent the same from being deflected outward under the pressure exerted upon the holder.

F are retaining-strips connecting the ends of the clamping-boards B, and which hold the layers A against lengthwise displacement. Each retaining-strip is preferably secured at one end to one of the clamping-boards and extends over the adjacent end of the other board, the two strips overlapping each other and being provided in their lapped portions with longitudinal slots *f*, through which the clamping-bolt C passes. This construction permits the thickness of the block to be varied by inserting a greater or less number of layers between the clamping-boards. The slots in the strips F permit the latter to be moved inwardly or outwardly in moving the clamping-boards toward and from each other for increasing or reducing the thickness of the holder.

In adjusting the holder to molding or other wood-work the clamping-bolt C is loosened and the loose layers are firmly pressed against the surface to be polished, so as to cause the plain edges of all of the layers to bear against the same, the edges of those layers which bear against the depressions of the work being projected, while those bearing against the elevations are caused to recede, as shown in Fig. 3, thus giving the laminated holder an irregular edge, which is the reversed counterpart of the work to be polished. The transverse slots of the layers permit the latter to slide upon each other in adjusting them. After adjusting the layers they are clamped in position by tightening the bolt C. A sheet of sand-paper is then placed over the working edge of the holder and held against its sides,

as shown by dotted lines in Fig. 3. The holder thus forms a yielding backing for the sandpaper, whose edge is readily adjusted to moldings or curved surfaces of various shapes. If the block is not desired to be adjustable with reference to its thickness, the ends of the clamping-boards B may be connected by short strips F', which extend only across the ends of the holder, as represented in Figs. 4 and 5.

If desired, the flat side of the clamping-board, in which the head of the connecting-bolt C is seated, may be used as a backing for polishing flat surfaces. For this purpose said clamping-board is preferably provided with a facing *g* of rubber or other soft material.

Instead of being raised, as shown in Figs. 1, 2, and 3, the thumb-nut of the clamping-bolt may be countersunk and bear against a dished plate H, secured in a recess in the adjacent clamping-board, as shown in Fig. 4. If preferred, the nut may be held against turning and the bolt be turned in the same in clamping the parts together, in which case the head of the bolt is nicked to receive a screw-driver, as represented in Fig. 5.

I claim as my invention—

1. A holder or backing-block for a sheet of abrading material, consisting of a number of plates having plain working edges and adju-  
stably secured together side by side, where-  
by the plates may be shifted inwardly or out-  
wardly to cause their plain working edges to

conform collectively to the surface of the work to be polished, substantially as set forth.

2. A holder or backing-block for a sheet of abrading material, consisting of a number of slotted plates, boards between which the plates are confined, and a clamping-bolt connecting said boards and passing through the slots of the plates, substantially as set forth.

3. A holder or backing for a sheet of abrading material, consisting of a number of plates or layers provided with transverse slots, boards between which the layers are arranged, a clamping-bolt connecting said boards and passing through the slots of the layers, and retaining-strips extending across the ends of said plates or layers, substantially as set forth.

4. A holder or backing for a sheet of abrading material, consisting of a number of plates or layers provided with transverse slots, boards between which the layers are arranged, a clamping-bolt connecting said boards, and retaining-strips secured to one of the boards and extending over the ends of the other board and provided in their adjacent ends with slots through which said clamping-bolt passes, substantially as set forth.

Witness my hand this 7th day of September, 1891.

WILLIAM SHEMPPE.

Witnesses:

CARL F. GEYER,  
FRED. C. GEYER.