

G. W. PERO.
AXLE LUBRICATOR.
APPLICATION FILED MAY 4, 1904.

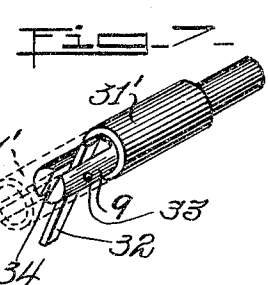

WITNESSES:
C. A. Jarvis
R. H. Jarvis

INVENTOR
George W. Pero.

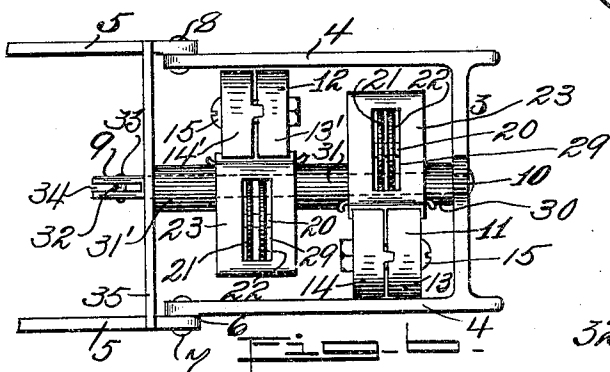
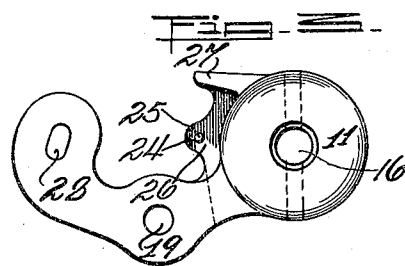
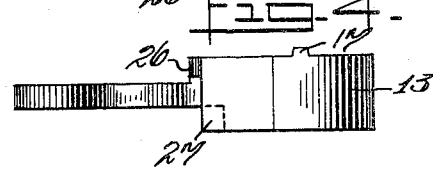
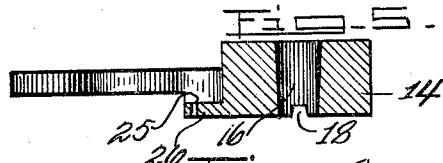
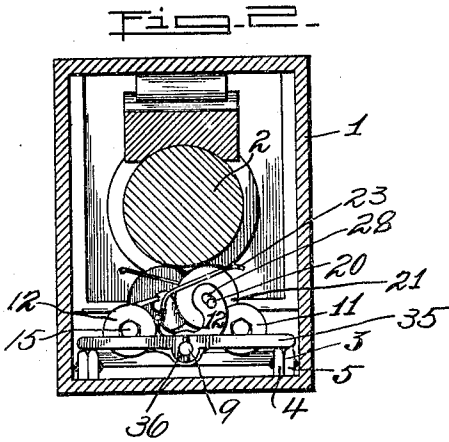
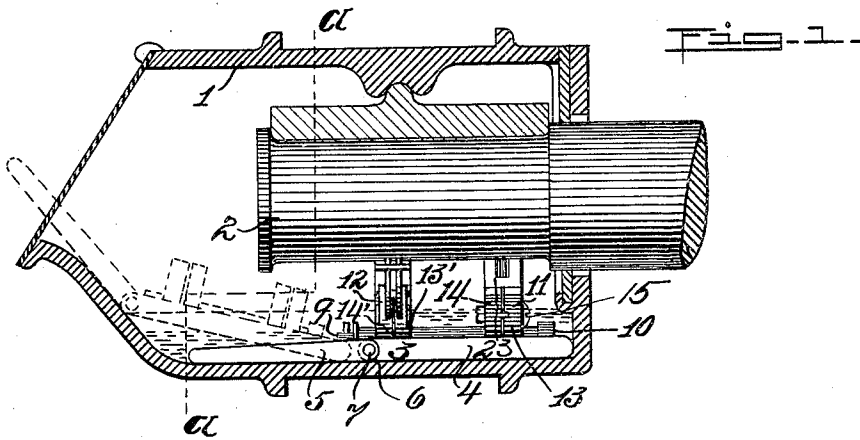
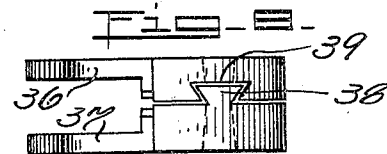

UNITED STATES PATENT OFFICE.

GEORGE W. PERO, OF WEST NEW BRIGHTON, NEW YORK.

AXLE-LUBRICATOR.

SPECIFICATION forming part of Letters Patent No. 793,677, dated July 4, 1905.

Application filed May 4, 1904. Serial No. 206,346.

To all whom it may concern:

Be it known that I, GEORGE W. PERO, a citizen of the United States, and a resident of West New Brighton, in the county of Richmond and State of New York, have invented certain new and useful Improvements in Axle-Lubricators, of which the following is a specification.

This invention relates to a lubricating means whereby an axle-journal can be lubricated at different points simultaneously, this means being a plurality of frames pivotally mounted upon a suitable support, each frame being equipped with oiling-disks, one of the objects of this invention being to provide a flexible support for the said frames in order that the frames can be inserted in a car-axle box without the necessity of disassembling the box.

Other advantages will be presented hereinafter.

In the drawings forming part of this specification, Figure 1 represents a central longitudinal section of an axle-box with the support and frames in position. Fig. 2 is a cross-section taken upon a line *a a* of Fig. 1. Fig. 3 is a side elevation of the pivotal frame upon an enlarged scale. Fig. 4 is a plan view of Fig. 3 and represents the male member of the frames. Fig. 5 is a plan view of the female member of the frames and is partially in section to better illustrate construction. Fig. 6 is a plan view, upon an enlarged scale, of the support and frames thereupon. Fig. 7 is a detail view in perspective of the end of the pivotal frame carrier or spindle and shows the means for retaining the frames in position. Fig. 8 is a modified form of frame having the means for holding the members together integral therewith.

Referring now to the drawings and commencing with Fig. 1, 1 represents a car-axle box of the usual type, which contains a journal 2. Under the said journal and resting upon the floor of the box is a flexible support 3, consisting of two members 4 and 5, pivoted at 6 by rivets 7 and 8, (see Fig. 6,) the purpose of making the support flexible being to allow the device to be inserted in a car-axle box without the necessity of taking the box apart, which would

be necessary if the said support was rigid throughout. (See dotted position, Fig. 1.) Upon a spindle 9, which is rigidly connected to the member 4 of the support 3 at the point 10, are pivotally mounted two frames 11 and 12, the said frames being weighted upon one end and are composed of two members 13 14 and 13' 14', respectively, held together by a bolt 15, the point of insertion being through cored holes 16. (See Figs. 3, 4, 5.) Upon one of the members of each frame, and taking 13 for an example, a projection 17 is formed, which is adapted to enter a recess 18, formed in the other member, as 14, for the purpose of retaining the members in the desired position without the necessity of fitting the bolt 15 to the holes. The hole 19 is the point of insertion of the spindle 9. At the lighter end of the frame members an elongated opening 23 is formed, and within this opening a spindle 20 is adapted to be placed.

For the purpose of supplying the journal with sufficient oil I preferably place upon the spindle 20 two oiling-disks 21 22, and it should be understood that I can employ any number of these disks by the variation of thickness of the weighted ends of the frame members. For the purpose of preventing a surplus amount of oil from being delivered I pivot a wiper or scraper 23 at a point 24, the said point being an opening 25, formed in a lug 26, which is integral with the frame members, and to prevent the said wiper from being forced to an extent which would disengage it from the disks I form integral with the frame members a projection 27, which would engage the said wiper in the event of its being forced backward too far. As can be seen by Fig. 6, the disks 21 22 pass through an opening 29 and contact the wiper at each end of the said opening, (see Fig. 2,) the wiper resting in contact with the disks by virtue of its weight.

The frames 11 12 may be placed at any desired point upon the spindle 9 by the interposition of separators 30 31 31', and any desired number of frames may be used.

For the purpose of preventing the dislodgment of the frames I employ a special means consisting of a latch 32, pivoted by a pin 33 in a slot 34 in the end of the spindle 9. By

rotating the latch to lie within the slot (see dotted position, Fig. 7) the frames can be taken off, and when it is caused to stand at an angle to the axis of the spindle it will prevent the frames from working off, as illustrated by the full-line position in Fig. 7.

In order that the spindle 9 will not be bent by any chance, I preferably employ a detachable means consisting of a strip of metal 35, having an opening 36, adapted to allow the spindle 9 to pass therethrough. When positioned for use, the strip 35 will be placed upon the spindle 9 at a position between the separator 31 and the latch 32, having its outer extremities supported by the support 3 or at some other convenient point, thereby preventing any downward movement of the spindle thereby tending to bend it.

It is obvious that the device is adaptable to journals of any length by simply adding frames, the support 3 being correspondingly long, the support 35 making it possible to employ a long spindle and yet maintaining rigidity, and by reason of the plurality of oiling-disks lubrication can be evenly effected, it being understood that the lower portion of the disks is immersed in oil. As the frames 11 and 12 are weighted upon one end and the lighter end carrying the disks, it is obvious that the said disks will be kept in contact with the journal at all times.

The positions of the various parts as herein shown are merely arbitrary, and they may be changed without departing from the spirit of the invention.

Referring to the modification Fig. 8, the two frame members 36 37 are held together by a projection 38, which is adapted to fit a recess 39 in the other member, thereby forming a dovetail joint, and thus dispensing with the bolt 15, as in the other instance.

What I claim, and desire to cover by Letters Patent, is—

1. A lubricating device adapted for insertion in a journal-box, comprising a support composed of two members pivotally connect-

ed, a spindle fastened to one member of the said support, the free end of the said spindle being carried by the other member of said support, lubricating means carried by said spindle and adapted to bear against a journal within said journal-box.

2. A lubricating device adapted for insertion in a journal-box, comprising a support composed of two members pivotally connected, a spindle fastened to one member of said support, the free end of said spindle adapted to pass through an opening formed in a strip positioned at an angle to the axis of said spindle, the end of said strip being carried by the said support, lubricating means carried by said spindle and adapted to bear against a journal within said journal-box.

3. A lubricating device adapted for insertion in a journal-box, comprising a support composed of two members pivotally connected, a spindle fastened to one member of said support, the free end of said spindle adapted to pass through an opening formed in a detachable strip, the ends of said strip adapted to rest upon said support, means preventing the dislodgment of said strip together with means, carried by said spindle, adapted to lubricate a journal within said journal-box.

4. A lubricating device adapted for insertion in an axle-box, comprising a support composed of two members pivotally connected, one member having attached thereto one end of a spindle, the free end of said spindle passing through an opening formed in a detachable strip, the ends of said strip adapted to rest upon the said support, means preventing the dislodgment of said strip, together with means carried by the spindle adapted to lubricate a journal within said axle-box.

Signed at West New Brighton, in the county of Richmond and State of New York, this the 19th day of April, A. D. 1904.

GEORGE W. PERO.

Witnesses:

E. A. JARVIS,
HENRY J. SEERY.