

Nov. 1, 1938.

J. J. HENZE

2,134,875

GRATE

Filed June 21, 1937

2 Sheets-Sheet 1

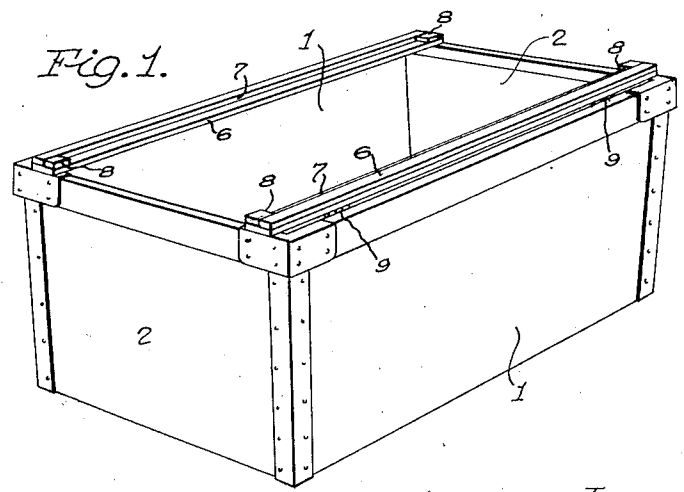
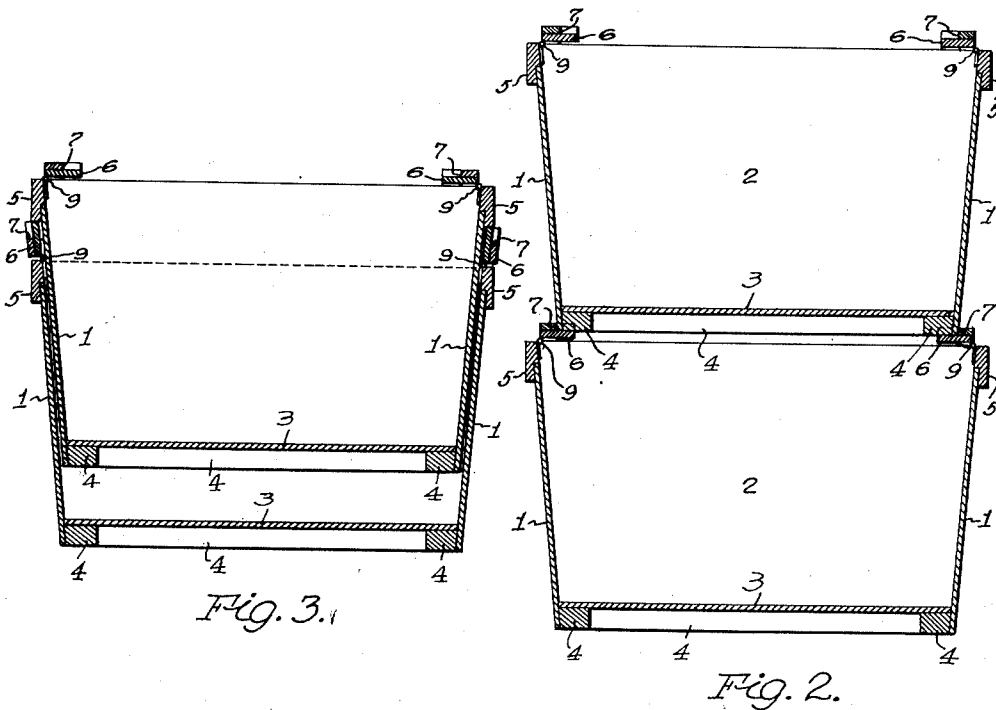

Inventor

Joseph J. Henze,

By

Banker & Smith
Attorneys

Nov. 1, 1938.

J. J. HENZE

2,134,875

CRATE

Filed June 21, 1937

2 Sheets-Sheet 2

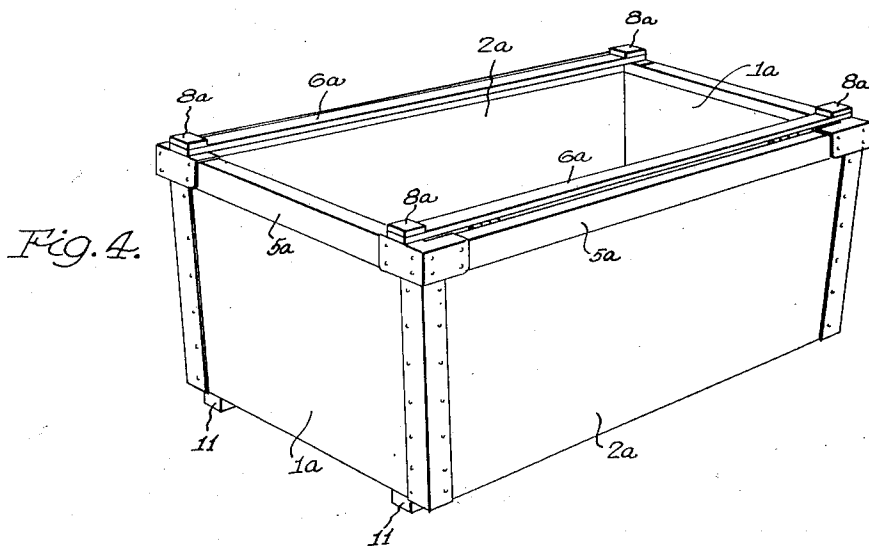
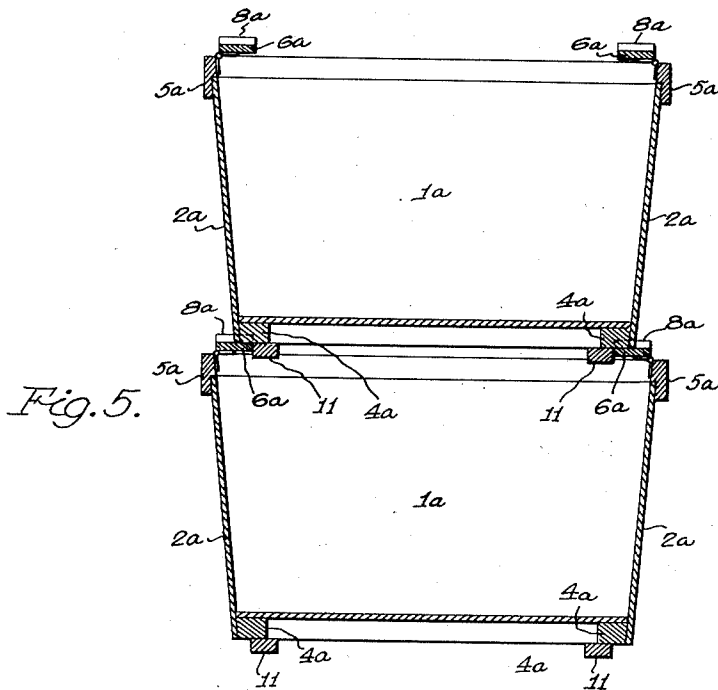

Inventor

Joseph J. Henze,

By

Charles J. Henze
Attorneys

UNITED STATES PATENT OFFICE

2,134,875

CRATE

Joseph J. Henze, Detroit, Mich.

Application June 21, 1937, Serial No. 149,327

4 Claims. (Cl. 220—97)

The present invention relates to shipping crates or boxes and has for its primary object to provide crates or boxes with means whereby they may be stacked one upon another, when filled, and whereby they may be nested, one within another, when empty.

More specifically, the invention has for its object to provide crates or boxes having tapered walls whereby they may be nested one within another when empty and means thereon which functions when the crates or boxes are so nested to prevent them from becoming wedged together. The means which prevents the boxes from wedging comprises narrow flaps or covers, which in one position engage nested crates or boxes to prevent them from wedging, and in another position provide supports whereby the crates or boxes may be stacked one upon another. In the first mentioned position, the flaps or covers extend in the nature of continuations of the side walls of the crates or boxes and the flaps on one crate engage a crate inserted therein to support the same. When in their other mentioned position, the flap or cover members project inwardly of the crate side walls and the flaps or covers on one crate are adapted to be engaged by the bottom of a second crate stacked thereon. When the second crate is so supported it co-operates with the narrow flaps or cover members in substantially completely covering the lower crate.

Another object of the invention is to provide flaps or covers of the character above referred to with means for preventing accidental displacement of a stacked crate therefrom. In the case of crates having a smooth bottom wall or bottom frame the means for this purpose is provided by forming shoulders on the flaps or covers, whereas in the case of crates having slide rails on the bottom thereof, the flaps or covers are constructed to engage the sides of these rails to prevent lateral displacement of a crate from another, and are provided with shoulders which engage the ends of a stacked crate to prevent endwise displacement.

With the above and other ends in view the invention consists in matters hereinafter more particularly pointed out with reference to the accompanying drawings, in which—

Figure 1 is a perspective of a crate;

Fig. 2 is a vertical section of two stacked crates;

Fig. 3 is a vertical section of two nested crates; Fig. 4 is a perspective illustrating the crate with slide rails, and

Fig. 5 is a vertical section illustrating two of the second type of crates in stacked condition.

Like characters of reference are employed throughout to designate corresponding parts.

As shown in Figs. 1, 2 and 3, the crate comprises tapered side and end walls 1 and 2 respectively, and a bottom wall 3 reinforced by the usual frame 4. At their tops, the side and end walls 1 and 2 are reinforced by a frame 5, and it will be noted that the upper edges of the frame 5 are horizontal. Hingedly secured to the side frame members 5 are comparatively narrow flaps or covers 6, provided with lengthwise extending shoulders 7 and transversely extending shoulders 8 at the ends thereof.

The flaps or covers 6 are adapted to be moved, manually, to two alternative positions, one position being shown in Fig. 2 and the other being shown in Fig. 3. As shown in Fig. 2 the flaps or covers project inwardly from the crate side walls and the flaps on one crate provide a support for another crate. When the flaps are projected inwardly, horizontally, they are supported at their ends by engagement with the ends of the crate and between their ends by their hinges 9. A crate, when placed upon the other crate as shown, is prevented from accidental lateral displacement by the shoulders 7, and from endwise displacement by the shoulders 8.

When the flaps or covers 6 are positioned as shown in Fig. 3, the flaps on one crate engage the reinforcing frame members 5 of a crate inserted therein to prevent wedging of the inserted crate in the crate which receives it. In connection with the showing of Fig. 3, it will be understood that the clearance between the flaps or covers and the side frames 5 is exaggerated and that in the crate as built the flaps or covers actually find support on the frames 5, as well as being supported by the hinges.

In the form shown in Figs. 4 and 5 the crate structure is substantially the same as that described above and comprises side and end walls 1a and 2a, bottom frame members 4a, and top frame members 5a. On this crate slide rails 11 are provided on the bottom frame members 4a, and when the flaps or covers 6a are positioned as shown in Fig. 5 the edges thereof engage the slide rails on the crate supported thereby to prevent lateral displacement of the supported crate. The flaps or covers 6a have shoulders 8a at the ends thereof which engage a supported crate to prevent endwise displacement thereof.

Although specific embodiments of the invention have been illustrated and described it will

be understood that various changes may be made within the scope of the appended claims without departing from the spirit of the invention and such changes are contemplated.

5 What I claim is:—

1. In combination with a four-sided crate having tapered walls reinforced at their upper edges by frame members arranged to provide external shoulders, flaps hingedly connected to the inner top edges of the frame members at two opposed sides of the crate with the hinges disposed whereby the flaps may be moved to and held by gravity in a substantially vertical position wherein they constitute a vertical continuation of said side frame members, said flaps being of a length greater than the space between the two remaining side frame members whereby their ends contact said remaining frame members when the flaps are moved to a horizontal position, whereby said remaining frame members support said flaps in a horizontal position.
2. In combination with a four sided crate having tapered walls reinforced at their upper edges by frame members arranged to provide external shoulders, flaps hingedly connected to the inner top edges of the frame members at two opposed sides of the crate with the hinges disposed whereby the flaps may be moved to and held by gravity in a substantially vertical position wherein they constitute a vertical continuation of said side frame members, said flaps being of a length greater than the space between the two remaining side frame members whereby their ends contact said remaining frame members when the flaps are moved to a horizontal position, whereby said remaining frame members support said flaps in a horizontal position, and transverse shoulder members at opposite ends of said flaps.

3. In combination with a four sided crate having tapered walls reinforced at their upper edges by frame members arranged to provide external shoulders, flaps hingedly connected to the inner top edges of the frame members at two opposed sides of the crate with the hinges disposed whereby the flaps may be moved to and held by gravity in a substantially vertical position wherein they constitute a vertical continuation of said side frame members, said flaps being of a length greater than the space between the two remaining side frame members whereby their ends contact said remaining frame members when the flaps are moved to a horizontal position, whereby said remaining frame members support said flaps in a horizontal position, and longitudinally extending shoulders on the upper surfaces of said flaps.

4. In combination with a four sided crate having tapered walls reinforced at their upper edges by frame members arranged to provide external shoulders, flaps hingedly connected to the inner top edges of the frame members at two opposed sides of the crate with the hinges disposed whereby the flaps may be moved to and held by gravity in a substantially vertical position wherein they constitute a vertical continuation of said side frame members, said flaps being of a length greater than the space between the two remaining side frame members whereby their ends contact said remaining frame members when the flaps are moved to a horizontal position, whereby said remaining frame members support said flaps in a horizontal position, longitudinally extending shoulders on the upper surfaces of said flaps, and transverse shoulders at opposite ends of said flaps.

JOSEPH J. HENZE.