

J. LUMSDEN.  
SAW MITERING DEVICE.

No. 512,561.

Patented Jan. 9, 1894.

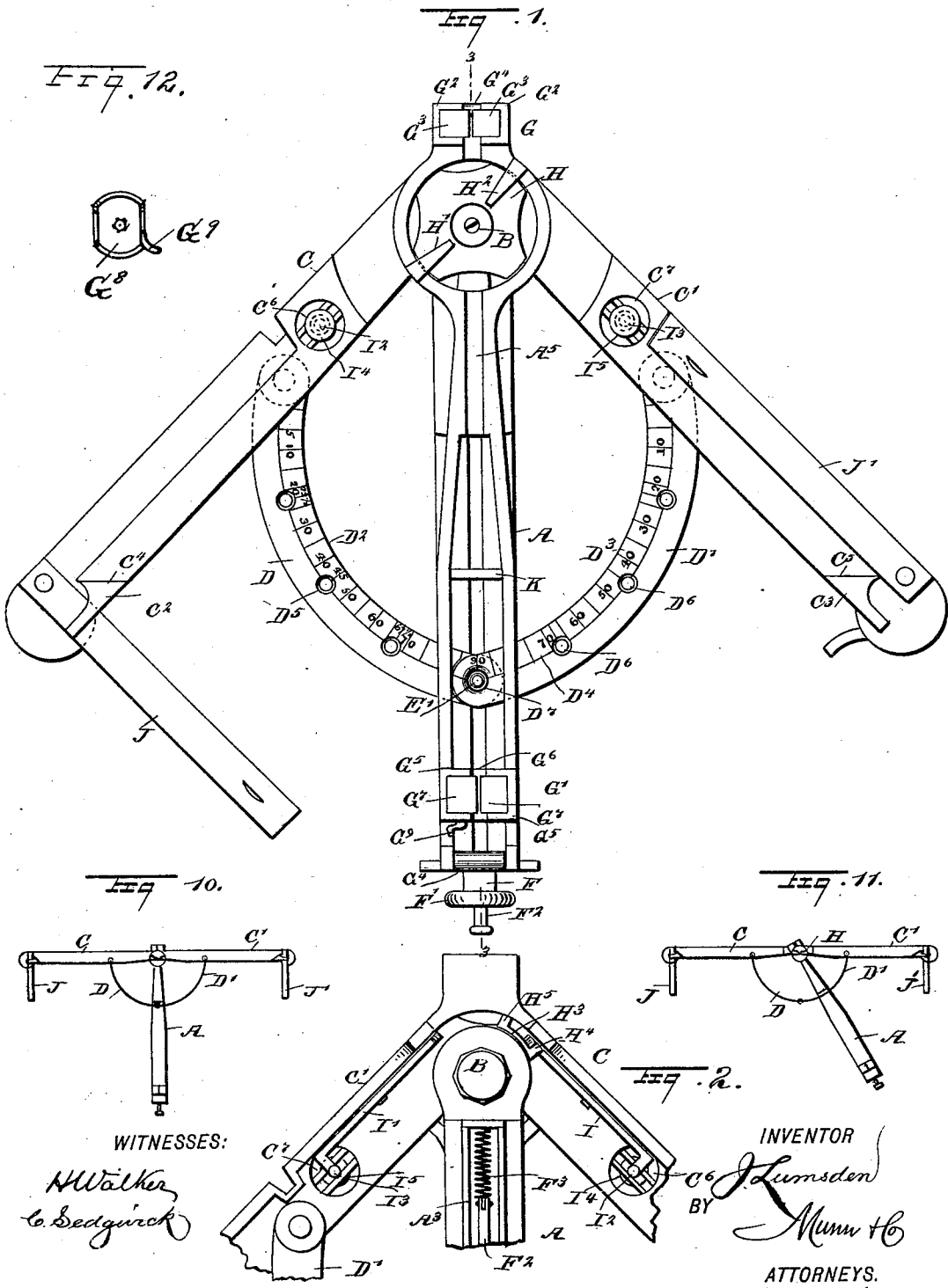

WITNESSES:  
*N. Walker*  
*Co. Sedgwick*

INVENTOR  
*J. Lumsden*  
 BY *Munn & Co.*  
 ATTORNEYS.

J. LUMSDEN.  
SAW MITERING DEVICE.

No. 512,561.

Patented Jan. 9, 1894.

FIG. 3.

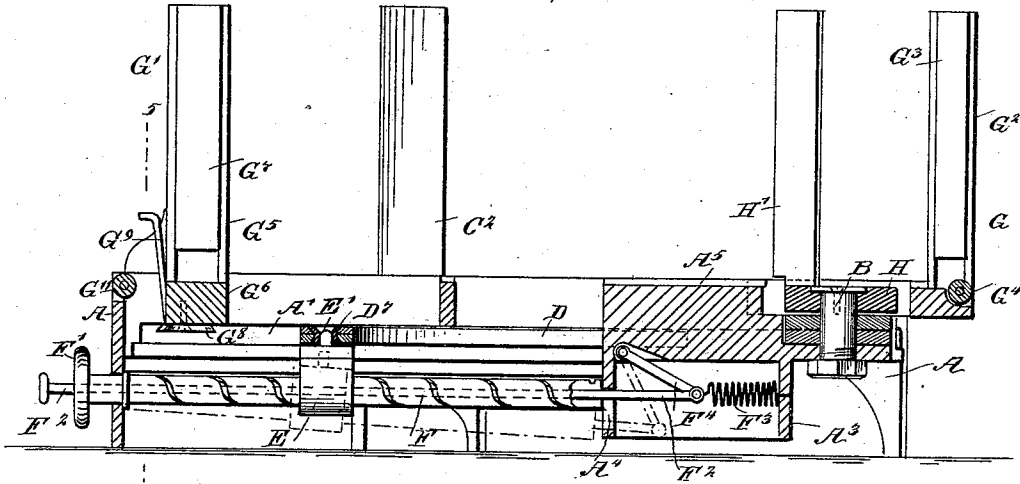

FIG. 4.

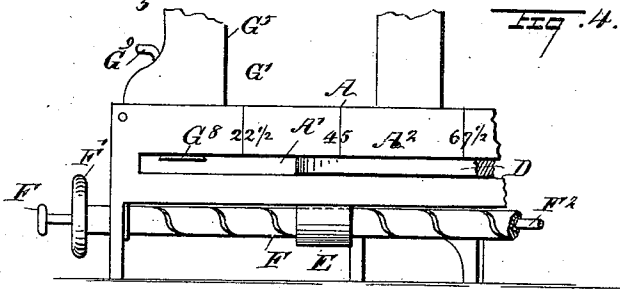

FIG. 5.

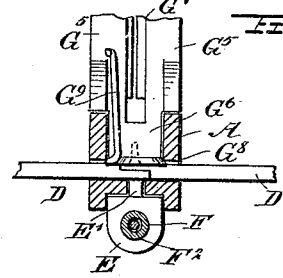

FIG. 6.

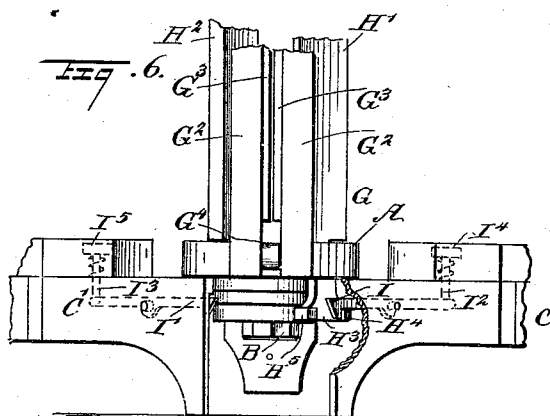

FIG. 7.

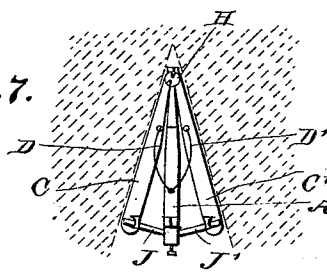

FIG. 8.

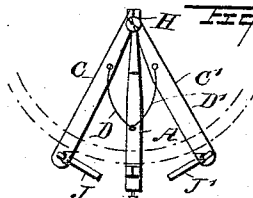
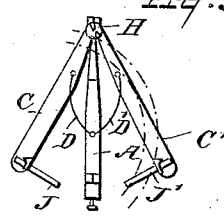

FIG. 9.



WITNESSES:

*H Walker*  
*C Sedgwick*

INVENTOR

*J Lumsden*  
BY *Munn & Co*

ATTORNEYS.

# UNITED STATES PATENT OFFICE.

JAMES LUMSDEN, OF NEW ROCHELLE, NEW YORK.

## SAW-MITERING DEVICE.

SPECIFICATION forming part of Letters Patent No. 512,561, dated January 9, 1894.

Application filed March 7, 1893. Serial No. 464,944. (No model.)

*To all whom it may concern:*

Be it known that I, JAMES LUMSDEN, a subject of the Queen of Great Britain, at present residing at New Rochelle, in the county of Westchester and State of New York, have invented a new and Improved Saw-Mitering Device, of which the following is a full, clear, and exact description.

The object of the invention is to provide a new and improved saw mitering device designed for general use by mechanics, and arranged to enable the mechanic to make square cuts or any desired angular cut, and to take the angle in panel and other work, to make the beveled cut corresponding to the bisection of the angle of the panel.

The invention consists of a saw guide frame, supporting bars arranged on opposite sides of the said guide frame and pivoted thereto, and arms pivotally connected with the said side bars to connect with a block mounted to slide in the said guide frame.

The invention also consists of certain parts and details, and combinations of the same, as will be hereinafter described and then pointed out in the claims.

Reference is to be had to the accompanying drawings, forming a part of this specification, in which similar letters of reference indicate corresponding parts in all the figures.

Figure 1 is a plan view of the improvement as arranged for a miter cut. Fig. 2 is an inverted plan view of part of the same. Fig. 3 is a sectional side elevation of the same on the line 3—3 of Fig. 1. Fig. 4 is a side elevation of part of the saw guide frame. Fig. 5 is a sectional front elevation of the same on the line 5—5 of Fig. 3. Fig. 6 is a rear end elevation of the improvement with parts in section, showing the locking device for the center timber rest; and Figs. 7, 8, 9, 10 and 11, show diagrammatic plan views of the device as applied for various purposes. Fig. 12 is a plan of the device for locking one of the saw guides on the guide frame.

The improved device is provided with a saw guide frame A mounted on suitable legs and carrying at one end, a pivot B, on which are pivoted the side bars C and C', arranged on opposite sides of the guide frame A, likewise provided with legs, so that the top surfaces of the bars and guide frame A extend

in the same horizontal plane. The side bars C and C' are pivotally connected at their under sides and near the middle with the segmental arms D and D', pivotally connected with each other at their overlapping ends by a perforated pivot D', engaged by a pin E' formed on a block E mounted to slide longitudinally on the guide frame A, the said block forming a nut and screwing on a screw rod F arranged under the saw guide frame A. On the outer end of the screw rod is provided a knob or handle F', for conveniently turning the said screw rod F, so as to move the block E longitudinally to cause its pin E' to carry the arms D and D' along, so as to open or close the side bars C and C', that is, move the latter nearer to or farther from the sides of the guide frame A, the movement being simultaneous and equal so that the side bars always stand at like angles to the saw guide frame A.

In order to indicate the angle on which the side bars C and C', are set relative to the frame A, I provide the side of the latter with a graduation A<sup>2</sup>, indicating degrees, see Fig. 4, and on which graduation indicates a segmental line D<sup>4</sup> forming part of the graduation D<sup>3</sup> arranged on the top surface of the arm D', and indicating degrees and subdivisions of the same. (See Fig. 1.) A like graduation in degrees D<sup>2</sup> is arranged on the top surface of the other arm D to indicate the relative positions of the guide frame A. Thus, when the device is in the position as shown in Fig. 1, for instance, the line D<sup>4</sup> on the arm D', registers with the forty five degree line of the graduation A<sup>2</sup>, thus indicating that the bars C and C' are set at an angle of forty five degrees to the saw guide frame A and at an angle of ninety degrees, one to the other.

The screw rod F is made hollow and through it passes a rod F<sup>2</sup> projecting a suitable distance beyond the knob F' at the outer end of the screw rod F and also projecting a suitable distance beyond the inner end of the said screw rod, as plainly shown in Fig. 3. This inner end of the rod F<sup>2</sup> is connected with one end of a spring F<sup>3</sup> held in a casing A<sup>3</sup> arranged on the under side of the saw guide frame A. A link F<sup>4</sup> is pivotally-connected with this inner end of the rod F<sup>2</sup>, the said link F<sup>4</sup> being pivotally-connected with the

top of the casing A<sup>3</sup>, as shown in the said Fig. 3. The rod F<sup>2</sup> is guided in a vertically disposed slot A<sup>4</sup>, formed in one end of the casing A<sup>3</sup>, the screw rod F terminating at the front face of the said end, so that the rod F<sup>2</sup> forms part of the bearing for the screw rod F, the latter having only a bearing in the outer end of the saw guide frame A. This bearing is somewhat loose, so as to permit the screw rod F to swing downward, which swinging is accomplished by pulling on the outer end of the rod F<sup>2</sup>, so as to cause the link F<sup>4</sup> to swing the inner end of the said rod downward, thus carrying the screw rod F in the same direction (see dotted lines, Fig. 3), thereby moving the block E in the same direction and disengaging the pin E' from the inner, overlapped pivoted ends of the arms D and D'. When the operator releases the pressure on the outer end of the rod F<sup>2</sup>, then the spring F<sup>3</sup> pulls the rod back to its normal position to move the screw rod F upward to permit the pin E' to again engage the arms D and D', as shown. The pin E' is disengaged from the arms D, D', for the purpose of swinging the saw guide frame A into an angular position relative to the side bars C and C', at the time the latter stand in alignment with each other, as plainly illustrated in Fig. 11. When the pin E' is disengaged from the pivotal connection of the arms D, D', then the saw guide frame A can be swung sidewise onto either of the arms D, D', so that the pin E' is free to engage apertures D<sup>5</sup> and D<sup>6</sup> formed in the arms D, D', as plainly shown in Fig. 1, it being understood that the screw rod F is turned to the right or left to move the block E inward or outward, to bring the pin E' in engagement with one of the said apertures D<sup>5</sup> in the arm D, or one of the apertures D<sup>6</sup> in the arm D'. In this manner the saw guide frame A may be swung into any angular position relative to the corresponding side bars C or C', the degree of the angle being indicated by the graduation D<sup>2</sup> or D<sup>3</sup>.

By reference to Fig. 11, the position of the saw guide frame relative to the side bar C', is shown, it being understood that the saw guide frame A has been moved to the right onto the arm D'. The side guide bars C and C' are then extended in alignment one with the other, at an angle of one hundred and eighty degrees, with the saw guide frame A at an angle of forty-five degrees to the side bar C', it being understood that the degree on the graduation D<sup>3</sup> is read off from the right side of the saw guide frame A. If the latter is moved over the other arm D, then the degree is read off from the graduation D<sup>2</sup>, at the intersection of the left side of the frame A, with the corresponding mark on the said graduation D<sup>2</sup>.

On the top of the saw guide frame A are arranged the saw guides G and G' of which the saw guide G is provided with two vertically disposed casings G<sup>2</sup>, open at their opposite faces and also on top, and formed inte-

gral with one end of the saw guide frame. In the casing G are set wooden blocks G<sup>3</sup>, having their adjacent faces a sufficient distance apart to form a slot for the blade of the saw used for cutting the bevels and miters, as hereinafter more fully described. Below the wooden blocks G<sup>3</sup> is journaled a roller G<sup>4</sup>, adapted to form a rest for the teeth of the saw in case the latter should be moved too far down after the cut has been made. The other saw guide G' is similarly provided with two casings G<sup>5</sup>, connected with each other, however, on the under side by a cross piece G<sup>6</sup> fitted to slide longitudinally in a suitable guideway arranged in the top of the saw guide frame A. In the casings G<sup>5</sup> are arranged wooden blocks G<sup>7</sup>, similar to the wooden blocks G<sup>3</sup>, and also forming a slot which is in alignment with the slot of the saw guide G and in a plane passing through the said slot of the saw guide G and the center of the pivot B. See Fig. 1.

In order to fasten the second saw guide G' in place on the saw guide frame A, I provide a cam plate G<sup>8</sup> pivoted to the under side of the cross piece G<sup>6</sup>, and adapted to be swung in a longitudinally extending groove A', formed transversely in the guide frame A, and through which pass the ends of the arms D, D', as plainly shown in Figs. 3 and 4. The plate G<sup>8</sup> is preferably beveled at its edge, and is adapted to be turned by means of an upwardly extending handle G<sup>9</sup>, adapted to be taken hold of by the operator to turn the plate G<sup>8</sup>, so as to move the same in or out of the slot A' to lock or unlock the saw guide G'. When the latter is unlocked, it can be conveniently moved forward or backward in the saw guide frame A, to suit the length of the saw used for cutting the bevels and miters, and also to increase or diminish the distance between the two saw guides G and G', according to the article to be cut, and resting on the top surface of the guide frame A and the bars C and C'. At the outer end of the saw guide frame A, in the rear of the saw guide G', is arranged a second roller G<sup>11</sup> in alignment with the other roller G<sup>4</sup> and extending with its top surface to the top surface of the guide frame A. The inward sliding motion of the saw guide G' is limited by a stop K, arranged in the saw guide frame A as shown in Fig. 1.

In order to make a full and clean cut by the saw, I arrange in the top of the saw guide frame A longitudinally extending recesses A<sup>5</sup>, in alignment with the slots of the saw guides G and G', so that the block to be sawed can be cut completely through without danger of sawdust working under the block, as the sawdust will fall into a longitudinal recess A<sup>5</sup>.

On the pivot B is arranged a center rest comprising a disk H mounted to turn loosely on the pivot B and provided with upwardly extending posts H<sup>1</sup> and H<sup>2</sup> having their front faces located diametrically opposite each other, as plainly shown in Fig. 1. From the disk H, extends downward an arm H<sup>3</sup>, fitting

over the pivot ends of the side bars C and C' (see Fig. 6), and on this arm H<sup>3</sup> are arranged lugs H<sup>4</sup> and H<sup>5</sup> adapted to be engaged by hooks I and I', respectively, pivoted to the side bars C and C', respectively, at the under side thereof, as illustrated in said Fig. 6, and also in Fig. 2. On the ends of the hooks I and I', are arranged upwardly extending pins I<sup>2</sup> and I<sup>3</sup>, respectively, extending into recesses C<sup>6</sup> and C<sup>7</sup>, respectively, formed in the top of the side bars C and C', the upper ends of the said pins carrying knobs I<sup>4</sup> and I<sup>5</sup>, respectively, adapted to be pressed on by the operator, so as to throw the corresponding hook I or I' out of contact with the respective lug H<sup>4</sup> or H<sup>5</sup>. The pins I<sup>2</sup> and I<sup>3</sup> are pressed on by springs resting in the recesses C<sup>6</sup> and C<sup>7</sup> so that the hooks I and I' are held in normal positions; that is, the respective hook in engagement with the corresponding lug H<sup>4</sup> or H<sup>5</sup>. When the operator presses say the knob I<sup>4</sup>, at the time the hook I engages the lug H<sup>4</sup>, as shown in Fig. 6, then the said hook disengages the lug H<sup>4</sup> to permit the operator to turn the center rest, the disk H of the same then turning on the pivot B. When a half turn has been given to the disk H, then the lug H<sup>5</sup> engages the hook I', so that the center rest is again locked in place to prevent a return movement of it, the front faces of the posts H' and H<sup>2</sup> then standing at right angles to their former position. The inner edges of the posts H' and H<sup>2</sup> terminate a suitable distance from the center of the pivot B, so that the saw blade extending through the saw guides G and G', clears, at all times, the inner edges of the said posts.

On the outer ends of the side bars C and C', are arranged the rear rests C<sup>2</sup> and C<sup>3</sup>, respectively, having their front faces C<sup>4</sup> and C<sup>5</sup>, respectively, in alignment with each other at the time the bars C and C' stand at right angles to each other, as plainly shown in Fig. 1. The inner faces of the said rests C<sup>2</sup> and C<sup>3</sup>, are in alignment with the inner faces of the side bars, as shown. Now when the device is in the position, as illustrated in Fig. 1, the block of wood to be sawed can be rested against the faces C<sup>4</sup> and C<sup>5</sup>, and when the cut is made by the saw blade passing through the guides G and G', then a straight cut is produced on the block. On the outer ends of the side bars C and C' are pivoted extension legs J and J', respectively, adapted to be either folded on top of the respective side bars or extended at right angles thereto, as illustrated in Fig. 1, the said figure showing but one extension leg J in a right angular position, while the other extension leg J' is folded on its side bar C'. When the device is in this position and a block of wood is placed on the extension leg J to rest against the inner face of the rest C<sup>2</sup> and on the front faces of the posts H' and H<sup>2</sup>, the operator will make a miter cut, it being understood that the saw is guided in the saw guides G and G', as above described. When it is desired to make an an-

gular cut in the opposite direction, then the center rest is turned as above described, to bring the faces of the posts H' and H<sup>2</sup> in alignment with the inner face of the post C<sup>3</sup>, the leg J' then being extended into right angular position relative to the bar C'.

The device is used as follows: When the several parts are in the position as illustrated in Fig. 1, then the pin E' is in engagement with the apertured pivot connecting the arms D and D' with each other in the center of the saw guide frame A. Now, by turning the knob E' to the right or left, the block E is caused to slide outward or inward in its bearing on the saw guide frame A, so that the arms D and D' exert a pull or push on the saw guide bars C and C', thus moving the latter simultaneously and equal distances toward or from the saw guide frame A, so that the said side bars assume any desired angle relative to the saw guide frame A, the degree being read off from the graduation A<sup>2</sup>, as previously explained. In the position illustrated in Fig. 1, the side bars C and C', stand at right angles to each other and consequently at an angle of forty-five degrees to the saw guide frame A. When a block of wood is placed on top of the side bars C, C', and across the frame A, with the block resting against the faces C<sup>4</sup> and C<sup>5</sup>, of the rests C<sup>2</sup> and C<sup>3</sup>, respectively, then the operator by moving the saw in the usual manner through the saw guides G, G', makes a square cut in the block of wood. When the operator takes the block of wood and places it across the extended leg J' and the side bar C' and frame A with the block resting against the front faces of the rests H' H<sup>2</sup>, of the center rest, and the inner face of the rest C<sup>2</sup>, then a forty-five degree cut in the block of wood can be made, it being understood that the saw is guided in the guides G and G'. Now, when it is desired to make a forty-five degree bevel on the block in an opposite direction, the operator extends the leg J', as previously described, and gives the center rest G a half turn, by first pressing the knob I<sup>4</sup> to disengage the hook I from the lug H<sup>4</sup> to permit of turning the center rest until the other hook I' engages the lug H<sup>5</sup> and again locks the center rest in place. The faces of the rests H' and H<sup>2</sup> are then in alignment with the inner faces of the rest C<sup>3</sup>, and a block of wood placed across the leg J', the saw guide A and guide bar C, and pressed against the said registering faces, permits the operator to make a forty-five degree cut, the saw being guided in the saw guides G and G'. A straight cut can also be made by extending the side bars C and C' to an angle of one hundred and eighty degrees, that is, in alignment one with the other, as shown in Figs. 10 and 11, the legs J' with the saw guide frame A, then forming the rest for the block of wood, which is pressed against the registering faces of the rests C<sup>2</sup>, C<sup>3</sup>, and the rests H', H<sup>2</sup>, of the center rest H.

It is understood that when the screw rod F

is turned and the side bars C and C' are caused to swing inward or outward, as above described, then the respective hook I or I', by being in contact with the corresponding lug H<sup>4</sup> or H<sup>5</sup>, causes a turning of the center rest H to open or close the rests H' or H<sup>2</sup> relative to the saw passing through the saw guides G and G'. Thus, when the side bars C and C' are fully extended or in their outermost position, the front faces of the rests H' and H<sup>2</sup> stand at right angles to the center line of the saw guide frame A.

When it is desired to make bevels, say for panel work, then the device is applied in the manner shown in Fig. 7, that is, the entire apparatus is used to take the angle of the panel and then, after this has been done, the bevels are cut on the device to obtain a proper fitting. For this purpose the device is placed in the angle as shown in Fig. 7, with the pivot end B toward the apex of the panel angle, and then the screw rod F is turned to bring the outer edges of the bars C and C' in contact with the sides of the angle, so that the angle of the side bars is that of the panel. When the angle has thus been obtained, the operator places the device on the bench and then arranges the blocks of wood to be fitted into the said panel angle on the instrument, the first block being placed against the rest C<sup>2</sup>, and center rest, and the cut then made; then the center rest is given a half turn as above described, and the block to be joined is placed against the center rest and the other rest C<sup>3</sup>, and a bevel made by the saw in the saw guides G and G'. In this manner the two bevels made will join in the angle of the panel.

When it is desired to miter segmental blocks, as shown in Figs. 8 and 9, then the segmental block is placed against the edges of the rests C<sup>2</sup>, C<sup>3</sup>, (see Fig. 8,) and when the saw is used in the saw guides G and G' to cut the block, then the cut is radial, irrespective of the size of the radius of the segmental block, it being understood, however, that the center of the segmental block must be in a line passing through the slots of the saw guides G and G', that is, in the center line of the saw guide frame A. In a like manner these segmental blocks may be placed between the corresponding rests C<sup>2</sup>, H', or C<sup>3</sup>, H<sup>2</sup>, for mitering circular work, as shown in Fig. 9, with the block projecting across the inner end of the saw guide frame A at the point where the cut is to be made.

In case the saw guide frame A is swung onto either of the arms D, D', and the pin E' does not register with an aperture at the desired angle between the corresponding side bars C or C', and the saw guide frame A, then the operator can lock the saw guide frame A in place on the corresponding arms D and D', by turning the screw rod F to the right to move the pin E' to the outer edge of the corresponding segmental arm D or D', so that the said pin presses against the edge of

the arm with sufficient force to lock the saw guide frame A to the said arm, the angle of course, being read off at the intersection of the corresponding side of the saw frame A on the graduation D<sup>2</sup> or D<sup>3</sup>. The device may also be used for other purposes.

Having thus fully described my invention, I claim as new and desire to secure by Letters Patent—

1. A saw mitering device comprising two side bars pivoted to each other and capable of being brought into longitudinal alignment, arms pivotally connected with the side bars and with each other and provided with a series of spaced apertures, a guide device capable of a sliding movement longitudinally of the saw guide frame and adapted for detachable engagement with the said apertures of the arms, the frame with the guide being movable laterally in relation to the side bars, substantially as described.

2. A saw mitering device, comprising a saw guide frame supporting the saw guides, side bars pivotally connected with the said saw guide frame, means for moving the said side bars simultaneously and equal distances toward or from the said saw guide frame, and a center rest mounted to turn on the pivot for the said side bars, substantially as shown and described.

3. A saw mitering device, comprising a saw guide frame carrying the saw guides, side bars pivotally connected with the said saw guide frame and arranged on opposite sides of the same, each of the said side bars being provided with a rest for the material to be cut, and a center rest mounted to turn on the pivot for the said side bars and adapted to turn with the said side bars, substantially as shown and described.

4. A saw mitering device, comprising a saw guide frame carrying the saw guides, side bars pivotally connected with the said saw guide frame and arranged on opposite sides of the same, each of the said side bars being provided with a rest for the material to be cut, a center rest mounted to turn on the pivot for the said side bars and adapted to turn with the said side bars, and means, substantially as described, for locking the said center rest to either of the said side bars to cause the center rest to turn with the side bars, as set forth.

5. A saw mitering device, comprising a saw guide frame carrying the saw guides, side bars pivotally connected with the said saw guide frame and arranged on opposite sides of the same, each of the said side bars being provided with a rest for the material to be cut, a center rest mounted to turn on the pivot for the said side bars and adapted to turn with the said side bars, and means, substantially as described, for unlocking the said center rest to permit of turning the same by hand on its pivot, as set forth.

6. A saw mitering device, comprising a saw guide frame carrying the saw guides and sup-

porting near one end a pivot, side bars mounted to swing on the said pivot and provided on their outer ends with rests for the material to be cut, segmental graduated arms pivotally connected with each other and with the said side bars and provided with a series of spaced openings, a block mounted to slide longitudinally on the said saw guide frame and provided with a pin adapted to engage the openings of the said segmental arms, and a screw rod mounted to turn screwing in the said block to move the latter longitudinally on the said saw guide frame, a spring-pressed rod adapted to slide in the said screw rod, and a link pivotally connected with the said rod and the saw guide frame, whereby the pin of the block is disengaged from the segmental arms when the spring-pressed rod is operated, substantially as shown and described.

7. A saw mitering device, comprising a saw guide frame, carrying the saw guides and supporting near one end a pivot, side bars mounted to swing on the said pivot and provided on their outer ends with rests for the material to be cut, segmental graduated arms pivotally connected with the said side bars, a block mounted to slide longitudinally on the said saw guide frame and pivotally connected with the said segmental arms, a screw rod mounted to turn and screwing in the said block to move the latter longitudinally on the said saw guide frame, and a device for disengaging the said block from the said segmental arms, substantially as shown and described.

JAMES LUMSDEN.

Witnesses:

THEO. G. HOSTER,  
C. SEDGWICK.