



Europäisches Patentamt
European Patent Office
Office européen des brevets

Publication number:

**0 260 435
A1**

EUROPEAN PATENT APPLICATION

Application number: 87111611.7

Int. Cl. 4: **E 04 C 2/38**

Date of filing: 11.08.87

Priority: 15.08.86 CH 3290/86

Applicant: **THE DOW CHEMICAL COMPANY, 2030 Dow Center Abbott Road P.O. Box 1967, Midland, MI 48640 (US)**

Date of publication of application: 23.03.88
Bulletin 88/12

Inventor: **Deblander, Jean-Philippe Jacques, Untermattstrasse 14, CH-8805 Richterswil (CH)**

Designated Contracting States: **AT BE CH DE ES FR GB IT LI NL SE**

Representative: **Sternagel, Hans-Günther, Dr. et al, Patentanwälte Dr. Michael Hann Dr. H.-G. Sternagel Sander Aue 30, D-5060 Bergisch Gladbach 2 (DE)**

Composite building panels.

The composite building element comprises a core panel 1 of a rigid foamed material of an expanded synthetic resin and two stiff frames 3, 5 of essentially the same length and the same width as the length and width of the core panel 1. The stiff frames 3, 5 are bonded to the back and front surface 2, 12 of the core panel 1.

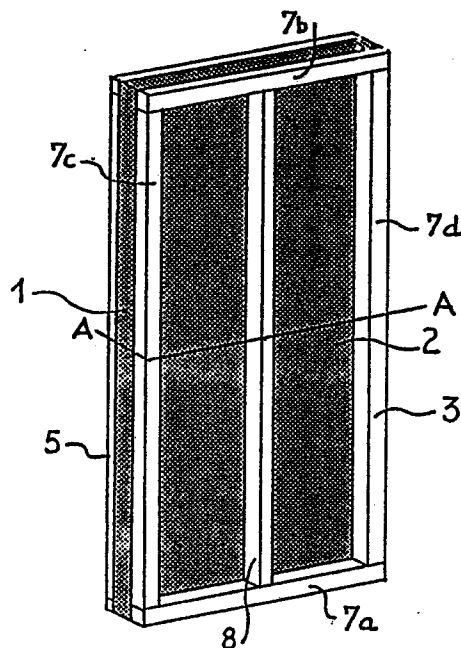

COMPOSITE BUILDING PANEL

The present invention relates to composite building elements and in particular to composite building panels which have various applications in the building industry, for example for building walls, floors, ceilings and roofs.

One popular method of building a wall is to build a timber frame which is then filled with glass wool. Since these timber frames are not highly shear resistant, a plywood sheathing is usually nailed to the timber frame. However, the plywood sheathing is relatively expensive and it does not always provide the building element with sufficient shear resistance. Insufficient shear resistance is also experienced when a chip board is nailed to the timber frame instead of plywood. The use of a chip board is furthermore disadvantageous because of the excessive weight of the chip board which is required to obtain satisfactory strength.

In GB patent specification 1 587 012 it is suggested to close a wall space defined by the timber frames of a building with a foamed polyurethane or a foamed polystyrene. However, such timber frames of which the wall space is filled with foamed polyurethane or polystyrene sheets have several disadvantages when building the walls. First, the size of the frame and of the foam sheet or slab must be very well adjusted to each other in order to avoid gaps between the frame and the foam sheet or slab. Special seals have been suggested in GB patent specification 1 587 012 in order to fill such difficult to avoid gaps, but such seals increase the installation costs. Furthermore, the timber frame has much lower insulation properties than the foam

sheet or slab and therefore forms thermal bridges in the building panel.

In DE-A-2816935 (equivalent to US-A-4193244) a module block is disclosed which consists of two parallel fiber plates. To each fiber plate two parallel laths are fixed. For connecting the two fiber plates with each other, side plates, for example fiber plates or chip boards, are fixed to the laths perpendicularly to the first two fiber plates. Between the four plates, an insulation material such as rock-wool is placed. However, fiber-plates, ply-wood or chip boards of heavy weight are required for providing sufficient shear strength to the module block. Furthermore, the side plates produced of fiber plates, chip board or ply-wood boards have insufficient insulation properties and therefore form thermal bridges in the module block.

Therefore, it is desirable to provide a composite building element which does not only have good insulation properties but also high strength, in particular high shear resistance. It is also desirable to provide a building element which can be prefabricated and easily installed and which preferably has a relatively low weight.

The present invention provides a composite building element which comprises

- a) a core panel of a rigid foamed material of an expanded synthetic resin and
- b) two stiff frames of essentially the same length and the same width as the length and width of the core panel which frames are bonded to the back and front surface of the core panel.

The composite building element of the present invention has a surprisingly high resistance to shearing forces.

Furthermore, the composite building element of the present invention does not provide thermal bridges.

Fig. 1 illustrates a back perspective view on a first embodiment on the composite building element of the present invention.

Fig. 2 illustrates a front perspective view on the first embodiment on the composite building element.

Fig. 3 represents a schematic illustration of the cross-section of the composite building element along line A-A in Figs. 1 and 2.

Fig. 4 to 7 are schematic illustrations of the cross-section of further embodiments of the composite building element of the invention.

The composite building element of the present invention will be further described with reference to the drawings.

With reference to Fig. 1, the composite building element comprises a core panel 1 of a rigid foamed material of an expanded synthetic resin, such rigid foamed polyurethane or rigid foamed polystyrene. Preferably, the core panel 1 is a rigid extruded polystyrene panel which has a density of from 20 kg/m³, preferably of from 30 kg/m³, to 60 kg/m³, preferably to 50 kg/m³. Most preferably, the core panel is moisture resistant. The thickness of the core panel 1 depends on the desired insulating properties and strength of the building element. Preferably, the thickness is from 30 mm to 200 mm, most preferably from 50 mm to 120 mm. The length and width of the panel is not critical. Usual lengths are from 2 to 6 m, preferably from 2 to 3 m. Usual widths are from 0.6 to 12 m, preferably from 1 to 5.

A stiff back frame 3 and a stiff front frame 5 are fixed to the back surface 2 and front surface of the core panel 1. The frames 3, 5 have essentially the same length and same width as the length and width of the core panel 1, however, it is not necessary that the length and width of the frames 3, 5 are exactly the same as those of the core panel 1. The back frame 3 consists of a first set of at least two parallel laths 7a, 7b and a second set of at least two parallel laths 7c, 7d which are perpendicular to the laths 7a, 7b. As illustrated by Fig. 1, the back frame 3 can be subdivided by one or more additional laths 8 which are preferably parallel to the main laths 7c, 7d. The laths 7a, 7b, 7c, 7d and 8 can be produced of any sufficiently strong and stiff material to resist forces which are applied perpendicularly to the smallest cross-section of the back frame 3, i.e. to the cross-section along line A-A and perpendicularly to the plane defined by the back frame 3. Usual materials are for example wood, metal, concrete or hard plastic materials. If the back frame 3 is produced of wood, the main laths 7a, 7b, 7c, 7d have preferably a cross-section of from 20 x 20 mm to 150 x 150 mm, most preferably of from 50 x 50 mm to 100 x 100 mm. The additional lath 8 can have the same cross-section. In general, the cross-section of the additional lath 8 is smaller, for example from 20 x 20 mm to 80 x 80 mm, preferably from 25 x 25 mm to 50 x 50 mm. Fig. 1 illustrates that the back frame 3 and the front frame 5 are not in contact with each other. Therefore, the composite building element of the present invention does not provide the undesired thermal bridges through the thickness of the building element. The back frame 3 and front frame 5 can be fixed to the core panel 1 in any suitable means, preferably by applying an adhesive such as a polyurethane adhesive between the adjacent surfaces of the back frame 3 and the

core panel 1 and between the adjacent surfaces of the front frame 5 and the core panel 1.

The main back laths 7a, 7b, 7c, 7d and optionally the additional back lath 8 can be fixed to each other by any suitable means to build the back frame 3 such as nailing or gluing.

If desired, the corners of the back frame 3 can be reinforced, for example by metal plates which are fixed to the corners of the back frame 3 and to the core panel 1.

Fig. 2 illustrates the same embodiment of the composite building element of the present invention as Fig. 1, however, Fig. 2 represents a perspective front view on the building element. Fig. 2 illustrates a core panel 1 as described with reference to Fig. 1. A stiff front frame 5 is fixed to the front surface 12 of the core panel 1. The front frame 5 is built of a first set of at least two parallel laths 9a, 9b and a second set of at least two parallel laths 9c, 9d which are perpendicular to the first set of laths 9a, 9b. The frame consisting of the main laths 9a, 9b, 9c, 9d can be subdivided by one or more optional additional front laths 10. The front laths 9a, 9b, 9c, 9d and 10 can have the same dimension as the back laths 7a, 7b, 7c, 7d and 8 described with reference to Fig. 1. Cut out along the edges of the front surface 12 of the core panel 1 are rabbets (see 14a and 14b in Fig. 3) which have essentially the same widths and depths as the widths and thickness of the main front laths 9a, 9b, 9c, 9d. The front surface 12 of the core panel 1 is further provided with a groove (see 16 in Fig. 3) extending parallel to the edges of the core panel 1 and which has essentially the same dimensions as the cross-section of the additional front lath 10. The front laths 9a, 9b, 9c, 9d and 10 are placed

in these rabbets and this groove and fixed to the core panel 1.

As an alternative or in addition to the rabbets and groove(s) in the front surface 12 of the core panel 1, the back surface 2 of the core panel 1 can be provided with rabbets and/or one or more grooves.

Fig. 1 and 2 illustrate composite building elements of rectangular shape. In some cases however, it may be desirable that the core panel does not have a rectangular back or front surface but that it has surfaces of a triangular or trapezoid shape. Such shapes are for example preferred when building the portion of a wall which will be in contact with a sloped roof. In such a case, the two stiff frames are adjusted to the shape of the core panel. In one embodiment of the frames, each frame consists of one set of at least two parallel laths, a lath which is perpendicular to this set of parallel laths and one lath which is neither parallel nor perpendicular to this set of parallel laths.

Fig. 3 illustrates a cross-section along the line A-A in Figs. 1 and 2. Fig. 3 illustrates how the main back laths 7c, 7d and the additional back lath 8 are arranged on the back surface 2 of the core panel 1. The front surface 12 of the core panel 1 is provided with rabbets 14a, 14b and with a groove 16. The main front laths 9c, 9d and the additional front lath 10 are placed in these rabbets 14a, 14b and the groove 16 respectively and fixed to the core panel 1.

Fig. 4 illustrates how the composite building panel described with reference to Fig. 3 can be combined with other materials to build a complete wall. An interior finishing layer 20, for example a wood sheet or a gypsum plaster

board is attached to the main back laths 7c, 7d and to the additional lath 8 as well as to the main back laths 7a, 7b (not shown). Thereby a space 22 is built which allows any pipes and electric cables to be fit into the building element in a convenient way. The front surface 12 of the core panel 1 is covered with an external rendering 24.

Fig. 5 illustrates a cross-section through another embodiment of the composite building element of the present invention. The main front laths 9e, 9f, the main front laths 9a, 9b (not shown) and the additional front lath 11 are not flush with the front surface 12 of the core panel 1 but are protruding. An external finishing material 26 such as a wood cladding can be attached to the main front laths 9e, 9f, to the main front laths 9a, 9b (not shown) and to the additional front lath 11 whereby a second space 28 in addition to space 22 is provided.

In Fig. 6 a type of cross-section of the main back laths 7e, 7f and of the additional back lath 18 is illustrated which allows the attachment of a fire protection material 30, such as a gypsum layer, directly to the back surface 2 of the core panel 1.

Fig. 7 illustrates a cross-section through an embodiment of the composite building element similar to that illustrated by Fig. 5. However, the front surface 12 of the core panel 1 is not provided with grooves or rabbets.

The following example illustrates the composite building element of the present invention and its shear resistance compared to known building elements used in the industry.

Example

A type of composite building element illustrated in Figs. 1 to 3 is tested. The core panel consists of rigid extruded polystyrene foam of a density of about 45 kg/m³. The length of the panel is 240 cm, the width 120 cm and the thickness 80 mm. The stiff back frame is built of four main spruce laths of 75 mm x 55 mm cross-section and an additional spruce lath of 40 mm x 55 mm cross-section. In the corners, the main timber frame built by the spruce laths of 75 mm x 55 mm cross-section is reinforced by diagonally divided square steel nail plates of 300 mm side length and a thickness of 2 mm. The steel plates are nailed irregularly and glued with a polyurethane adhesive to the back frame and to the core panel. The stiff front frame is built of four main spruce laths and an additional spruce lath of 50 mm x 30 mm cross-section. The back and front timber frames are glued with a polyurethane adhesive to the back and front surfaces of the core panel.

Comparative Example A

- 20 A spruce frame of 240 cm length and the same width is produced of
- 5 parallel laths of 240 cm length placed at equal distance from each other, the middle lath has a cross-section of 45 x 97 mm and the other four laths have a cross-section of 36 x 97 mm, and
 - a pair of studs of 36 x 97 mm cross-section which are perpendicular to the set of 5 parallel laths. Each stud is fixed to each lath with two nails of 3.3 x 90 mm.

The shear resistance of this frame is provided by a sheet of 8 mm plywood nailed with nails (2.1 x 45 mm) on each lath and stud of the frame, every 15 cm on the studs and the two outside laths and every 30 cm on the three middle laths. A gypsum plaster board is nailed to the other side of the frame. The space between these two faces is filled with a glass fiber insulation of 100 mm thickness.

Comparative Example B

The same frame as described in Comparative Example A is produced. The shear resistance is provided on both sides by a sheet of 12 mm chipboard nailed with nails (2.8 x 55 mm) every 15 cm on the studs and the two outside laths and every 30 cm on the three middle laths of the frame. The space between the two chipboard sheets is filled with a glass fiber insulation of 100 mm thickness.

For testing the shear resistance of the building elements, two identical composite building panels of the Example are installed vertically side by side, fixed firmly to the floor and interconnected. One panel of each of Comparative Examples A and B is also installed vertically and fixed firmly to the floor. Across the surface of the panels variable horizontal shearing forces are applied near the upper edge of the panels. The following table illustrates

the weight of the building elements,
the horizontal shearing force (load) which needs to be
applied until the building element breaks,
the horizontal shearing force (load) which is necessary to
5 cause 5 mm deflection of the building element in the cases
where a) no vertical load and b) additionally 2.5 kN
vertical load is applied and
the insulation properties of the building elements.

	<u>Example 1</u>	<u>Comp. Example A</u>	<u>Comp. Example B</u>
Overall dimension (mm)	2400 x 2400	2400 x 2400	2400 x 2400
Weight (kg)	62	71	137
Horizontal load at rupture (kN)	39,6	11	28
Horizontal load for 5 mm deflection with 2.5 kN vertical load (kN)	5,05	3,92	7
Horizontal load for 5 mm deflection with no vertical load (kN)	4	2,51	5
Thermal conductivity (W/m ² K)	0,28	0,34	0,32

11

1	Core panel
2	Back surface (of the core panel)
3	Stiff back frame
5	Stiff front frame
7a, b, c, d, e, f	Main back laths
8, 18	Additional back lath
9a, b, c, d, e, f	Main front laths
10, 11	Additional front lath
12	Front surface (of the core panel)
14a, b	Rabbets
16	Groove
20	Interior finishing layer
22	Space
24	External rendering
26	External finishing material
28	Second space
30	Fire protection material

PATENT CLAIMS

1. A composite building element comprising
 - a) a core panel (1) of a rigid foamed material of an expanded synthetic resin and
 - b) two stiff frames (3, 5) of essentially the same length and the same width as the length and width of the core panel (1), bonded to the back and front surfaces (2, 12) of the core panel (1).

2. The composite building element of claim 1 wherein each frame (3, 5) consists of a first set of at least two laths (7a, 7b, 9a, 9b) and a second set of laths (7c, 7d, 7e, 7f, 8, 9c, 9d, 9e, 9f, 10, 11) whereby the laths of the second set are parallel to each other and are perpendicular to at least one lath of the first set.

3. The composite building element of claim 1 wherein each frame (3, 5) consists of a first set of at least two parallel laths (7a, 7b, 9a, 9b) and a second set of at least two parallel laths (7c, 7d, 7e, 7f, 8, 9c, 9d, 9e, 9f, 10, 11) which second set of laths is perpendicular to the first set of laths and the laths have a cross-section of from 20 mm x 20 mm to 150 mm x 150 mm.

4. The composite building element of claim 2 or 3 wherein the laths of the frames are made of wood, metal or concrete.
5. The composite building element of any of claims 1 to 4 wherein the core panel (1) is a rigid extruded polystyrene foam panel having a density of from 20 to 60 kg/m³.
6. The composite building element of claim 5 wherein the core panel (1) is a rigid extruded polystyrene foam panel having a density of from 30 to 50 kg/m³.
7. The composite building element of any of claims 1 to 6 wherein the front and/or the back surface (12, 2) of the core panel (1) is provided with a rabbet (14a, 14b) along the edges of the core panel (1) and/or with one or more grooves (16).

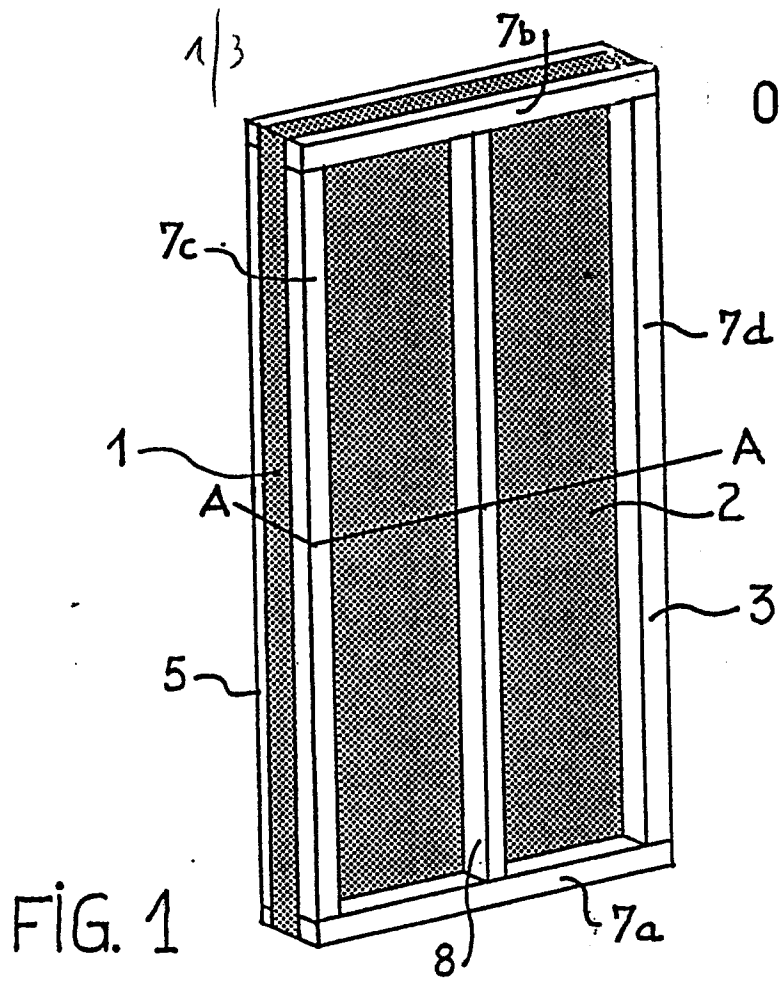

FIG. 1

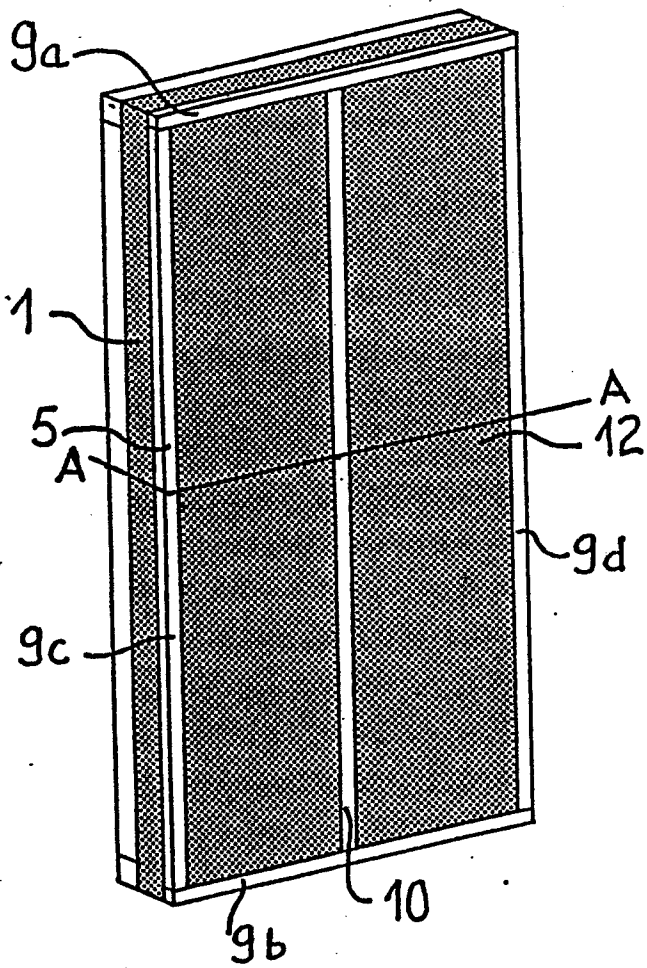

FIG. 2

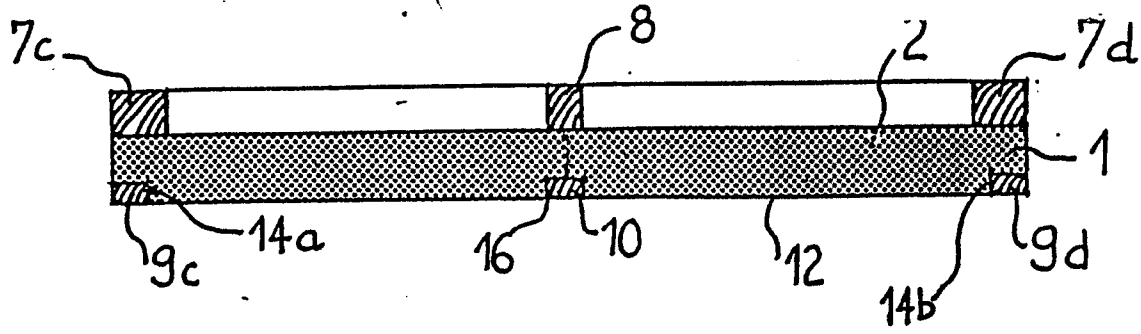

FIG. 3

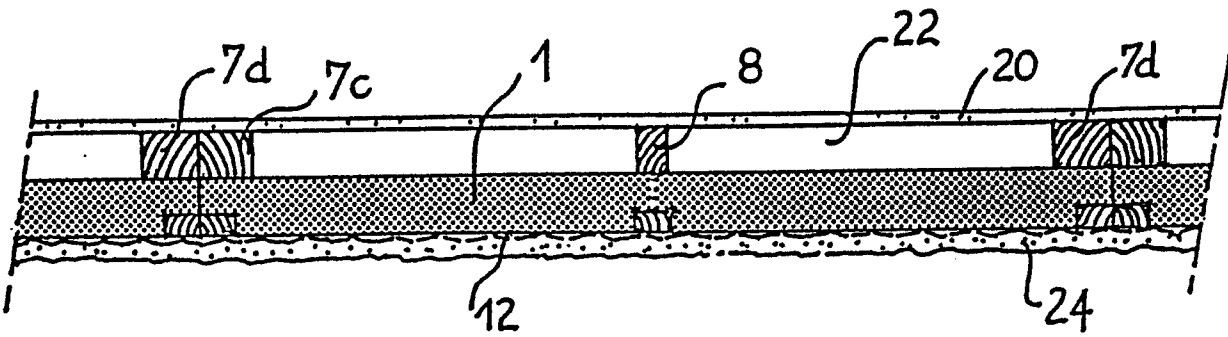

FIG. 4

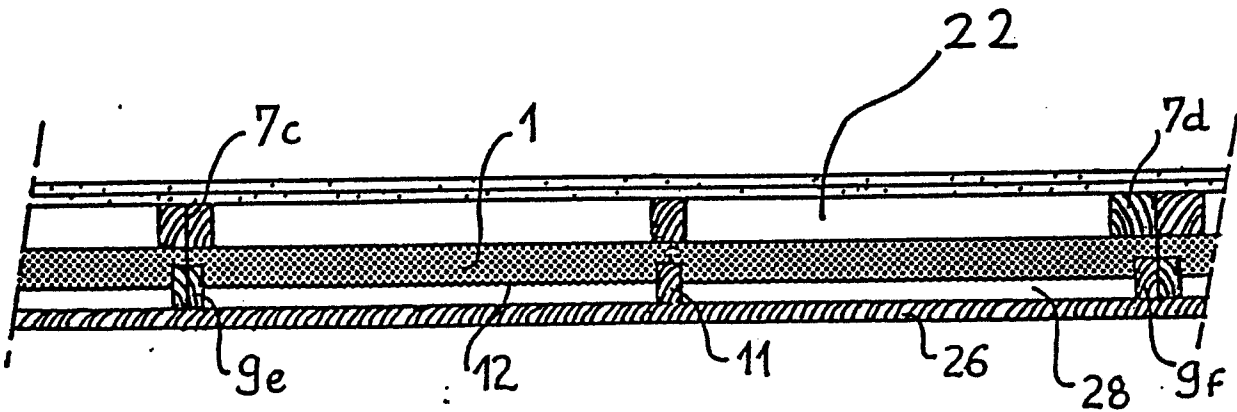

FIG. 5

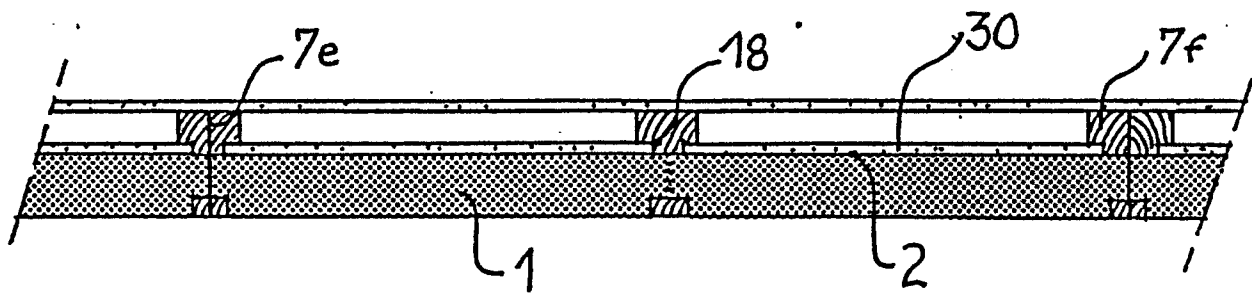

FIG. 6

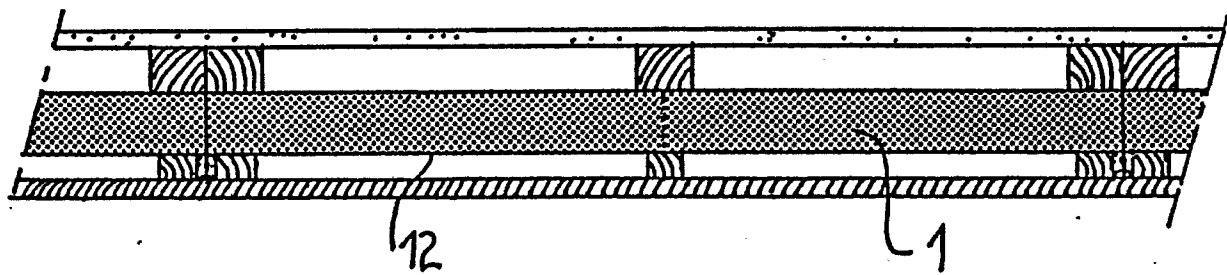

FIG. 7



European Patent
Office

EUROPEAN SEARCH REPORT

0260435

Application Number

EP 87 11 1611

DOCUMENTS CONSIDERED TO BE RELEVANT			
Category	Citation of document with indication, where appropriate, of relevant passages	Relevant to claim	CLASSIFICATION OF THE APPLICATION (Int. Cl.4)
X	DE-A-2 816 935 (SAMUELSSON) * Page 9, last paragraph; page 10, last paragraph; figures 2,3,6-9 *	1	E 04 C 2/38
A	-----	2-4,7	
			TECHNICAL FIELDS SEARCHED (Int. Cl.4)
			E 04 C
The present search report has been drawn up for all claims			
Place of search THE HAGUE		Date of completion of the search 23-11-1987	Examiner VANDEVONDELE J. P. H.
<p>CATEGORY OF CITED DOCUMENTS</p> <p>X : particularly relevant if taken alone Y : particularly relevant if combined with another document of the same category A : technological background O : non-written disclosure P : intermediate document</p> <p>T : theory or principle underlying the invention E : earlier patent document, but published on, or after the filing date D : document cited in the application L : document cited for other reasons</p> <p>..... & : member of the same patent family, corresponding document</p>			

EPO FORM 1503 03.82 (P0401)