

624742

FORM 1
REGULATION 9

COMMONWEALTH OF AUSTRALIA

PATENTS ACT 1952-1973

APPLICATION FOR A PATENT

We HUGHES AIRCRAFT COMPANY

of 7200 Hughes Terrace, Los Angeles, CALIFORNIA 90045-0066, U.S.A.

hereby apply for the grant of a Patent for an invention entitled:

SATELLITE BEAM-FORMING NETWORK SYSTEM HAVING IMPROVED BEAM SHAPING

which is described in the accompanying complete specification. This Application is a Convention Application and is based on the Application numbered: 434,059 for a Patent or similar protection made in U.S.A. on 8 November 1989.

Our address for service is:

GRIFFITH HACK & CO
71 YORK STREET
SYDNEY NSW 2000

DATED this 17th day of October 1990

HUGHES AIRCRAFT COMPANY
By their Patent Attorney

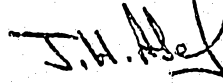

GRIFFITH HACK & CO

TO: THE COMMISSIONER OF PATENTS
COMMONWEALTH OF AUSTRALIA

5017869 17/10/90

6810A:rk

PATENTS ACT 1952 (AS AMENDED)

DECLARATION IN SUPPORT OF AN APPLICATION FOR A PATENT

Name of applicant) In support of an Application made by: HUGHES AIRCRAFT COMPANY

Title) for a patent for an invention entitled: SATELLITE BEAMFORMING NETWORK SYSTEM HAVING IMPROVED BEAM SHAPING

Full name of I, signatory) Wanda K. Denson-Low
Address of signatory) of 7200 Hughes Terrace
Los Angeles, California 90045-0066
United States of America

do solemnly and sincerely declare as follows:

1. I am authorised by the above mentioned applicant for the patent to make this Declaration on its behalf.

Insert details of inventor(s)

2. The name and address of each actual inventor of the invention is as follows:

Timothy A. Murphy - 17733 Spruce Way, Lynnwood, Washington, 98037, United States of America

Kenneth H. Renshaw - 1817 Agnes Road, Manhattan Beach, California 90266, United States of America

Insert details of assignment, etc.)

and the fact(s) upon which the applicant is entitled to make this application are as follows:

An assignment by the inventors to the applicant dated October 28, 1989 (Timothy A. Murphy) and November 7, 1989 (Kenneth H. Renshaw).

Delete paragraphs 3 and 4 for Non-Convention application)

3. The basic application(s) as defined by Section 141 of the Act was(were) made as follows:

Country United States of America on November 8, 1989
in the name(s) Timothy A. Murphy and Kenneth H. Renshaw
and in on
in the name(s)
and in on
in the name(s)

4. The basic application(s) referred to in the preceding paragraph of this Declaration was(were) the first application(s) made in a Convention country in respect of the invention the subject of this application.

Place and date of signing)

Declared at LA, CA this 29th day of August 1990

Signed: [Signature]
Position: Wanda K. Denson-Low
Assistant Secretary

(12) PATENT ABRIDGMENT (11) Document No. AU-B-64765/90
(19) AUSTRALIAN PATENT OFFICE (10) Acceptance No. 624742

(54) Title
SATELLITE BEAM-FORMING NETWORK SYSTEM HAVING IMPROVED BEAM SHAPING

International Patent Classification(s)
(51)^s **H01Q 021/22 H01Q 003/40**

(21) Application No. : **64765/90** (22) Application Date : **17.10.90**

(30) Priority Data

(31) Number (32) Date (33) Country
434059 08.11.89 US UNITED STATES OF AMERICA

(43) Publication Date : **16.05.91**

(44) Publication Date of Accepted Application : **18.06.92**

(71) Applicant(s)
HUGHES AIRCRAFT COMPANY

(72) Inventor(s)
TIMOTHY A. MURPHY; KENNETH H. RENSHAW

(74) Attorney or Agent
GRIFFITH HACK & CO. , GPO Box 4164, SYDNEY NSW 2001

(56) Prior Art Documents
AU 604082 10410/88 H01Q 3/22 3/40 25/00 H04B 7/185

(57) Claim

1. An antenna system comprising:

a reflector having a focal point associated therewith;

an antenna array having a plurality of radiating elements and responsive to signals provided thereto for producing beams of electromagnetic radiation covering a target area, at least certain of said antenna beams including undesirable side lobes;

at least one additional radiating element positioned along with said array, said array and said additional radiating element being operatively disposed near the focal point of said reflector, said additional radiating element being responsive to said signals to produce a first additional beam of electromagnetic radiation having a center portion falling outside of said target area and a fringe portion overlapping at least a first portion of said target area, said fringe portion of said first additional beam combining with said certain of said antenna beams to reduce said side lobes; and

means operatively connected with said antenna array and said one additional radiating element for performing an approximate spatial transformation on the amplitude and phase distribution of said signals provided to said antenna array and said one additional radiating element.

(11) AU-B-64765/90
(10) 624742

-2-

14. A method of operating a steerable beam antenna system of the type including a reflector having a focal point and a plurality of radiating elements responsive to signals provided thereto, said plurality of radiating elements being disposed generally at said focal point of said reflector and forming scanning beams of electromagnetic energy directed by said reflector at a target area to scan across and collectively cover said target area, said target area having at least one side wherein the scanning beams which are directed to said one side include undesirably high side lobes of electromagnetic energy, comprising the steps of:

(a) providing a set of first signals having a predetermined phase relationship with respect to each other and containing information to be transmitted;

(b) generating a set of second signals from said set of first signals by at least approximately performing a spatial transformation on the amplitude and distribution of said set of first signals;

(c) creating said scanning beam by transmitting preselected ones of said second set of signals towards said reflector by passing said preselected ones of said second set of signals through said plurality of radiating elements; and

(d) creating at least one additional beam by transmitting at least one signal in said second set of signals towards said reflector by passing said at least one signal through an additional radiating element located along with said plurality of radiating elements, said additional beam being directed so that the center portion thereof falls outside of the target area, and the fringe portion of the additional beam falls upon said one side of said target area, said fringe portion of said additional beam combining with said scanning beam to reduce said side lobes to a desirable level.

624742

COMMONWEALTH OF AUSTRALIA

PATENTS ACT 1952

Form 10

COMPLETE SPECIFICATION

FOR OFFICE USE

Short Title:

Int. Cl:

Application Number:
Lodged:

Complete Specification-Lodged:
Accepted:
Lapsed:
Published:

Priority:

Related Art:

TO BE COMPLETED BY APPLICANT

Name of Applicant: HUGHES AIRCRAFT COMPANY

Address of Applicant: 7200 Hughes Terrace, Los Angeles,
CALIFORNIA 90045-0066, U.S.A.

Actual Inventor: Timothy A. Murphy and Kenneth H. Renshaw

Address for Service: GRIFFITH HACK & CO
71 YORK STREET
SYDNEY NSW 2000

Complete Specification for the invention entitled:

SATELLITE BEAM-FORMING NETWORK SYSTEM HAVING
IMPROVED BEAM SHAPING

The following statement is a full description of this
invention, including the best method of performing it
known to us:-

3782-ML:CLC:RK

6810A:rk

SATELLITE BEAM-FORMING NETWORK SYSTEM
HAVING IMPROVED BEAM SHAPING

5

BACKGROUND OF THE INVENTION

1. Field of the Invention

This invention relates to an antenna for satellites to communicate with ground stations and, more particularly, to an antenna system for satellites incorporating an antenna array for producing a communicating beam which has improved side lobe characteristics around the fringes of the ground area covered by the antenna.

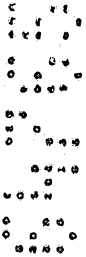

10

2. Description of the Related Art

Satellites are now employed for providing communication, such as land mobile telephone service, between distant points on the surface of the earth. One embodiment of such a system of considerable interest is that in which the satellite travels in a geostationary orbit about the earth. The satellite may be located at a fixed position above the United States and carries an antenna having a sufficient beam width in the north-south direction and in the east-west direction to permit the reception and transmission of communication signals between any two points in the United States. The beam width in the north-south direction can be enlarged to include both United States and Canada, if desired. A beam width of approximately 4.5° in the north-south direction is sufficient to cover both Canada and the United States. The beam width in the east-west



15



20



25



direction should be approximately 8° to provide the desired coverage. A problem arises in that the use of an antenna having the foregoing beam width in the north-south and east-west directions has less signal gain than is desired. This necessitates larger power amplifiers for driving radiating elements of the antenna.

In previous satellite communication systems, such a wide beam width antenna has employed at least two overlapping beams to provide the coverage. The generation of such beams with a desired overlap until very recently required the use of separate large reflectors each having a diameter of about 16 feet. In the construction of communication satellites, however, it is desirable to reduce physical sizes, weights, and power requirements to facilitate the construction and launching of such satellites.

In US 782770

which is hereby incorporated by reference, there is disclosed a system for communicating via satellite between ground stations. The system comprises a set of ground stations spaced apart along an arc of the earth's surface and a satellite positioned above the earth in view of the arc. An array of radiating elements is deployed on the satellite, and a frequency responsive beam former connected to the radiating elements is provided for forming a beam of electromagnetic radiation. The beam is steerable in response to a carrier frequency of the radiation to intercept individual ones of the stations in seriatim. The frequencies of an uplink carrier and of a downlink carrier respectively associated with respective ones of the ground stations vary monotonically with position along the arc to permit automatic positioning of a beam from the satellite to a ground station upon energization of a carrier frequency assigned to the ground station.



So that the present invention may be better understood, the satellite communication system disclosed and claimed in the aforementioned application will now be discussed in some detail by reference to Figs. 1 through 5. As shown in Figs. 1 and 2, the satellite 24 employs a simplified antenna structure 30 comprised of two confocal parabolic reflectors, one of which is a large main reflector 32 and one of which is a small subreflector 34, and a 4 x 2 array 40 of eight radiating elements 42, all of which are supported by a frame 44. A front view of the array 40 is shown in Fig. 2. The array 40 of radiators 42 is rigidly secured in front of the subreflector 34, and the subreflector is located within the satellite 24. The main reflector 32 is substantially larger than the subreflector 34 and due to the larger size is folded during launch and subsequently unfurled when the satellite or spacecraft 24 has been placed in orbit. Upon being unfurled, it extends outside of the satellite 24 as shown. Also shown in Fig. 1 within the frame 44 is other spacecraft equipment such as rocket engines and fuel tanks, thereby to demonstrate that the antenna system 30 can be easily carried by the satellite 24.

The arrangement of the components of the antenna system 30 provides a significant reduction in weight and complexity for a satellite antenna over that which has been employed before. This is accomplished by fabricating the main reflector 32 and the subreflector 34 with parabolic reflecting surfaces, the two surfaces being oriented as a set of confocal parabolas having a common focal plane or point 48. Such configuration of reflecting surfaces in an antenna is described in C. Dragone and M. Gans, "Imaging Reflector Arrangements to Form a Scanning Beam Using a Small Array," Bell System Technical Journal, Vol. 58, No. 2 (Feb. 1979), pp. 501-515. The configuration provides a magnification of the effective aperture of an array of radiating elements. In the preferred configurations as shown in Figs. 1 and 2, the magnification

factor is 4.7. The eight radiating elements 42 of the array 40 represent a substantial reduction in complexity of the antenna since, if a direct radiator of similar sized elements had been employed, a total of 155 radiating elements would have been needed to give the same antenna performance. As shown in Fig. 3, a hexagonally arranged antenna array 50 of seven primary radiators 52 may be used if desired in place of the 4 x 2 array of radiators mentioned above. The array 50 of feed elements 52 may be employed for both uplink and downlink communications.

Fig. 4 illustrates two exemplary spot beams 56, 58 produced by the satellite 24 (not shown in Fig. 4) in geosynchronous orbit above the earth 60. Spot beam 56 extends substantially along the eastern coast of the United States 62 and Canada 64, while spot beam 58 extends substantially along the western coast of the United States 62 and Canada 64. The satellite transmits and receives information-carrying radiation to and from ground stations located within regions of the earth's surface encompassed by the respective first and second spot beams 56, 58. The coverage patterns of the respective spot beams 56, 58 preferably are selected such that frequency bands available for communications are concentrated in regions of the surface of the earth 60 where the largest communications capacity is necessary to optimize antenna gain usage by substantially limiting the amount of antenna gain which is incident upon regions wherein relatively little communications capacity is necessary, such as in sparsely populated regions.

The antenna system of satellite 24 provide a one-dimensional, beam scan (which may be considered to be a continuum of virtual spot beams) across the surface of the earth 60. Such a scan can be directed along an arc of the earth's surface, such as a longitude or a latitude, or an arc included relative to a latitude. The scanning can be accomplished most efficiently for the geography depicted in Fig. 4 by scanning in the east-west direction, providing a scan path which follows an

arc of a great circle of the earth. The scanning is preferably implemented by using fixed delays (as will be described hereinafter) among radiating elements of the antenna system and by employing different frequencies for different geographical locations on the surface of the earth. Thereby, the scanning is accomplished by variation of the frequency of the radiation for each position of the beam scan (i.e., for each virtual beam), and in addition, a plurality of the beams (not shown) can be generated simultaneously by the provision of different frequencies of electromagnetic radiation in each of the beams. By use of this virtual beam technique, users at any point within the coverage of the beam scan are close to the center of one of the virtual beams. Therefore, users will typically receive 2 or 3 dB more power than they would from a comparable satellite using fixed beams.

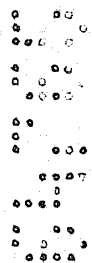

To minimize the required electromagnetic power and provide for simplicity of antenna structure, the preferred antenna system provides beams with a generally circular cross-section and a width of 4.5° by use of the hexagonal array of radiating elements as shown in Fig. 3. The elements preferably are cup dipole feed horns one wavelength in diameter.

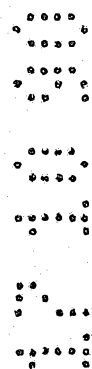

As an example of its use, the satellite communications system may be designated for land mobile telephone service, sometimes referred to as the Mobile Satellite (MSAT) system. Two frequency bands are assigned for such service: 866-870 MHz for the downlink band and 821-825 MHz for the uplink band. The 4 MHz width of each of these bands may be subdivided into approximately 1000 frequency slots which are individually assignable to individual ground stations on the surface of the earth for compounded single sideband voice communication. Other frequency bands may be utilized, for example, such as the L-band. If the stations were uniformly positioned from east to west, with each station being at a different longitude, approximately twelve assignable channels

comprising an uplink and a downlink would be available within a scan angle of approximately 0.1 degree.

5 Since the channels would be uniformly spaced apart in frequency, a beam would be uniformly stepped in the east-west direction as the downlink (or uplink) frequency was shifted from one channel to the next channel. In other words, the operating frequency of the ground station is preferably selected to match the frequency of a beam directed from the satellite to the ground station. For a uniform distribution of the stations in the east-west direction, the beam could be centered with respect to the east-west component thereof upon each of the stations. However, as a practical matter, the stations tend to be clustered in various geographic areas of the United States 62 and Canada 64 providing a nonuniform distribution of the stations along the east-west scanning path of the beam. Consequently, a peak signal amplitude cannot be obtained for all of the stations.

10
15
20
25
30
By way of example, assuming that 25 ground stations are located within a scan angle of 0.1°, the corresponding reduction from peak signal amplitude is less than 0.01 dB (decibels). This represents a significant improvement over previously available satellite communication systems employing separate fixed beams wherein the average loss in signal gain relative to peak signal gain in the east-west direction was approximately 0.8 dB. As noted above, such previous satellite communication systems employed antenna systems having a plurality of large antenna reflectors, measuring approximately 16 feet in diameter, while the antenna system described in the aforementioned patent application requires only one such large reflector and a much smaller confocal subreflector as will be described hereinafter. Thus, the disclosed system provides for improved uniformity of signal gain with a simplified mechanical structure of the antenna system.

Fig. 5 presents a diagram useful in explaining the frequency scanning operation of the antenna system. A set of four radiating elements 42 are arranged side by side along a straight line and face an outgoing wavefront 66 of electromagnetic radiation. The angle of incidence of the wavefront or beam scan angle is measured relative to a normal 68 to the array 40 of elements 42. A frequency scan is generated in a planar array antenna by introduction of a progressive time delay into the array. The progressive time delay provides for a difference in the phases of signals excited by adjacent ones of the elements 42 such that the phase difference is proportional to the frequency of the radiated signals. This explanation of the operation assumes an outgoing wavefront, it being understood that the operation of the array of elements 42 is reciprocal so that the explanation applies equally well to an incoming wavefront. It should be noted here that the desired frequency dependent port-to-port phase progression may be achieved by using techniques other than time delays, such as through the use of an all-pass network. The relationship of scan angle to frequency, element spacing and time delay is given by the following equations:

$$2\pi D \sin \theta = \Delta\psi = 2\pi f \Delta T \quad (1)$$

therefore,

$$\sin \theta = \frac{\lambda}{D} f \Delta T \quad (2)$$

wherein:

D = spacing between elements,

θ = beam scan angle,

λ = wavelength of radiation,

$\Delta\psi$ = phase increment between adjacent elements,

f = frequency relative to band center, and

ΔT = time delay increment between adjacent elements.

The radiating elements 42 are energized via a source 70 of microwave energy and a series of delay units 72 coupled to the source 70. Each of the delay units 72 provides the time delay increment referred to above in Equations (1) and (2). The source 70 is connected directly to an element 42 at the left side of the array while the next element 42 is connected by one of the delay units 72 to the source 70. The signals applied by the source 70 to the third and the fourth of the elements 42 are delayed, respectively, by two and three delay increments of the delay units 72. This provides the linear phase relationship to provide the scan angle for the outgoing wavefront 66. The phase increment between two adjacent ones of the radiators 42 is proportional to the product of the frequency of the radiation and the delay increment. When this product is equal to 360° , the wavefront propagates in a direction normal to the array of element 42. Increasing values of frequency produce greater phase shift to direct the wavefront to the right of the normal 68 as shown in Fig. 5, while decreasing amounts of frequency produce less phase shift and drive the wavefront to the left of the normal. Accordingly, the wavefront can be scanned symmetrically about the array of elements 42.

U.S. Patent Application serial number 782770 also discloses that for the case of the foregoing uplink and downlink frequency bands, and for the case of the radiating elements 42 having a diameter of approximately one wavelength, a suitable value of differential delay, as provided by the delay units 72 of Fig. 5, is 185 nanoseconds for the case of substantially uniform distribution of ground stations on the surface of the earth 60. To provide the east-west coverage of 8° , the uplink and the downlink beams are scanned through an arc from -4° to $+4^\circ$. In view of the magnification factor of 4.7, the scan angle of the array 40 of radiating elements 42 must be enlarged by the same magnifying factor, 4.7, from that of the output scan from the main reflector 32. Therefore, the beam produced by the radiating elements 42 must be scanned through an arc of 18.8° to



either side of a normal to the array 40. The foregoing value of differential delay, namely 185 nanoseconds, provides the 18.8° scan to either side of the normal to the array 40. In the ideal situation of uniformly distributed ground stations between the east coast and the west coast of the United States and Canada, the number of channels per degree has a constant value of $1000/8 = 125$.

In the situation wherein the differential delay provided by the delay units 72 are independent of frequency, then an optimal direction of the scanned beam is obtained for the ideal situation of uniform distribution of ground stations. In the more likely situation of a nonuniform distribution of ground stations, the scanned beam may be displaced slightly from its designated ground station. As has been noted above, such a beam-pointing inaccuracy reduces the signal level by less than 0.01 decibels for a beam-pointing error of 0.1 degree.

The aforementioned patent application discloses that the scanning can be adapted to accommodate the foregoing nonuniformity in ground station distribution by introducing a frequency-responsive component to the differential delay. It gives an example of nonuniform distribution where the differential delay between columns of the array 40 of radiating elements 42 (see Fig. 4) should vary, at least for the forming of the downlink beams, between 262 nanoseconds at the low frequency end of the transmission band to 131 nanoseconds in the high frequency end of the transmission band. Other values of delay may be employed in the beam-forming operation of uplink beams provided by the receiver of the antenna system (30).

The values of delay used in the different frequency bands, namely the uplink and downlink frequency bands, are inversely proportional to the center frequencies of these bands as is apparent from Equations (1) and (2). A reduction in the differential delay results in a reduced amount of phase shift

between successive beams with a corresponding reduction in displacement of beam position on the surface of the earth 60 from one channel to the next channel. Thereby, the beam can be more accurately positioned in a region of high density of ground stations. In a corresponding fashion, an increase in the differential delay results in increased movement of the beam as the frequency is shifted from one channel to the next channel, thus accommodating positions of the beam to a less dense distribution of ground stations. The channel number corresponds to a specific frequency in either the uplink or the downlink band. With respect to the positioning of ground stations along an arc of a great circle of the earth 60, as disclosed with reference to Fig. 4, it is seen that the frequencies selected for the various stations vary monotonically with position along the foregoing arc.

5
10
15
20

In view of the foregoing description, it is seen that the above-described communication system provides two-way communications between ground stations and a geosynchronous satellite. The assignment of specific frequencies to respective ones of the ground stations, in combination with frequency scanning of both uplink and downlink beams of the satellite (24), permits a simplification in the circuitry of the system. In addition, the use of the two confocal parabolic reflectors provides a multiplicative factor which reduces the number of elements required in the array of radiating elements. The use of a scanned beam also reduces the physical size of the antenna system by reducing the number of reflectors, resulting in a lighter weight, more efficient satellite communications system.

25
30

It has been found that certain technical impediments exist to the commercial implementation of the above-described confocal reflector system. One such impediment is the system's lack of efficiency. Due to spacecraft size limitations, the subreflector 34 cannot be constructed large enough (in terms of wavelengths) to perform with acceptable efficiency. These size

limitations also restrict the size of the main reflector and the focal lengths that may be used in the confocal arrangement.

5 Another impediment is the beam distortion which is present when the beam scans toward the edge of the coverage area. This beam distortion is undesirable because it reduces the overall capacity of the system to transmit information.

10 It would be desirable, in order to achieve a further weight-saving and simplification of the aforementioned satellite communications system, to eliminate the subreflector altogether while still utilizing a relatively low number of radiating elements. It would also be very advantageous to be able to combine the power of output signals from several individual amplifiers operated in parallel into an individual one or small group of the radiating elements so as to produce a stronger spot beam in any given location along the area of the earth being swept by the scanning beam. It would further be desirable to use as many elements as possible as common element in an antenna system for the transmitter antenna system and receiver antenna system of a communications satellite so as to save weight, space and cost. Still, another desirable feature would be to reduce beam distortion which presently occurs when the beam which is transmitted from the antenna is swept towards the edge of the coverage area. The present invention is directed to achieving these and other desirable objects.

25 SUMMARY OF THE INVENTION

30 In light of the foregoing objects, there is provided in one embodiment of the present invention an antenna system including a reflector having at least one focal point associated therewith and an antenna array having a plurality of feed elements for transmitting beams of electromagnetic radiation onto a target area. The antenna system comprises: means operatively connected to the antenna array for performing an

approximate spatial transformation on the amplitude and phase distribution of input signals provided thereto; at least one additional feed element positioned along with the array of feed elements, the additional feed element being used to produce a beam which has a center portion that falls outside of the target area and a fringe portion which overlaps a portion of the target area, and wherein the antenna array, the additional feed element, and the reflector are positionable relative to each other such that the antenna array and the additional feed element are operatively disposed near the focal point of the reflector when the reflector is in its intended operating position. The spatial transformation which is performed is selected from the group of transformations consisting of discrete Fourier transforms and inverse discrete Fourier transforms. The transformation performing means includes a Butler matrix having a plurality of input ports and a plurality of output ports. The antenna array, including the one additional feed element and the Butler matrix, is preferably used for both transmission and reception of signals. When the antenna system is used for reception, the input signals provided to the spatial transformation means are signals obtained from electromagnetic radiation focused by the reflector onto the antenna array for reception by the feed elements, and the spatial transformation is an inverse discrete Fourier transform. When the system is used for transmission, the spatial transformation means produces signals provided to the antenna array and the additional feed element, and the spatial transformation is a discrete Fourier transform. When used as a transmitter, the system preferably further comprises means for feeding the input ports of the Butler matrix with a set of signals having a predetermined phase relation from input port to input port.

The antenna system of the present invention is preferably used in a satellite for communication with ground stations. In such an application, the system typically is

further comprised of a satellite frame to which the reflector and antenna array are attached. The reflector and antenna array are operatively arranged with respect to one another to enable a steerable beam produced by electromagnetic radiation emanating from said array to be reflected off the reflector when the reflector is in its intended operating position.

5

Another aspect of the present invention is a method of operating a steerable beam antenna system comprising the steps of: (a) providing a set of first signals having a predetermined phase relationship with respect to one another and containing information to be transmitted; (b) generating a set of signals from said set of first signals by at least performing an approximate spatial transformation on the amplitude and distribution of said set of first signals by at least performing an approximate spatial transformation on the amplitude and distribution of said set of first signals; (c) creating a scanning beam by transmitting preselected ones of said second set of signals towards the reflector by passing said preselected ones of said second set of signals through a plurality of radiating elements; and (d) creating at least one additional beam by transmitting at least one signal in the second set of signals towards the reflector by passing said at least one signal through an additional radiating element located along with the plurality of radiating elements, the additional beam being directed so that the center portion of the beam falls outside of the target area, and the fringe portion of the beam falls upon said target side area, said fringe portion of said additional beam combining with said scanning beam to reduce said side lobes to a desirable level. The method further comprises providing a Butler matrix in order to generate said set of second signals from said set of first signals and wherein said spatial transformation is a discrete Fourier transform.

10

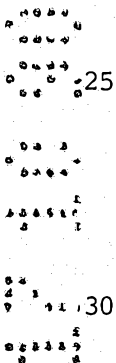
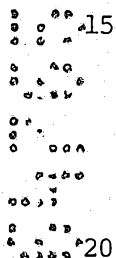

The method is preferably used in satellite communications systems for communicating with multiple ground

stations through the use of the steerable beam associated with the antenna system. In such applications, the reflector is a main reflector and is mounted on the satellite.

5 These and other aspects, objects, features and advantages of the present invention will be more fully understood from the following detailed description and appended claims, taken in conjunction with the drawings.

BRIEF DESCRIPTION OF THE DRAWINGS

In the accompanying drawings:

10 Fig. 1 is a side elevational view of a communications satellite, showing an array of radiators, an imaging reflector and primary reflector;

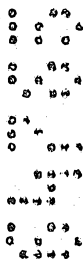
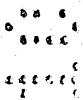

Fig. 2 is a front view of the rectangular array of radiators in the Fig. 1 satellite;

15 Fig. 3 is a front elevational view of the antenna subsystems shown in Fig. 1, which employs an alternative hexagonal arrangement of radiators;



Fig. 4 is a stylized pictorial view of spot beams formed on the surface of the earth using the Fig. 1 satellite;



20 Fig. 5 is a diagram showing a relationship between an outgoing wavefront and the elements of a line array of radiators;



25 Fig. 6 is a simplified diagrammatic representation of an antenna system of the present invention usable in a satellite;

Fig. 7 is an optical diagram showing a dual lens system;

5 Fig. 8 is a simplified electrical diagram of a four-port Butler matrix usable in an antenna system of the present invention;

Fig. 9 is a plot, as a function of input phase, of the amplitude of the output signal of port A of the Fig. 8 Butler matrix when ports A', B', C' and D' are fed with a specified set of input signals;

10 Fig. 10 is a plot, as a function of input phase, of typical amplitudes of all of the output ports in the Fig. 8 Butler matrix when the matrix is fed with a specified set of input signals;



15 Fig. 11 is a simplified electrical block diagram showing a set of duplexers and a Butler matrix used in common by transmitter and receiver networks in an antenna system of the present invention;



20 Fig. 12 is an electrical diagram of one embodiment of a receive network of the present invention which introduces port-to-port phase differences into a received set of signals through the use of progressive time delays or frequency-dependent phase shifts;

25 Fig. 13 is an electrical block diagram of one embodiment of a transmit network of the present invention having functional similarities to the receive network shown in Fig. 12;

Fig. 14 is an electrical block diagram of a dual-frequency, dual-signal transmit network of the present invention for simultaneously summing and preparing for transmission a plurality of distinct frequency signals;

Fig. 15 is a block diagram of a four-port Butler matrix;

Figs. 16A-E are graphs of amplitude distributions into and out of a four-port Butler matrix; and,

5 Fig. 17 is a combined block and pictorial view of spot beams formed on the surface of the earth by a satellite antenna array in accordance with the present invention.

DETAILED DESCRIPTION OF THE PREFERRED EMBODIMENTS

10 The present invention comprises a novel antenna system for communicating with multiple ground stations typically distributed over a large geographical area of the earth. The following description is presented in conjunction with the technical description set forth above to enable any person skilled in the art to make and use the invention and is provided in the context of a particular application and its requirements. Various modifications to the preferred
15 embodiments will be readily apparent to those skilled in the art, and the generic principle defined herein may be applied to other embodiments and applications without departing from the spirit and scope of the invention. Thus, the present invention is not intended to be limited to the embodiments shown, but is to be accorded the widest scope consistent with the principles and features disclosed herein.

20 As shown in Fig. 6, the antenna system 80 of the present invention includes a main reflector 32 and an array 40 (or 50) of radiators 42 (or 52) of the type described in Figs. 1 through 5 above. The antenna system 80 is preferably located on satellite 24 by being mounted on a suitable frame 44. In the
25 antenna system 80 of the present invention, the subreflector 34 (shown in Figs. 1 and 3) is removed and the array 40 (or 50) of
30

primary radiators 42 (or 52) or feed horns is placed at (or near) the focal point or plane 48 of the offset feed reflector 32. The array 40 (or 50) is fed by a Butler matrix 82 which is arranged "backwards" with respect to the traditional use of this type of beam-forming matrix. Connected to the matrix 82 are the transmitter and receiver networks represented by block 84. The use of a Butler matrix in this manner produces an excitation sequence for the antenna system 80 which is the spatial discrete Fourier transform of the excitation sequence input to the beam-forming array of primary radiators in the antenna system 30 of Figs. 1 through 5. In this way, the far field pattern produced by the array and signal reflector is identical (in the ideal case) to that of the previously described confocal arrangement. There will be some difference in the non-ideal case due to the effects of spatial sampling and the physical limitations on the size of the array that may be placed at the focal point.

The operation of the antenna system 80 shown in Fig. 6 and the foregoing explanation of same may be better understood by considering the equivalent optical model of the conformal reflector configurations, shown in Figs. 1 and 3 previously described above. Fig. 7 shows the equivalent optical model 90 of this earlier antenna system 30 employing two lenses 92 and 94 which correspond in function to the main reflector 32 and the subreflector 34 respectively. The focal plane x represented by line 96 includes the focal point 48. The focal length of lens 92 is F_2 , while the focal length of lens 94 is F_1 . The magnification factor M of the system 90 in Fig. 7 is given by:

$$M = F_2/F_1 \quad (3)$$

An amplitude and phase distribution of an image, $F(x)$, at the image plane x represented by line 98, is magnified by lenses 92

and 94 such that at the magnified image plane x'' represented by line 100:

$$f(x'') = F(M X) \quad (4)$$

5 From optical theory, it is well known that the amplitude and phase distribution at the focal plane x' is the spatial discrete Fourier transform of the amplitude and phase distribution at the image plane X . That is to say:

$$f(x') = F[f(x)] \quad (5)$$

10 By removing the first lens and producing $f(x')$ directly at the focal plane x' , the same amplitude and phase distribution will result at the magnified image plane x'' . The antenna system 80 of the present invention is based upon this idea.

Returning to Fig. 6, it may be seen that the Butler matrix 82 in the system 80 performs the spatial discrete Fourier transform of the excitation sequence generated by the transmitter in block 84. It may also be seen that the Butler matrix 82 performs the spatial inverse discrete Fourier transform, $F^{-1}[f(x'')]$, of the far field beam reflected off reflector 32 and focused onto the antenna array 40 (or 50) for reception by the feed elements 42 (or 52) and subsequent processing by the receiver in block 84.

Fig. 8 illustrates a four-port Butler matrix 110 which has a set of four inputs and a set of four outputs. The Butler matrix 110 includes four 90° phase lead hybrids 112 and two negative 45° phase shifters 114 interconnected to one another and to the two sets of four ports as shown. The four-port matrix 110 is considered here for simplicity, but as those in the art know, Butler matrices can be designed with any number of desired ports. In this regard, much work has been done in developing design technique for Butler matrices, see,

e.g., M. Ueno, "A Systematic Design Formulation for Butler Matrix Applied FFT Algorithm," IEEE Trans. Antennas and Propagation, Vol. AP-29, No. 3, May 1981. In the traditional use of this matrix, ports A, B, C and D would be the input ports, and ports A', B', C' and D' would be the output ports and would be attached to radiator elements in an antenna system which does not use a reflector. When the antenna system 80 of the present invention is used to transmit, ports A', B', C' and D' are used as the input ports, and ports A, B, C and D are used as the output ports. In the system 80 used as a transmitter, the ports A', B', C' and D' are fed with a set of signals that have some predetermined phase relationship from port to port that is a function of frequency. If the same signals were fed to a planar antenna array, different spot beams, each with a different beam direction, would be formed for the different frequencies. We sometimes refer to these spot beams as virtual beams, since in theory a continuum of beams exists over the entire beam width defined by the lowest frequency to highest frequency spot beams. The different phase distributions resulting from different frequencies are combined in the matrix 110 and constructively or destructively combine on different output ports. The effect is the creation of a virtual phase center in the array of signals at output ports A, B, C and D for each frequency. In other words, the phase center of an antenna array 40 (or 50) having a plurality of radiator elements 42 (or 52) with one such element attached to ports A, B, C and D will scan as a function of frequency. A particular frequency may result in a signal at one and only one port, or it may result in signals at two or more ports whose amplitude and phase correspond to a spatial phase center somewhere between the ports.

Curve 120 of Fig. 9 shows the amplitude response of port A in Fig. 8 when input ports A', B', C' and D' of matrix 110 are fed with a set of input signals defined by:

$$X_n(t) = \sin(\omega t + n\psi) \quad n = 0, 1, 2, 3 \quad (6)$$

where Ψ is varied from 0 to 2 pi. (In the usual frequency scan technique, the input phase value Ψ is some function of frequency and is not necessarily constant.) Port A' corresponds to $n = 0$, port B' to $n = 1$ and so forth. Note that at a particular phase distribution a maximum signal level occurs at port A. Figure 10 shows the magnitudes of the output signals on all ports when the matrix 110 is fed with the same type of signal sequence described above. Curves 122, 124 and 126 are the output signals on all ports when the matrix 110 is fed with the same type of signal sequence described above. Curves 122, 124 and 126 are the output signals of ports B, C and D, respectively. Note that each port has a maximum output value for a different relative input phase value Ψ . Note also that of a maximum amplitude for a particular port, the outputs of the other ports are zero. For example, when curve 120 associated with port A is of its maximum at point 128, curves 122-126 are at zero amplitude at point 130. Further analysis shows that the phase center of the antenna array attached to the output of the Butler matrix (as illustrated in Fig. 11) will scan the length of the array 40 (or 50) as a function of Ψ . Different frequencies result in different phase centers of the antenna array.

The performance of an antenna system employing a Butler matrix is affected by the number of elements used. The more elements used the better the spatial sampling of the input and output signal sequences. Thus, it will be appreciated that a Butler matrix with relatively few ports performs a rough approximation of a discrete Fourier transform (or inverse discrete Fourier transform) on signals passing therethrough. As the number of ports increases, the quality and accuracy of the transformation performed increases.

Fig. 11 illustrates in greater detail how the Butler matrix 110 may be used in an antenna system 138 of the present invention which includes transmitter and receiver subsystems.

The system 138 includes an array 140 of feed elements or horns 142 which are used both as radiating elements and receiving elements. The horns 142 may be of any conventional or suitable design, such as a cup dipole one wavelength in diameter. In practice, the horns 142 function in the same basic manner as the radiating elements 42 (or 52) described earlier and are located at or very near the focal plane or plane of an offset feed reflector 32 as in the Fig. 6 arrangement.

The system 138 also includes a group 144 of diplexers 146, a receive network 148 and a transmit network 150 which are respectively connected to the diplexers 146 by groups 152 and 154 of electromagnetic conduits or conductors. These components may all be of conventional or suitable design. For the diplexers 164, however, we prefer to use diplexers of the type fully described in commonly assigned U.S. Patent No. 4,427,953 to T. Hudspeth and H. Keeling entitled "MICROWAVE DIPLEXER." The diplexers 146 serve to properly route incoming signals in the uplink frequency band (received by the antenna array 140, transformed by the matrix 110, and impressed upon conductors of conductor group 156) to the receive network 148. Similarly, the diplexers 146 serve to route the set of signals in the downlink frequency band (generated by the transmit network 150 and impressed upon conductor group 154) to the Butler matrix 110 where they are transformed and impressed on conductor group 158 for delivery to the antenna array 140. Note that in Fig. 11 the output of ports B and C of the Butler matrix 110 is reversed in order to obtain a continuous scan of the virtual phase center with frequency. This is accomplished by having port B connected by conduit 158b to feed horn 142c and having port C connected via conduit 58c to feed horn 142b as shown. The need to reverse the outputs of the beam ports B and C is clear when one observes that in Fig. 10 the curves 122 and 124 representing for the output signals of ports B and C are reversed with respect to the ordering of the output signals of ports A and D, from high to low values of input phase Ψ . The

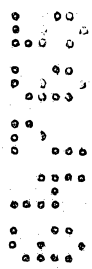

15

20

25

30

two 180° phase shifters 159a and 159b correct for phase reversals in the output signals of ports A and B, which occur on account of the operation of the Butler matrix 110.

5 Fig. 12 is a block diagram for one possible embodiment which shows the various components and signal paths of the receive network 148 of antenna system 138 in Fig. 11. The network 148 includes: a group 160 of preamplifiers 162 for boosting the level of the received signals delivered by conduits 152; a group 164 of frequency translators 166 for reducing the carrier frequency of received signals from preamplifiers 162 to
10 an intermediate or baseband frequency range; a group 168 of four bandpass filters 170 for rejecting side lobes or other frequency translation products outside of the desired frequency range; and a group 172 of three shift-producing components or elements 172, all connected together as shown to produce a baseband signal on output terminal or port 176. The shift producing elements 174 may either be time delay elements or frequency-dependent phase shifters. The receiver network 148 is tuned to the frequency bands of the respective uplink communication channels, thereby
15 permitting simultaneous reception of signals from a plurality of ground stations.

20 Fig. 13 is a block diagram of the transmit network 150 shown in Fig. 11. The network 150 includes: a group 180 of shift-producing components or elements 182; a group 184 of four frequency shifters 186 for increasing the carrier frequency of signals imposed on group of conduits 188 to a higher frequency range, a group 190 of bandpass filters 192 for removing unwanted signals outside of the desired frequency range generated by the operation frequency translators 186; and a group 194 of power amplifiers 196 to boost the power of the signals impressed on conductor group 154. In the transmit network 150, the signal to be transmitted is imposed upon input terminal or port 198.
25
30

5 Figs. 12 and 13 also illustrate one possible method
for producing the port-to-port input phase value Ψ as a function
of frequency through the introduction of time delays or
frequency-dependent phase shifts. These are introduced through
the shift-producing elements 174 in Fig. 12 and the
10 shift-producing elements 182 in Fig. 13. In Fig. 13, the time
delays or phase shifts are introduced at baseband (or some
intermediate frequency), and then each signal in the resultant
signal set is imposed on a conduit of conduit group 188 in order
to be frequency-translated in parallel by frequency translators
186 up to the desired frequency range. This is done so that a
particular bandwidth will produce the desired range of phase
distributions in the signal set applied to the Butler matrix 110
15 through conductor group 154 and therefore result in the scanning
of the phase center of the array across to the desired range.
This method can be advantageously applied, for example, in the
MAST system discussed in the background portion of the
specification.

20 The MSAT system satellite discussed above will
transmit in the UHF band at 866 to 870 MHz (or in the L-band if
desired). The change in phase of a sinusoid due to a time delay
such as those in Figs. 12 and 13 can be calculated by the
following formula where input phase value is expressed in
radians:

$$\Delta\Psi = n2\pi\tau \quad (7)$$

25 In order to produce a sufficiently large beam scan angle when
using the Butler matrix 110 shown in Fig. 8, a fairly wide range
of phase distributions is required.

30 One approach for determining what time delays or
phase shifts are required to operate the system 138 of Fig. 11
in the desired manner is to choose the optimum range of phase
distributions and find a frequency at which the bandwidth in

question will produce this range using a time delay or phase shifting device. For example, the Butler matrix 110 shown in Fig. 8 will provide the best scanning of the phase center of the antenna array if the input phase distributions range between $\pi/4$ and $7\pi/4$ radians. For simplicity, assume a time delay will be used. Hence, setting the conditions:

$$\pi/4 = 2\pi f_1 \tau \quad (8)$$

and

$$7\pi/4 = 2\pi f_2 \tau \quad (9)$$

then

$$\tau = 7\pi/8\pi f_2 = \pi/8\pi f_1 \quad (10)$$

or

$$f_2/f_1 = 7 \quad (11)$$

Combining this relationship with the idea that

$$f_2 - f_1 = 4 \text{ MHz} \quad (12)$$

i.e., in the bandwidth of downlink transmissions in the MAST satellite, we can find that $f_1 = 666.7 \times 10^3$ Hz and $f_2 = 4.6667 \times 10^6$ Hz. Working at this intermediate frequency range, we can now find a time delay that will produce the desired range of phase distributions, namely $\tau = 1/(8f_1) = 187.5 \times 10^{-9}$ seconds. Working with this time delay at this intermediate frequency band allows the bandwidth of the signal to produce the desired port-to-port frequency-dependent phase relationships. Each signal in the set can then be frequency-translated up to the desired frequency range (in parallel) without changing the

port-to-port phase relationship introduced by the time delays at the intermediate frequency band.

By using different time delays and different intermediate frequencies, the signals from different transmitters (or to different receivers) may be combined to use the same Butler matrix and produce the same type of antenna patterns, even if the transmitters are operating at different frequencies and have different bandwidths. Using the technique described above, different signals with different bandwidths may be used to produce sets of input signals with the same range of phase distributions. Applying the combination of these sets to the Butler matrix feeding an antenna array allows both signal bandwidths to produce the same frequency scanned virtual beam patterns. This concept is illustrated in Fig. 14 which shows a dual-frequency transmit network 210 capable of generating two sets of output signals at different frequency bands. The network 210 may be used in place of transmit network 150 in the antenna system 138 shown in Fig. 11.

The network 210 includes a first frequency network portion 212, a second frequency network portion 214, and a common network portion 216. Network portion 212 is comprised of a group 180 of three shift-producing devices 182 and a group 184 of frequency translators 186 which operate as previously explained in Fig. 13. Network portion 214 includes a group 222 of shift-producing devices 224 and a group 226 of frequency translating devices 228 for producing a set of signals at a different frequency band from those produced by network portion 212. The shift-producing devices 182 and 224 may be time delay units or frequency-dependent phase shift units. Network portion 216 includes: a group 230 of sum-producing elements or mixers 232 (which combine the two different sets of signals from network portions 212 and 214 delivered to the mixers 232 via conductor groups 234 and 236, respectively); a group 190 of band pass filters 192; and a group 194 of power amplifiers 196. The

various components of network 210 are connected as shown in Fig. 14 and result in the production of two sets of signals having different frequency bands which are combined, amplified and then simultaneously impressed upon conductor group 154 for delivery to the remainder of the system 138 shown in Fig. 11.

The shift-producing units or devices 174, 182 and 224 may be conveniently fabricated of lumped parameter all-pass networks employing well-known circuitry. These units or devices are located ahead of the transmitting power amplifiers 184 and 196 in Figs. 13 and 14 so as to operate at relatively low power and thereby minimize power loss.

To summarize at this point, the steerable beam antenna system described above provides a significant reduction in satellite weight by eliminating one of the two confocal parabolic reflectors which are used to provide two-way communications between ground stations and a geosynchronous satellite. Also provided is a technique for combining the power of output signals from several individual amplifiers operated in parallel into an individual one or small group of feed elements so as to more efficiently produce a stronger spot beam in a given location within the target area. In addition, the system described above provides for a technique wherein several antenna elements are used for both receiving and transmitting electromagnetic radiation. By providing two functions with several common elements, weight, space and cost of the satellite are reduced.

Although the antenna system described above is highly effective, it produces beams which, at the outer edges of the target area, have undesirably high side lobes. The present invention, however, provides a solution to this problem, and in this connection reference is now made to Fig. 15, wherein a Butler matrix 110 is shown having four inputs a', b', c', and d' and four outputs a, b, c, and d. The Butler matrix 110 is



comprised of four 90° phase lead hybrids 112 and two negative 45° phase shifters 114 interconnected as shown. The outputs of the Butler matrix a-d are routed to feed elements 116-119. The feed elements 116-119 deliver the electromagnetic radiation to a confocal reflector (not shown) which reflects and redirects the radiation to the target area. Outputs a and d are routed through 180° phase shifters 115 before they deliver the outputs of their respective Butler matrix ports to their respective feed elements. As previously disclosed, the Butler matrix 110 is used to perform a spatial discrete Fourier transform on the incoming signals a'-d' to produce a focal plane field distribution equivalent to the common focal plane distribution in a dual confocal reflector system. If the Butler matrix feed arrangement as shown in Fig. 15 is used, some undesirably high side lobes will be present in the scanning beam whenever it scans towards the edge of the target area as mentioned above. The presence of these undesirable side lobes can be explained by referring to Fig. 16.

5

10

15

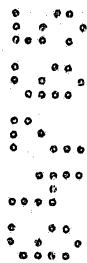

20

Shown in Fig. 16a is a hypothetical amplitude distribution which may be applied to Butler matrix 110 via its input ports a'-d'. This hypothetical amplitude distribution will be used as a reference in discussing the output distributions shown in Figs. 16b-16e. As can be seen in Fig. 16a, the input distribution maintains a constant amplitude from port-to-port and a constant port-to-port phase gradient. Fig. 16b shows the output that would be present on feed elements 116-119 if the input to the Butler matrix 110 was fed by four constant amplitude signals which shared a constant phase gradient of -45°. Note that for this hypothetical input phase gradient, all of the power radiated from horns 116-119 would be output from port 2. Assuming that a phase gradient of 45° was presented to the signals that were input to the Butler matrix 110, Fig. 16c shows that all of the power output from the Butler matrix 110 would be output from port 3, and no power would emanate from ports 1, 2 or 4. Fig. 16d shows that if the four

25

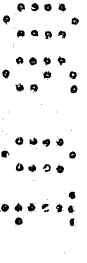

30



35

inputs to the Butler matrix a'-d' share a 0° phase gradient (i.e. they are all in phase), each output port then contributes to the total output power. Note that Fig. 16d shows there is a 180° phase reversal on the outside ports. Also shown in Fig. 16d is the electrical phase center 300 of the array for the input phase gradient of 0° . Fig. 16e shows the output of the Butler matrix for an input phase gradient of 90° . Note that like Fig. 16d, each of the ports contributes some power to the overall output of the array, and that there is a 180° phase reversal on left-side port 2. Shown at 302 in Fig. 16e is the approximate location of the electrical phase center of the array for an input phase gradient of 90° .

The case in Fig. 16e illustrates the presence of undesirable side lobes for an input phase gradient of 90° . In this case, unlike the cases in Figs. 16b-16d, the excitation of the horns 116-119 is asymmetric about the electrical phase center of the array. This asymmetry in the feed excitations causes an asymmetry in the beam patterns for these intermediate beam positions which occur near the edge of the array. In other words, as the electrical phase sensor of the array scans towards the edge of the array, the beam shape degrades or dilates. This dilation is undesirable because in order to accommodate it, the system bandwidth and consequently system capacity must be sacrificed. A novel approach has been developed and is herein disclosed for eliminating this beam dilation. This novel approach will now be described in conjunction with Fig. 17.

Now referring to Fig. 17, a standard eight-port Butler matrix 110 is shown having eight input ports 310 and eight output ports 312. Eight-port Butler matrices of this nature are well-known to those in the art of satellite communications. Four of the outputs of the eight-port Butler matrix 116-119 are shown terminated at output feeds 1-4. This correlates to the arrangement used in Fig. 15. Two of the remaining outputs from the Butler matrix are terminated into

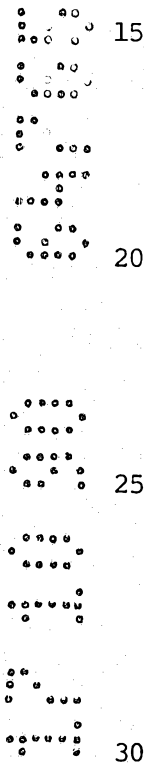

output feeds which flank output feeds 116-119 and are shown as output feeds 314 and 316. The remaining two outputs of the Butler matrix are terminated into the non-radiating load elements 318, 320.

5 The novel technique disclosed herein for eliminating the undesirable dilation of the arrayed beam involves using additional feed elements in the following unique manner. As can be seen from Fig. 17, primary feed elements 116-119 adequately cover the target area (continental United States) 322. Antenna
10 feeds 314 and 316 are used to flank the primary feeds and to create beam patterns that do not concentrate their energy on the target area. This is illustrated in Fig. 17 by noting that the beam pattern projected by feed element 314 does not in fact fall upon the continental United States. Likewise, the beam pattern
15 emanating from feed element 316 is shown off of the east coast of the continental United States and predominantly falling within the Atlantic Ocean. Note that the reflector has been omitted from Fig. 17 for the sake of clarity and explanation, but would in fact be employed in a normal working system.

20 The primary beams 324-330 fall upon the target area generally along a common axis. These beams emanate from the feed elements 116-119 and are used to transmit information throughout the target area. The outer feeds 314 and 316 are used only for beam shaping and consequently are not used for
25 information transmission. In Fig. 17, beam patterns 332 and 334 are drawn to show what the beam pattern would look like if a sufficiently high amount of energy was delivered to feed element 314 and 316. However, in the disclosed system, beam 332 and 334 are never used as primary beams, but rather they are used as
30 secondary beams and consequently they are excited with only a fraction of the energy which is normally delivered to the primary beams. Feeds 314 and 316 are used to produce secondary beams for the purpose of beam shaping as the phase center of the antenna array moves between intermediate beam positions. Beam

shaping is accomplished by virtue of the secondary beam destructively interacting with the undesirable side lobes which accompany the primary beams when the primary beams scan towards the outer ends of the antenna array. The inclusion of these
5 feeds 314, 316 provides for a more symmetric array excitation, and hence a better pattern shape results at the intermediate beam positions. It is important to note that in addition to destructively combining with the undesirable side lobes of its adjacent neighbors, a secondary beam also acts to reduce the
10 side lobes which are produced by its more remote neighboring beams of the array, although the further away from a given secondary beam the side lobe occurs, the less the secondary beam's effect on that side lobe.

Although two of the outputs of the Butler matrix 110
15 are shown in a terminated state 318, 320, they along with feed elements 314 and 316 can be used to perform beam shaping. If all eight outputs of the Butler matrix 110 were used, the system's overall ability to eliminate beam dilation would be even greater than it is when only six of the outputs of the
20 Butler matrix 110 are used. Terminating the two outputs as shown in Fig. 17 introduces a small power loss. For the case illustrated in Fig. 17, if the input phases are restricted such that beams 322 and 330 represent the maximum beam scan position, the maximum power loss is -0.33 dB. If one watt of power is presented to feed element 116, then $.0732$ watt would be dissipated in the loads shown at 318 and 320. If all eight
25 ports of the Butler matrix 110 are used for beam shaping, this loss will not occur.

The foregoing embodiments of the present invention
30 have been described with respect to a mobile satellite communications system for transmitting and receiving between multiple ground stations at certain specified frequencies in the L band. Those skilled in the art will appreciate that the present invention may be readily adapted for use in land or

satellite communication systems operated in other frequency bands, such as the C or Ku bands, for example. The number of additional radiating elements, which are added to eliminate side lobes, is not limited to one or two. Any number of additional radiating elements may be added, each of which will act to further reduce undesirable side lobes. The size of the main reflector, the arrangement and type of antenna arrays, and the specific receive and transmit networks utilized in the present invention may vary substantially without departing from the scope of the broader aspects of the present invention. For example, separate feed horns may be used to transmit and receive electromagnetic radiation constituting the steerable beam. Also, a conventional screen-type diplexer may be placed between the antenna array and reflector so as to divert the incoming electromagnetic radiation to be received to a separate receiver array arranged at a substantial angle to the plane of the first antenna array. Such an embodiment would thus have separate transmit and receive antenna arrays. Alternatively, two separate main reflectors could be provided, one to be used with a separate transmit antenna array and the other to be used with a separate receive antenna array. We presently do not favor this latter arrangement for satellite antenna systems of the present invention on account of the appreciable extra weight and cost of providing two main reflectors. However, such an embodiment may be quite suitable for systems of the present invention constructed on land or on sea-going vessels.

In view of the foregoing description, it is seen that the antenna system of the present invention is well-suited for two-way communications between ground stations and a geosynchronous satellite. The antenna system of the present invention has the advantages of effectively combining the power of the output signals of a plurality of power amplifiers simultaneously operated in parallel. It also provides a single reflector antenna system which, through the use of a spatial transformation means such as a Butler matrix, is functionally

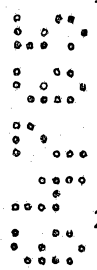

equivalent to the dual confocal reflector system described in the background portion of the specification, including achieving a magnification of the effective aperture of the elements. The antenna system of the present invention eliminates the need for the use of a subreflector without providing additional radiating elements, thus saving weight, space and cost. Since the antenna system of the present invention uses a scannable virtual beam technique, it also reduces the physical size of the antenna system by minimizing the number of radiating elements and reflectors which must be used. The present system also acts to reduce the undesirable side lobes that occur as the radiated beam scans towards the edge portions of the target area. This side lobe suppression is achieved by placing additional radiating elements along with the main array and using the additional radiating elements to produce beams of energy which cancel the undesirable side lobes which accompany the primary beams. Thus, an antenna system of the present invention results in a lighter weight, more efficient satellite communication system. Finally, the use of time delays or phase shifts at baseband or intermediate frequencies allows the output of multiple transmit networks to be applied to a single array of radiating elements to produce the same antenna pattern at different frequencies, thus enabling the antenna system to be used in satellite communication systems requiring a multiple, two-way, simultaneous communication channel between many widely separated ground stations within the scanning angle of the virtual beams.

It is to be understood that the above-described embodiments of the present invention are illustrative only and that modifications thereof may occur to those skilled in the art. Accordingly, the present invention is not to be regarded as limited to the embodiments or methods disclosed herein but is to be limited only as defined by the appended claims.

THE CLAIMS DEFINING THE INVENTION ARE AS FOLLOWS:

1 1. An antenna system comprising:
 a reflector having a focal point associated
 therewith;

 an antenna array having a plurality of radiating
 elements and responsive to signals provided thereto for
5 producing beams of electromagnetic radiation covering a target
 area, at least certain of said antenna beams including
 undesirable side lobes;

 at least one additional radiating element positioned
 along with said array, said array and said additional radiating
10 element being operatively disposed near the focal point of said
 reflector, said additional radiating element being responsive to
 said signals to produce a first additional beam of
 electromagnetic radiation having a center portion falling
 outside of said target area and a fringe portion overlapping at
15 least a first portion of said target area, said fringe portion
 of said first additional beam combining with said certain of
 said antenna beams to reduce said side lobes; and

20
25
30
35
40
45
50
55
60
65

 means operatively connected with said antenna array
 and said one additional radiating element for performing an
 approximate spatial transformation on the amplitude and phase
 distribution of said signals provided to said antenna array and
 said one additional radiating element.

2. A system as in claim 1, wherein each of said
radiating elements is a feed horn arranged in a hexagonal
pattern.

1 3. A system as in claim 1, wherein said approximate
 spatial transformation means is a Butler matrix having a
 plurality of input ports and an equal number of output ports.



1 4. A system as in claim 3, wherein said output ports of
said Butler matrix are connected to said at least one additional
radiating element and said radiating elements of said antenna
array and wherein said spatial transformation is a discrete
5 Fourier transform.

1 5. A system as in claim 4, further including means for
feeding said input ports of said Butler matrix with a set of
signals having a predetermined phase relationship defined by the
formula:

5 $X_n = \sin(\omega t + n\psi) \quad n = 0, 1, 2, 3$

where n identifies the relative position of each signal within
said set of signals, ψ is an input phase value in the range from
0 to 2π , and ω is the frequency of the signal.

1 6. A system as in claim 5, wherein the input phase
value ψ varies as a function of frequency ω .

1 7. A system as in claim 3, further including:
first means for generating, from a first signal
having a first nominal frequency, a first set of second signals
shifted in phase from one another for delivery to said
5 transformation means in order to enable said system to produce a
frequency scanning virtual beam containing information encoded
in said first signal.

1 8. A system as in claim 7, wherein said first means for
generating includes a plurality of phase shift-producing
elements, each capable of effectively phase-shifting a signal
passed therethrough and each being associated with one of said
5 second signals.

1 9. A system as in claim 8, wherein each phase
shift-producing element is a time delay device.

1 10. A system as in claim 3, wherein certain of said output ports are respectively connected to said radiating elements and said one additional radiating element and at least one other of said outputs is connected to a nonradiating load.

1 11. A system as in claim 1, wherein said beams and said one additional beam are substantially aligned along a common reference axis at the respective points of impingement of said beams on said target area.

1 12. A system as in claim 1, including a second radiating element positioned along with said array and spaced apart from said one additional radiating element, said second radiating element being operatively disposed near the focal point of said reflector and responsive to said signals to produce a second additional beam of electromagnetic radiation having a center portion falling outside of said target area and a fringe portion overlapping at least a second portion of said target area spaced from said first portion of said target area, said fringe portion of said second additional beam combining with said certain of said antenna beams to reduce said side lobes.

5
10

1

13. A system as in claim 1, wherein said beams and said first and second additional beams are substantially aligned along a common reference axis at the respective points of impingement of the beams on said target area.

1 14. A method of operating a steerable beam antenna
system of the type including a reflector having a focal point
and a plurality of radiating elements responsive to signals
provided thereto, said plurality of radiating elements being
5 disposed generally at said focal point of said reflector and
forming scanning beams of electromagnetic energy directed by
said reflector at a target area to scan across and collectively
cover said target area, said target area having at least one
side wherein the scanning beams which are directed to said one
10 side include undesirably high side lobes of electromagnetic
energy, comprising the steps of:

(a) providing a set of first signals having a
predetermined phase relationship with respect to each
other and containing information to be transmitted;

15 (b) generating a set of second signals from said
set of first signals by at least approximately performing
a spatial transformation on the amplitude and distribution
of said set of first signals;

(c) creating said scanning beam by transmitting
20 preselected ones of said second set of signals towards
said reflector by passing said preselected ones of said
second set of signals through said plurality of radiating
elements; and

(d) creating at least one additional beam by
25 transmitting at least one signal in said second set of
signals towards said reflector by passing said at least
one signal through an additional radiating element located
along with said plurality of radiating elements, said
additional beam being directed so that the center portion
thereof falls outside of the target area, and the fringe
30 portion of the additional beam falls upon said one side of
said target area, said fringe portion of said additional
beam combining with said scanning beam to reduce said side
lobes to a desirable level.

1 15. A method as in claim 14, wherein step (b) is performed by using a Butler matrix to generate said second set of signals from said set of first signals, and wherein said spatial transformation is a discrete Fourier transformation.

1 16. A method as in claim 14, wherein the predetermined phase relationship of said set of first signals is at least substantially defined by:

$$x_n(t) = \sin(\omega t + n\Psi) \quad n = 0, 1, 2, 3$$

5 where n identifies the relative position of each first signal within the set of first signals, and Ψ is the input phase value in the range from 0 to 2 pi, and ω is the frequency of the signal.

1 17. A method as in claim 14, wherein step (a) includes the substeps of:

- (1) providing a baseband signal; and
- (2) introducing a plurality of time delays into said baseband signal to generate at least a plurality of said first signals.

1 18. A method as in claim 14, wherein steps (c) and (d) are performed such that said scanning beam and additional beams impinge said target area along substantially a common axis.

1 19. A method as in claim 14, including the step of creating a second additional beam directed so that the center portion thereof falls outside the target area, and the fringe portion of said second additional beam combining with said scanning beam to reduce said side lobes to said desirable level.

1 20. A method as in claim 19, wherein the first and second additional beams are directed so that said fringe areas thereof are spaced apart from each other.

21. A method of operating a steerable beam antenna system substantially as hereinbefore described with reference to the any one embodiment shown in the accompanying drawings.

Dated this 17th day of October 1990

HUGHES AIRCRAFT COMPANY
By their Patent Attorney
GRIFFITH HACK & CO.

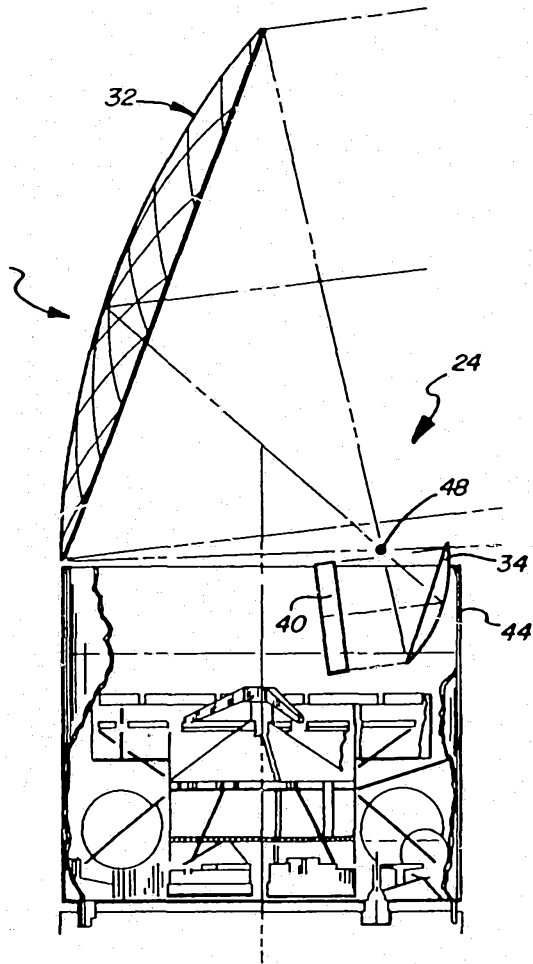
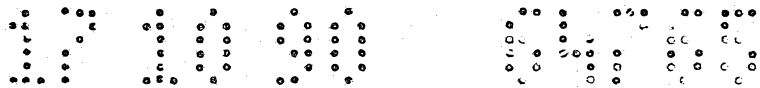

FIG. 1

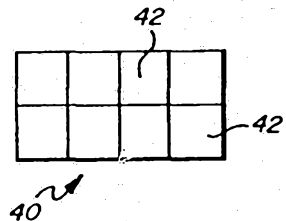

FIG. 2

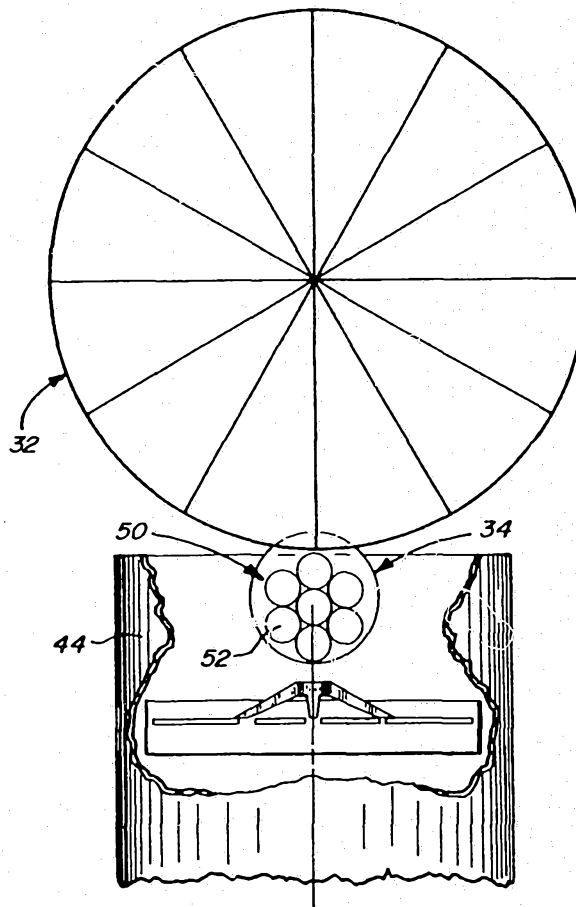

FIG. 3

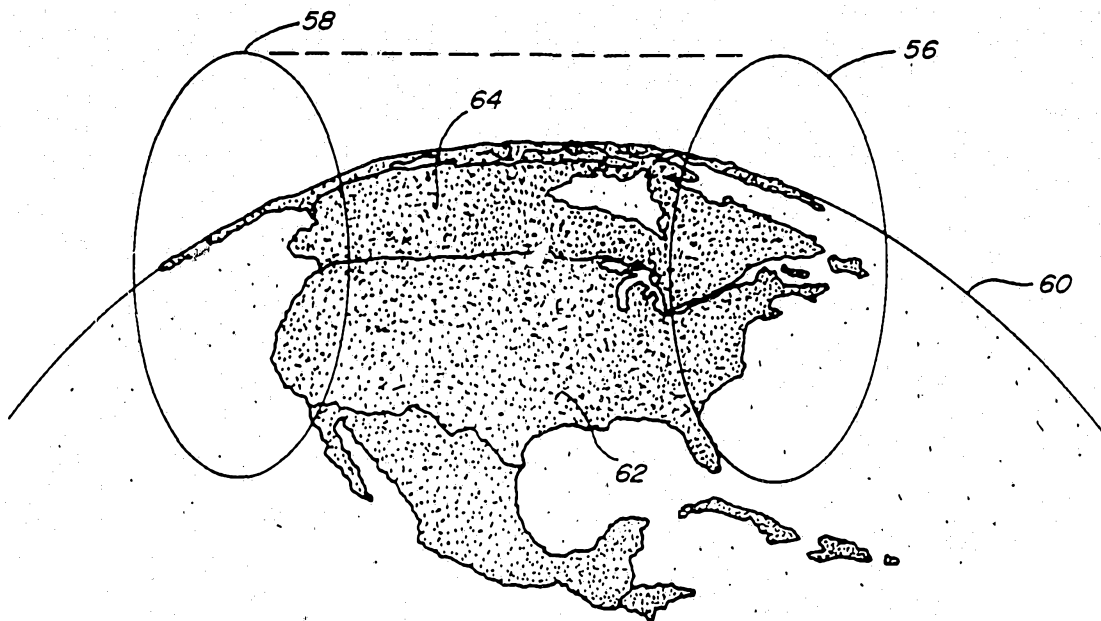

FIG. 4

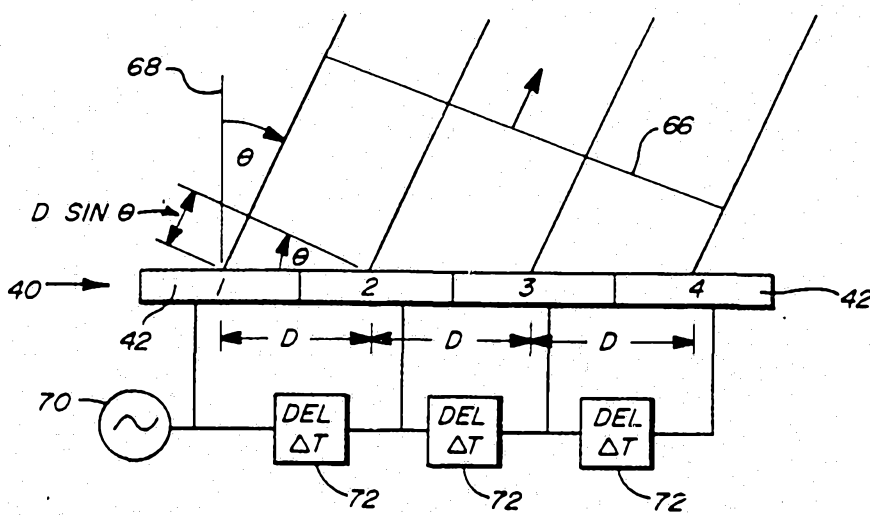

FIG. 5

FIG. 6

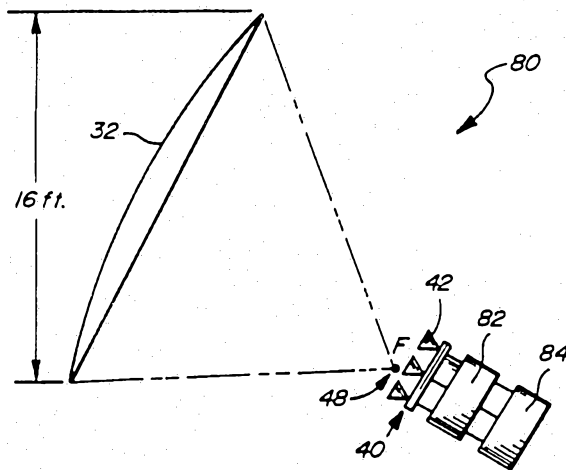

FIG. 7

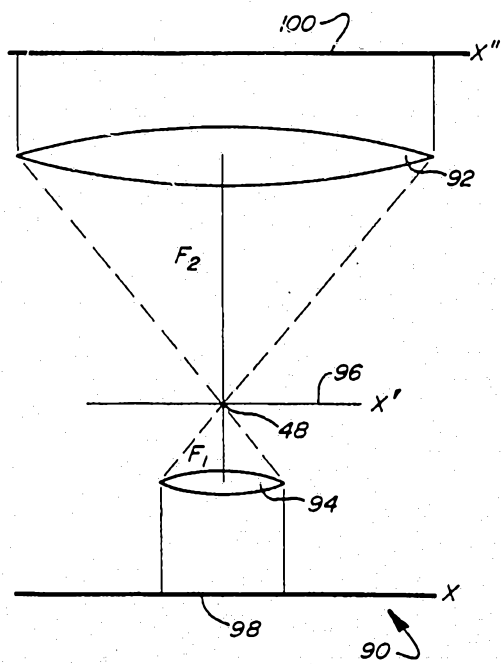

FIG. 8

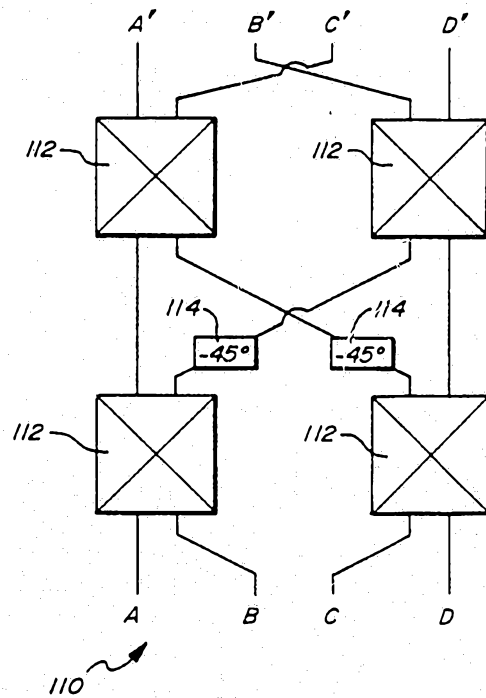

FIG. 9

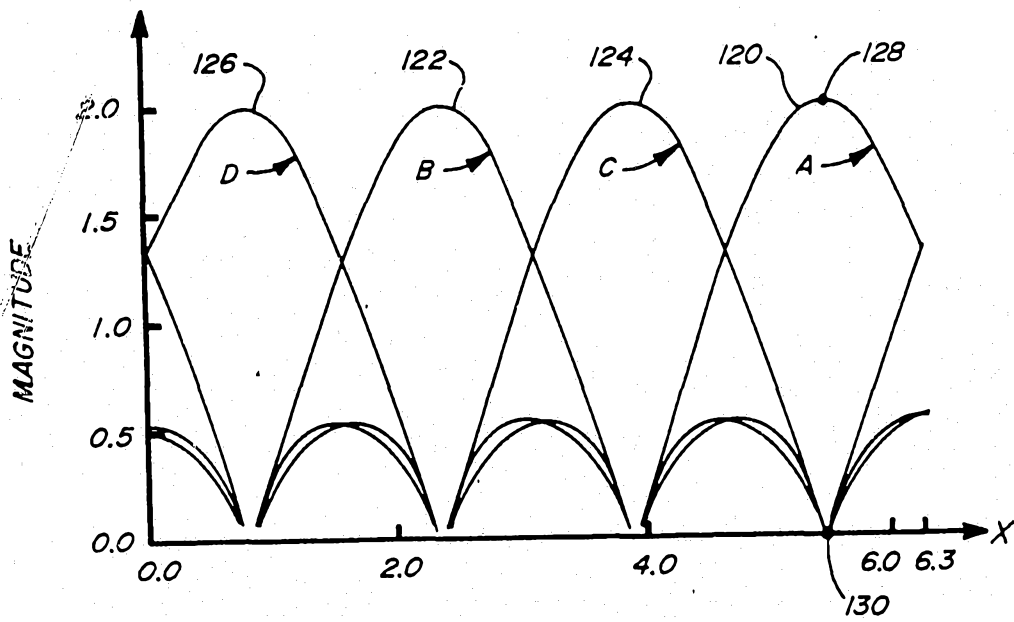
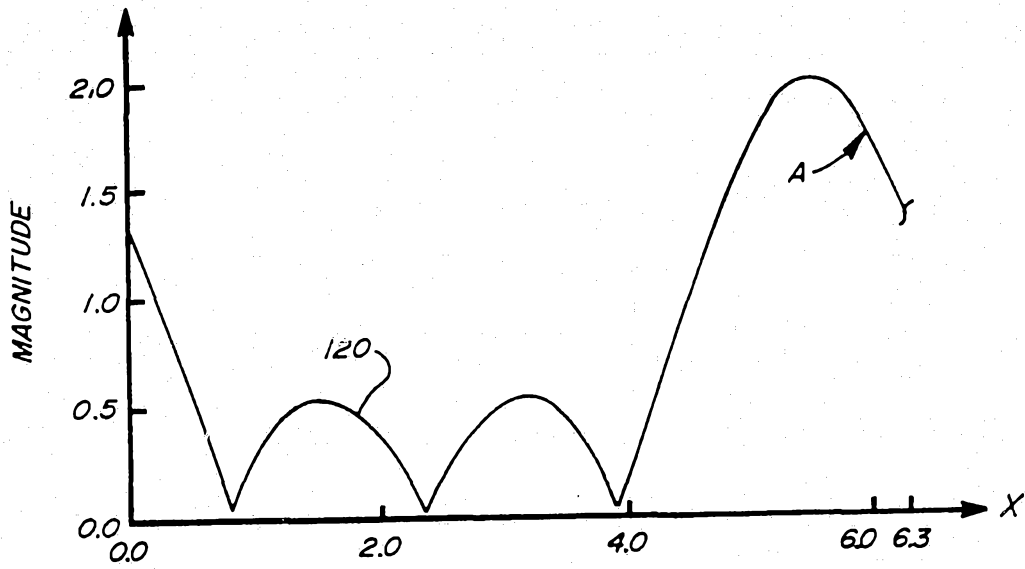

FIG. 10

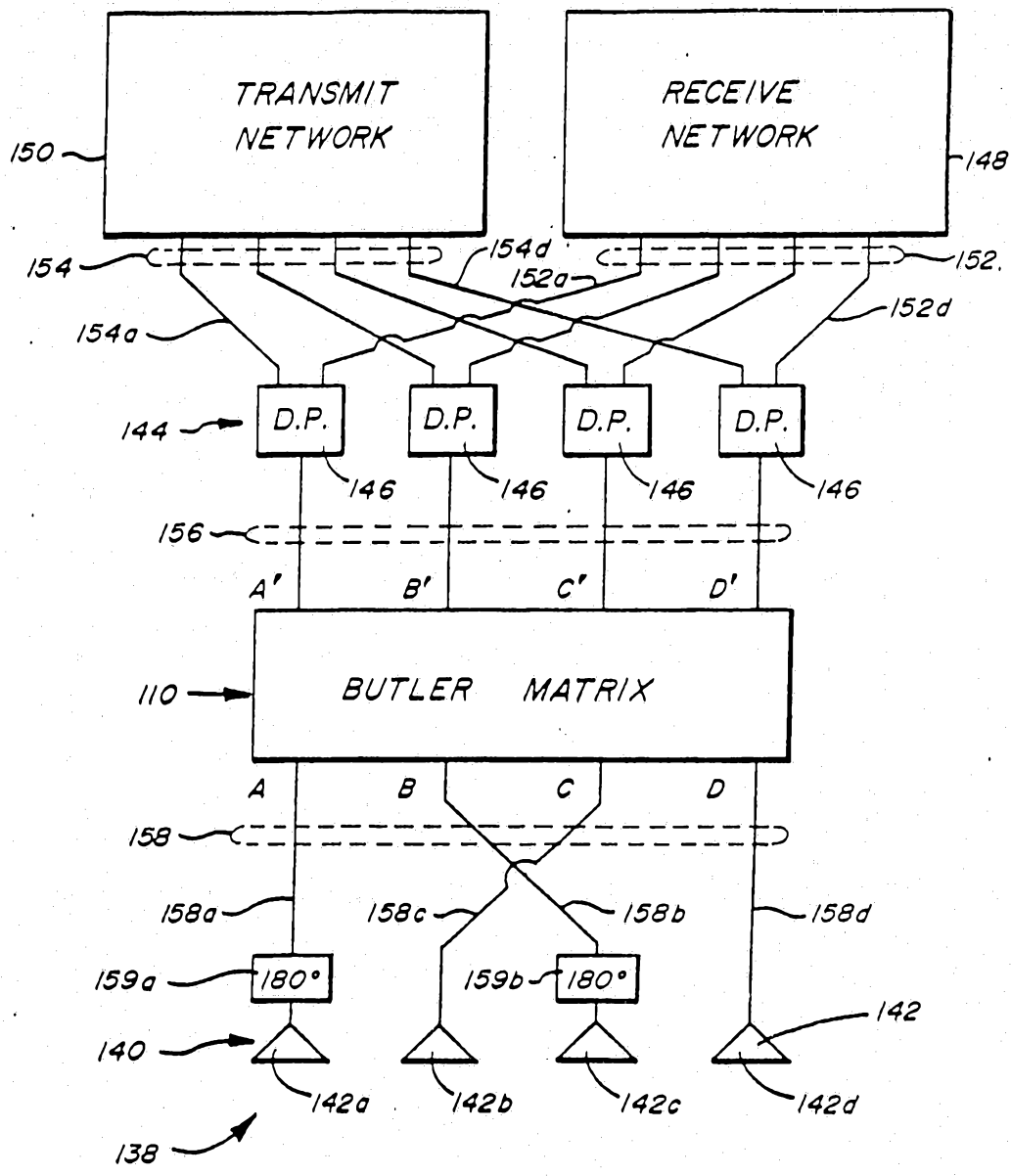

FIG. 11

FIG. 12

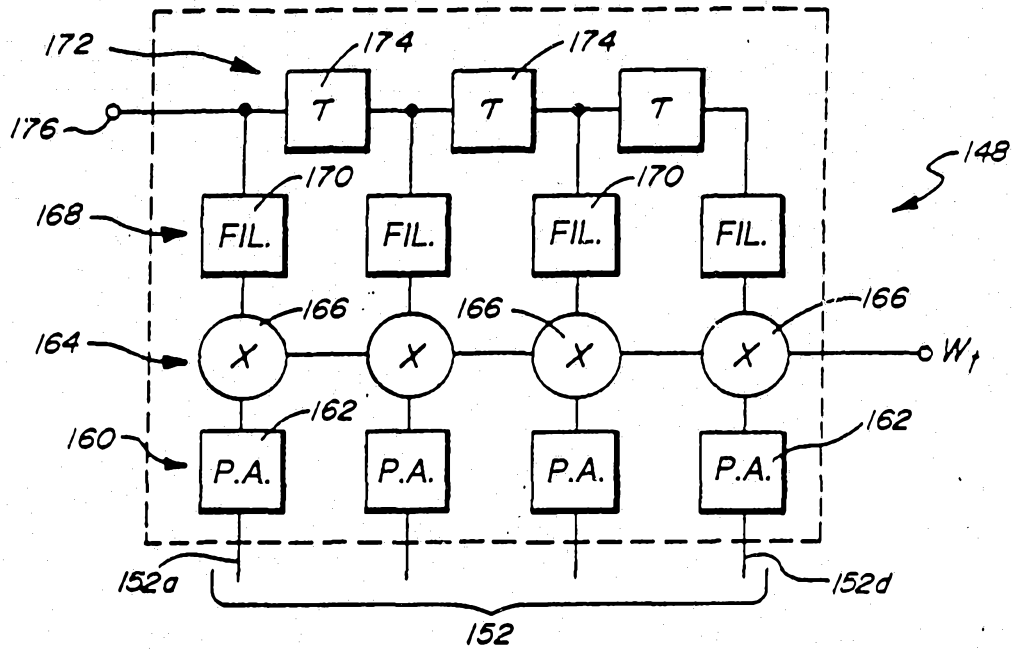
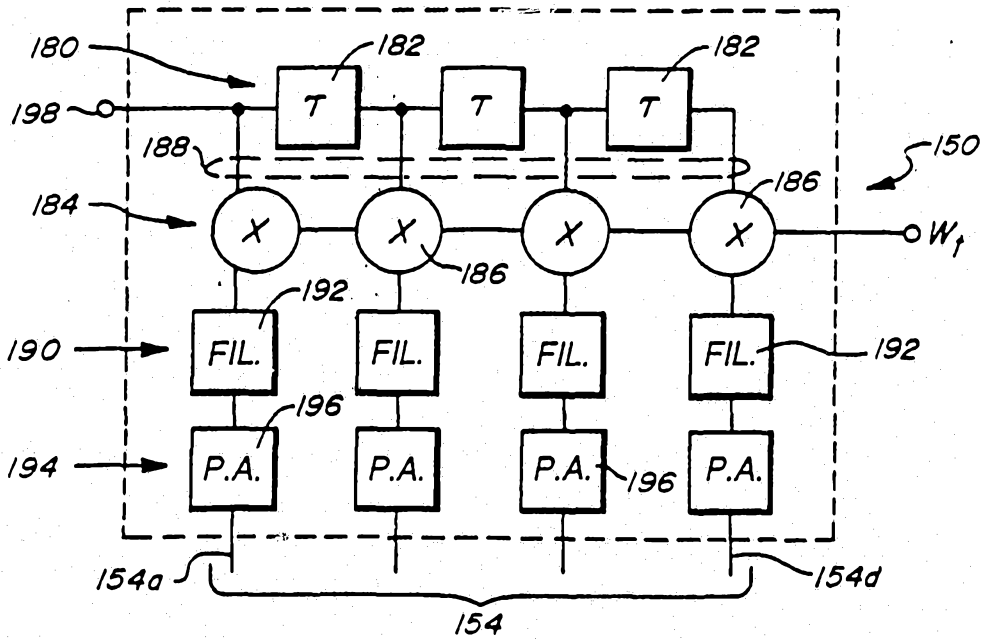

FIG. 13



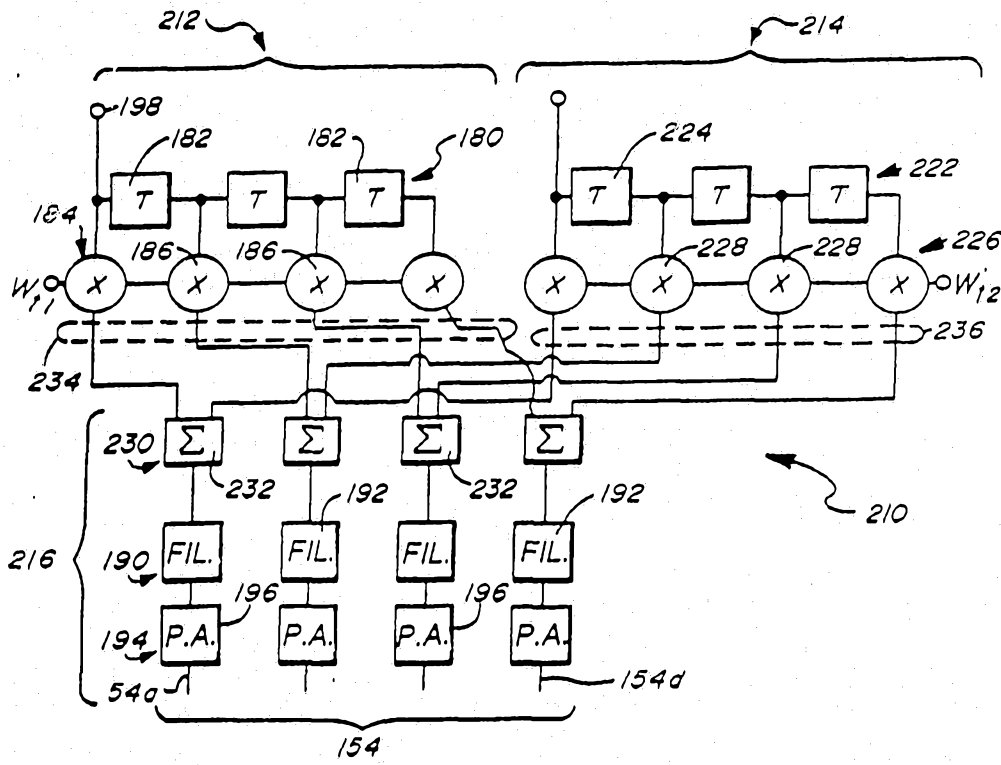

FIG. 14

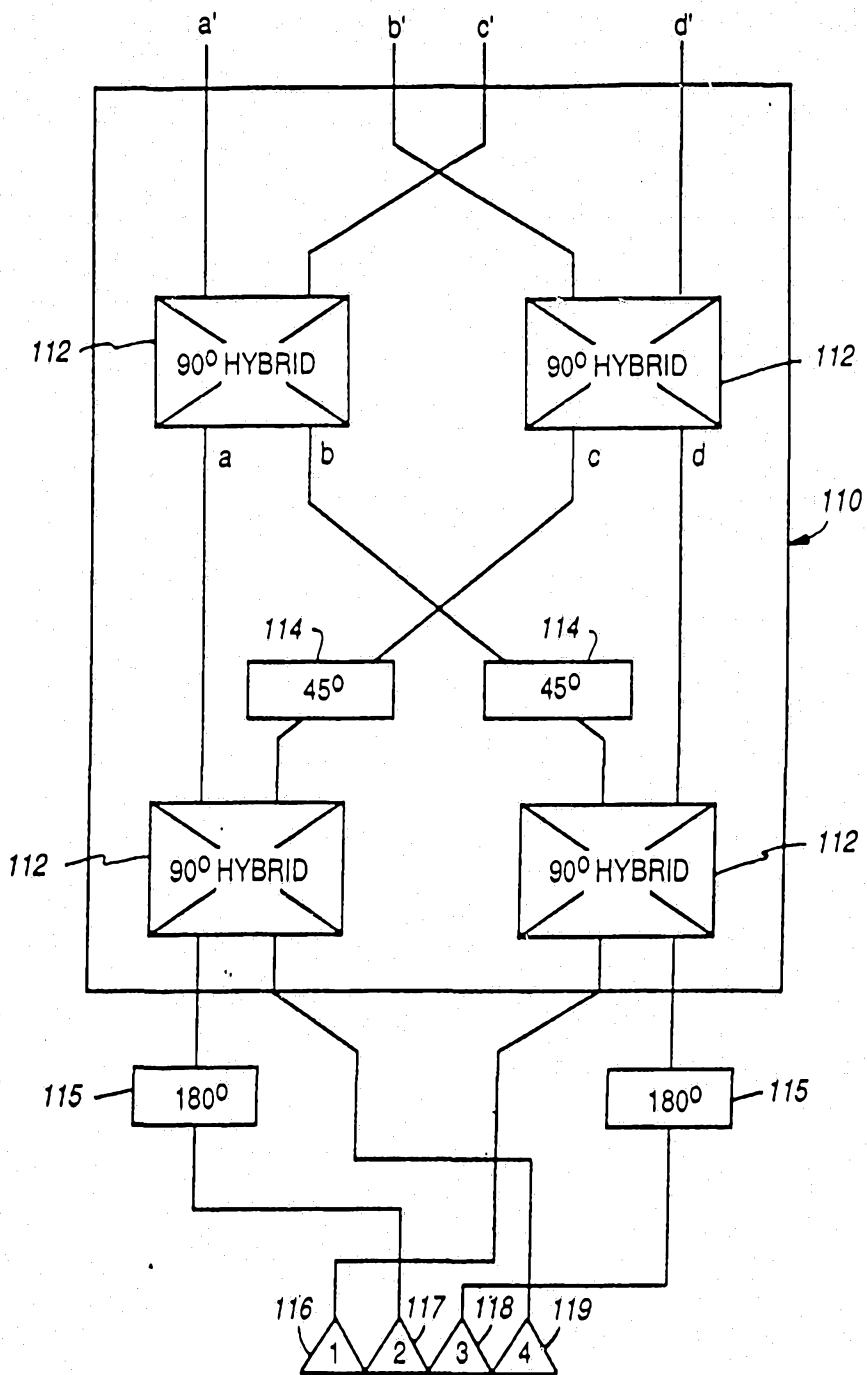

FIG. 15

FIG. 16 A

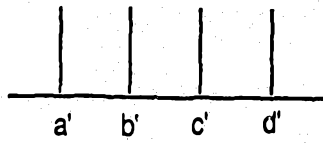

FIG. 16 B

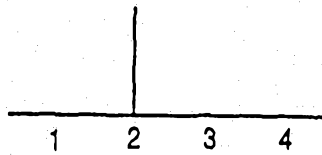

FIG. 16 C

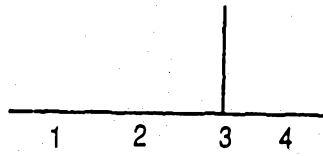

FIG. 16 D

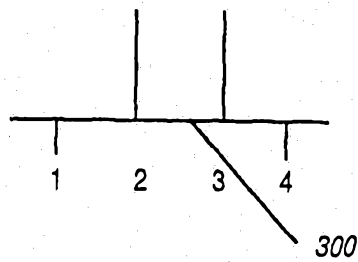
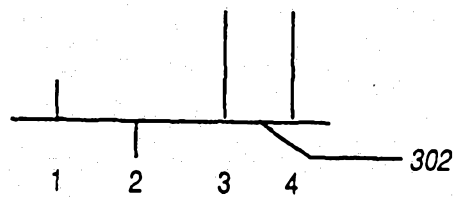

FIG. 16 E



64765/90

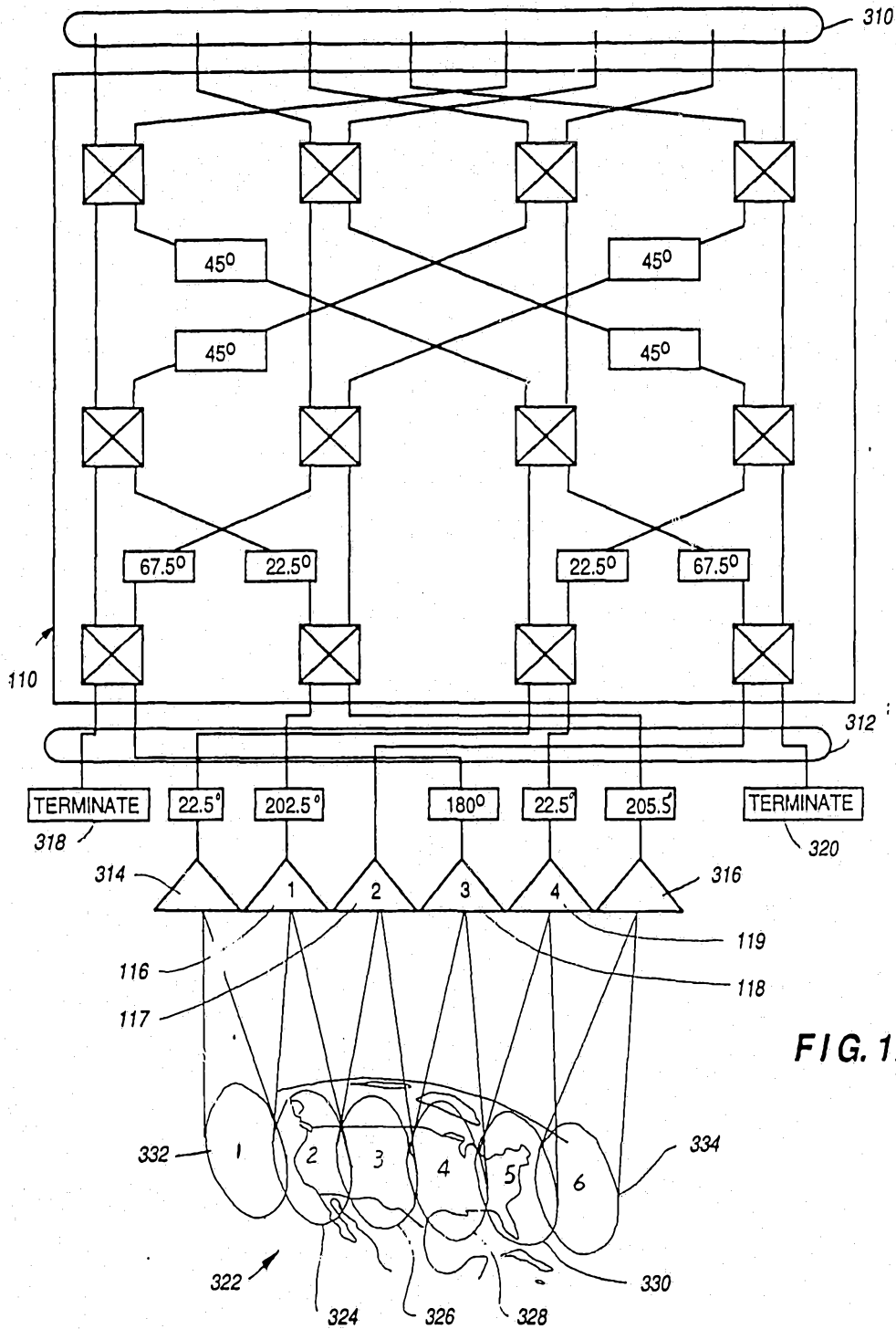

FIG. 17