

(Model.)

W. H. McCONNELL & F. A. RAY.
VENTILATING FAN.

No. 521,862.

Patented June 26, 1894.

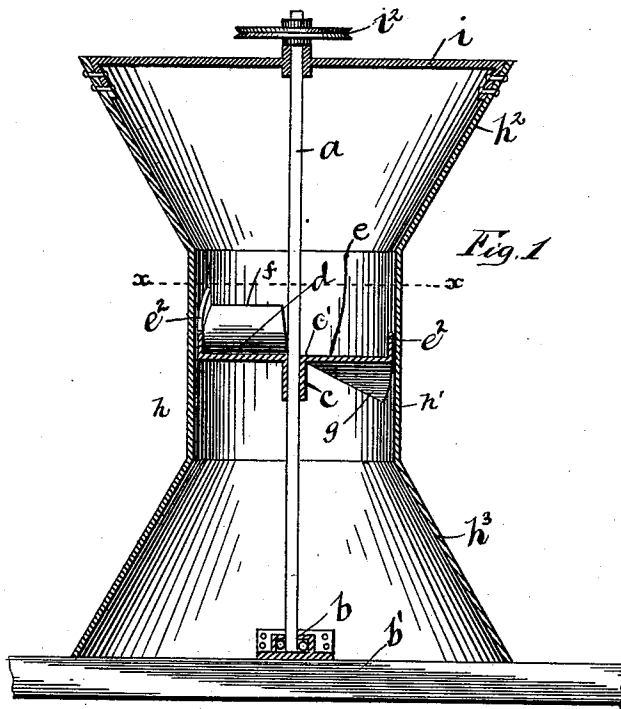

Fig. 2

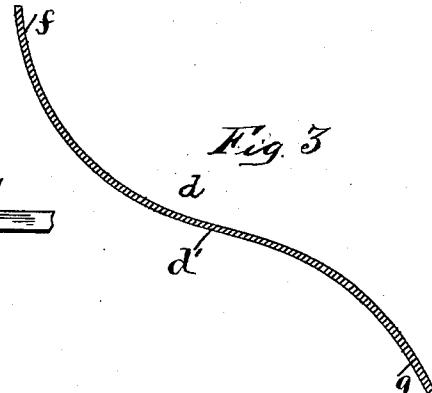
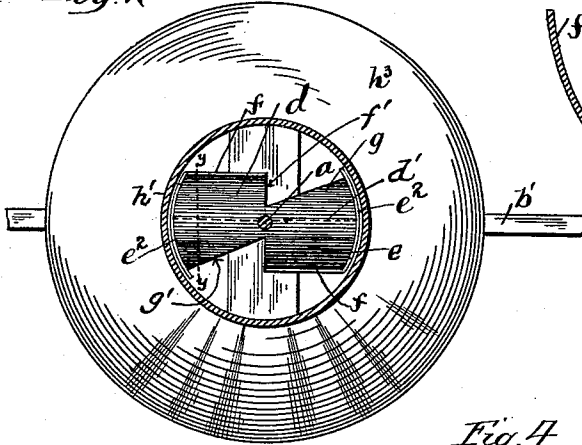
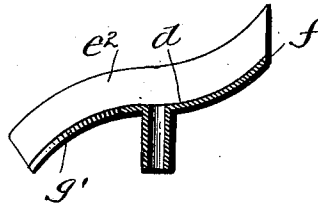

Fig. 4.



WITNESSES:

H. P. Bradshaw
E. C. Bragg

INVENTORS
William H. McConnell
Frank A. Ray.
BY
Staley and Shepherd.
ATTORNEYS

UNITED STATES PATENT OFFICE.

WILLIAM H. McCONNELL, OF NELSONVILLE, AND FRANK A. RAY, OF CONGO, OHIO.

VENTILATING-FAN.

SPECIFICATION forming part of Letters Patent No. 521,862, dated June 26, 1894.

Application filed August 24, 1892. Serial No. 443,965. (Model.)

To all whom it may concern:

Be it known that we, WILLIAM H. McCONNELL, of Nelsonville, in the county of Athens, and FRANK A. RAY, of Congo, in the county of Perry, State of Ohio, citizens of the United States, have invented a certain new and useful Improvement in Ventilating-Fans, of which the following is a specification.

Our invention relates to the improvement of ventilating fans of that class which are adapted for use in mines, buildings, &c.

The objects of our invention are to provide a fan of this class of superior construction and arrangement; to so form and construct the parts thereof as to decrease the friction between the air and fan case and greatly facilitate the production of a strong draft or suction; to admit of a large volume of air being propelled thereby with a comparatively small degree of power and to produce other improvements which will be more specifically pointed out hereinafter. These objects we accomplish in the manner illustrated in the accompanying drawings, in which—

Figure 1 is a central vertical section of our improved fan and case therefor. Fig. 2 is a transverse section of the same taken on line xx of Fig. 1 and Fig. 3 is an enlarged sectional view through one of the vanes taken on line yy of Fig. 2. Fig. 4 is a section through the fan body at right angles to the sectional line of Fig. 1, illustrating only one of the vanes.

Similar letters refer to similar parts throughout the several views.

a represents a shaft, the inner end of which is provided with any suitable socket or other bearing as indicated at b , said bearing being supported from a suitable cross-beam or frame piece b' . Upon this shaft a is rigidly secured in any desirable manner, the central sleeve or hub c of our improved fan wheel c' . As shown in the drawings, the body of this fan wheel is preferably formed of one piece of sheet or plate metal, said body being divided into two vanes which are indicated at d and e respectively. Each of the vanes d and e which project on opposite sides of the shaft a is bent longitudinally as shown, to form a double or compound curve as more plainly indicated in Fig. 3 of the drawings, which

forms what we shall term for the sake of clearness an upper and lower vane wing f and g at the rear and front end of the vane respectively. The rear wing f curves upwardly longitudinally of the vane, from a diametrical line d' (shown dotted in Fig. 2) which passes through the shaft a , and its rear end stands parallel with this line. The front wing g curves downwardly longitudinally of the vane, from this line d' to the front end of the vane and this end is formed on a line g' which is oblique to said diametric line d' and approximately follows a diametric line through shaft a at another angle. The inner edge f' of the rear wing is formed on a straight line at right angles with the line d' , although this edge as well as the outer edge partakes of the longitudinal double-curvature of the wing as shown in Fig. 3. The outer edge is struck on the arc of a circle, as shown in Fig. 2. The rear wing f rises higher above the longitudinal center of the vane than the front wing g depends below the same.

e^2 represents outer edge flanges which project upwardly as shown, from the outer edge of each of the vanes, said flanges being of uniform height and thus corresponding with the curves of said vanes.

h represents the fan case which as shown in the drawings, consists of a central vertical tubular portion h' within which said fan is adapted to rotate, and upper and lower flaring end portions h^2 and h^3 . The upper portion of the shaft a is provided with a journal bearing which may be formed in a cross-piece i at the upper end of the casing. Said shaft may also be provided with a suitable driving wheel indicated at i^2 . The case h may have its base supported upon the cross-beam b' or otherwise supported or suspended by suitable frame-work.

From the construction herein shown and described, it will be seen that when rotated, the forward downwardly pointed portions g of the fan vanes will in conjunction with the side flanges thereof, tend to produce a centripetal movement of the air caught by the vanes instead of the usual centrifugal movement by fans of this class. By this means it will be seen that the friction between the

moving air current and the inner walls of the case will be greatly reduced and that by thus creating a reduction in friction and consequently in resistance, a great reduction in the power required to operate said fan is attained. It will also be observed that the double curved or compound form of the vanes will result in a lifting or direct forcing of the air through the case rather than in the outward motion of said air current against the case.

Having now fully described our invention, what we claim, and desire to secure by Letters Patent, is—

1. In a ventilating fan, the combination with a cylindrical casing, and a rotating shaft concentric therein; of a fan body secured to said shaft and comprising two oppositely disposed vanes, each having its outer edge struck on the arc of a circle smaller than said casing, and its body formed into a double or compound curve on a line approximately parallel with said outer edge, as and for the purpose set forth.

2. In a ventilating fan, the combination with a cylindrical casing, and a rotating shaft concentric therein; of a fan body secured to said shaft and comprising two oppositely disposed vanes, each having its outer edge struck on the arc of a circle smaller than said casing and its body formed into a double or compound curve on a line approximately parallel with said outer edge and a flange rising from each of said outer edges and conforming with

the curvature of the vane, as and for the purpose set forth.

3. In a ventilating fan, the combination with a cylindrical casing, and a rotating shaft concentric therein; of a fan body secured to said shaft and comprising two oppositely disposed vanes, each having its body formed into a double or compound curve throughout its length in its direction of movement, thus producing rear and front wings, the rear wing rising higher above the longitudinal center of the vane than said front wing depends therefrom, substantially as described.

4. In a ventilating fan, the combination with a cylindrical casing, and a rotating shaft concentric therein; of a fan body secured to said shaft and comprising two oppositely disposed vanes, each having its body formed into a double or compound curve throughout its length in the direction of its movement, thus producing rear and front wings respectively rising above and depending below the central line of the vane, the rear end of the rear wing being parallel with said line, and the front end of the front wing being oblique to said line and approximately diametric with the central shaft, substantially as described.

WILLIAM H. McCONNELL,
FRANK A. RAY.

In presence of—

H. B. HINMAN,
ASHER BUCKLEY.