

(19)



Europäisches Patentamt

European Patent Office

Office européen des brevets



(11)

**EP 0 549 836 B1**

(12)

**EUROPEAN PATENT SPECIFICATION**

(45) Date of publication and mention of the grant of the patent:  
**10.07.1996 Bulletin 1996/28**

(51) Int Cl.<sup>6</sup>: **H04R 5/033**, H04S 1/00,  
H04S 3/00, H04N 13/04,  
H04R 27/00

(21) Application number: **91312109.1**

(22) Date of filing: **31.12.1991**

(54) **Multi-dimensional sound reproduction system**

Multidimensionales Tonwiedergabesystem

Système de reproduction sonore multi-dimensionnel

(84) Designated Contracting States:  
**DE ES FR GB IT**

(43) Date of publication of application:  
**07.07.1993 Bulletin 1993/27**

(73) Proprietor: **SONICS ASSOCIATES  
INCORPORATED**  
**Birmingham, Alabama 35244 (US)**

(72) Inventors:  
• **Scofield, William Clayton**  
**Birmingham, Alabama 35216 (US)**  
• **McCroskey, Lynn Allan**  
**Birmingham, Alabama 35223 (US)**

(74) Representative: **Lawrence, Malcolm Graham et al**  
**Hepworth, Lawrence, Bryer & Bizley**  
**Merlin House**  
**Falconry Court**  
**Bakers Lane**  
**Epping Essex CM16 5DQ (GB)**

(56) References cited:  
**EP-A- 0 284 286**                      **EP-A- 0 421 681**  
**FR-A- 2 006 116**                      **US-A- 4 110 583**  
**US-A- 4 952 024**                      **US-A- 4 967 268**  
**US-A- 4 993 074**

- **PATENT ABSTRACTS OF JAPAN** vol. 004, no. 121 (E-023)27 August 1980
- **FUNKSCHAU**, vol. 49, no. 10, May 1977, **MUNCHEN DE** pages 433 - 444; **TOSHIYA INOUE**: 'Lokalisierung von Schallereignissen - biphones/quadro-biphones Verfahren'

**EP 0 549 836 B1**

Note: Within nine months from the publication of the mention of the grant of the European patent, any person may give notice to the European Patent Office of opposition to the European patent granted. Notice of opposition shall be filed in a written reasoned statement. It shall not be deemed to have been filed until the opposition fee has been paid. (Art. 99(1) European Patent Convention).

## Description

The present invention pertains in general to a sound reproduction system, and more particularly, to a sound reproduction system for a multi-dimensional space using a binaural recording.

In stereophonic sound systems, such as those found in home entertainment applications, there is an attempt to control the localization of sounds typically using balance potentiometers. In this process, the relative level between two loudspeakers affects where the phantom image will exist as perceived by a listener positioned equidistant from two loudspeakers with respect to a single plane. The perception of where the sound originates, i.e., the phantom image, has also been observed to be a function of the delay between the two otherwise identical sources. For gradual increasing delays, which are on the order of the Interaural Time Difference (ITD) between the ears, the phantom image will shift toward the real undelayed source, which is disposed away from the phantom image. As the amount of delay is increased toward 10 mS, sound direction is "fused" to the speaker from which the sound first arrived. In fact, it has been observed that if two similar sounds, which originate from separate sources are delayed with respect to each other by an amount that is between 10 mS - 50 mS, a listener who is positioned equidistant from the two loudspeakers will perceive the sound to be coming from the direction of the speaker whose sound arrives first, to the exclusion of the second speaker. This has been referred to as the Law of the First Wavefront, the Precedence Effect or the Haas Effect.

For sound arriving from two different sources, be they reflections or delayed sources, the sound can either appear as an echo to an individual, or as just a mere coloration of the direct sound. If the delay between two identical sounds is separated in time by around 10 mS, the sound will be perceived as a coloration of the direct sound, whereas for delays greater than around 50 mS, the sound will be perceived as an echo. Therefore, if the delayed sound were directed toward the listener from a rearward position with a delay between 10-50 mS relative to the direct sound, the listener would not perceive the location of the rearmost sound source, but, rather, he would experience a fuller and perhaps more intelligible sound at his location. Essentially, the human ear tends to lock on sound which arrives first.

The above observations can generally be explained based on the theory that the position of a sound source is cued by interaural differences in the intensity and time of arrival (phase). This is the so-called duplex theory of localization which states that phase is the main mechanism of the localization below 1500 Hz, while for frequencies above around 4000 Hz, intensity is the main localization cue. For the intervening range of frequencies, localization is not good and it may be that confusion comes about because of conflict between the two mechanisms over this range of frequencies. The duplex the-

ory of localization will break down when it comes to defining unique sound source positions. A sound source which is located directly in front of a listener and one which is located directly behind a listener provides identical signals to the ears according to the duplex theory. However, it is a common everyday experience to discriminate between front and back localized sounds. There is much evidence to support the idea that a third mechanism contributes to the localization of sound, and that is the pinna transformation of sound.

Over the years, experiments have shown that the pinna performs a spectral modification which gives additional cues for the localization of sounds. This is particularly true with respect to elevation and front-back cues. The brain/nervous systems appears to process angular dependant spectral information in order to determine direction. This is due to the complex shape of the pinna which, when presented to a sound in front of the user, results in a significantly different response to the ear canal as compared to that for a sound originating from behind the listener. This spectral modification is also affected by the head and torso.

For multi-dimensional sound, typically referred to as 3-D sound, it is necessary to localize the sound, identify moving sound sources, enlarge the ideal listening area for the listener and remove the actual sound from a viewing area, such as a movie screen, to the individual. When considering only a single individual in a room, multi-dimensional sound has been reproduced through either headphones or through loudspeakers. With respect to the loudspeakers, it is important that the listener not move, since very complex systems have been developed which provide for cancellation of cross-talk between loudspeakers. Further, the rooms in which these experiments have been carried out typically are acoustically "dead" rooms.

One system that has been provided to reproduce binaural signals through loudspeakers is the Q-biphonic system. This system utilizes a binaural synthesizer that takes pre-recorded monaural sources and converts them into binaural signals along with loudspeaker cross-talk cancellation circuitry necessary for playback through loudspeakers. These systems claim to achieve full azimuthal localization in a four speaker system in addition to elevation localization. This system is very sensitive to head movement and is restricted to only one listening position. In the early days of this system, it was found that an anechoic space was needed.

Another solution proposed for a multi-dimensional system is one utilizing a multiple delay line system controlled by a personal computer. Provisions are made for six delay lines and an additional four non-delay lines. By utilizing a computer "mouse", which provides coordinate manipulation, sounds can be localized by controlling the signal arrival times between loudspeakers in a multiple speaker system. In addition to the adjustable delay, there is also an adjustable attenuation provided for each line. The individual delay times and attenuation calcula-

tions, which are accomplished on a computer, achieve the desired effect, i.e., phantom imaging. Delay times can be updated to account for moving sources through the use of the mouse, and preset configurations can be stored for future reference.

Some present research that is going on in the multi-dimensional sound system field is that for developing a multisensory "virtual environment" work station (VIEW) for use in space station teleoperation, tele-presence and automation activities. The auditory requirements for this project led to the prototyping of a binaural signal processor for converting generated or recorded sounds into binaural signals. Researchers measured a subject's pinna responses as a function of azimuth and elevation and arrived at pure head related transfer functions (HRTFs) using Fast Fourier Transform techniques. These HRTFs were implemented in a Digital Signal Processing (DSP) device which allowed the user to apply direction dependent equalization to an incoming signal. By establishing the proper relationship between the ITD, the Interaural Level Difference (ILD), and the HRTF, experimenters were able to synthesize free field stimuli and present this over headphones. Motion trajectories and static locations that represented greater resolution of HRTFs than measured were arrived at through interpolation. However, this system had some problems with front-back reversals.

To record binaural soundtracks, a recording system has been utilized that employs an artificial head for making the recordings. This is sometimes referred to as a "dummy" head. The system utilizes an artificial head that is fabricated from an anthropomorphic mannequin-like device that has lifelike pinnas and microphones disposed in the ear canals. The microphones are disposed on either side of the artificial head, and these microphones are utilized in conjunction with a binaural processor that converts the standard signals into binaural signals. The artificial head is typically utilized as an area microphone with additional circuitry provided for replicating the recordings of soloists which are converted and blended with the area recording.

In the recording process utilizing the artificial head, the head is equalized for a flat free-field response at frontal incidence. This accomplishes two things. First, the experience of listening to binaural recordings through headphones typically produces interior or "in-the-head" sounds. This is due to the disturbance of the conch resonance in the pinna by earphone cups, which causes a sense of nearness and "in the head" localization. The free-field equalization removes this resonance during recording, while for playback, the headphones are equalized to restore this resonance. It can be appreciated that the headphones destroy the natural conch resonance. The equalization of the response with the headphones results in better external localization, which is still because of the uniqueness of the transfer function of the pinna of each individual.

Secondly, the artificial head recordings made with

the free-field equalization will reproduce with good results through regular stereo equipment. Furthermore, if these binaural recordings are reproduced through loudspeakers utilizing cross-talk canalization (transaural listening), the conch resonance of the pinna is not presented twice, but is only restored by the natural action of the outer ear.

In U.S. Patent No. 4,817,149, issued March 28, 1989, a system is disclosed that enables sounds to be localized from all directions when played through headphones. Elevation and front/back cues are established utilizing direction-dependant filtering while horizontal (aximuthal) localization is achieved by control of interaural time difference.

U.S. -A-4110583 discloses apparatus in which localized speakers are supported in housings attached to the head by means of a support, the speakers being located forward of the left and right ears respectively and directed rearwardly towards the ears. The ears are enclosed, typically by the speaker housings, which has the disadvantage of disturbing the natural response of the ears.

JP-A-55077295 discloses the use of open type headphones in combination with an external woofer speaker in order to enhance stereophonic listening. The use of such headphones however has the disadvantage of distorting the natural response of the ears, making the apparatus unsuitable for reproducing binaural signals.

US-A-4993074 discloses a spacing device which holds earphones away from the ears of a listener. The speakers of the earphones however and the spacing device remain sufficiently close to the ears to disturb the natural response of the ears thereby making the apparatus unsuitable for reproducing binaural signals.

According to the present invention there is disclosed apparatus for reproducing binaural audio signals having first and second channels comprising;

(a) first and second localized speakers operable to reproduce first and second signals from the first and second channels respectively;

(b) a support comprising head engaging means for engaging a listener's head in use in fixed relationship thereto and at a location which does not enclose the ears or otherwise disturb the natural response of the ears;

(c) the support further comprising a left and right housing fixedly mounted to the head engaging means and supporting the first and second speakers respectively at positions such that in use the speakers are located forward of the left and right ears respectively and are directed rearwardly towards the left and right ears;

characterized in that the position of the speakers is such that in use the speakers are located proximate

to the left and right sides of the head such that cross talk between each of the first and second speakers and the right and left ears respectively is minimized due to attenuation of sound by the presence of the head; and in that the speakers are supported rearwardly of the respective housings such that the housings do not project rearwardly of the speakers so as not to disturb the natural response of the ears of the listener.

In a further embodiment of the present invention, the first and second localized speakers are supported in an eyeglass frame. The eyeglass frame is supported on the listener's head with a headband. Speaker housings are disposed on the headband to secure the localized speakers. The localized speakers are positioned such that they are directed rearward toward the pinna of the associated left and right ear and disposed proximate to the zygomatic arch of the listener.

The invention (and for comparison purposes the prior art) will be described, by way of example only, reference being made to the accompanying drawings, in which:-

FIGURES 1a and 1b illustrate diagrams of the prior art multi-dimensional sound systems;

FIGURE 2 illustrates a block diagram of the present invention;

FIGURE 3 illustrates a diagram of the present invention utilized with a plurality of listeners in an auditorium;

FIGURE 4 illustrates a detail of the orientation of the localized speakers;

FIGURE 5 illustrates a perspective view of the support mechanism for these speakers;

FIGURE 6 illustrates a side view of the housing and the localized speaker;

FIGURE 7 illustrates a detail rear perspective view of the housing for containing one of the localized speakers;

FIGURE 8 illustrates a schematic block diagram of the system for generating the localized speaker driving signals;

FIGURE 9 illustrates a schematic diagram for generating the signals for driving the localized speakers; and

FIGURE 10 illustrates a block diagram of an alternate method for transmitting the binaural signals to the listener over a wireless link.

Referring now to FIGURE 1a, there is illustrated a schematic diagram of a prior art system for recording and playing back binaural sound. The prior art system is divided into a recording end and a playback end. In the recording end, a dummy head 10 is provided which has microphones 12 and 14 disposed in place of the ear canals. Two artificial pinnae 16 and 18, respectively, are provided for approximating the response of the human ear. The output of each of the microphones 12 and 14 is fed through pre-filters 20 and 22, respectively, to a

plane 24, representing the barrier between the recording end and the playback end. The transfer function between the artificial ears 16 and 18 and the barrier 24 represents the first half of an equalizing system with the pre-filters 20 and 22 providing part of this equalization.

The playback end includes a listener 26 which has headphones comprised of a left earpiece 28 and a right earpiece 30. A correction filter 32 is provided between the barrier 24 and the earphone 28 and a correction filter 34 is provided between the barrier 24 and the earphone 30. The correction filter 34 is connected to the output of the pre-filter 20 and the correction filter 32 is connected to the output of the pre-filter 22. The transfer function between the barrier 24 and the earphone 30 represents the playback end transfer function. The product of the recording end transfer function and the playback end transfer function represents the overall transfer function of the system. The pre-filters 20 and 22 and the correction filters 32 and 34 provide an equalization which, when taken in conjunction with the response of the dummy head, should result in a true reproduction of the sound. It should be appreciated that the earphones 28 and 30 alter the natural response of the pinna for the listener 26, and therefore, the equalization process must account for this.

Referring now to FIGURE 1b, there is illustrated a diagrammatical representation of a prior art system, which is similar to the system of FIGURE 1a with the exception that speakers 38 and 40 replace the headphones 28 and 30 and associated correction filters 32 and 34. However, when headphones are replaced by speakers, one problem that exists is cross-talk between the two speakers, since the speakers are typically disposed a large distance from the ears of the listener. Therefore, sound emanating from speaker 40 can impinge upon both ears of the listener 26, as can sound emitted by speaker 38. Further, the room acoustics would also affect the sound reproduction in that reflections occur from the walls of the room.

Headphones, as compared to speakers, are usually equalized to a free field in that their transfer function ideally corresponds to that of a typical external ear when sound is presented in a free sound field directly from the front and from a considerable distance. This does not lend itself to reproduction from a loudspeaker. In general, loudspeakers will require some type of equalization to be performed at the recording end, but this will still result in distortions of tone and color. It can be seen that although the loudspeakers can be somewhat equalized with respect to a given position, the cross-talk of the speakers must be accounted for. However, when dealing with a large auditorium, this must occur for all the listeners at any given position, which is difficult at best.

Referring now to FIGURE 2, there is illustrated a diagram of the system of the present invention. The binaural recording is input to a signal conditioner 44 as a left and a right signal on lines 46 and 48, respectively. The signal conditioner 44, as will be described herein-

below, is operable to combine the left and the right signals for frequencies below 250 Hz and input them to low frequency speaker 52, there being no left or right distinctions made in the speaker 52. In addition, the left and right signals of lines 46 and 48 are output as separate signals on left and right lines 54 and 56 to localized speakers 58 and 60 which are disposed proximate to the ears of the listener 26. The localized speakers 58 and 60 are disposed such that they do not disturb the natural conch resonance of the ears of the listener 26, and they are disposed such that the sound emitted from either of the speakers 58 and 60 is significantly attenuated with respect to the hearing on the opposite side of the head. This is facilitated by disposing the localized speakers 58 and 60 proximate to the head such that the natural separation provided by the head will be maintained.

Only signals above 250 Hz are transmitted to the localized speakers 58 and 60. As will be described hereinbelow, a delay is provided to the sound emitted from localized speakers 58 and 60 as compared to that emitted from speaker 52, such that the sound emitted from speaker 52 will arrive at the location of the listener 26 at the approximate time that the sound is emitted from localized speakers 58 and 60, within plus and minus 12.5 ms. This accounts for the sound delay through the room and the distance of the listener 26 from the speaker 52. It has been noted that the important localization cues are not contained in the low frequency portion of the signal. Therefore, this low frequency portion of the audio spectrum is split out and routed to the listeners through the speaker 52. In this manner, the amount of sound energy that can be output at the low frequencies is increased, since the small size of the transducers that will be utilized for the localized speakers 58 and 60 cannot reproduce low frequency sounds with any acceptable fidelity.

Referring now to FIGURE 3, there is illustrated a diagram of the system utilized with a plurality of listeners 26. Each of the listeners 26 has associated therewith a set of localized speakers 58 and 60. The listeners 26 are disposed in a room 64 with the speaker 52 disposed in a predetermined and fixed location. Since it is desirable that sound from the speaker 52 arrive at all of the listeners 26 generally at the same time, the speaker 52 would be located some distance from the listeners 26, it being understood that Figure 3 is not drawn to scale. A viewing screen 65 is disposed in front of the listeners 26 to provide visual cues.

The localized speakers 58 and 60 are supported on the heads of listeners 26 such that they are maintained at a predetermined and substantially fixed position relative to the head. Therefore, if the head were to move when, for example, viewing a movie, there would be no phase change in the sound arriving at either of the ears of the listener 26. Therefore, a support member is provided which is affixed to the head of the listener 26 to support the localized speakers 58 and 60. In the pre-

ferred embodiment, groups consisting of six listeners are connected to common wires 54 and 56, such that the localized speakers 58 and 60 associated with each of the listeners 26 in a common group are connected to these wires, respectively. The sound level is adjusted such that each listener 26 will hear the sound at the appropriate phase from the associated one of the localized speakers 58 and 60. However, it has been determined experimentally that a listener 26 disposed in an adjacent seat with sound being emitted from his associated localized speakers 58 and 60 will not interfere with the sound received by the one listener 26. This is due to the fact that the sound levels are relatively low. If the localized speakers 58 and 60 are removed, then a listener 26 can hear sound emitted from localized speakers 58 and 60 among the listeners' seats adjacent thereto. The human ear "locks" onto the sound emitted from its associated localized speakers 58 and 60 and tends to ignore the sound from speakers disposed adjacent thereto. This is the result of many factors, including the Law of the First Wavefront described hereinbelow.

The combination of the localized speakers 58 and 60 and visual cues on the screen 65 provide an additional aspect to the listener's ability to localize sound. In general, the listener cannot localize sound very well when it is directly in front or in back of the listener's head. Some type of head movement or visual cue would normally facilitate localization of the sound. Since the localized speakers 58 and 60 are fixed to the listener's head, visual cues on the screen 65 provide the listeners 26 with additional information to assist in localizing the sound.

Referring now to FIGURE 4, there is illustrated a detail of the orientation of the localized speakers 58 and 60 relative to the listener 26. The localized speaker 58 is disposed proximate to the right ear of the listener and its associated pinna 66. Similarly, the localized speaker 60 is disposed proximate to the left ear of the listener 26 and the associated pinna 68. In the preferred embodiment, the localized speakers 58 and 60 are disposed forward of the pinnas 66 and 68, respectively, and proximate to the head of the listener 26. It has been determined experimentally that the optimum sound reproduction occurs when the speaker is directed rearward and disposed proximate to the zygomatic arch of the listener 26. If the associated localized speaker 58 or 60 is moved outward, directly to the side of the ear, the actual physical size of the speaker tends to disturb the conch resonance. However, if the speaker were reduced to an extremely small size, this would be acceptable.

It is important that the speaker not be moved too far from the listener, as cross-talk would occur. Of course, any type of separation in the front, the rear or on top of the head would improve this. The torso, of course, provides separation beneath the head, but it would be necessary to improve the separation in the space forward, rearward and upward of the head if the localized speakers 58 and 60 were moved away from the head. How-

ever, in the preferred embodiment, the localized speakers 58 and 60 are designed to be utilized in an auditorium with multiple users all receiving the same or similar signals. Therefore, they are disposed as close to the ear as possible without disturbing the conch resonance and to minimize the sound level necessary for output from the localized speakers 58 and 60.

Referring now to FIGURE 5, there is illustrated a perspective view of the support mechanism for the localized speakers 58 and 60. The localized speakers 58 and 60 are supported in a pair of three-dimensional glasses 70, which are designed for three-dimensional viewing. These glasses 70 typically have LCD lenses 72 and 74 which operate as shutters to provide the three-dimensional effect. A control circuit is disposed in a housing 76 which has a photo transistor 78 disposed on the frontal face thereof. The photo transistor 78 is part of a communications system that allows the synchronization signals to be transmitted to the glasses 70.

Housing 80 is disposed on one side of the glasses 70 for supporting the localized speaker 58. A housing 82 is disposed on the opposite side of the glasses 70 for supporting the localized speaker 60. The housings 80 and 82 provide the proper acoustic termination for the speakers 58 and 60, such that the frequency response thereof is optimized. The speakers 58 and 60 are typically fabricated from a dynamic loudspeaker, which is conventionally available for use in stereo headphones.

Referring now to FIGURE 6, there is illustrated a side view of the housing 82 and the localized speaker 60. The localized speaker 60, as described above, is disposed such that it is proximate to the side of the head in the area of the zygomatic arch. It is directed rearward toward the pinna 68 of the left ear of the listener 26 with the sound emitted therefrom being picked up by the pinna 68 and the ear canal of the left ear of the listener 26.

Referring now to FIGURE 7, there is illustrated a detailed view of the housing 82 and the speaker 60. The housing 82 is slightly widened at the mounting point for the localized speaker 60, which, as described above, is a small dynamic loudspeaker. A wire 84 is provided which is disposed through the housing 82 up to the control circuitry in the housing 76. Alternatively, the wire 84 can go to a separate control/driving circuit that is external to the housing 82 and the glasses 70. The housing 82 is fabricated such that it has a cavity disposed therein at the rear of the localized speaker 60. The size of this cavity is experimentally determined and is a function of the particular brand of dynamic loudspeaker utilized for the localized speakers 58 and 60. This cavity is determined by measuring the response of the particular dynamic loudspeaker with a variable cavity disposed on the rear side thereof. This cavity is varied until an acceptable response is achieved.

Referring now to FIGURE 8, there is illustrated a schematic block diagram of the system for driving the localized speakers 58 and 60 and also the low frequency

speaker 52. The binaural recording system typically provides an output from a tape recording, which is played back and output from a binaural source 90 to provide left and right signals on lines 92 and 94. These are input to a 4x4 circuit 96 that outputs left and right signals on lines 98 and 100 for localized speakers 58 and 60, and also a summed signal on a line 102, which comprises the sum of both the left and right signals. The 4x4 circuit 96 is manufactured by OXMOOR CORPORATION as a Buffer Amplifier and is operable to receive up to four inputs and provide up to four outputs as any combination of the four inputs or as the buffered form of the inputs. The signal line 102 is output to a crossover circuit 112 which is essentially a low pass filter. This rejects all signals above approximately 250 Hz. The crossover circuit 112 is typical of Part No. AC 22, which is a stereo two-way crossover, manufactured by RANE CORPORATION. The output of the crossover 112 is input to a digital control amplifier (DCA) 108 to control the signal level. This is controlled by volume level control 110. The DCA 108 is typical of Part No. DCA-2, manufactured by OXMOOR CORPORATION. The output of the DCA 108 is input to an amplifier 114 which drives the speaker 52 with the low frequency signals. The amplifier 114 is typical of Part No. 800X, manufactured by SONICS ASSOCIATES, INCORPORATED.

The left and right signals on lines 98 and 100 from the 4x4 circuit 96 are input to a delay circuit 106, which is typical of Part No. DN775, which is a Stereo Mastering Digital Delay Line, manufactured by KLARK-TEKNIK ELECTRONICS INC. The outputs of the delay circuit 106 are input to a high pass filter 118 to reject all frequencies lower than 250 Hz. The high pass filter 118 is identical to the part utilized for the crossover circuit 112. The outputs of filter 118 are input to a headphone mixer 120 to provide separate signals on a multiplicity of lines 122, each set of lines comprising a left and a right line for an associated set of localized speakers 58 and 60 for listeners 26. This is typical of Part No. HC-6, which is a headphone console, manufactured by RANE CORPORATION. The lines 122 are routed to particular listeners' localized speakers 58 and 60.

Referring now to FIGURE 9, there is illustrated a detailed schematic diagram of the circuit for driving the headphones. Line 98 is input through delay 106, and high pass filter 118 to the wiper of a volume control 124, the output of which is input to the positive input of an operational amplifier (op amp) 126. The output of op amp 126 is connected to a node 128 which is also connected to the base of both an NPN transistor 130 and a PNP transistor 132. Transistors 130 and 132 are configured in a push-pull configuration with the emitters thereof tied together and to an output terminal 134. The collector of transistor 130 is connected to a positive supply and the collector of transistor 132 is connected to a negative supply. The emitters of transistors 130 and 132 are also connected through a resistor 136 to the node 128. The negative input of the op amp 126 is connected

through a resistor 138 to ground and also through a feedback resistor 140 to the output terminal 134.

An op amp 142 is provided with the positive input thereof connected to the output of volume control 125. The wiper of volume control 125 is connected through delay 106 and the filter 118. Op amp 142 is configured similar to op amp 126 with an associated NPN transistor 144 and PNP transistor 146, configured similar to transistors 130 and 132. A feedback resistor 148 is provided, similar to the resistor 140, with feedback resistor 148 connected to the negative input of op amp 142 and an output terminal 150. A resistor 152 is connected to the negative input of op amp 142 and ground. The volume controls 124 and 125 provide individual volume control by the listener 26.

Line 98 is also illustrated as connected through a summing resistor 156 to a summing node 158. Similarly, the line 100 is connected through a summing resistor 160 to the summing node 158. The summing node 158 is connected to the negative input of an op amp 162, the positive input of which is connected to ground through a resistor 164. The negative input of op amp 162 is connected to the output thereof through a feedback resistor 166. Op amp 162 is configured for unity gain at the first stage. The output of op amp 162 is connected through a resistor 170 to a negative input of an op amp 172. The negative input of op amp 172 is also connected to the output thereof through a resistor 174. The positive input of op amp 172 is connected to ground through a resistor 176. Op amp 172 is configured as a unity gain inverting amplifier. The output of op amp 172 is connected to an output terminal 178 to provide the sum of the left and right channels. The op amps 162 and 172 provide the function of the summing portion of 4x4 circuit 96, and are provided by way of illustration only.

Referring now to FIGURE 10, there is illustrated a block diagram of an alternate method for transmitting the left and right signals to the localized speakers 58 and 60. The binaural source has electronic signals modulated onto a carrier by a modulator 180, the carrier then transmitted by transmitter 182 over a data link 184. The data link 184 is comprised of an infrared data link that has an infrared transmitting diode 185 disposed on the transmitter 182. A receiver 186 is provided with a receiver Light Emitting Diode 188 that receives the transmitted carrier from the diode 185. The output of the receiver 186 is demodulated by a demodulator 190 and this provides a left and right signal for input to the conditioning circuit 44.

In summary, there has been provided a multi-dimensional sound reproduction system. The system is comprised of two localized speakers which are supported in a substantially fixed relationship with respect to the head of a listener. The localized speakers are disposed proximate to the ear in such a position that they do not disturb the natural response of the ear, and sufficiently close to the head such that the cross-talk between each of the speakers and the opposite ear is min-

imized. Low frequency sound that does not contain important localization cues is filtered from the original binaural recording, and this is transmitted to the listener by an external speaker.

## Claims

1. Apparatus for reproducing binaural audio signals having first and second channels (92,94) comprising;

(a) first and second localized speakers (60,58) operable to reproduce first and second signals from the first and second channels respectively;

(b) a support (70) comprising head engaging means for engaging a listener's head (26) in use in fixed relationship thereto and at a location which does not enclose the ears (68,66) or otherwise disturb the natural response of the ears;

(c) the support further comprising a left and right housing (82,80) fixedly mounted to the head engaging means and supporting the first and second speakers respectively at positions such that in use the speakers are located forward of the left and right ears respectively and are directed rearwardly towards the left and right ears;

characterized in that the position of the speakers (60,58) is such that in use the speakers (60,58) are located proximate to the left and right sides of the head (26) such that cross talk between each of the first and second speakers (60,58) and the right and left ears (68,66) respectively is minimized due to attenuation of sound by the presence of the head (26); and in that the speakers are supported rearwardly of the respective housings such that the housings do not project rearwardly of the speakers so as not to disturb the natural response of the ears (26) of the listener.

2. Apparatus as claimed in claim 1 further comprising:

at least one external speaker (52);  
a filter circuit (112) for extracting a predetermined portion of the frequency spectrum of at least one of the first and second channels of the audio signal; and  
a mixing circuit (96) for outputting the extracted portion of the frequency spectrum from the at least one of the first and second channels of the audio signals to drive said speaker (52).

3. Apparatus as claimed in claim 2 wherein said filter circuit is operable to extract the predetermined portion of the frequency spectrum from both of the first and second channels of the audio signal, and said mixer is operable to combine the extracted portion of the frequency spectrum of the first and second channels of the audio signal into a monaural signal for output on said external speaker (52).
4. Apparatus as claimed in any of claims 2 and 3 wherein the portion of the frequency spectrum of the first and second channels of the audio signal extracted by said filter circuit (122) comprise the low frequency end of the frequency spectrum of the first and second channels of the audio signal.
5. Apparatus as claimed in any preceding claim wherein said first and second speaker housings secure and orient said associated first and second localized speakers (60,58), respectively, such that they are directed rearward toward the associated one of pinnas of the associated one of the left and right ears of the listener and slightly forward thereof.
6. Apparatus as claimed in any preceding claim wherein said first and second localized speakers (60,58) are supported by said associated first and second speaker housings, respectively, such that they are disposed proximate to the zygomatic arch of the listener on the associated side of the listener's head.
7. Apparatus as claimed in any preceding claim wherein each of said first and second speaker housings includes a cavity for being disposed about the rear of said associated first and second localized speakers to provide the proper acoustic termination for said associated first and second localized speakers.
8. Apparatus as claimed in any preceding claim and further comprising a display device (65) for outputting visual cues to the listener which, in conjunction with the audio signals, enhances the listener's ability to localize sound reproduced by said first and second localized speakers.
9. Apparatus as claimed in any preceding claim further comprising:
- an audio signal source (90) for generating the first and second channels of the audio signals on first and second outputs (92,94); and  
a communication link (184) for connecting the first and second outputs of said audio signal source to said first and second localized speakers.
10. Apparatus as claimed in claim 9 wherein said communication link comprises a wireless communication link.
11. A method of reproducing binaural audio signals housing first and second channels comprising the steps of;
- (a) attaching a support (70) to a listeners' head (26) by operation of an engaging means of the support so as to engage the head in fixed relationship thereto and at a location which does not enclose the ears (68,66) or otherwise disturb the natural response of the ears;
- (b) mounting first and second localized speakers (60,58) in housings (82,80) fixedly mounted to the head engaging means such that the first and second speakers are supported at positions forward of the left and right ears (68,66) respectively and are directed rearwardly towards the left and right ears (68,66); and
- (c) operating the first and second speakers (60,58) to reproduce first and second signals from the first and second channels respectively; characterized by positioning the speakers (60,58) is such that in use the speakers are located proximate to the left and right sides of the head (26) such that cross talk between each of the first and second speakers (60,58) and the right and left ears (68,66) respectively is minimized due to attenuation of sound by the presence of the head; and by supporting the speakers (60,58) rearwardly of the respective housings such that the housings (82,80) do not project rearwardly of the speakers so as not to disturb the natural response of the ears (68,66) of the listener.
12. A method as claimed in claim 11 further comprising:
- extracting a predetermined portion of the frequency spectrum from at least one of the first and second channels of the audio signal;
- providing an external speaker (52); and
- outputting the extracted portion of the frequency spectrum of the first or second channel of the audio signal to the speaker.
13. A method as claimed in claim 12 wherein the step of extracting is operable to extract the predetermined portion of the frequency spectrum from both the first and second channels of the audio signal.
14. A method as claimed in any of the claims 12 and 13 extracted portion comprises the lower end of the frequency spectrum that extends from a predetermined frequency point downward in frequency.

15. A method as claimed in any of claims 11 to 14 wherein the first and second localized speakers (60,58) are disposed proximate to the zygomatic arch of the listener.
16. A method as claimed in any of claims 11 to 15 comprising outputting visual cues to the listener which, in conjunction with the audio signal, enhance the listener's ability to integrate the visual and auditory cues.
17. A method as claimed in any of claims 11 to 16 further comprising:
- generating the audio signals on the first and second channels; and  
transmitting the audio signals over a communication link to the first and second localized speakers (60,58).
18. A method as claimed in claim 17 wherein the communication link is a wireless communication link.
19. A method as claimed in any of claims 11 to 18 wherein the audio signals are a binaural recordings.

#### Patentansprüche

1. Einrichtung zur Wiedergabe binauraler Audiosignale mit ersten und zweiten Kanälen (92, 94), bei der
- (a) erste und zweite lokal fixierte Lautsprecher (60, 58) so betrieben werden können, daß sie erste und zweite Signale von den ersten und zweiten Kanälen wiedergeben;
- (b) ein Träger (70) Mittel zur festen Anordnung des Kopfes (26) des Hörers in Bezug zum Träger und an einer Stelle, die die Ohren (68, 66) nicht einschließt oder sonstwie das natürliche Erfinden der Ohren stört, vorgesehen ist;
- (c) wobei der Träger ein linkes und ein rechtes Gehäuse (82, 80) enthält, die fest an dem Mitteln zur Anordnung des Kopfes befestigt sind, und die ersten und zweiten Lautsprecher an Stellen tragen, daß bei der Benutzung der Lautsprecher diese vor den rechten und linken Ohren angeordnet sind und nach hinten zu den linken und rechten Ohren gerichtet sind,
- dadurch gekennzeichnet, daß die Stellung der Lautsprecher (60, 58) derart ist, daß bei der Benutzung die Lautsprecher (60, 58) nahe der linken und rechten Seiten des Kopfes (26) derart angeordnet sind, daß das Übersprechen zwischen den ersten und zweiten Lautsprechern (60, 58) und der rechten

und linken Ohren (68, 66) aufgrund Dämpfung des Schalls durch den Kopf (26) minimiert ist, und derart, daß die Lautsprecher nach rückwärts der entsprechenden Gehäuse derart angeordnet sind, daß die Gehäuse von den Lautsprechern nicht zurückstehen, um das natürliche Empfinden der Ohren (26) des Hörers nicht zu beeinträchtigen.

2. Einrichtung nach Anspruch 1, bei der ferner wenigstens ein externer Lautsprecher (52) vorgesehen ist; bei dem eine Filterschaltung (112) zur Extrahierung eines bestimmten Teils des Frequenzspektrums aus wenigstens einem der ersten und zweiten Kanäle des Audiosignals vorhanden ist; und eine Mischschaltung (96) vorgesehen ist, um den extrahierten Teil des Frequenzspektrums aus den wenigstens ersten und zweiten Kanälen des Audiosignals abzugeben, um den Lautsprecher (52) zu betreiben.
3. Einrichtung nach Anspruch 2, bei der die Filterschaltung so betreibbar ist, daß der festgelegte Teil des Frequenzspektrums sowohl aus den ersten und zweiten Kanälen des Audiosignals herausgeseibt wird und der Mischer so betreibbar ist, daß er den extrahierten Teil des Frequenzspektrums der ersten und zweiten Kanäle des Audiosignals in ein monaurales Signal zur Ausgabe an den externen Lautsprecher (52) kombiniert.
4. Einrichtung nach einem der Ansprüche 2 und 3, bei der der Teil des Frequenzspektrums der ersten und zweiten Kanäle des Audiosignals, der durch die Filterschaltung (112) extrahiert ist, das niedrige Frequenzband des Frequenzspektrums der ersten und zweiten Kanäle des Audiosignals bildet.
5. Einrichtung nach einem der vorhergehenden Ansprüche, bei der die ersten und zweiten Lautsprechergehäuse die ersten und zweiten lokal fixierten Lautsprecher (60, 58) sichern und derart orientieren, daß diese nach hinten gegen die Hörmuscheln der zugehörigen linken und rechten Ohren des Hörers und etwas vorwärts davon gerichtet sind.
6. Einrichtung nach einem der vorhergehenden Ansprüche, bei der die ersten und zweiten lokal fixierten Lautsprecher (60, 58) durch die ersten und zweiten Lautsprechergehäuse in der Weise gehalten sind, daß diese nahe dem Jochbogen des Hörers auf der entsprechenden Seite des Kopfes des Hörers angeordnet sind.
7. Einrichtung nach einem der vorhergehenden Ansprüche, bei der die ersten und zweiten Lautsprechergehäuse einen Hohlraum aufweisen, der etwas hinter den entsprechenden ersten und zweiten lokal fixierten Lautsprechern angeordnet ist, um einen

geeigneten akustischen Abschluß der ersten und zweiten Lautsprecher zu bewirken.

8. Einrichtung nach einem der vorhergehenden Ansprüche, bei der weiter eine Displayanordnung (65) zur Ausgabe von visuellen Marken vorgesehen ist, die in Verbindung mit den Audiosignalen die Möglichkeit des Hörers verbessert, den durch die ersten und zweiten Lautsprecher ausgegeben Schall zu lokalisieren.

9. Einrichtung nach einem der vorhergehenden Ansprüche, bei der ferner eine Audiosignalquelle (90) zur Erzeugung der ersten und zweiten Kanäle der Audiosignale auf den ersten und zweiten Ausgängen (92, 94) enthält und eine Kommunikationsverbindung (184) vorgesehen ist, um die ersten und zweiten Ausgänge der Audiosignalquelle an die ersten und zweiten Lautsprecher auszugeben.

10. Einrichtung nach Anspruch 9, bei der die Kommunikationsverbindung eine drahtlose Kommunikationsverbindung bildet.

11. Verfahren zur Wiedergabe von binauralen Audiosignalen mit ersten und zweiten Kanälen, das die folgenden Schritte aufweist:

(a) Anordnen eines Trägers (70) am Kopf (26) des Hörers durch Anordnen des Haltermittels des Trägers in der Weise, daß der Kopf sich in fester Beziehung an einer Stelle befindet, und an einer Stelle, die die Ohren (64, 66) nicht enthält oder sonstwie das natürliche Empfinden der Ohren stört;

(b) Befestigen von ersten und zweiten lokal fixierten Lautsprechern (60, 58) in Gehäusen (82, 80), die fest an den Kopfhaltermitteln in der Weise angeordnet sind, daß die ersten und zweiten Lautsprechern in Stellungen gehalten sind, die vor den linken und rechten Ohren (68, 66) vorgesehen sind und nach rückwärts gegen die linken und rechten Ohren (68, 66) gerichtet sind; und

(c) Betreiben der ersten und zweiten Lautsprecher (60, 58), um erste und zweite Signale aus den ersten und zweiten Kanälen zu erzeugen; gekennzeichnet durch die Schritte, daß die Lautsprecher (60, 58) in der Weise angeordnet werden, daß bei der Benutzung die Lautsprecher diese nahe dem linken und rechten Seiten des Kopfes (26) derart angeordnet sind, daß das Übersprechen zwischen den ersten und zweiten Lautsprechern (60, 58) und der rechten und linken Ohren (68, 66) aufgrund Dämpfung des Schalls durch das Vorhandensein des Kop-

fes minimiert ist; und daß die Lautsprecher (60, 58) nach rückwärts bezüglich der Gehäuse in der Weise befestigt sind, daß die Gehäuse nicht von den Lautsprechern nach hinten vorstehen, um das natürliche Empfinden der Ohren (68, 66) des Hörers nicht zu stören.

12. Verfahren nach Anspruch 11, das ferner umfaßt: Extrahieren eines bestimmten Teils des Frequenzspektrums aus den ersten und zweiten Kanälen des Audiosignals; Vorsehen eines externen Lautsprechers (52); und Ausgabe des extrahierten Teils des Frequenzspektrums des ersten und zweiten Kanals des Audiosignals an den Lautsprecher.

13. Verfahren nach Anspruch 12, bei dem der Schritt des Extrahierens derart durchführbar ist, daß ein bestimmter Teil des Frequenzspektrums sowohl der ersten als auch zweiten Kanäle des Audiosignals extrahiert wird.

14. Verfahren nach einem der Ansprüche 12 und 13, bei dem der extrahierte Teil das untere Frequenzspektrumende bildet, das sich von einem bestimmten Frequenzpunkt in der Frequenz nach unten erstreckt.

15. Verfahren nach einem der Ansprüche 11 - 14, bei dem die ersten und zweiten lokal fixierten Lautsprecher (60, 58) nahe dem Jochbogen des Hörers angeordnet sind.

16. Verfahren nach einem der Ansprüche 11 - 15, das die Ausgabe visueller Marken an den Hörer enthält, die in Verbindung mit dem Audiosignal die Möglichkeit des Hörers verbessern, visuelle und Audiomarken zu integrieren.

17. Verfahren nach einem der Ansprüche 11 - 16, das ferner die Erzeugung von Audiosignalen an den ersten und zweiten Kanälen enthält und die Übertragung der Audiosignale über eine Kommunikationsverbindung zu den ersten und zweiten lokal fixierten Lautsprechern (60, 58) enthält.

18. Verfahren nach Anspruch 17, bei dem die Kommunikationsverbindung eine drahtlose Kommunikationsverbindung ist.

19. Verfahren nach einem der Ansprüche 11 - 18, bei dem die Audiosignale binaurale Aufzeichnungen sind.

## Revendications

1. Dispositif pour reproduire des signaux audio binaurales possédant des premier et second canaux

(92, 94) comprenant :

(a) des premier et second hauts-parleurs localisés (60,58) aptes à fonctionner pour reproduire des premier et second signaux provenant respectivement des premier et second canaux; (b) un support (70) comprenant des moyens d'engagement de la tête, permettant l'engagement de la tête (26) d'un auditeur, dans une relation fixe par rapport à ce dernier, en fonctionnement, et dans une position telle qu'il n'enserme pas les oreilles (66,68) ni ne perturbe d'une autre manière la réponse naturelle des oreilles; (c) le support comprenant en outre des boîtiers gauche et droit (82,80) montés de façon fixe sur les moyens d'engagement de la tête et supportant les premier et second hauts-parleurs respectivement dans des positions telles qu'en fonctionnement les hauts-parleurs sont situés respectivement en avant des oreilles gauche et droite et sont dirigés vers l'arrière en direction des oreilles gauche et droite;

caractérisé en ce que la position des hauts-parleurs (60,58) est telle qu'en fonctionnement, les hauts-parleurs (60,58) sont situés à proximité des côtés gauche et droit de la tête (26) de sorte qu'une diaphonie respectivement entre chacun des premier et second hauts-parleurs (60,58) et les oreilles droite et gauche (68,66) est réduite sous l'effet de l'atténuation du son due à la présence de la tête (26); et en ce que les hauts-parleurs sont supportés en arrière des boîtiers respectifs de telle sorte que les boîtiers ne font pas saillie en arrière des hauts-parleurs afin de ne pas perturber la réponse naturelle des oreilles (26) de l'auditeur.

2. Dispositif selon la revendication 1, comprenant en outre :

au moins un haut-parleur extérieur (52);  
un circuit de filtre (112) pour extraire une partie prédéterminée du spectre de fréquences d'au moins l'un des premier et second canaux du signal audio; et  
un circuit mélangeur (96) pour délivrer la partie extraite du spectre de fréquences provenant d'au moins l'un des premier et second canaux des signaux audio pour activer ledit haut-parleur (52).

3. Dispositif selon la revendication 2, dans lequel ledit circuit de filtre peut fonctionner de manière à extraire la partie prédéterminée du spectre de fréquences à partir à la fois des premier et second canaux du signal audio, et que ledit mélangeur peut fonctionner de manière à combiner la partie extraite du spectre de fréquences des premier et second ca-

naux et le signal audio en un signal monauriculaire destiné à être délivré audit haut-parleur extérieur (52).

4. Dispositif selon l'une quelconque des revendications 2 et 3, dans lequel la partie du spectre de fréquences des premier et second canaux du signal audio extrait par ledit circuit de filtre (112) comprend l'extrémité des basses fréquences du spectre de fréquences des premier et second canaux du signal audio.

5. Dispositif selon l'une quelconque des revendications précédentes, dans lequel les boîtiers desdits premier et second hauts-parleurs fixent et orientent respectivement lesdits premier et second hauts-parleurs localisés associés (60,58), de sorte qu'ils sont dirigés vers l'arrière en direction de l'un associé des pavillons de l'une associée des oreilles gauche et droite de l'auditeur et légèrement en avant de cette oreille.

6. Dispositif selon l'une quelconque des revendications précédentes, dans lequel lesdits premier et second hauts-parleurs localisés (60,58) sont supportés respectivement par lesdits premier et second boîtiers associés de hauts-parleurs, de sorte qu'ils sont disposés à proximité de l'arc zygomatique de l'auditeur sur le côté associé de la tête de ce dernier.

7. Dispositif selon l'une quelconque des revendications précédentes, dans lequel chacun des boîtiers des premier et second hauts-parleurs comprend une cavité, destinée à être disposée autour de l'oreille, desdits premier et second hauts-parleurs localisés associés pour réaliser une terminaison acoustique correcte pour lesdits premier et second hauts-parleurs associés localisés.

8. Dispositif selon l'une quelconque des revendications et comportant en outre un dispositif d'affichage (65) pour délivrer à l'auditeur, des marques visuelles qui, en liaison avec les signaux audio, améliorent l'aptitude de l'auditeur à localiser un son reproduit par lesdits premier et second hauts-parleurs localisés.

9. Dispositif selon l'une quelconque des revendications précédentes, comprenant en outre :

une source (90) de signaux audio servant à produire les premier et second canaux des signaux audio sur les première et seconde sorties (92,94); et  
une liaison de communication (184) pour le raccordement des première et seconde sorties de ladite source de signaux audio auxdits premier

et second hauts-parleurs localisés.

10. Dispositif selon la revendication 9, dans lequel ladite liaison de communication comprend une liaison de communication sans fil.

11. Procédé de production de signaux audio binauricaux contenant des premier et second canaux, comprenant les étapes consistant à :

(a) fixer un support (70) à la tête (26) d'un utilisateur en actionnant des moyens d'engagement du support de manière à engager la tête dans une disposition fixe par rapport à cette dernière et en un emplacement tel qu'il n'enserre pas les oreilles (68,66) ni ne perturbe d'une autre manière la réponse naturelle des oreilles; (b) monter des premier et second hauts-parleurs localisés (60,58) dans des boîtiers (82,80) montés de façon fixe sur les moyens d'engagement de la tête de sorte que les premier et second hauts-parleurs sont supportés dans des positions situées respectivement en avant des oreilles gauche et droite (68,66) et sont dirigés vers l'arrière en direction des oreilles gauche et droite (68,66); et (c) faire fonctionner les premier et second hauts-parleurs (60,58) pour reproduire des premier et second signaux respectivement à partir des premier et second canaux,

caractérisé par le positionnement des hauts-parleurs (60,58) de telle sorte qu'en fonctionnement les hauts-parleurs sont situés à proximité des côtés gauche et droit de la tête (26) de sorte qu'une diaphonie présente respectivement entre chacun des premier et second hauts-parleurs (60,58) et les oreilles droite et gauche (68,66) est réduite par atténuation du son par la présence de la tête; et par le support des hauts-parleurs (60,58) en arrière des boîtiers respectifs de sorte que les boîtiers (82,80) ne font pas saillie en arrière des hauts-parleurs de manière à ne pas perturber la réponse naturelle des oreilles (68,66) de l'auditeur.

12. Procédé selon la revendication 11, comprenant en outre :

l'extraction d'une partie prédéterminée du spectre de fréquences à partir d'au moins l'un des premier et second canaux du signal audio; l'utilisation d'un haut-parleur extérieur (52); et la délivrance de la partie extraite du spectre de fréquences du premier ou du second canal du signal audio au haut-parleur.

13. Procédé selon la revendication 12, selon lequel l'étape d'extraction peut être exécutée pour extraire

la partie prédéterminée du spectre de fréquences à partir des premier et second canaux du signal audio.

5 14. Procédé selon l'une quelconque des revendications 12 et 13, selon lequel la partie extraite comprend l'extrémité inférieure du spectre de fréquences, qui s'étend vers les fréquences inférieures à partir d'une valeur de fréquence prédéterminée.

10 15. Procédé selon l'une quelconque des revendications 11 à 14, selon lequel les premier et second hauts-parleurs localisés (60,58) sont disposés à proximité de l'arc zygomatique de l'auditeur.

15 16. Procédé selon l'une quelconque des revendications 11 à 15 comprenant la délivrance, à l'auditeur, de repères visuels, qui, en liaison avec le signal audio, améliorent l'aptitude de l'auditeur à intégrer les repères visuels et acoustiques.

20 17. Procédé selon l'une quelconque des revendications 11 à 16, comprenant en outre :

la production des signaux audio dans les premier et second canaux;

la transmission des signaux audio dans une liaison de communication aux premier et second hauts-parleurs localisés (60,58).

25 18. Procédé selon la revendication 17, selon lequel la liaison de communication est une liaison de communication sans fil.

30 19. Procédé selon l'une quelconque des revendications 11 à 18, selon lequel les signaux audio sont des enregistrements binauricaux.

45

50

55

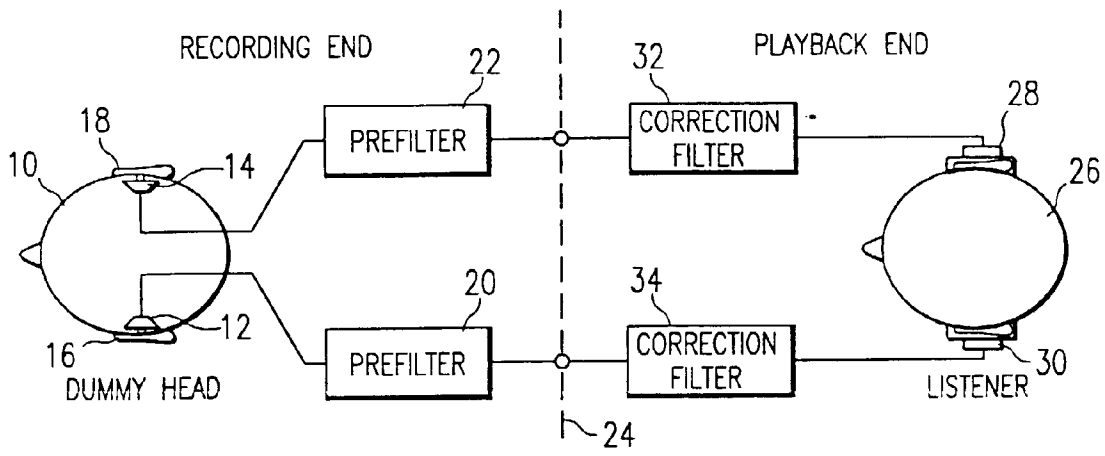

FIG. 1a (PRIOR ART)

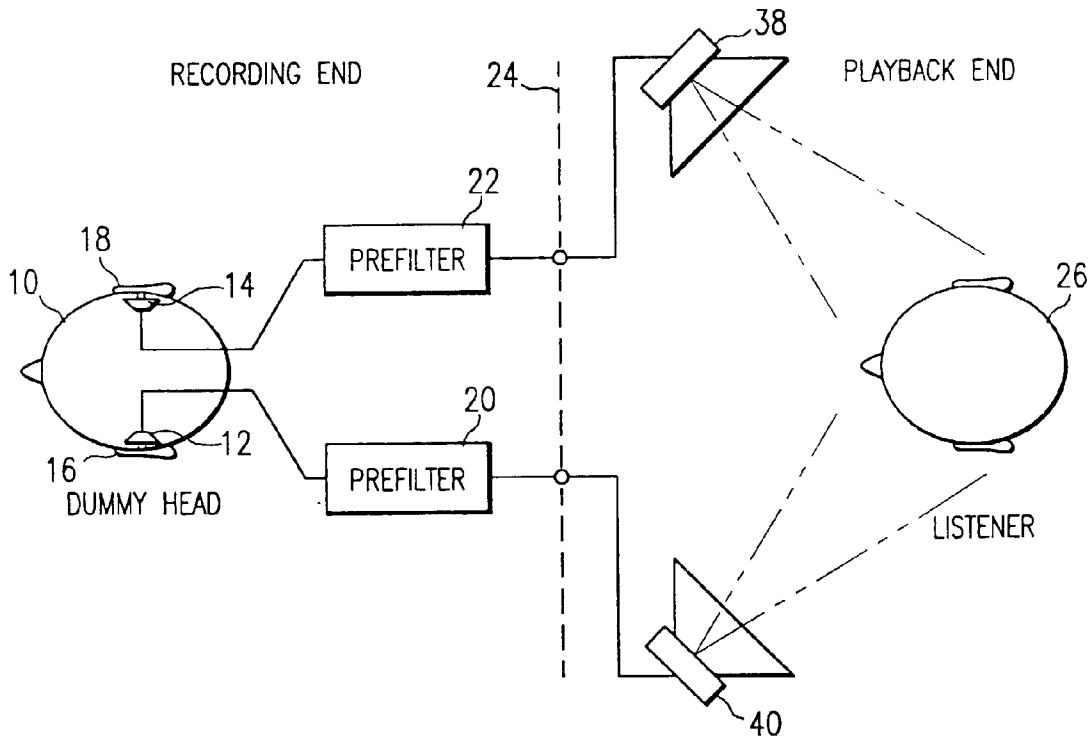

FIG. 1b (PRIOR ART)

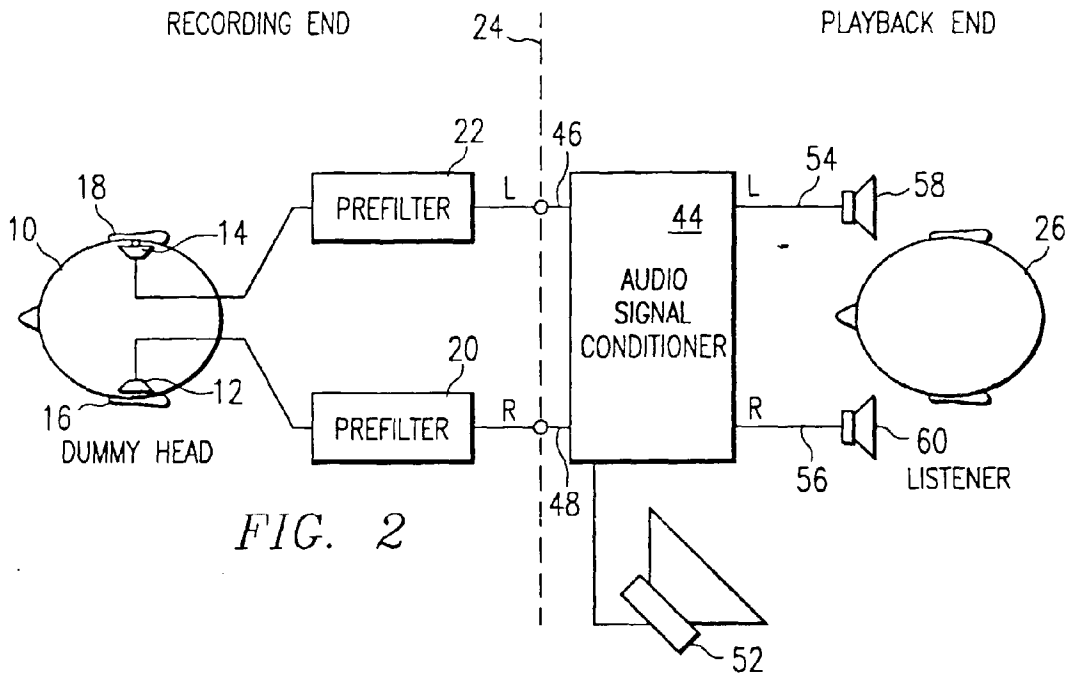

FIG. 2

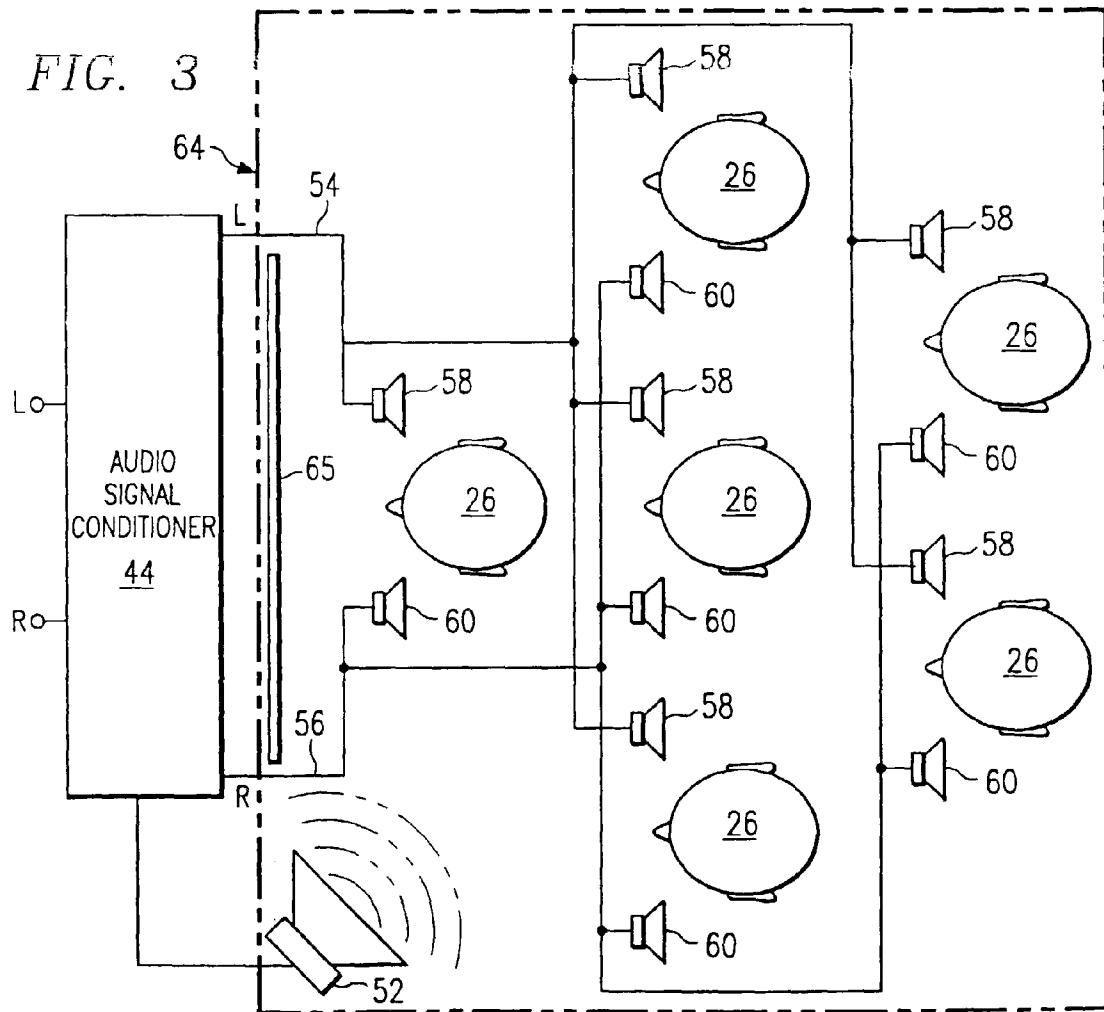

FIG. 3

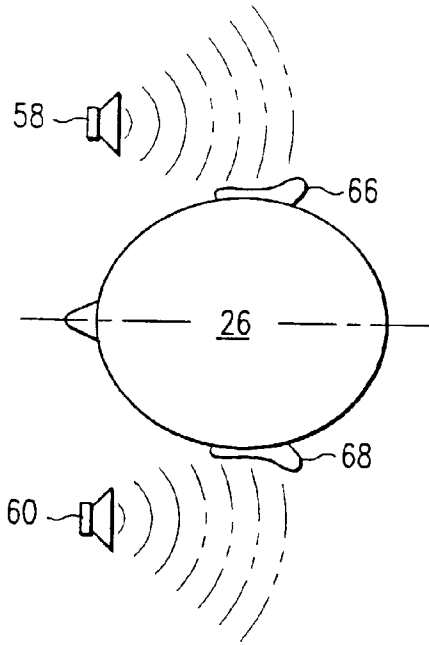

FIG. 4

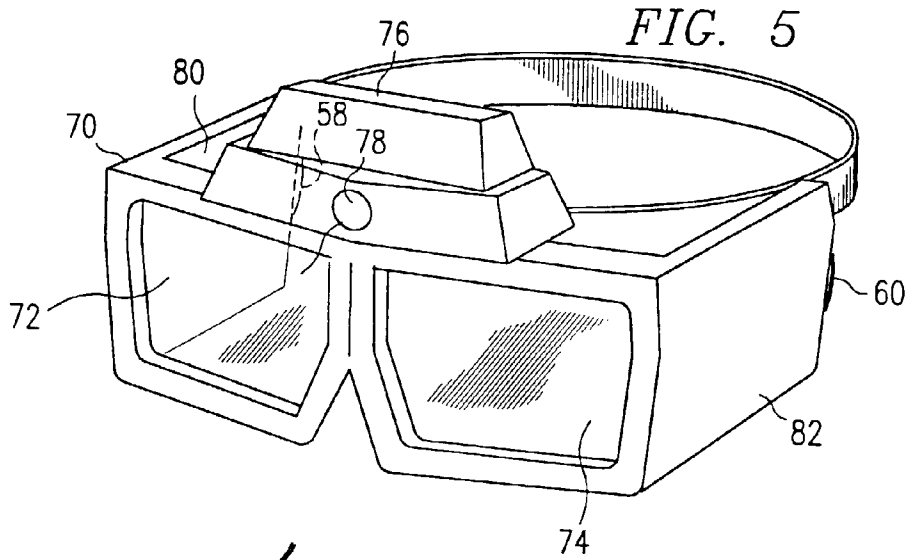

FIG. 5

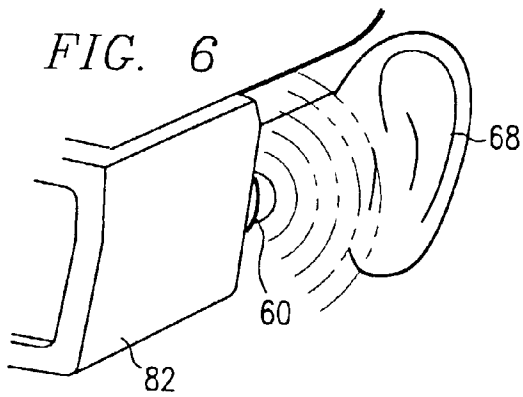

FIG. 6

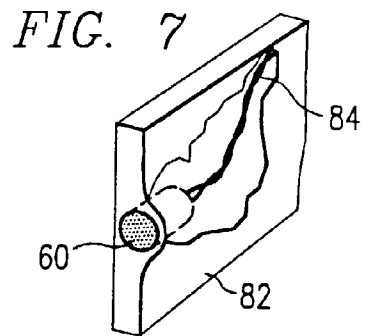

FIG. 7

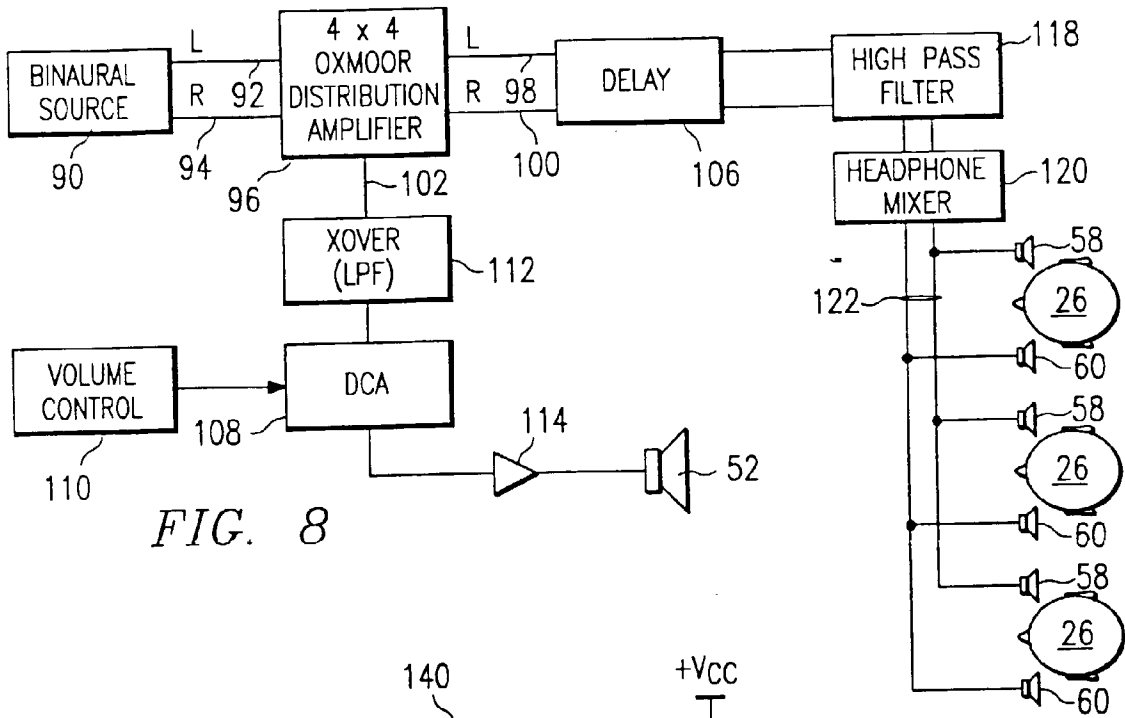

FIG. 8

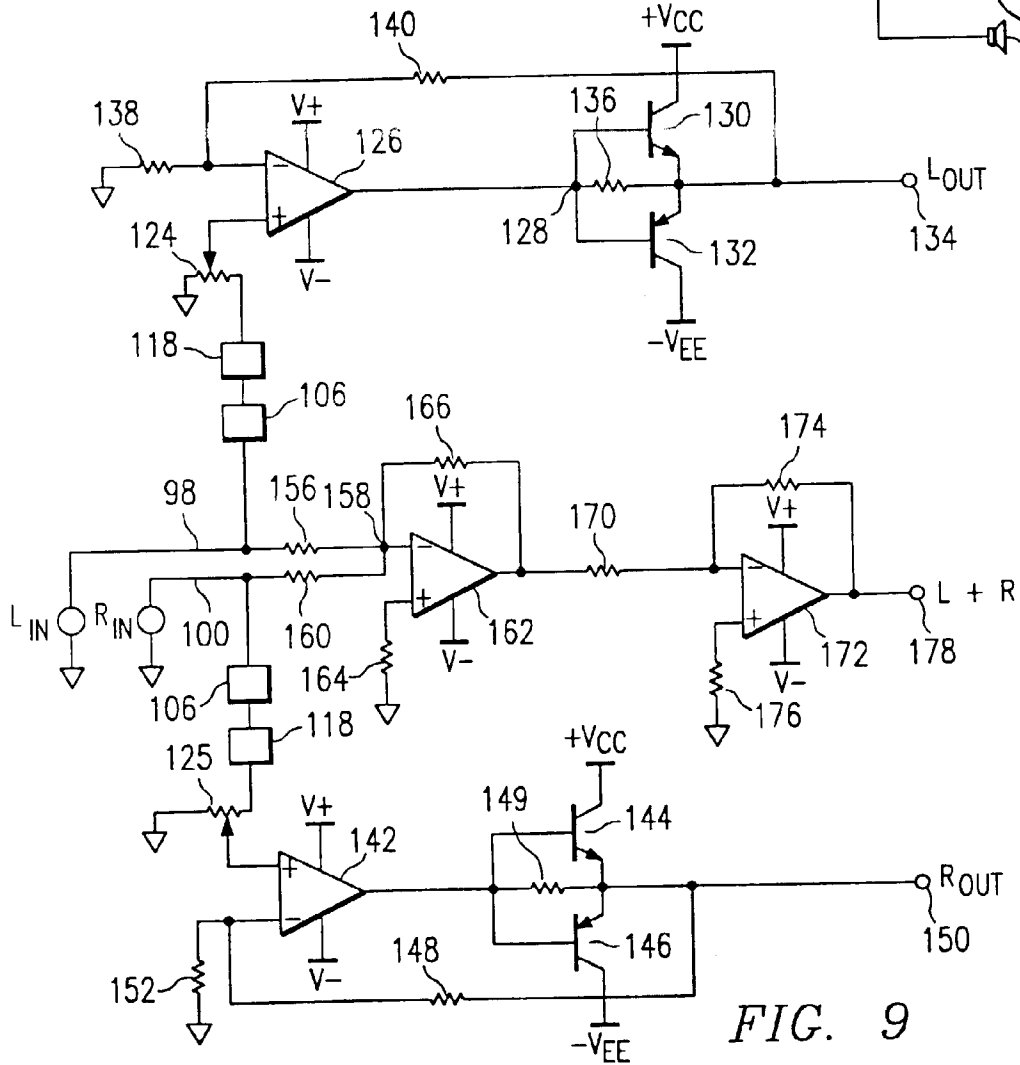

FIG. 9

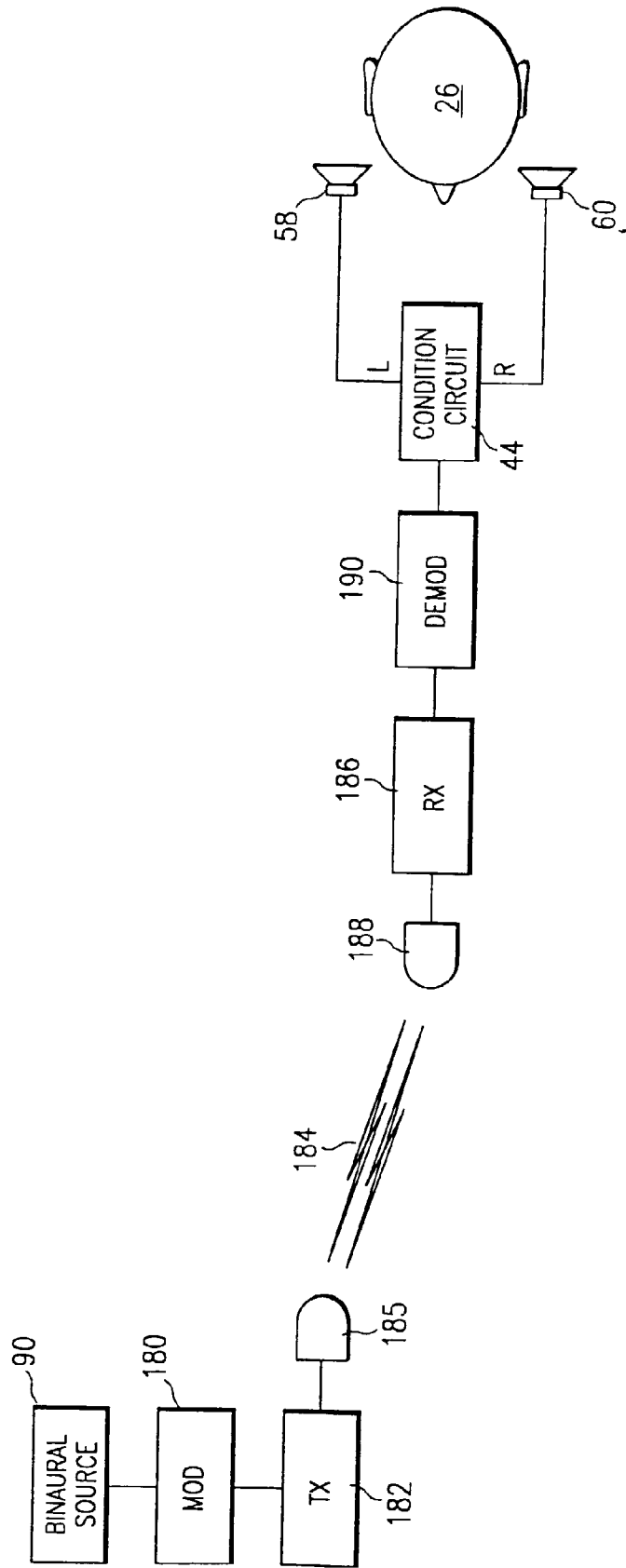

FIG. 10