

F. G. KAPELMAN.
 BED FRAME.
 APPLICATION FILED NOV. 15, 1910.

1,001,148.

Patented Aug. 22, 1911.

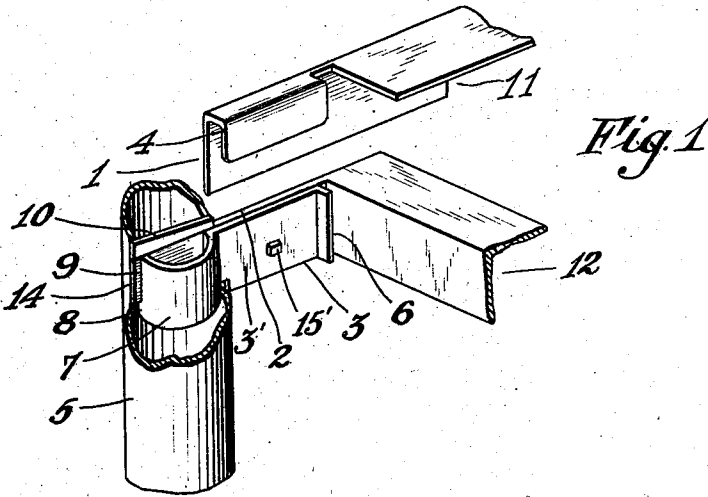

Fig. 3.

Fig. 2.

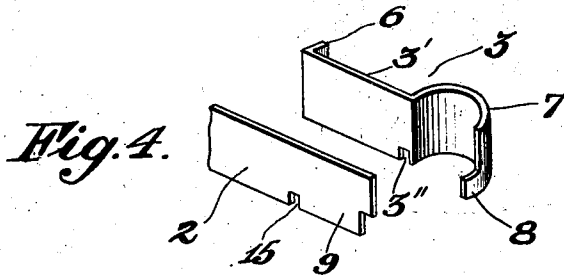
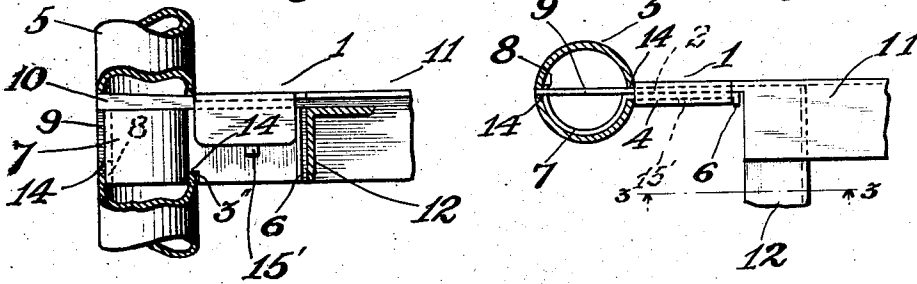

Fig. 4.

Inventor
 Felix G. Kapelman

Witnesses
 James C. Sproll.
 Ailo Jalanson.

By
 Adams & Brooks
 Attorneys

UNITED STATES PATENT OFFICE.

FELIX G. KAPELMAN, OF SEATTLE, WASHINGTON.

BED-FRAME.

1,001,148.

Specification of Letters Patent. Patented Aug. 22, 1911.

Application filed November 15, 1910. Serial No. 592,537.

To all whom it may concern:

Be it known that I, FELIX G. KAPELMAN, a citizen of the United States of America, and a resident of the city of Seattle, in the county of King and State of Washington, have invented certain new and useful Improvements in Bed-Frames, of which the following is a specification.

My invention relates to bed frames, having more particular reference to those of metallic construction, and has for its primary object the provision of a brace, of simple and durable construction by which the side and end rails are attached in an efficient manner to the corner posts.

Other objects will be set forth as my description progresses and those features of construction, arrangements and combinations of parts on which I desire protection, succinctly defined in my annexed claims.

Referring to the accompanying drawing, illustrating a preferred embodiment of my invention and in which like numerals of reference indicate like parts throughout: Figure 1 is a fragmentary perspective illustrating one corner portion of a bed frame, constructed in accordance with my invention, the brace parts being disengaged. Fig. 2 is a top plan thereof with the corner post shown in horizontal section, and the brace parts assembled. Fig. 3 is a section taken on line 3-3 of Fig. 2, and Fig. 4 is a fragmentary perspective of one brace section and the bearing member provided for the other thereof.

My brace comprises parts 1 and 2, each provided for a respective bed frame rail, as 11 and 12 of angle iron, and arranged side by side, with the latter or part 2 arranged between part 1 and a bearing member 3, which bearing member is in fixed relation to the bed post 5, of tubing, and adapted to be engaged by an angular extension 4 of part 1, such construction permitting of the brace parts being firmly held together while providing for their receiving independent and direct support from post 5.

An extremely simple and durable construction is produced by employing the end portions of the vertical flanges of rails 11 and 12 as brace parts 1 and 2. In so adapting these rails, end portions of the horizontal flange of one rail is removed, and that of the other bent to provide the downturned angular extension 4, and one of said vertical flange portions is bent at right angles to

its rail to lie parallel with the other thereof, for engagement with the angular extension 4, which, as now considered is provided on part 1.

Bearing member 3 comprises an arm 3' fixed to bed post 5, by a novel construction of fastening, and extending outwardly therefrom toward rail 12 with its outer end, on which an angular shoulder 6 is provided, disposed in proximity thereto but spaced therefrom, as shown.

In making arm 3' fast I provide an anchor 7, which is curved concentrically or substantially concentrically to the post 5, so as to conform as near as possible to the curvature of the inner face thereof and thereby be capable of having a bearing thereon substantially half the distance around the same.

At its free end portion, anchor 7 is provided with a projection or lug 8 which projects through and has bearing on the wall of a cut out formed in an extension 9, of part 2, which projects through diametrically opposite slots 14 provided in post 5 and is secured therein, as by a key 10, and adjacent the inner end portion of said anchor, arm 3' is notched, as at 3'', to fit over the bottom wall of the adjacent slot 14. Brace part 2 is notched, as at 15, for a similar purpose, which construction insures absolute rigidity between the parts.

In practice, the downturned end portion of the angular extension 4 is forced downwardly and edged between the post 5 and shoulder 6, until its movement is arrested by extreme friction between the parts, or as by a stop 15', when there will be a slight spacing between the overlapping horizontal flanges of rails 11 and 12, as clearly shown in Fig. 3, to overcome application of the weight of the overlapping rail to the lower at such point.

In my present construction bearing member 3, is formed of sheet metal so that shoulder 6 can spring out slightly under pressure exerted in seating extension 4, as just described, thereby maintaining the latter under such tension as to securely hold the same while permitting of its comparatively ready disengagement.

In assembling the device, anchor 7 is first positioned in the post by turning the same slightly during its insertion through the relatively wide slot 14 (see Fig. 2) at the inner side of the post. Extension 2 is then

properly positioned, after which key 10 is driven, as hereinbefore described. Rail 11 is now secured to post 5 in angular relation to rail 12 by forcing the same downwardly with extension 4 of its brace part engaged between said post and shoulder 6.

Having thus described my invention, what I claim as new, and desire to secure by Letters Patent of the United States of America, is:

1. In combination with a corner post, an end rail, and a side rail, a brace comprising opposing parts each fixed to a respective rail of said bed frame, one of said brace parts projecting horizontally from its rail and at right angles thereto, and a connecting angular extension on the other of said brace parts engaged over the upper edge of said first named brace part and having its free end portion received between said post and said last named rail.

2. In combination with a corner post, an end rail, and a side rail of the bed frame, a brace comprising opposing parts each fixed to a respective rail of said bed frame, means securing one of said brace parts directly to said post, a relatively fixed bearing on said post projecting outwardly therefrom and a connecting angular extension on the other of said brace parts extending over the upper edge of said first named brace part and having its down-turned free end portion engaged with said bearing to be supported thereby.

3. In combination with a corner post, an end rail, and a side rail of the bed frame, a brace comprising opposing parts each fixed to a respective rail of said bed frame, means securing one of said brace parts to said post, a relatively fixed bearing on said post projecting outwardly therefrom to provide an independent support for the other of said brace parts, and means on the other of said brace parts seated on said bearing to thereby support said last named brace part and connect the latter to said first named brace part.

4. In combination with a corner post, an end rail, and a side rail of the bed frame, a brace comprising opposing parts each fixed to a respective rail of said bed frame, means securing one of said brace parts to said post, a bearing fixed to said post and extending outwardly alongside said last named brace part and provided with a shoulder, and an angular extension on the other of said brace parts having a downturned portion engaged with the shoulder of said bearing and said post.

5. In combination with a corner post, an end rail, and a side rail, a brace comprising opposing parts each fixed to a respective rail of said bed frame, one of said brace parts extending at an angle to its rail, a fixed bearing on said post extending out-

wardly alongside one part of said brace, and connecting means on the other component part of said brace extending across into engagement with said bearing, to receive support therefrom.

6. In combination with a hollow corner post, an end rail, and a side rail, a brace comprising opposing parts each fixed to a respective rail of said bed frame, one of said brace parts having an extension projecting into said post, a bearing member having an anchoring part arranged in said post, means whereby the extension of said brace part and said anchoring part of said bearing member are held in relatively fixed relation to said post, and means on the other of said brace parts engaged with said bearing to receive support therefrom.

7. In combination with a hollow corner post formed with diametrically opposite slots, a member projecting through the slots of said post, a brace part fixed to said member, a second brace part releasably connected with said first brace part, and a support for holding said second brace part against downward movement having an anchoring portion arranged in said post, said anchoring portion being curved to have bearing on the inner face of said post and being provided with an extension engaged with said member to form a connection therewith.

8. In combination with a hollow corner post formed with diametrically opposite slots, and side and end rails of the bed frame, a member projecting through the slots of said post, two brace parts each fixed to a respective bed frame rail and one extending at an angle to its rail, an angular extension on the other brace part extending over the first named brace part and having its free portion directed downwardly, a bearing projecting outwardly from said post to be engaged by the free portion of said angular extension and thereby forming a support for the frame rail on which the brace part is provided, the outer end of said bearing being spaced from the adjacent bed frame rail, and an anchoring member for said bearing projecting into said post and connected with said first member.

9. In combination with a corner post, and side and end rails of the bed frame, a brace comprising opposing parts each connected with a respective bed frame rail, means securing one of said frame parts to said post, a bearing projecting outwardly from said post and being spaced from the adjacent rail of said bed frame, and an angular extension on the other of said brace parts engaged with said bearing and held thereby in rigid relation to said post.

10. In combination with a corner post formed with an opening, an end rail, and a side rail, a brace comprising opposing parts

each fixed to a respective rail of said bed
frame, one of said brace parts projecting
horizontally from its rail and at right an-
gles thereto and having its free end portion
5 projecting through the opening of said post,
means securing the last named portion of
said angularly projecting brace section in
said post, and a connecting angular exten-
sion on the other of said brace parts en-
10 gaged over the upper edge of said first

named brace part and having its free end
portion received between said post and the
rail of said first named brace section.

Signed at Seattle, Washington, this 5 day
of November 1910.

FELIX G. KAPELMAN.

Witnesses:

ARLITA ADAMS,
ERNESTINE DESILETS.