

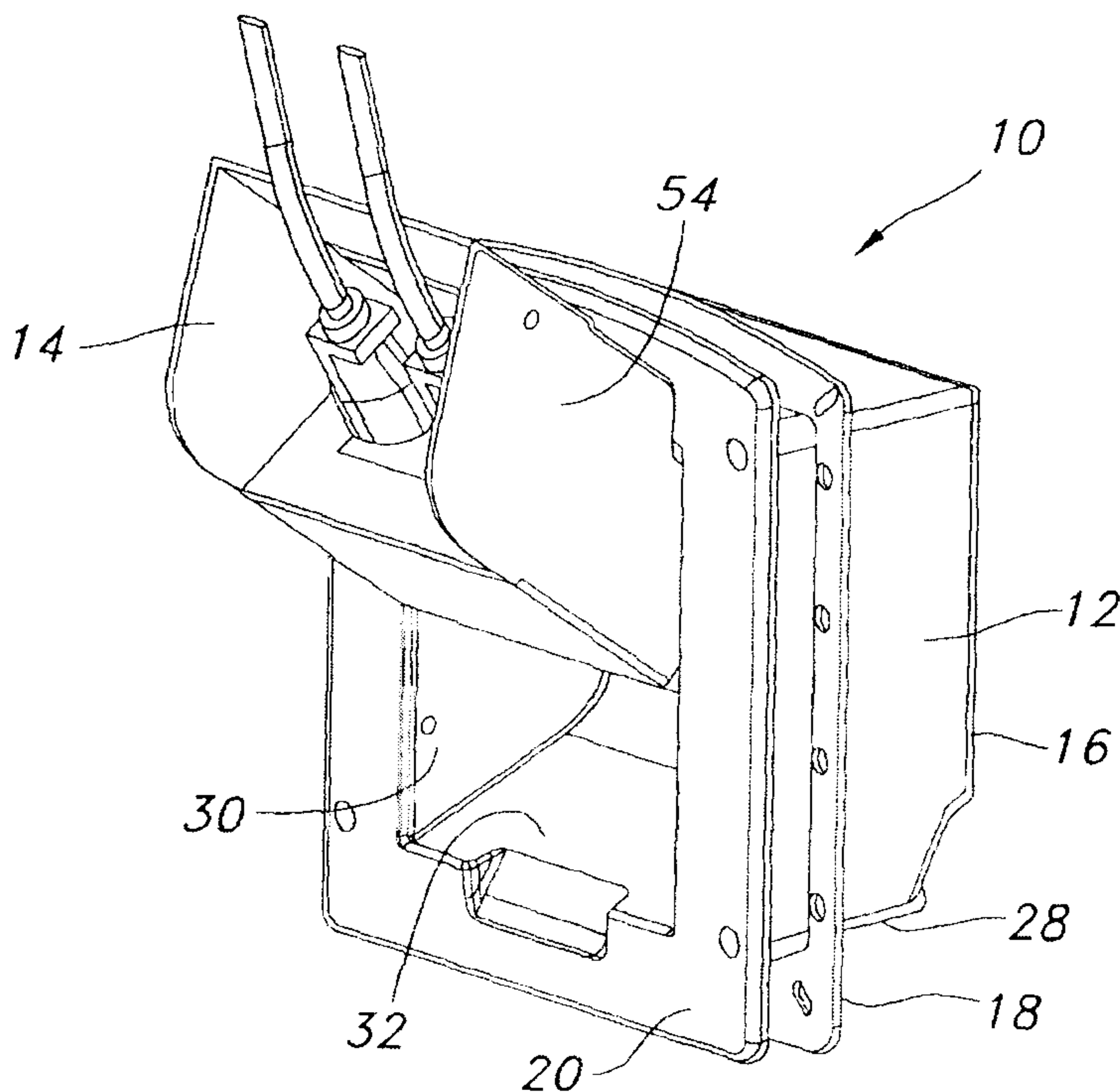

(22) Date de dépôt/Filing Date: 2009/12/07
 (41) Mise à la disp. pub./Open to Public Insp.: 2010/06/11
 (45) Date de délivrance/Issue Date: 2012/05/08
 (30) Priorité/Priority: 2008/12/11 (US61/121,710)

(51) Cl.Int./Int.Cl. *H02G 3/08* (2006.01),
H02G 3/14 (2006.01)
 (72) Inventeurs/Inventors:
 DRANE, MARK R., US;
 DINH, CONG T., US;
 MAGNO, JOEY D., JR., US;
 JOLLY, ROBERT KEVIN, US
 (73) Propriétaire/Owner:
 THOMAS & BETTS INTERNATIONAL, INC., US
 (74) Agent: MACRAE & CO.

(54) Titre : COFFRET DE BRANCHEMENT ET COUVERCLE PIVOTANT EN SERVICE
 (54) Title: PIVOTING WHILE-IN-USE ELECTRICAL BOX AND COVER



(57) Abrégé/Abstract:

The present invention is directed to a "while-in-use" electrical box device including an electrical box housing and pivotable cover which function as an integral unit and rotate on a fixed frame.

ABSTRACT OF THE INVENTION:

[0033] The present invention is directed to a “while-in-use” electrical box device including an electrical box housing and pivotable cover which function as an integral unit and rotate on a fixed frame.

PIVOTING WHILE-IN-USE ELECTRICAL BOX AND COVER

[0001]

FIELD OF THE INVENTION:

[0002] The present invention relates generally to a box for housing electrical termination devices such as jacks and receptacles. More particularly, the present invention relates to an electrical box with a pivotable cover member.

BACKGROUND OF THE INVENTION:

[0003] Electrical boxes and housings are typically used to house electrical termination devices such as electrical receptacles and data/communication jacks which terminate wires running thereinto. These termination devices are provided so as to permit connection of electrical wires and cables terminated by complimentary termination devices such as plugs and the like.

[0004] With many electrical boxes, especially those which are used to house termination devices positioned within a floor or wall, it is desirable to construct the box to provide easy access for inserting the plug yet is not interfering.

[0005] A typical exterior electrical box has a cover which is pivoted to an open position to reveal the various power and signal components which are terminated therein. If covered, the

user must open the cover, pull the plug into the box, locate the receptacle, and properly align and connect the plug to the receptacle in the confined space of the box. All this occurs with minimal viewing ability to assist in confirming the connection without damage or injury. Conventional covers open perpendicularly, approximately 90° from the horizontal disposition of the wall-mounted receptacles. This limitation on cover travel results from ease of manufacture, spring tension, weather protection and/or because the cover of a recessed box abuts the housing frame.

[0006] It is, therefore, desirable to provide an electrical box assembly which provides a cover opening to an obtuse angle, allowing for easy access and viewability of the receptacle and connections therein, while still affording protection from precipitation when the cover is open.

SUMMARY OF THE INVENTION:

[0007] The present invention is directed to a “while-in-use” electrical box device with a pivotably opening cover formed with an asymmetric channel proximally disposed to the axis. A pair of flanged pins is affixed to the cover at opposite sides of the axis to pivot in weatherproof receiving sockets. This channel or indent is angled so as to permit the cover to receive the trim or locking frame portion of the electrical box, thereby opening upward to an obtuse angle relative to the position of the cover when closed. This configuration enhances visibility and accessibility to the power receptacles housed within the electrical box, particularly when configured with the receptacles fixed to the box housing, with only the cover pivotably opening. The cover depends perpendicularly from the plane of the receptacle in the closed position with an embrasure in the housing communicating with an embrasure in the locking frame to provide clearance for cords to extend downward from the receptacles. Detents in the cover and housing assist retaining the

cover in the open or closed positions. An angular removable back wall with knockout ports facilitates connection from the source power supply and forms an area for cords to bend. A rear frame holds the assembly together in a flush mounting arrangement.

[0008] In the preferred embodiment receptacles are affixed to the inside front cover of the box instead of inside the box housing, thereby pivoting with the cover to the open position to face upwards for ease of use. At least one flanged pin includes an annular opening therethrough communicating with the interior of the cover. This opening acts as a bushing through which wires may pass through the cover wall without abrasion to energize the receptacles. An electric terminal mounted to the housing wall provides strain relief to the power supply wires. The depending cover extends outward in the open position such that it extends sufficiently when open to shield the upward facing receptacles from precipitation.

[0009] Additionally, the present invention provides an electrical box assembly including a box having an upper wall, interior side walls, exterior side walls, interior back wall, exterior lower wall, an exterior back wall and an open front face. The interior side walls and the exterior side walls are spaced apart and extend from the upper wall. The interior back wall extends from the upper wall. Also, the interior back wall extends between the interior side walls. The exterior back wall extends between the exterior side walls. Further, the exterior back wall extends between the upper wall and the exterior lower wall. The open front face is defined by the interior side walls, the interior back wall and the upper wall. The open front face has a perpendicular flange extending about a perimeter of the open front face. The box has an interior cavity defined by the interior side walls, the interior back wall, the upper wall and the open front

face. The assembly further includes a cover pivotally attached to the box. The cover has an open position and a closed position. The cover seats within the interior cavity when the cover is in the closed position. The cover includes a pair of cover side walls, cover back wall, cover top wall and cover front wall. The cover front wall includes a concaved channel therein. The concaved channel provides an cavity for receiving the flange of the box when the cover is in the open position.

[0009.1] In accordance with one aspect of the present invention, there is provided an electrical box assembly comprising: (a) a box having side walls and an open front face defined by the side walls, the open front face having a perpendicular flange extending about a perimeter of the open front face, the box having an interior cavity defined by the side walls and the open front face; and (b) a rectangular cover pivotally attached to the box, the cover having an open position and a closed position, the cover seats within the interior cavity when the cover is in the closed position, the cover includes a pair of cover side walls, cover back wall, cover top wall and cover front wall, the cover front wall includes a concaved channel therein, the concaved channel provides an cavity for receiving the flange of the box when the cover is in the open position.

BRIEF DESCRIPTION OF THE DRAWINGS

[0010] Figure 1 is an isometric showing of the electrical box assembly of the embodiment with the receptacle pivoting with the cover in the open position.

[0011] Figure 2 is a an exploded view of the electrical box assembly of Figure 1 showing the pivoting cover in the fully open position with power cords connected to the receptacle disposed within the cover.

[0012] Figure 3 is a side sectional view of the electrical box assembly of Figure 1 showing the cover in the closed position with a power cord engaged with the receptacle.

[0013] Figure 4 is a side sectional view of the electrical box assembly of Figure 1 showing the cover in the open position with a power cord engaged with the receptacle.

[0014] Figure 5 is a rear perspective view of the interior of the box housing of the box assembly Figure 1.

[0015] Figure 6 is a front perspective view of the electrical box assembly of Figure 1 with the cover in the closed position.

[0016] Figure 7 is a perspective view of the electrical box assembly of Figure 1 in phantom showing the electrical connections therein.

[0017] Figure 8 is a partial perspective view of the electrical box assembly of Figure 1 showing a portion of the box housing in phantom to show the electrical wiring within the cam.

[0018] Figure 9 is a side perspective view of the electrical box assembly of Figure 1 with the cover in the open position.

DETAILED DESCRIPTION OF THE PREFERRED EMBODIMENT

[0019] Figures 1-9 show the present invention is directed to an outdoor electrical box assembly including an electrical box housing and a cover which function as an integral unit and rotate in a fixed frame. The box assembly is recessed into a wall. The cover includes a recess to allow upward rotation of the cover a minimum of about 125 degrees. Rotating the integral box and cover upwardly allows user to easily see the electrical device when inserting a power plug. Once the plug is inserted the integral box and cover are rotated down vertically and snapped closed.

[0020] Referring now to Figures 1-3, the electrical box assembly **10** of the present invention is shown. Box assembly **10** includes an electrical box housing **12**, a pivoting cover **14** a removable back wall **16**, a back frame **18** and a locking frame **20**.

[0021] Box housing **12** is generally square with a double wall construction to provide an interior cavity for cover **14** to seat and an exterior cavity between the double walls to provide a cavity for the electrical and terminal equipment to seat. The box housing **12** includes an upper wall **26** attached to exterior walls and interior walls. The exterior walls include exterior side wall **22** and exterior lower wall **28**. The interior walls include interior side walls **30** and interior back wall **32**. The pair of exterior side walls **22** is rectangular with a back corner of the rectangle cut-off. One edge of the exterior side walls **22** is attached to a substantially planar inner flange **24** which extends perpendicular from the exterior side walls **22**. The pair of exterior side walls **22** is attached to an upper side wall **26**. The upper wall **26** is generally rectangular in shape and has four edges. Each edge is attached perpendicularly to extending members, such as exterior side walls **22**, flange **24** or back wall **16**. The attachment point between the exterior side walls **22** and the upper wall **26** includes channels with holes to provide for attachment of the removable back wall **16** to the remaining box housing **12**. Exterior lower wall **28** is generally rectangular and is attached on two opposing edges by the exterior side walls **22**. At the joint where the exterior lower wall **28** edge and each exterior side wall **22** edge meets is a channel including a hole which provides a means of attaching the removable back wall **16** to the remaining box housing **12**. The exterior lower wall **28** is also attached to the flange **24** which extends perpendicular to the exterior lower wall **28**. In this embodiment, the exterior lower wall **28** is shorter than the upper wall **26** which accommodates the geometry of the back wall **16**.

[0022] Figures 2, 3 and 4 show box housing **12** having an interior box housing **34**. Interior box housing **34** is defined by a pair of interior side walls **30**, an interior back wall **32** and the upper wall **26**. One edge of each interior side wall **30** and one edge of interior back wall **32** is attached to upper wall **26** on the lower surface. Interior box is generally a rectangular box like member with a curved back wall **32** which is continuous to form both the back wall and the bottom wall of the interior box **34**. The interior side walls **30** include cam receiving openings **37**, **39** to provide for pivotable attachment of the cover and an opening for electrical wires to extend therethrough into the cam **14**. Interior side wall **30** also includes aperture **31** for cooperatively engaging with cam protrusions and assist in securing the cover in the closed position. The interior side walls **30** are set a distance in from the exterior side walls **22** to provide a back cavity **44** therebetween for terminals and electrical wires to be placed therein.

[0023] Figure 2 shows flange **24** extending about open front **36** of internal cavity **34**. Flange **24** extends perpendicularly from side walls **32**, **22**, lower wall **28** and upper wall **26**. Flange **24** is substantially planar with two opposing cam receiving slots **38**, **40** for attachment of the cover **14**, access to electrical wires and terminals. Flange **14** also includes divot **42** for the wires of a plug to extend therethrough when the cover **14** is in the closed position, see Figure 3.

[0024] Figures 2, 3 and 4 show removable back wall **16** which attaches to the back of the box housing **12** to enclose the back cavity **44**. The back wall **16** includes a rectangular portion **46** and a lower lip or ridge portion **48** extending perpendicular to the rectangular portion **46**. Lower ridge portion **48** is attached to angular planar portion **50**. The rectangular portion **46**

includes an inset rim **52** which is U-shaped and protrudes perpendicularly outward from the back wall **16**. The rim **52** assists with proper positioning and securement of the back wall **16** to the box housing **12**. The rectangular portion **46** includes holes which align with the holes of the box housing **12** to provide securement of the back wall **16** to the exterior side walls **22** with fasteners. Angular portion **50** includes knock-outs for power supply lines to extend from the floor or wall into the box assembly **10**.

[0025] Referring to Figures 1-4, pivoting cover **14** has generally rectangular shaped geometry designed to seat inside box interior **34**. Cover **14** includes a pair of cover side walls **54**, a cover back wall **56**, a cover top wall **58** and a cover front wall **60**. Cover back wall **56**, opposed cover front wall **60** is generally rectangular extending from cover top wall **58** and between cover side walls **54**. Cover back wall **56** is shorter in length than cover front wall **60**. Cover top wall **58** is generally rectangular and extends between cover side walls **54**, and between cover back wall **56** and cover front wall **60**. Figures 2-4 and 6 show the cover front wall **60**. Cover front wall **60** includes a rectangular planar portion **62**, a concaved channel **64**, and a semi-cylindrical portion **66**. The semi-cylindrical portion **66** extends from the top wall **58** in an arc shape forming a half cylindrical across the top of the front cover **60**. The semi-cylindrical portion **66** extends between the top wall **58** and the concaved channel **64**. The concaved channel **64** is defined by the semi-cylindrical portion **66** and an angled slope **68**. The channel **64** extends the width of the cover front wall **60**. The channel **64** is concaved having an angle **A** of less than 90° with respect to the rectangular portion **62** and the semi-cylindrical portion **66**. Figure 4 shows Angle **A** and the semi-cylindrical portion **66** provides clearance for the cover **14** with respect to the locking flange **20** and box flange **24** when the cover **14** is in the opened position.

The angled slope **68** of the concaved channel **64** is attached to the cover rectangular portion **62**. The angled slope **68** extends from the cover rectangular portion **62** towards the cover back wall **56** at an angle **B** which is an obtuse angle. The cover rectangular portion **62** extends from the angled slope **68** of the unattached end **70** of the cover **14**, as shown in Figure 6. Angle **B** can be increased and angle **A** can be increased such that the angled slope **68** extends towards the end of the cover at less of an incline which allows for the cover **14** to open wider, at an increasing angle **C**.

[0026] Figure 2 shows cover side walls **54** which extends between the cover front wall **60** and the cover back wall **56**, and the cover top wall **58** and the unattached end **70** of the cover **14**. The cover side walls **54** include a concaved divot **72** which corresponds to the cross sectional geometry of the channel of the cover front wall **60**. The cover side wall **54** includes a rounded corner portion **74** which corresponds with the geometry of the semi-cylindrical portion **66** front wall cover **60**. The rounded corner **74** encircles or surrounds cam **76**, such that cam **76** is positioned on the surface of the cover side wall **54** a distance from the edges of the cover side wall **54**. Cam **76** is generally a hollow cylindrical shape protruding perpendicular from the cover side wall **54**. The cam **76** includes a flange **78** which protrudes outwardly about the end of the cam **76** and the flange **78** is parallel with the cover side wall **54**. The cam **76** includes hole **80** therethrough for electrical wires to extend therethrough for access to the receptacle attached inside of the cover **14**. Cover side wall **22** includes an angled curved corner **82** diagonal the rounded cover **74**. The curved corner **82** is designed to fit within the inner cavity **34** of the box housing **12** and conform with the interior back wall **32**. The surface of the cover side walls **54** is generally planar except for the cam **76** and a pair of protrusions **84**. Protrusions **84** engage with

holes 31 of the interior side walls 30 to hold the cover 54 in a closed position. The cover 14 includes a cover cavity 86 which is defined by the cover side walls 54, cover back wall 56, cover top wall 58, cover front wall 60. The cover cavity 86 provides for attachment of a receptacle 88 therein. The cover cavity 86 provides open space for the plugs to connect to the receptacle and extend within the cover cavity 86. Receptacle 88 is attached at an angle within the cover cavity 86 to allow for easy access to the connections of the receptacle 88. Figures 3 and 4 show the receptacle 88 extends from the end of the cover back wall 56 to the end of the angles slope 68.

[0027] Box assembly 10 is assembled by attaching the back wall 16 to the box housing 12 using fasteners which secure the back wall 16 by extending through the various holes. A back frame 18 is slid over the exterior surface of the box housing 12 so as to encompass the box housing 12 therein. The back frame 18 abuts the flange 24 of the box housing 24 and secured thereto, as shown in Figure 3. The back frame 18 is a generally rectangular frame with a rectangular opening 96 in the center. Back frame 18 includes a perpendicularly extending rib 98 which frames the circumference of the back frame opening 96. The rectangular opening 96 is about the size of the cross-section of the exterior dimension of the box housing 12, such that the frame 18 slides over the box housing 12 and the back frame rib 98 is in contact with the box housing 12 exterior surface.

[0028] The back frame 18 includes an aperture 100 with raised extensions 102 about the aperture 100. The back frame 18 is attached to the box housing 12 using fasteners which extend through apertures 100 and extensions 102 into holes in the frame 24 of the box housing 12. The raised extensions 102 are approximately the same width as the back frame rib 98. The raised

extensions **102** provide spacing between the frame **24** and back frame **18** from a support structure such as a wall, sheet rock, flooring to extend therebetween. The box assembly is recessed into a wall and the back frame secures the box to the wall.

[0029] The cover **14** is attached to the box housing **12** by use of cams **76** and cam receiving slots **37, 39**. The cams **76** of the cover **14** are placed into the cam receiving slots **37, 39**. Then a gasket **90** is placed over cam receiving slot opening **40**. Locking flange **20** is placed over cover flange **24** and fasteners are used to secure locking flange **20** to flange **24**. Locking flange **20** covers the cam receiving slot **37, 39** and gasket **90** to prevent cams **76** from exiting the slot openings **38, 40**. Locking flange **20** is a rectangular strip of planar material which covers the entire inner flange **24**. Locking flange **20** includes two inner extending semi-circular prongs **92** for aligning and engaging with the cylindrical portion of cam **76** to secure cover **14** in place. Locking flange **20** is removable and can be replaced if the user wants a different color, texture or material. Additionally, a gasket (not shown) may be placed between flange **24** and locking flange **20**. Locking flange **20** includes cut-out **94** which correspond with divot **42** of the inner flange **24** to allow for egress of wires when the cover **14** is in the closed position, as shown in Figure 3.

[0030] Prior to securing the back wall **16** to the box housing **12**, the electrical wires, switches, terminals and necessary electrical input equipment is placed within the back cavity **44** of the box housing **12**. Figures 7 and 8 show the input wires **104** entering the cavity **44** and connecting to terminal **106**. The wires enter inside the moving cover through the receiving cam

opening 39 of the box housing 12 and through hole 80 of cams 76 to the receptacle mounted in the cover 14.

[0031] Figures 1, 2, 4 and 6 show the box assembly 10 completely assembled. Figures 4 and 9 show the cover 14 in an opened position. The channel 64 of the cover 14 allows for the cover 14 to open at an obtuse angle C. Angle C opens up to at least about 125°. Figure 4 shows the channel 64 accommodating for the locking frame 20 and allowing the locking frame 20 to protrude into the cavity of the channel 64. As the cover 14 rotates upwardly increasing the angle C, the semi-cylindrical portion 66 rotates about the axis of the cover 78. The semi-cylindrical portion 66 surrounds the cover 78 and the semi-cylindrical portion 66 enters the interior cavity 34 of the box 12. The cover 14 is fully opened when angle C is at its maximum angle, locking flange 20 enters the cavity of channel 64, angled slope 68 of the cover 14 is in contact with the locking flange 20 and the entire semi-cylindrical portion 66 is within the interior cavity 34 of the box housing 12. Additionally, as the cover 14 is opened, the cover back wall 56 exits the interior cavity 32 of the box housing 12. This rotation of the cover 14 and repositioning of the cover 14 allows for maximum opening and access to the receptacle therein. Additionally, this allows for a flush mount box assembly with maximum opening angle C.

[0032] It will be appreciated that the present invention has been described herein with reference to certain preferred or exemplary embodiments. The preferred or exemplary embodiments described herein may be modified, changed, added to or deviated from without departing from the intent, spirit and scope of the present invention. It is intended that all such

additions, modifications, amendments and/or deviations be included within the scope of the invention.

WHAT IS CLAIMED IS:

1. An electrical box assembly comprising:
 - (a) a box having side walls and an open front face defined by said side walls, said open front face having a perpendicular flange extending about a perimeter of said open front face, said box having an interior cavity defined by said side walls and said open front face; and
 - (b) a rectangular cover pivotally attached to said box, said cover having an open position and a closed position, said cover seats within said interior cavity when said cover is in said closed position, said cover includes a pair of cover side walls, cover back wall, cover top wall and cover front wall, said cover front wall includes a concaved channel therein, said concaved channel provides an cavity for receiving said flange of said box when said cover is in said open position.
2. The electrical box assembly of claim 1 wherein said cover opening at an angle of at least 125 degrees with respect to the closed position.
3. The electrical box assembly of claim 1 wherein said cover back wall is shorter than said cover front wall.
4. The electrical box assembly of claim 1 further including a receptacle attached to said cover.

5. The electrical box assembly of claim 1 wherein said cover front wall includes a planar rectangular portion, an angled slope portion attached to said rectangular portion and a semi-cylindrical portion.
6. The electrical box assembly of claim 5 wherein said concaved channel is defined by said semi-cylindrical portion and an angled slope.
7. The electrical box assembly of claim 6 wherein said concaved channel having an angle of less than about 90 degrees.
8. The electrical box assembly of claim 1 wherein each of said pair of cover side walls includes a cam and said side walls of said box include cam receiving slots for accepting said cam therein.
9. The electrical box assembly of claim 1 wherein said pair of cover side walls include protrusions and said box walls include holes for accepting said protrusions therein to secure said cover within said box when said cover is in the closed position.
10. The electrical box assembly of claim 1 further including a locking frame, said locking frame is attached to said flange of said box to secure said cover to said box.
11. The electrical box assembly of claim 1 wherein said side walls are interior side walls which extend from an upper wall to an interior back wall.

12. The electrical box assembly of claim 11 further including a pair of exterior side walls extending from said upper wall to an exterior lower wall, wherein said pair of exterior side walls are spaced apart from said interior side walls.

13. The electrical box assembly of claim 12 further including a back wall attached to said exterior side walls and extending from said upper wall to said lower wall, wherein said back wall is spaced apart from said interior back wall.

14. The electrical box assembly of claim 13 further including a locking frame, said locking frame is attached to said flange of said box to secure said cover to said box; and a back frame, said back frame is attached to said flange wherein said flange is sandwiched between said back frame and said locking frame.

15. The electrical box assembly of claim 13 further including a back cavity defined by said interior back wall, said exterior back wall, said upper wall, said interior side walls and said exterior side walls.

16. The electrical box assembly of claim 11 wherein said interior back wall is curved extending from said upper wall to said open front face.

17. The electrical box assembly of claim 16 wherein said pair of cover side walls includes an angled curved corner which conforms with the curved interior back wall to allow said cover to seat within said interior cavity.

18. An electrical box assembly comprising:

(a) a box having an upper wall, interior side walls, exterior side walls, interior back wall, exterior lower wall, an exterior back wall and an open front face, said interior side walls and said exterior side walls are spaced apart and extend from said upper wall, said interior back wall extends from said upper wall, said interior back wall extends between said interior side walls, said exterior back wall extends between said exterior side walls, said exterior back wall extends between said upper wall and said exterior lower wall; said open front face is defined by said interior side walls, said interior back wall and said upper wall, said open front face having a perpendicular flange extending about a perimeter of said open front face, said box having an interior cavity defined by said interior side walls, said interior back wall, said upper wall and said open front face; and

(b) a rectangular cover pivotally attached to said box, said cover having an open position and a closed position, said cover seats within said interior cavity when said cover is in said closed position, said cover includes a pair of cover side walls, cover back wall, cover top wall and cover front wall, said cover front wall includes a concaved channel therein, said concaved channel provides an cavity for receiving said flange of said box when said cover is in said open position.

19. The electrical box assembly of claim 18 further including a locking frame, said locking frame is attached to said flange of said box to secure said cover to said box; and a back frame, said back frame is attached to said flange wherein said flange is sandwiched between said back frame and said locking frame.

20. The electrical box assembly of claim 19 wherein said pair of cover side walls includes an angled curved corner, said interior back wall is curved to conform with said cover side walls allowing said cover to seat within said interior cavity.

1/8

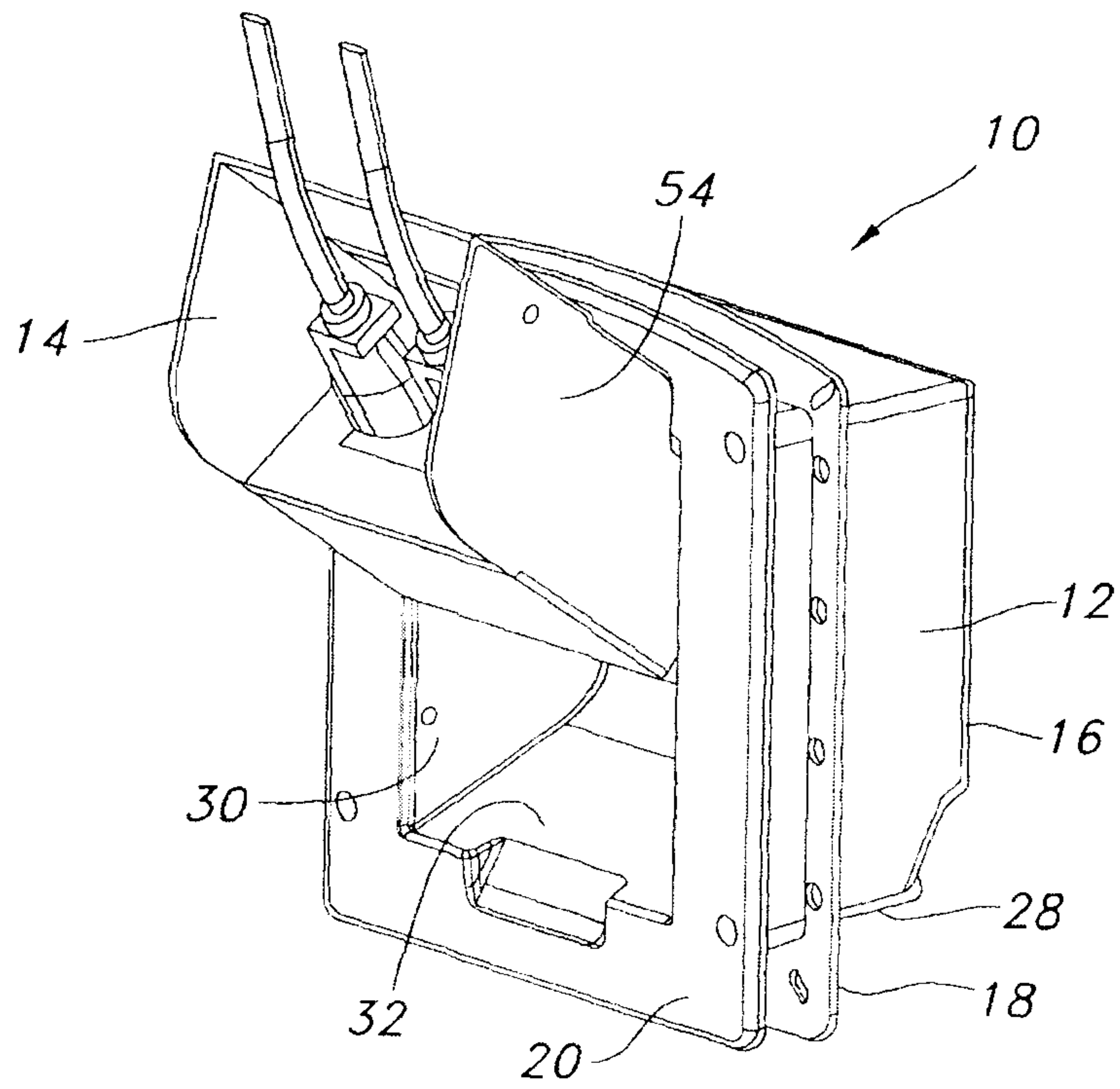

FIG. 1

3/8

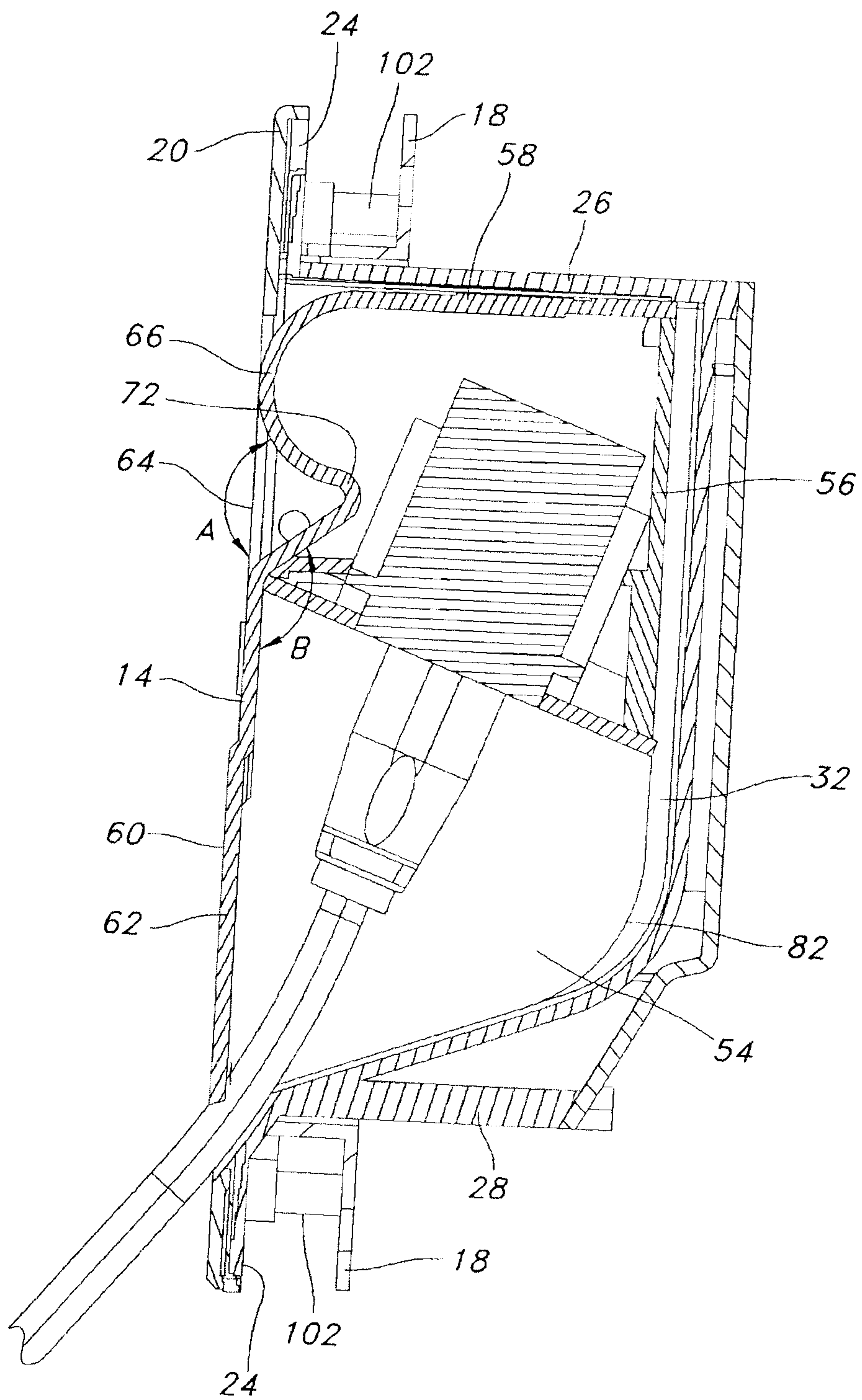

FIG. 3

4/8

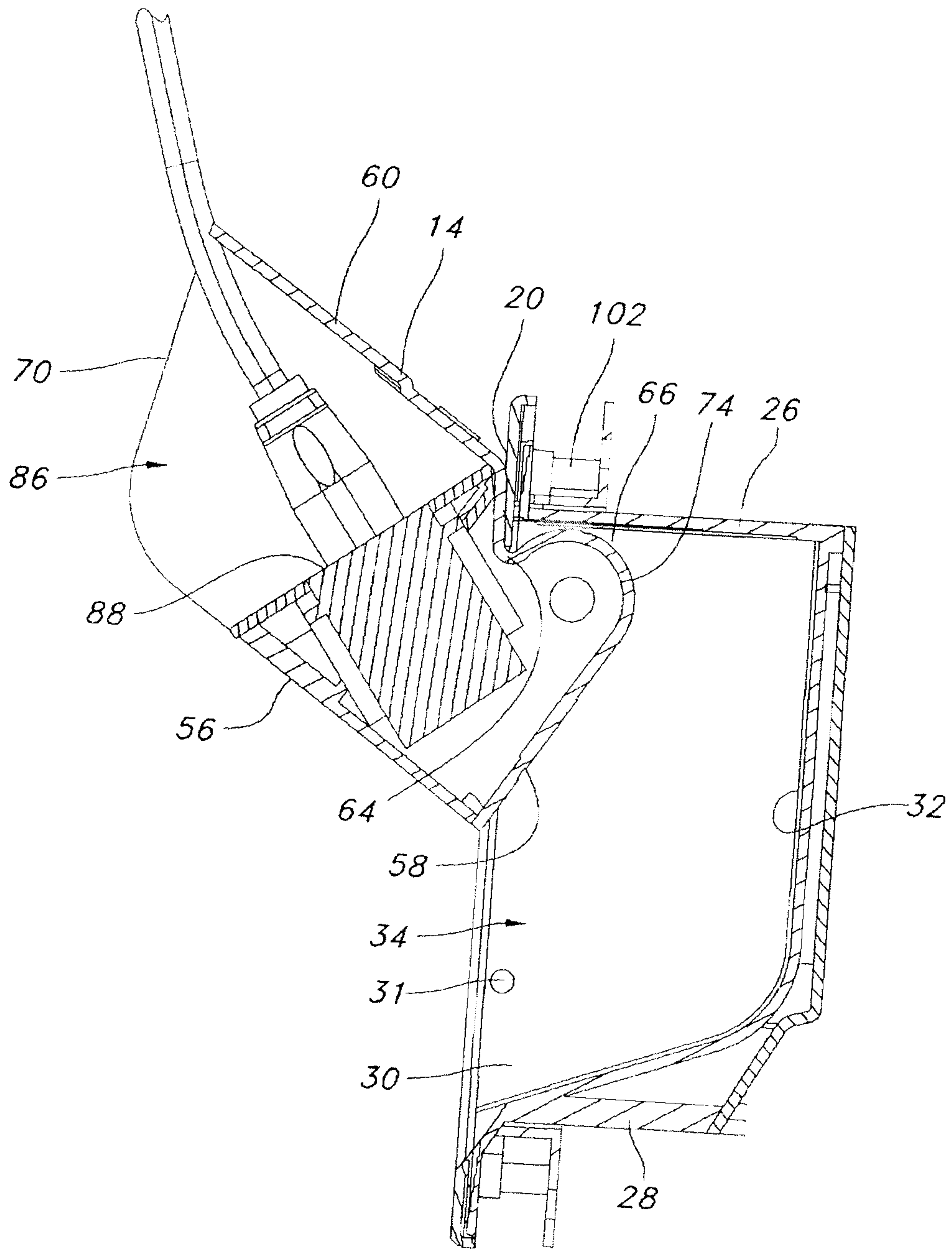

FIG. 4

5/8

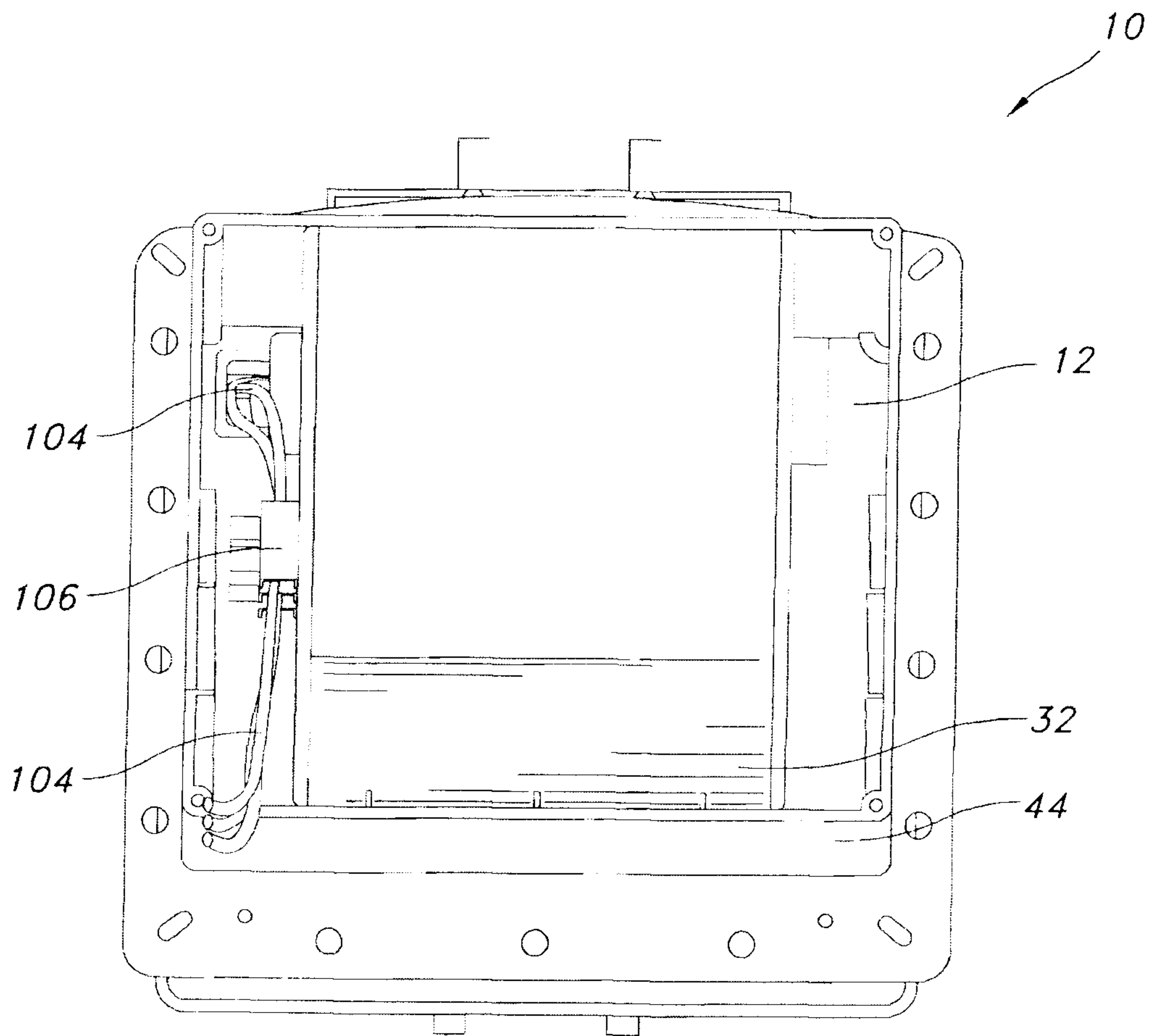

FIG. 5

6/8

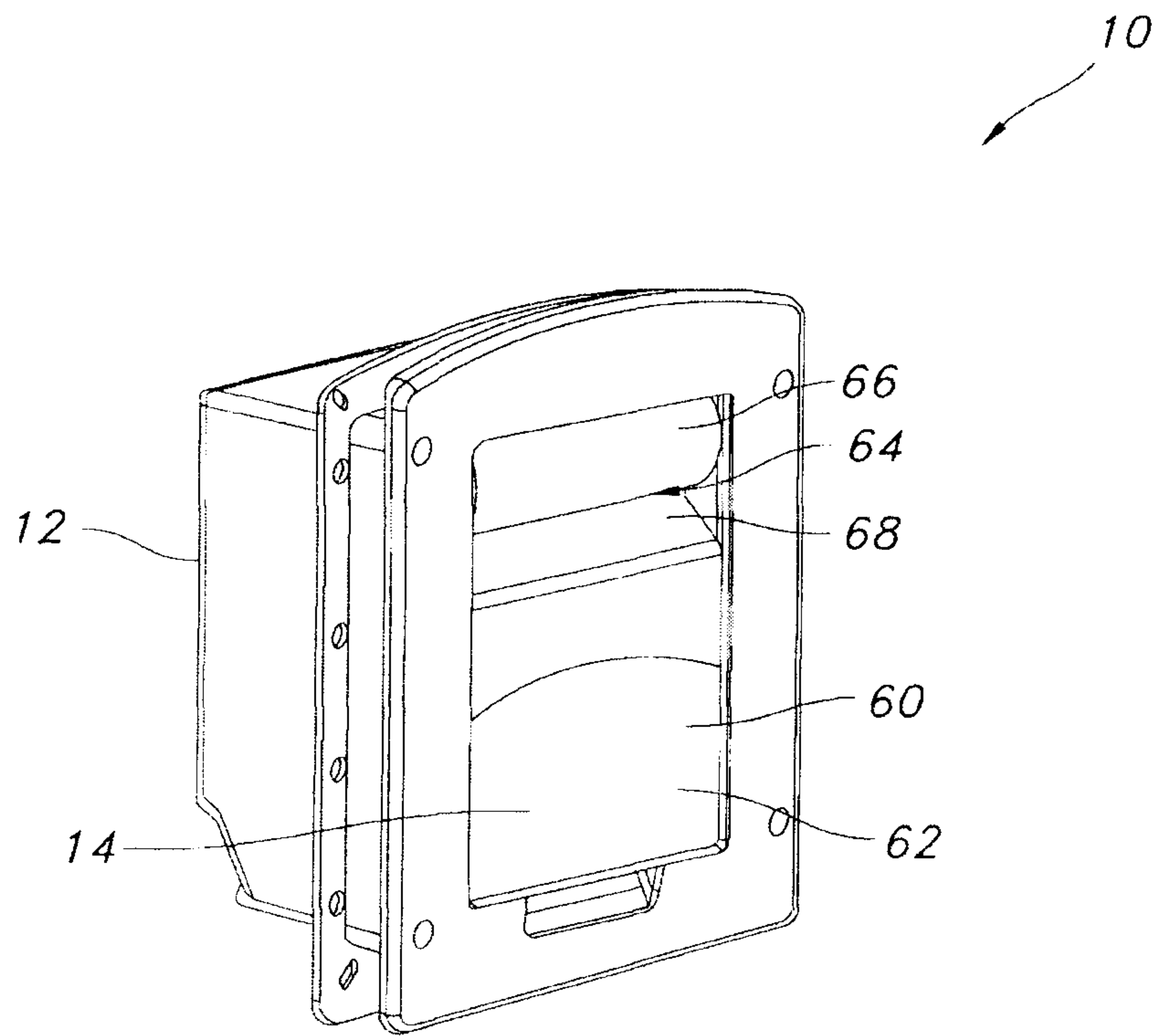

FIG. 6

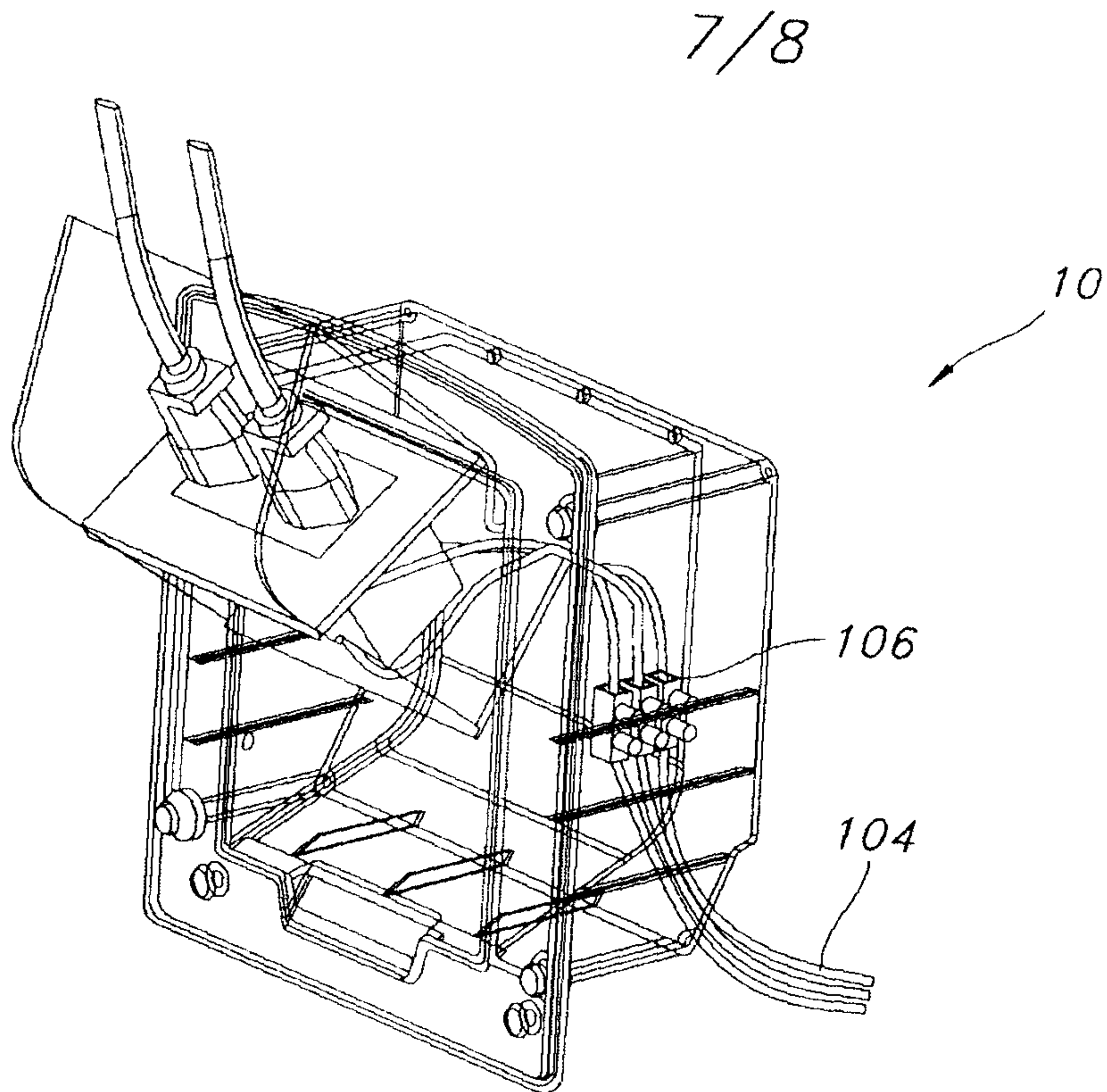

FIG. 7

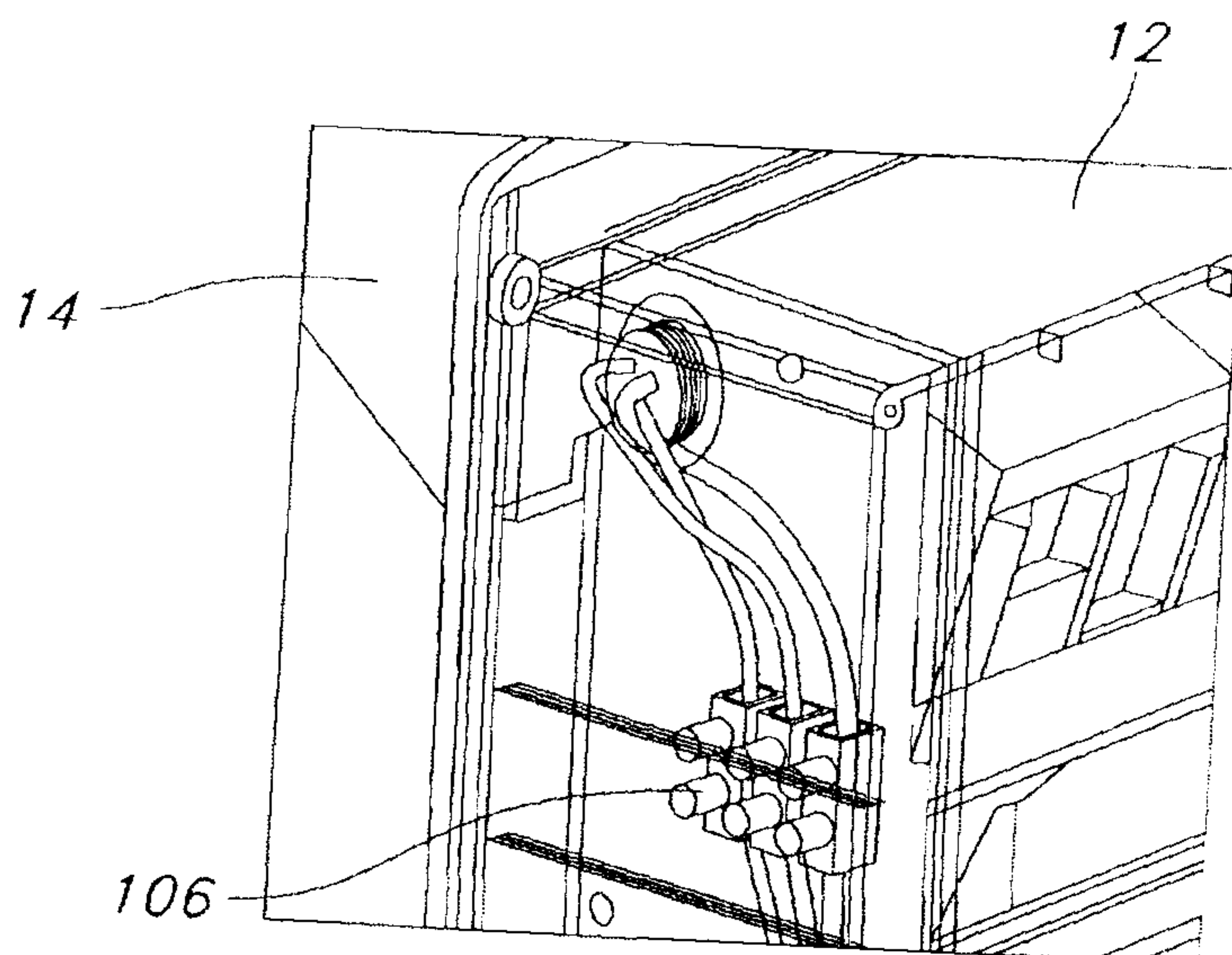

FIG. 8

8/8

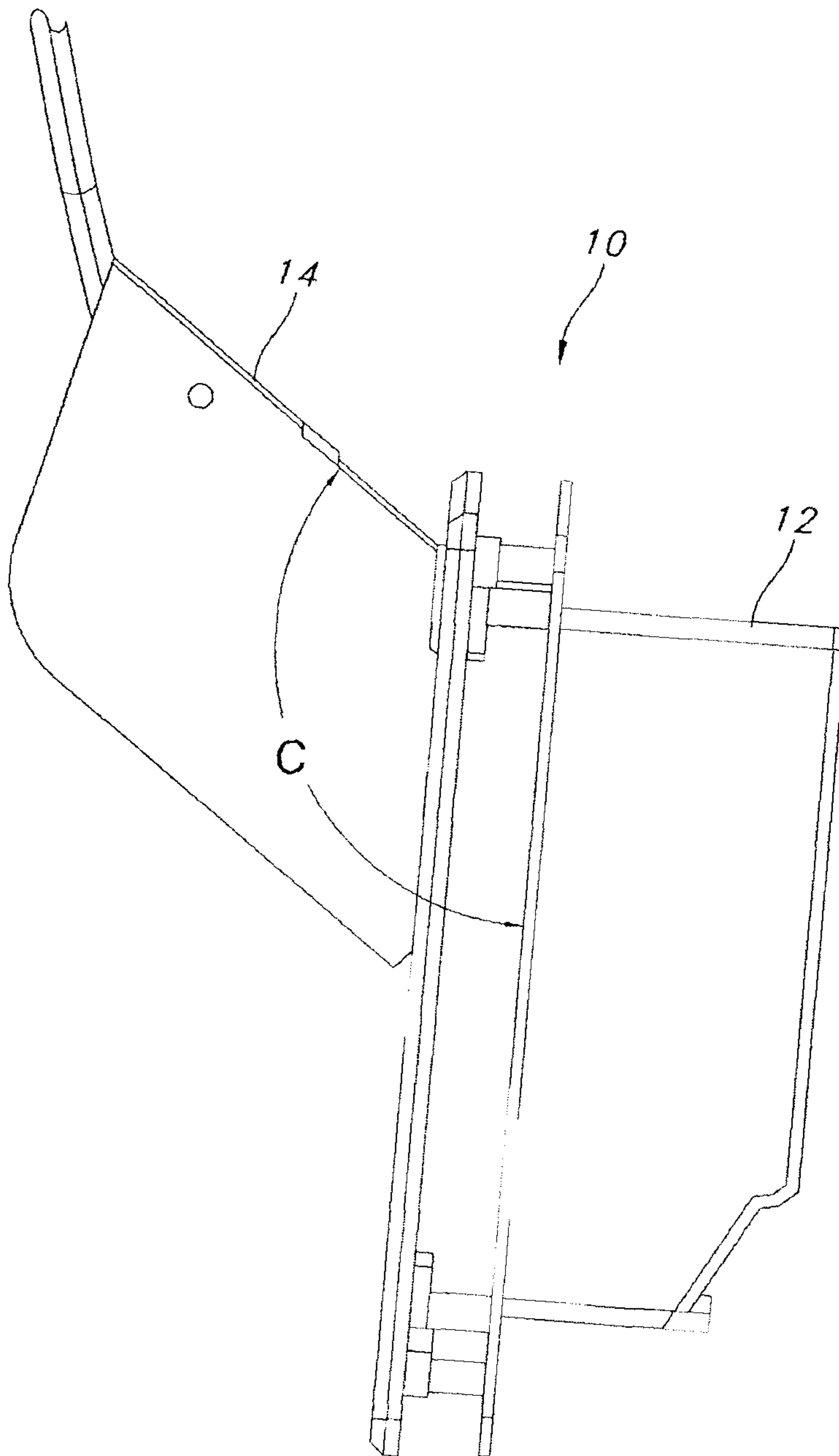

FIG. 9

