

(No Model.)

2 Sheets—Sheet 1.

A. R. KENNEY.

ICE MACHINE.

No. 322,829.

Patented July 21, 1885.

FIG. 1.

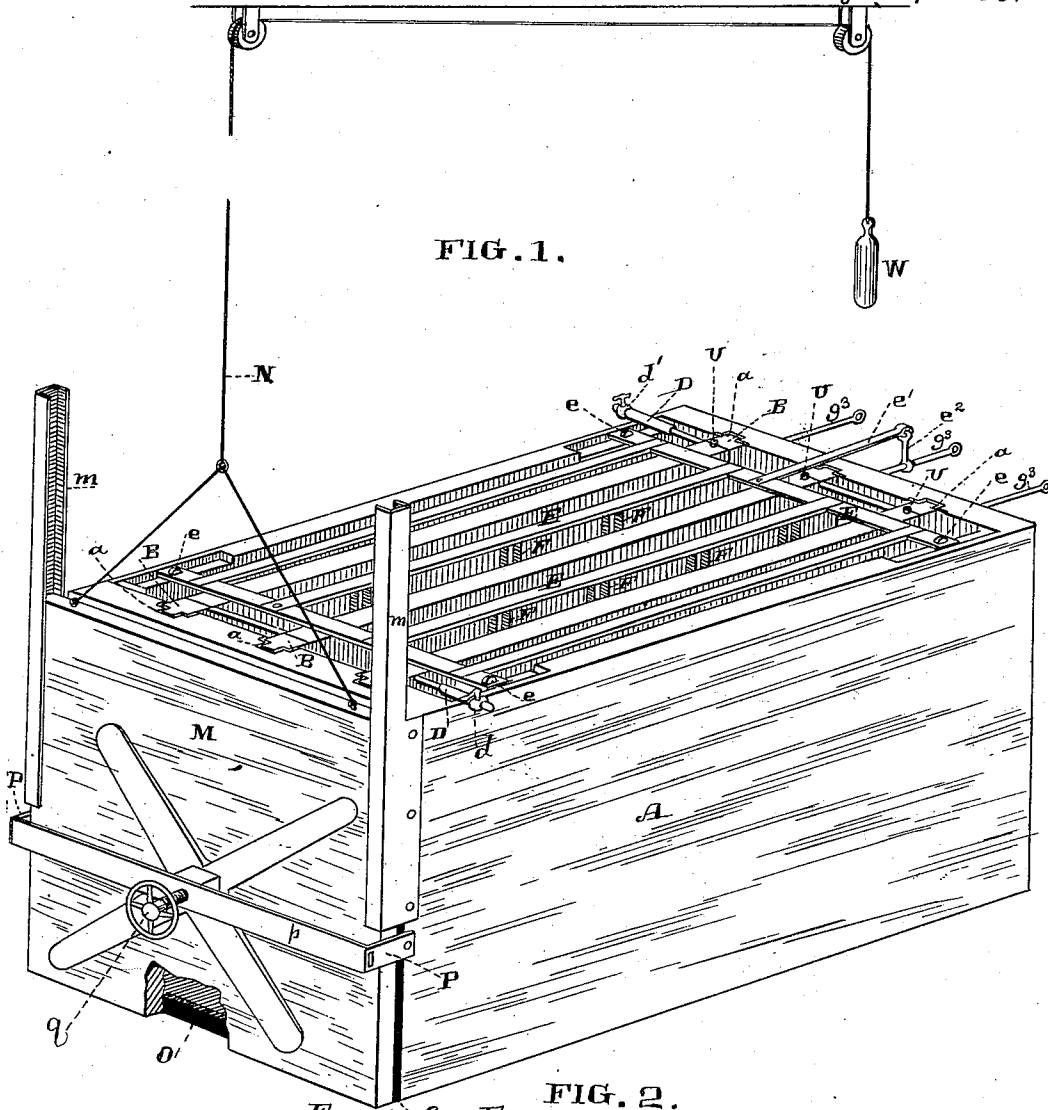
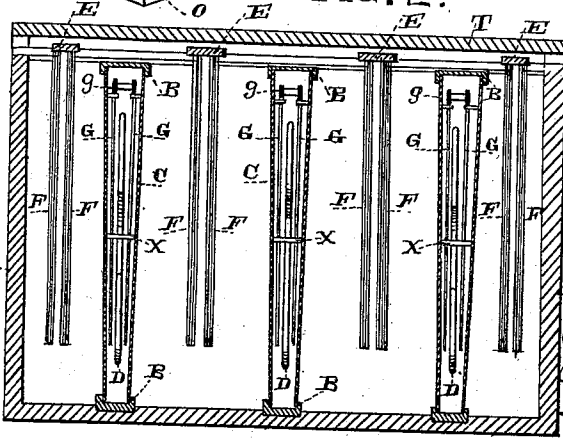

FIG. 2.



Witnesses,
 Geo. B. Strong,
 J. H. Nurse.

Inventor,
 A. R. Kenney
 By
 Dewey & Co.
 Attorneys

(No Model.)

2 Sheets—Sheet 2.

A. R. KENNEY.
ICE MACHINE.

No. 322,829.

Patented July 21, 1885.

FIG. 3.

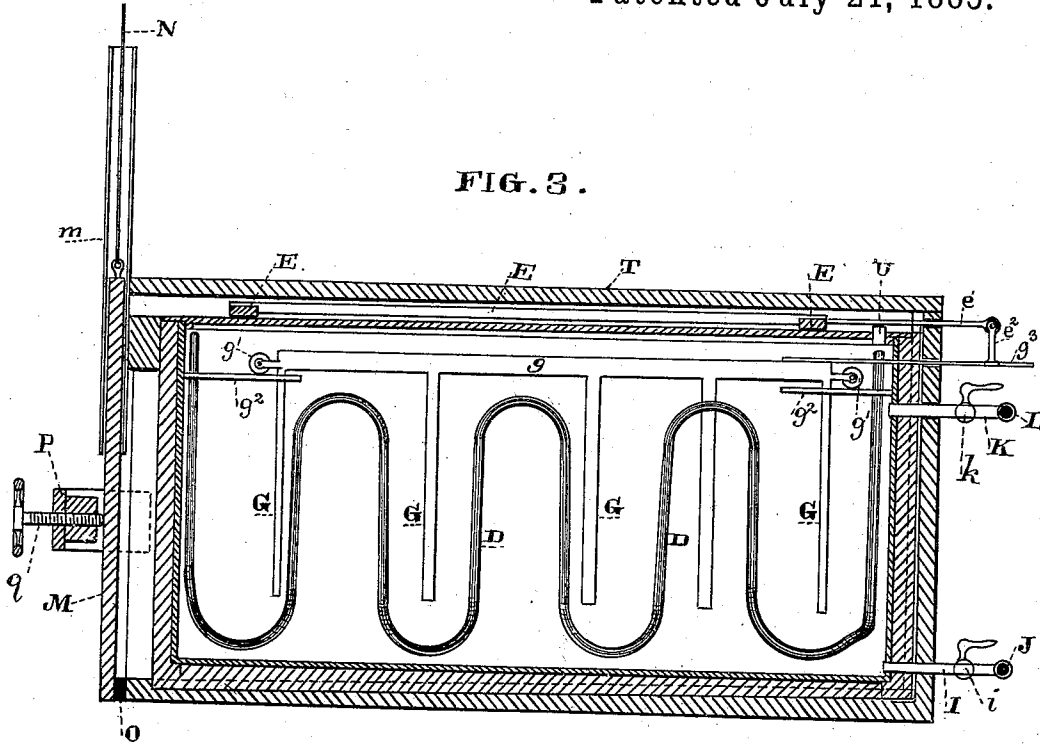
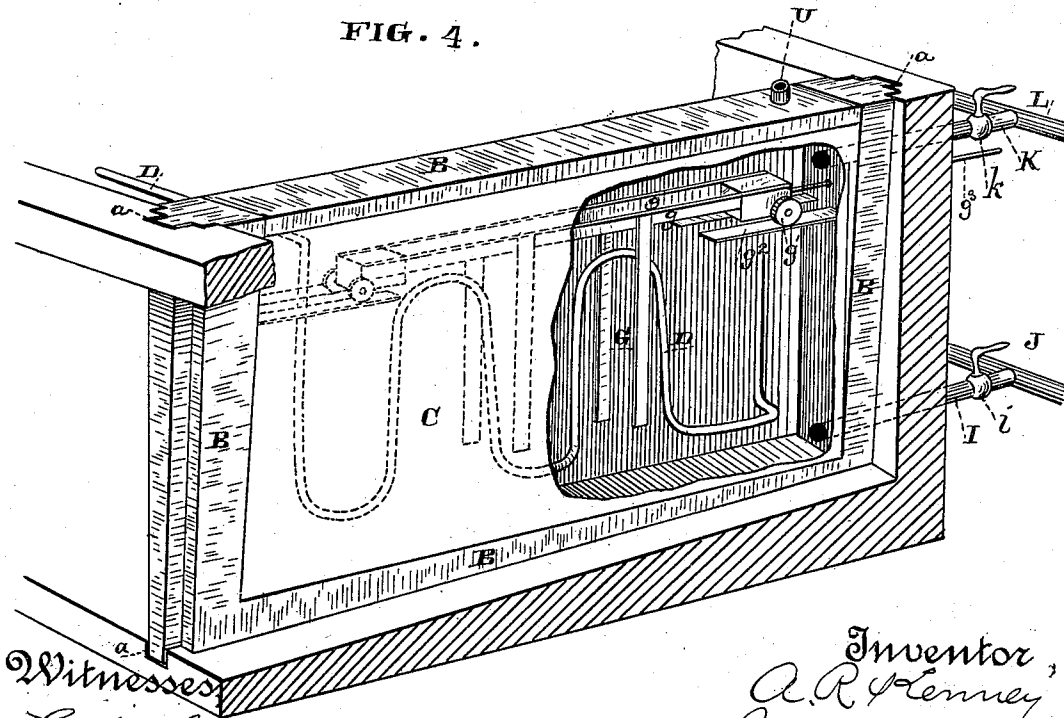

FIG. 4.



Witnesses
 Geo. H. Strong,
 J. T. Bourke.

Inventor,
 A. R. Kenney,
 By
 Dewey & Co.
 Attorneys

UNITED STATES PATENT OFFICE.

AUGUSTUS R. KENNEY, OF SAN FRANCISCO, CALIFORNIA.

ICE-MACHINE.

SPECIFICATION forming part of Letters Patent No. 322,829, dated July 21, 1885.

Application filed March 6, 1885. (No model.)

To all whom it may concern:

Be it known that I, AUGUSTUS R. KENNEY, of the city and county of San Francisco, State of California, have invented an Improvement in Ice-Machines; and I hereby declare the following to be a full, clear, and exact description of the same.

My invention relates to a new and useful ice-machine; and it consists in a box having a sloping bottom and provided with a peculiar vertically-moving end-gate, wedge-shaped and independent, and water-tight closed partitioned cans within the box provided with evaporating-coils, peculiar agitators within the cans and within the compartments of the box formed by the cans, mechanism for reciprocating the agitators, and inlet and overflow and drain pipes and valves by which the cans are supplied, regulated, and drained, all arranged and operated in the manner I shall hereinafter fully describe.

My invention further consists in details of construction relating to the end-gate, the cans, the agitators, and other parts.

The object of my invention is to provide a simple, practical, and effective ice-machine, the several advantages of which I shall describe during the course of the specification.

Referring to the accompanying drawings, Figure 1 is a perspective view of my ice-machine. Fig. 2 is a vertical transverse section of the same. Fig. 3 is a vertical longitudinal section. Fig. 4 is a perspective detail showing one of the refrigerator-cans in position, its side being broken away to show the interior.

A is a box, having in its ends and bottom the grooves *a*. B are frames, of wood or other non-conductor, the bottoms and ends of which fit within the grooves *a* of the box, whereby they can be removed at pleasure, Fig. 4. The frames inclose or encircle cans C, and form a non-conductor around them, removing them from the ends and bottom of the box. These cans are independent of each other. They are water-tight and wedge-shaped, the apex being downward and the base at the top, Fig. 2.

Within each of the cans is the coil D, which consists of a pipe bent or curved vertically, and joining the cans through their tops, as shown. The entrance end of the coil is pro-

vided with a valve, *d*, and its exit end is provided with a similar valve, *d'*.

On the top of the box and cans is a frame, E, consisting of transverse end bars or strips and longitudinal bars or strips, the latter of which carry the agitators F, which consist of slats extending downward into the compartments of the box, which are formed by the cans. The frame E is mounted on small rollers *e*, whereby it may easily receive a reciprocating movement.

Within the cans are the two-part or slotted agitators G, which extend downwardly, straddling the coil, and are mounted on longitudinal strips *g* having small wheeled trucks *g'* on each end traveling on short tracks *g''*, whereby the agitators are adapted to receive a horizontal reciprocating movement, which is imparted by means of stems *g'''* extending through the rear end of the cans and box connected with the wheeled trucks. These stems may be connected to receive a simultaneous movement, or they may be moved separately. With one of the stems the frame E, which carries the agitators F, is connected by means of a pitman, *e'*, and a bar, *e''*, whereby the agitators F are reciprocated simultaneously with the agitators G.

It will be observed that the cans C are so located that they divide the box into compartments, the end or side ones of which are narrower than the others. The cakes of ice being frozen from the sides of the can only and are not intended to meet, it is obvious that in the central and larger compartments there will be two cakes, and in the end compartments but one. The two cakes in the same compartment are not allowed to meet, (as before mentioned,) and in the body of unfrozen liquid between them the agitators F operate. These are therefore located centrally; but in the end compartments they are moved beyond the central longitudinal line, in order to allow the proper space for the formation of the single ice cake. The cans are stiffened by rivets X, which pass through each from side to side.

Each can is supplied with a feed-pipe, U, at its top and with a drain-pipe, I, at its bottom, controlled by a cock, *i*, and united to an escape-pipe, J. They are also provided with overflow-pipes K, controlled by cocks *k*, joined to a common discharge-pipe, L. The

floor or bottom of the box A slopes downwardly from the rear to the front.

Secured to the front of the box are suitable-channeled guides *m*, in which the end-gate M is adapted to move vertically. This gate forms the front end of the box, and consequently, when pushed up, opens said end. It is accurately balanced by means of the chain or cable N, which passes upward to a beam in the ceiling and over suitable pulleys, and has a weight, W, attached to its other end.

In order to cause the gate to form a close and water-tight joint with the front of the box, I have upon the sides and bottom of the box the elastic or rubber packing or washers O. A bracket, P, is secured to the end of the box, and in its front bar, *p*, is a binding-screw, Q, the end of which is adapted to bear against ribs upon the gate, and thus to force said gate against the rubber packing or washers, whereby a close joint is formed.

The bar *p* of the bracket is made removable by reason of fitting in suitable sockets or slots in the end of the arms of the bracket.

The operation of the device is as follows: The gate is lowered, and by means of the binding-screw is pressed tightly to its seat. The sweet water is then poured or allowed to flow into the compartments which the partitional cans form in the box, and then brine or other suitable freezing liquid or agent is supplied to the cans themselves through the supply-pipes U, the overflow-pipes K indicating the quantity to be supplied and when to stop the flow. The evaporating-fluid is then introduced into the coil-pipe D, and at the same time the agitators G F are reciprocated within the compartments and cans.

The object of the closed cans is to prevent variation from outside temperature and concentrate the cold against the sides, not letting it escape, while the object of their wedge shape is as follows: As before explained, each cake is frozen outwardly from the sides only of the cans. These sides being inclined by reason of the wedge shape of the cans, the cake is consequently frozen in a slightly-inclined position, which gives it a tendency, when loosed from the side of the can, to tip over, thereby freeing itself more completely. The cakes are not frozen wedge-shaped, but rectangular, though in an inclined position.

I am aware that an ice-machine is known in which the freezing or sweet water compartments are wedge shape in transverse section; but in this machine the cake of ice is made to fill the entire compartment, and therefore is dependent more upon the shape of the compartment itself than upon any partitional cans, while in my machine my result is more dependent upon and relates particularly to the inclined sides of the partitional cans without any reference to the shape of the compartments, because as my ice cakes do not fill the compartment and are frozen outwardly in straight lines from the cans, they are consequently rectilinear and lie in an inclined po-

sition. In the machine referred to this is not the case, for the cake is a solid one, and is frozen from the top as well as the sides, and is thereby not in an inclined position. My partitional cans are moreover independent of each other. The agitators within the compartments promote the freezing process, and those in the cans equalize the temperature of the freezing agent. The frames B, forming non-conductors holding the cans away from the box, keep the ice cakes free thereof, as they form on the sides of the can only.

The sloping floor of the box enables the operators to withdraw the cakes with greater facility.

When the sweet water is frozen, the controlling-cocks of the escape or drain pipes of the cans are opened, and all the brine or other freezing agent is drawn off. The controlling-cocks of the evaporator-coil are also closed, and the feed-pipes of the cans are opened and sweet water or steam or any melting agent is forced or allowed to flow into them. This agent melts the edges or sides of the cakes, whereby they are freed from the cans, assisted by their tipping or inclined position. After remaining for a suitable length of time the sweet water or other melting agent is drawn off in the same manner that the brine or other freezing agent was drained. The end-gate is then raised, and the blocks of ice are slipped out. When the end-gate is first raised, and before the cakes are taken out, the unmelted water is first allowed to escape and is carried off suitably.

The front bar or the bracket is removed from the end arms in order to allow the cakes to be slipped out.

The box A is provided with a cover, T, over all.

By the arrangement of supply and drain pipes and the controlling-cocks of said pipes, and the evaporator-coil, the machine herein described is well adapted to form one of a connected series the members of which may be simultaneously operated, or one or more may be cut out of the series and operated separately.

It is intended that the supply shall be effected by gravity, and that suitably-inclined floors or chutes shall be provided in front of the boxes, by which the ice cakes may be run off with little trouble.

Having thus described my invention, what I claim as new, and desire to secure by Letters Patent, is—

1. In an ice-machine, the independent partitional water-tight closed refrigerator-cans C, in combination with the vertical evaporator-coil D in said cans, substantially as herein described.

2. In an ice-machine, the independent partitional refrigerator-cans C, for the purpose described, said cans having each a wedge shape, the apex being downward, substantially as herein described.

3. In an ice-machine, the independent par-

partitioned refrigerator water-tight closed cans C, having a wedge shape, substantially as herein described.

4. In an ice-machine, the independent partitioned refrigerator wedge-shaped cans C, in combination with the evaporator-coils D therein, whereby the freezing is effected from the sides of the cans only, substantially as herein described.

5. In an ice-machine, the horizontally-reciprocating agitators G, adapted to stir the refrigerating-brine or other freezing agent, substantially as herein described.

6. In an ice-machine, the partitioned closed refrigerator-cans C, in combination with the horizontally-reciprocating agitators G within said cans and adapted to keep the brine or other freezing agent in motion, substantially as herein described.

7. In an ice-machine, the partitioned closed refrigerator-cans C and the evaporator-coils D therein, in combination with the forked or two-part horizontally-reciprocating agitators G in the cans, straddling the coils, substantially as herein described.

8. In an ice-machine, the partitioned refrigerator-cans C, having short tracks g^2 in each end, in combination with the agitators G within the cans, the strips g , from which they depend, the wheeled trucks g' on the strips and traveling on the tracks, and the stems g^3 , secured to the rear trucks and passing out of the rear of the cans, whereby a horizontal reciprocating movement may be imparted to the agitators, substantially as herein described.

9. In an ice-machine, the box A, divided into a number of parallel sweet-water compartments, as described, in combination with the agitators F in said compartments and the means by which they are horizontally reciprocated, consisting of the frame E, from which the agitators depend, the pitman e' , and bar e^2 , substantially as herein described.

10. In an ice-machine, the box A, and the partitioned refrigerator-cans C dividing the box into a number of sweet-water compartments, in combination with the agitators F in the compartments and the movable frame E from which they depend, the agitators G in the cans, and the movable strips g from which they depend, and the mechanism by which the agitators are simultaneously reciprocated, consisting of the stems g^3 , secured to the strips G and extending through the rear of the cans

and box, and the pitman e' , and bar e^2 , by which the frame E is connected with one of the stems, substantially as herein described.

11. In an ice-machine, the box A, having a vertically-adjustable end-gate, a sloping bottom and grooves a in its ends and bottom, in combination with the independent partitioned refrigerators or brine-cans C, surrounded on top, bottom, and ends by non-conducting-frames B, in which they are mounted, said frames fitting the grooves a in the box and holding the cans free thereof, substantially as herein described.

12. In an ice-machine, the box A in which the cakes are formed, in combination with the vertically-moving balanced door or gate M at one end, substantially as herein described.

13. In an ice-machine having a box in which the cakes are formed, the end-gates M for the box, adapted to move vertically in suitable guides, in combination with the means for securing a tight joint between the gate, when closed, and the end of the box, consisting of the rubber packing or washers O on the ends of the sides and bottom of the box, the bracket P, and the binding-screw Q in the bracket, adapted to press the gate against the packing O, substantially as herein described.

14. In an ice-machine, the box A in which the ice is formed, the rubber packing or washers O on the ends of the sides and bottom of the box, and the bracket P, the front bar, p , of which is removable to permit the withdrawal of the ice, in combination with the vertically-moving gate M, and the binding-screw Q in the bracket adapted to press the gate to its seat against the packing, substantially as herein described.

15. An ice-machine consisting of the box A, the vertically-moving end-gate M, the closed partitioned and wedge-shaped refrigerator-cans C, dividing the box into compartments in which the ice cakes are formed, said cans having inlet and outlet pipes, the evaporator-coils D in the cans, and the horizontally-reciprocating agitators F G in the compartments and cans, all arranged and adapted to operate substantially as herein described.

In witness whereof I have hereunto set my hand.

AUGUSTUS R. KENNEY.

Witnesses:

C. D. COLE,
J. H. BLOOD.