



(51) International Patent Classification:

A61B 5/00 (2006.01) A61B 5/0408 (2006.01)
A61B 18/14 (2006.01)

(21) International Application Number:

PCT/CA2014/000010

(22) International Filing Date:

10 January 2014 (10.01.2014)

(25) Filing Language:

English

(26) Publication Language:

English

(30) Priority Data:

13/775,322 25 February 2013 (25.02.2013) US

(71) Applicant: **MEDTRONIC CRYOCATH LP** [CA/CA];
199 Bay Street, Suite 5300, Toronto, Ontario M5L 1B9
(CA).

(72) Inventor: **DEAC, Ioana Alina**; 3056 Rue Labelle,
Vaudreuil-Dorion, Québec J7V 8H8 (CA).

(74) Agent: **MOFFAT & CO.**; P.O. Box 2088, Station D, Ott-
awa, Ontario K1P 5W3 (CA).

(81) Designated States (unless otherwise indicated, for every
kind of national protection available): AE, AG, AL, AM,
AO, AT, AU, AZ, BA, BB, BG, BH, BN, BR, BW, BY,

BZ, CA, CH, CL, CN, CO, CR, CU, CZ, DE, DK, DM,
DO, DZ, EC, EE, EG, ES, FI, GB, GD, GE, GH, GM, GT,
HN, HR, HU, ID, IL, IN, IR, IS, JP, KE, KG, KN, KP, KR,
KZ, LA, LC, LK, LR, LS, LT, LU, LY, MA, MD, ME,
MG, MK, MN, MW, MX, MY, MZ, NA, NG, NI, NO, NZ,
OM, PA, PE, PG, PH, PL, PT, QA, RO, RS, RU, RW, SA,
SC, SD, SE, SG, SK, SL, SM, ST, SV, SY, TH, TJ, TM,
TN, TR, TT, TZ, UA, UG, US, UZ, VC, VN, ZA, ZM,
ZW.

(84) Designated States (unless otherwise indicated, for every
kind of regional protection available): ARIPO (BW, GH,
GM, KE, LR, LS, MW, MZ, NA, RW, SD, SL, SZ, TZ,
UG, ZM, ZW), Eurasian (AM, AZ, BY, KG, KZ, RU, TJ,
TM), European (AL, AT, BE, BG, CH, CY, CZ, DE, DK,
EE, ES, FI, FR, GB, GR, HR, HU, IE, IS, IT, LT, LU, LV,
MC, MK, MT, NL, NO, PL, PT, RO, RS, SE, SI, SK, SM,
TR), OAPI (BF, BJ, CF, CG, CI, CM, GA, GN, GQ, GW,
KM, ML, MR, NE, SN, TD, TG).

Declarations under Rule 4.17:

— as to applicant's entitlement to apply for and be granted a
patent (Rule 4.17(ii))

Published:

— with international search report (Art. 21(3))

(54) Title: RETRACTABLE MAPPING JACKET

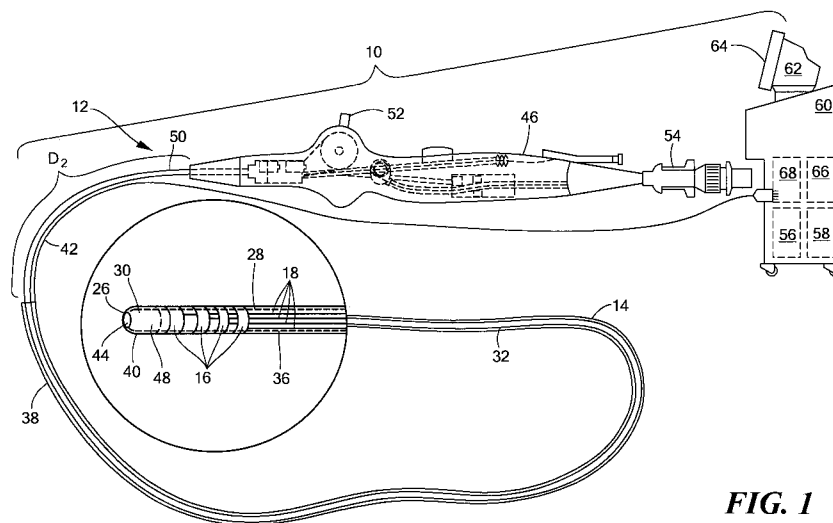
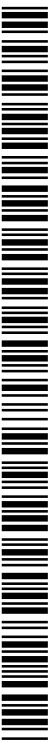

FIG. 1

(57) Abstract: An accessory and system to provide a medical device with mapping and ablation functionality. The system may include an ablation device with a handle, a treatment element, and an elongate body. The ablation element may be located on the elongate body distal portion, and a mapping sleeve may be disposable about at least part of the distal portion of the ablation device and may include mapping electrodes disposed on the outer surface. The mapping sleeve proximal region may include a retraction element defining a proximal end and a distal end, the distal end being coupled to the proximal region of the mapping sleeve, such that retracting the retraction element toward the elongate body proximal portion pulls the mapping sleeve away from the treatment element of the ablation device.



RETRACTABLE MAPPING JACKET

FIELD OF THE INVENTION

The present invention relates to a device and system for integrating ablation and mapping functionality into a single medical device. In particular, the present invention relates to a cost-effective accessory that adds mapping functionality to an ablation device after production.

BACKGROUND OF THE INVENTION

Catheter ablation is commonly used to treat a variety of cardiovascular conditions, such as cardiac arrhythmias, atrial fibrillation, and other irregularities in the transmission of electrical impulses through the heart. This minimally invasive surgical technique may involve the use of tip electrodes or other ablating elements to create lesions or other anatomical effects that disrupt or block electrical pathways through the targeted tissue. In the treatment of cardiac arrhythmias, a specific area of cardiac tissue having aberrant electrical activity (e.g. focal trigger, slow conduction, excessively rapid repolarization, fractionated electrogram, etc.) is typically identified first before subsequent treatment.

It is advantageous to identify an optimal ablation site before ablating the tissue. Presently, this procedure may require mapping an area of tissue with a first mapping device. Once an optimal ablation site is identified, the mapping device is withdrawn and replaced with an ablation device. However, this practice may increase the chances of patient injury or procedure complications, and may disadvantageously increase the total time needed to treat a condition. Alternatively, presently known devices may include mapping and ablation functionality in a single device, which may reduce procedure time and complexity by eliminating the need to employ separate mapping and ablation devices for each task. Combination mapping and ablation devices also increase ablation accuracy, because once aberrant tissue (the “target tissue”) is found, ablation can begin immediately without having to remove the mapping device and relocating the target tissue with the ablation device. However, such devices may require complicated manufacturing steps and expensive materials, may present insulation problems between mapping and ablation electrodes, and may be prohibitively expensive for some surgeons.

It is therefore desirable to provide a system and device for performing both mapping and ablation at a reduced cost over presently known devices. It is further desirable to provide mapping and ablation functionality in a single device that is easy to operate and cost-effective to manufacture.

5

SUMMARY OF THE INVENTION

The present invention advantageously provides a medical device accessory and system with mapping and ablation functionality. The accessory may generally include a resilient sleeve defining an inner surface and an outer surface, and a mapping electrode disposed on the outer surface of the resilient sleeve. The resilient sleeve may define a proximal portion and a distal portion, and the proximal portion may define a proximal edge and the distal portion defining a distal tip including an aperture. The resilient sleeve may further include a retraction element coupled to the proximal portion of the resilient sleeve. Additionally, the device may comprise an electrode wire in electrical communication with the mapping electrode. The wire may be fused to the inner surface of the resilient sleeve. The resilient sleeve may define a primary lumen and a secondary lumen, each having a longitudinal axis, and the secondary lumen may be disposed within the primary lumen, such that the longitudinal axes of the primary and secondary lumens are substantially parallel. The resilient sleeve may include a plurality of coextruded layers, and the wire may be disposed between two coextruded layers. Further, the proximal portion of the resilient sleeve may include a proximal edge, and the retraction element may be coupled to the proximal edge and extend for a distance that is uncoupled from the proximal edge. The retraction element may define a lumen, the wire being disposed within the lumen. The accessory may further include a plurality of mapping electrodes and a plurality of electrode wires. For example, the plurality of wires may be composed of a conductive material that is printed onto the outer surface of the resilient sleeve.

The system may generally include an ablation device including an ablation element and an elongate body defining a distal portion, a proximal portion, and a longitudinal axis, the ablation element being located on the distal portion of the elongate body, a resilient mapping sleeve disposable about at least the ablation element of the distal portion of the ablation device, the mapping sleeve defining an

30

inner surface, an outer surface, and a primary lumen having a longitudinal axis. The system may further include a power generator and a plurality of mapping electrodes disposed on the outer surface of the mapping sleeve, each of the plurality of mapping electrodes including an electrode wire that is coupled directly to the power generator.

5 Pulling the mapping sleeve toward the proximal portion of the elongate body pulls the mapping sleeve away from the ablation element, thereby exposing it in order to ablate target tissue. The mapping sleeve may further define a proximal region and a distal region including an exit opening sized to allow at least a portion of the distal portion of the elongate body to pass therethrough. The mapping sleeve may further define a

10 retraction element, the retraction element being coupled to the proximal portion of the mapping sleeve. Exerting a pull force on the retraction element may retract the mapping sleeve toward the proximal region of the elongate body and expose the ablation element. At least a region of the elongate body and the treatment element may protrude from the exit opening of the mapping sleeve when the mapping sleeve is

15 retracted. The mapping sleeve may further define a secondary lumen having a longitudinal axis, and the longitudinal axes of the primary lumen and secondary lumen may be substantially parallel. Each of the plurality of mapping electrodes may include an electrode wire, and the plurality of electrode wires may be coupled to an inner surface of the mapping sleeve primary lumen, printed onto the outer surface of

20 the mapping sleeve, or disposed within the secondary lumen.

In another embodiment, the system may include an ablation device including a handle, a treatment element, and an elongate body defining a distal portion, a proximal portion, and a length, the ablation element being located on the distal portion of the elongate body, a mapping sleeve disposable about at least the treatment

25 element, the mapping sleeve having a length that is less than the length of the elongate body, a plurality of mapping electrodes disposed on the outer surface of the mapping sleeve, and a retraction element defining a proximal end and a distal end, the distal end being coupled to the proximal region of the mapping sleeve, retraction of the retraction element toward the handle pulling the mapping sleeve away from and

30 exposing the treatment element of the ablation device.

BRIEF DESCRIPTION OF THE DRAWINGS

A more complete understanding of the present invention, and the attendant advantages and features thereof, will be more readily understood by reference to the following detailed description when considered in conjunction with the accompanying drawings wherein:

5 FIG. 1 shows a first embodiment of a system including a mapping sleeve and an ablation device according to the present invention;

 FIG. 2 shows a treatment device including a mapping sleeve disposed over at least a portion of the distal region of the treatment device, such that a treatment element is covered by the mapping sleeve;

10 FIG. 3 shows the treatment device of FIG. 2 with the mapping sleeve retracted to expose the treatment element;

 FIG. 4 shows a first embodiment of a distal tip of a mapping sleeve;

 FIG. 5 shows a second embodiment of a distal tip of a mapping sleeve;

15 FIG. 6 shows a cross-sectional view of a first embodiment of a mapping sleeve;

 FIG. 7 shows a cross-sectional view of a second embodiment of a mapping sleeve;

 FIG. 8 shows a cross-sectional view of a third embodiment of a mapping sleeve;

20 FIG. 9 shows a proximal region of a mapping sleeve;

 FIG. 10 shows a second embodiment of a system including a mapping sleeve and a treatment device according to the present invention;

25 FIG. 11A shows a cross-sectional view of the treatment device of FIG. 10, the mapping sleeve disposed over at least a portion of the distal region of the treatment device, such that the treatment element is covered by the mapping sleeve; and

 FIG. 11B shows a cross-sectional view of the treatment device of FIG. 10, with the mapping sleeve retracted to expose the treatment element.

DETAILED DESCRIPTION OF THE INVENTION

30 Referring now to FIG. 1, a system 10 that includes a treatment device 12 and a device accessory 14 is shown. The device accessory may be a mapping jacket or sleeve 14 on which one or more mapping electrodes 16 are borne. For example, the

mapping electrodes 16 may be suitable for recording electrocardiogram signals within cardiac tissue. The mapping electrodes 16 may be composed of an electrically conductive material that is affixed to, fused with, or printed onto the mapping sleeve 14. Further, the mapping electrodes 16 may be ring or band electrodes (as shown in FIG. 1). Each mapping electrode 16 may include an electrode wire 18. The wires 18 may be affixed to or fused with the mapping sleeve 14 (for example, an inner surface 20 of the sleeve 10), and the wires 18 contained between the mapping sleeve 14 and device 12 (as shown in FIG. 6), contained within a lumen 22 of the mapping sleeve (as shown in FIG. 7), or disposed between two extrusion layers of the mapping sleeve (as shown in FIG. 8). Alternatively, the wires 18 may be composed of a conductive material that is printed on the outer surface 24 of the sleeve (as shown in FIG. 1). The mapping sleeve 14 may be composed of a soft, flexible, resilient, biocompatible material, such as nylon, Pebax, silicone, or polyvinylchloride (PVC).

The mapping sleeve 14 may be substantially tube shaped with a substantially closed distal tip 26. That is, the mapping sleeve 14 may have a primary lumen 28 within which at least a portion of the device 12 may be inserted, the distal tip 26 of the sleeve 14 being proximate the distal tip 30 of the device 12. The inner diameter of the primary lumen 28 may be sufficient to accommodate the device 12 within the sleeve 14. For example, the sleeve 14 may be configured to fit over an elongate body 32 of a device 12 with a 7 French diameter. Further, there may be a small gap 34 between an inner surface 20 of the sleeve 14 and the elongate body 32 so that the sleeve 14 may be smoothly retracted without putting strain on the distal region 36 of the device 12 (for example, as shown in FIGS. 6-8). However, the gap 34 may be thin enough that the sleeve 14 is not pulled from the device 12 as the device 12 is navigated to the target tissue. The mapping sleeve 14 may define a proximal region 38 and a distal region 40, and may include one or more cables, cords, wires, or other retraction elements 42 (as shown and described in more detail in FIG. 9). The distal tip 26 of the mapping sleeve 14, although substantially closed, may be configured to allow the device 12 to pass therethrough when the mapping sleeve 14 is retracted (for example, as shown and described in more detail in FIGS. 4 and 5). That is, the distal tip 26 of the mapping sleeve 14 may include an aperture or opening 44. In an alternative embodiment shown and described in FIGS. 10 and 11, the mapping sleeve

14 may be integrated with the device 12 from a handle 46 of the device 12 to a distance D_1 from the distal tip 30 of the device 12. Along this distance D_1 to the distal tip 30 of the device 12, the mapping sleeve 14 may not be integrated with the device 12 but may be configured as a separate sleeve disposed about at least a portion of the distal portion 36 of the device 12.

The mapping sleeve 14 may be a distance D_2 shorter than the elongate body 32 of the device 12, so that the sleeve 14 may be retracted away from one or more treatment elements 48 at the distal region 36 of the elongate body 32. As a non-limiting example, the sleeve 14 may be between at least approximately 5 inches and approximately 6 inches shorter than the elongate body 32 of the device, and may be up to 15 inches or more, as long as the sleeve 14 may be retracted away from the distal region 36 of the elongate body 32 without becoming bunched at the proximal region 50 of the elongate body 32 where it joins the handle 46. Further, at least a portion of the mapping sleeve 14 may remain outside of the patient throughout the mapping and ablation procedures. As a non-limiting example, a typical 7-French focal catheter may have a usable length of approximately 108.5 cm. A mapping sleeve 14 used with such a catheter 12 may be approximately 70 cm. The distance D_2 , 38.5 cm (approximately 15 in), by which the sleeve 14 is shorter than the elongate body 32 may be used to retract the mapping sleeve 14 toward the handle 46. At least a portion of the proximal region 38 of the sleeve 14 may remain outside of the patient during mapping and treatment (for example, ablation) procedures. For example, at least a portion of the proximal region 38 of the sleeve 14 may extend from an incision made in a patient to allow femoral, radial, or brachial access to the device 12.

The system 10 may be used with a device such as a focal catheter used for cryoablation or other types of ablation including radiofrequency (RF), ultrasound, microwave, and/or ultrasound ablation. The catheter 12 may include an elongate body 32 defining a proximal region 50, a distal region 36, and one or more lumens therebetween, such as fluid, mechanical, or electrical lumens (not shown). The elongate body 32 may be passable through a patient's vasculature and/or proximate to a tissue region for diagnosis or treatment, such as a catheter, sheath, or intravascular introducer. The elongate body 32 may include one or more bellowed regions or it may have a smooth outer surface. Further, the elongate body distal region 36 may

include one or more treatment elements 48 such as treatment electrodes and/or thermal exchange areas. As a non-limiting example, the distal tip 30 of the elongate body 32 may be composed of a thermally conductive material such as metal. A refrigerant may be circulated within the distal tip 30, and the cooled tip used to cryoablate target tissue. Further, the treatment electrodes 48 may be used to apply RF, ultrasound, microwave, or other ablation energy, or to apply high voltage energy to electroporate target tissue.

The catheter 12 may include a handle 46 coupled to the proximal region 50 of the elongate body 32. The handle 46 may include one or more actuators, wheels, knobs, or other steering control elements 52 for steering the device 12. In an alternative embodiment, the actuators 52 of the handle may be used to retract the mapping sleeve 14. Further, the handle 46 may include circuitry for identification and/or use in controlling of the medical device or another component of the system. For example, the handle 46 may include one or more pressure sensors to monitor the fluid pressure within the catheter. The handle 46 may also include connectors 54 that are matable directly to a fluid reservoir 56, fluid recovery reservoir 58, and/or console 60 or indirectly by way of one or more umbilicals. The handle 46 may further include blood detection circuitry in fluid and/or optical communication with one or more fluid delivery pathways throughout the system. The handle 46 may also include a pressure relief valve in fluid communication with the one or more fluid pathways to automatically open under a predetermined threshold value in the event that value is exceeded.

The console 60 may include one or more computers 62, each having a display 64, one or more user input devices, and one or more processors for executing algorithms, programs, and/or calculations, and for generating images, alerts, maps, instructions, system feedback or status signals, and/or user input options on the display. The system 10 may further include one or more coolant reservoirs 56, coolant recovery reservoirs 58, power sources 66, energy generators 68, and/or vacuum pumps for evacuating expanded coolant from the device distal region 36. The system 10 described herein may be configured to deliver one or a combination of energy modalities, for example, radiofrequency energy, microwave energy, ultrasound energy, cryoablation, electroporation, and combinations thereof. Further, the system

10 and device 12 may be configured to deliver one or more treatment agents (for example, genes, proteins, or other substances that affect cells of the target tissue).

Referring now to FIGS. 2 and 3, a treatment device 12 including a mapping sleeve 14 disposed over at least a portion of the distal region 36 of the treatment device 12 is shown, the mapping sleeve 14 covering a treatment element 48 of the device 12 and retracted to expose the treatment element 48, respectively. FIGS. 2 and 3 show the device 12 with mapping sleeve 14 disposed within the right atrium of the heart, although it will be understood that the device may be used to map other anatomical features and other areas within the heart. A close-up view of the device 12 with sleeve 14 is shown in the inset of each figure. The mapping sleeve 14 may be disposed about all or at least a portion of the distal region 36 of the elongate body 32 of the device 12. In an alternative embodiment, as shown and described in FIGS. 10 and 11, the mapping sleeve 14 may be integrated with the ablation device 12 from the proximal region 50 of the elongate body 32 at the handle 46 to a location within the distal region 36 of the elongate body 32 but a distance D_1 from the distal tip 30 of the elongate body 32. The device 12 may be delivered to a target area of tissue with the mapping sleeve 14 being disposed about the elongate body 32 (as shown in FIG. 2). Once the mapping electrodes 16 are in contact with the target tissue, the mapping electrodes 16 may be activated to record cardiac electrical signals, such as electrocardiogram (ECG) signals. Alternatively, the mapping electrodes 16 may passively record signals such as monophasic action potential signals. The device 12 may be moved to a new area of target tissue and the new area mapped, until a target treatment site is identified. Once the target treatment site is identified, a user (for example, a surgeon) may pull on portion of the proximal region 38 of the mapping sleeve 14 that is external to the patient and/or the retraction elements 42 to manually retract the mapping sleeve 14. Alternatively, the user may manipulate one or more controls 52 within the handle 46 of the device 12 to retract the mapping sleeve 14, if the one or more retraction elements 42 are in communication with the handle 46. Retraction of the sleeve 14 exposes one or more treatment elements 48 (as shown in FIG. 3). For example, once the sleeve 14 is retracted from the distal tip 30 of the elongate body 32, the device 12 may be activated to ablate or treat the tissue. Further, the treatment and/or ablation portions of the device 12 may have a larger “footprint”

than the mapping portions of the sleeve. It may be desirable to use the sleeve 14 with a device 12 having a large treatment element 48 or large area over which multiple treatment elements 48 are arranged, thus being able to create a large lesion in the tissue at the treatment site. In this case, the mapping sleeve 14 may provide mapping
5 functionality without sacrificing space on or within the device 12 that would otherwise be dedicated to treatment elements. Further, the mapping electrodes 16 may have less spacing between them than do the ablation elements 48, which may enhance the quality of recorded mapping signals.

Referring now to FIGS. 4 and 5, a first and second embodiment of a distal tip
10 26 of the mapping sleeve 14 are shown. As shown and described in FIGS. 2 and 3, the mapping sleeve 14 may be retracted from the distal region 36 of the elongate body 32 of the device to expose one or more treatment elements 48 for treating tissue. Accordingly, the distal dip 26 of the sleeve 14 may include an aperture or opening 44 through which the device may be passed. As non-limiting examples, FIG. 4 shows a
15 slit-type opening 44 and FIG. 5 shows a flap-type opening 44. Additionally, a hole-type opening 44 is shown in FIG. 1. No matter the shape or structure of the opening 44, the stretchable, resilient, and flexible nature of the sleeve 14 may allow a device 12 to pass through the opening 44 that has a diameter that is approximately the same as, or up to several times greater than, the diameter of the opening 44. Additionally,
20 the configuration of the opening 44 (for example, the slit-type or flap-type opening) may maintain a substantially closed configuration when disposed about the distal region 36 of the elongate body 32, only opening when the sleeve 14 is retracted to allow the device 12 to pass through.

Referring now to FIGS. 6-8, cross-sectional views of a first, second, and third
25 embodiment of a mapping sleeve 14 are shown. These cross-sectional views illustrate the disposition of the electrode wires 18 within the mapping sleeve 14. In the embodiment shown in FIG. 6, the electrode wires 18 are disposed between the mapping sleeve 14 and the elongate body 32 of the device 12. Each wire 18 may extend from a mapping electrode 16 at the wire distal region 70 to the console 60 or
30 console component, such as an energy generator 68, computer 62, processor, or the like at the wire proximal region 72. Alternatively, the wire 18 may extend to the handle 46 at the wire proximal region 72. The handle 46, in turn, may be coupled to

the console 60 via one or more cables, umbilicals, conduits, or the like. To prevent the wires 18 from becoming entangled with each other or with the device 12 when the sleeve 14 is retracted, the wires 18 may be fused within or affixed to an inner surface 20 of the sleeve 14 between the sleeve 14 and the device 12 or fused within or affixed to an outer surface 24 of the sleeve 14. However, each wire 18 may include an exposed region between the proximal region of the sleeve and the handle, or each wire 18 may be disposed within or encased within a retraction element 42 (as shown in FIG. 9), or each wire 18 may be fused within or affixed to an inner 20 or outer 24 surface of the sleeve 14 for a length of the elongate body 32, to the handle 46 or proximate the handle 46 (as shown in FIG. 10). In FIG. 7, the sleeve 14 may include a dedicated wire lumen 22 that continues along a length of the sleeve 44, from the mapping electrodes 16 to the proximal edge 74 of the sleeve 14. The wire lumen 22 may have a circular cross section; however, in an alternative space-saving configuration, the wire lumen 22 may have an elongate, hemispherical, or other non-round cross section. The wires 18 may be contained within the lumen 22 and thus directed in a bundle along the mapping sleeve 14. In FIG. 8, the wires 18 may be disposed within extrusion layers 76 of the sleeve 14. For example, the sleeve 14 may include two or more layers 76 that are coextruded during the manufacturing process with the wires 18 disposed between them. In the non-limiting embodiment shown in FIG. 8, the sleeve 14 may include an inner layer 76' and an outer layer 76'', between which the wires 18 extend from the mapping electrodes 16 at the distal region 70 to the proximal edge 74 of the sleeve 14.

Referring now to FIG. 9, a proximal region 38 of a mapping sleeve 14 of FIG. 1 is shown. The sleeve 14 may include one or more cables, cords, wires, or other retraction elements 42. As used herein, the term "retraction element" refers to any structure coupled to the mapping sleeve 14 that is used to retract the mapping sleeve 14, connect the mapping sleeve 14 to the handle 46 and/or console 60 or console component, and/or house the wires 18 proximal of the mapping sleeve 14. Although a user may manually pull the mapping sleeve 14 portion that is external to the patient to retract the mapping sleeve 14 from one or more treatment elements 48 within the patient, the mapping sleeve 14 is not itself referred to as a "retraction element." The one or more retraction elements 42 may be in communication with one or more

actuators, wheels, knobs, or other control elements 52 for retracting the mapping sleeve 14. For example, rotation of a knob or wheel 52 within the handle 46 may wind up a portion of the retraction element 42, thereby retracting the mapping sleeve 14 from the one or more treatment elements 48 of the device 12. Alternatively, the user may pull on the one or more retraction elements 42 to retract the mapping sleeve 14 manually.

The one or more retraction elements 42 may be coupled to an outer surface 24 of the sleeve 14. Further, the retraction element 42 may be composed of the same material as the sleeve 14 (and, indeed, may be formed with the sleeve during manufacturing), or it may be composed of another material such as one or more biocompatible polymers or metals. The proximal region 38 of the sleeve 14 may define a proximal edge 74, and the retraction elements 42 may be coupled to the sleeve 14 at or near this proximal edge 74. Further, at least a portion of the proximal region 38 of the sleeve 14 near the proximal edge 74 may be reinforced with an extra layer of material, an integrated ring or cuff 78 of a material having a higher durometer than the sleeve material, or the like, to strengthen the sleeve against breakage or tearing when the retraction elements 42 are pulled to retract the sleeve 14. Any number of retraction elements 42 may be used. In the non-limiting embodiment shown in FIG. 9, the proximal region 38 of the sleeve 14 may include a tube that is composed of the same material as and integrated with the mapping sleeve 14. Further, the tube 42 may define a lumen 80 within which the wires 18 are disposed. If the sleeve 14 includes a dedicated wire lumen 22, the wire lumen 22 may be substantially coaxial with the lumen 80 of the retraction element 42. Alternatively, as shown in FIG. 9, the wires 18 may be fused to an inner surface 20 of the sleeve 14 and enter the retraction element 42 lumen 80 as a bundle. The retraction element 42 may also serve as a connector between the mapping sleeve 14 and console 60 or console element, such as the energy generator 68 or computer 62 (as shown in FIG. 1). Further, the wires 18 may be contained within the retraction element 42 until the point of connection with, for example, the console 60 or console component, which may keep the wires 18 together and prevent snagging or damage. Alternatively, the wires 18 may be independent of the retraction element 42 for a distance proximal the console 60 or console component. Configuring the wires 18 to be directly

connectable to the console 60 or console element instead of the handle 46 allows the mapping sleeve 14 to be used as an accessory that is independent of the device 12 and easily adds mapping functionality to an existing device 12.

Referring now to FIGS. 10-11B, a second embodiment of a system including a mapping sleeve 14 and a treatment device 12 according to the present invention and a cross-sectional view of the mapping sleeve 14 and ablation device 12 are shown. The system 10 of FIG. 10 may generally be same as the system 10 shown and described in FIGS. 1-9. Further, the use of the treatment device 12 and mapping sleeve 14, and disposition of the mapping electrodes 16 and mapping electrode wires 18, of FIGS. 10-11B may generally be the same as that shown and described in FIGS. 1-9. However, the mapping sleeve 14 of the embodiment of FIGS. 10-11B may be integrated with at least a portion of the device 12. For example, the mapping sleeve 14 may be composed of a biocompatible material similar to that of which the elongate body 32 of the device 12 is composed, but the mapping sleeve 14 material may have a lower durometer than the elongate body 32 material, such that the mapping sleeve 14 forms an outer layer that is softer or more flexible than the elongate body 32. For simplicity, the mapping sleeve 14 and elongate body 32 of the device 12 will still be referred to separately; in practice, however, the sleeve 14 and elongate body 32 will together comprise a medical device 12 with integrated mapping and ablation functionality. That is, the mapping sleeve 14 and elongate body 32 will be integrated into a single elongate, flexible body 82 extending from the handle 46.

As described above, the mapping sleeve 14 as shown in FIGS. 10-11B may be integrated with the elongate body 32 from, for example, the handle 46 to a location within the distal region 36 of the elongate body 32 that is a distance D_1 proximal from the one or more treatment elements 48 (for example, ablation electrodes that may be at or proximate the distal tip 30 of the elongate body 32). Along distance D_1 to the distal tip 30 of the elongate body 32, the mapping sleeve 14 may be separated from the elongate body 32 and form a discrete layer over at least the portion of the elongate body 32 that includes the treatment elements 48 (as shown in FIG. 11A). The mapping sleeve 14 material along the length of distance D_1 may be folded in on itself, allowing the mapping sleeve 14 to be retracted from the treatment element 48. This feature is shown in the cross-sectional view of FIGS. 11A and 11B. Further, the distal

tip 26 of the mapping sleeve 14 may include an opening 44, for example, as shown and described in FIGS. 6-8.

Once the mapping sleeve 14 is used to record mapping signals from the target tissue (for example, electrocardiogram signals), the mapping sleeve 14 may be
5 retracted from the one or more treatment elements 48 by sliding the softer mapping sleeve 14 layer over the firmer elongate body 32, toward the handle 46 (as shown in FIG. 11B). For example, a user may perform this step by hand, without using actuators 52 within the handle 46. The distance D_1 over which the mapping sleeve 14 is not integrated with the elongate body 32 may be a function of both the distance
10 over which the one or more treatment elements 48 are disposed in the distal region 36 of the elongate body 32, and the durometer difference between the mapping sleeve 14 and the elongate body 32. As the mapping sleeve 14 is retracted from the one or more the treatment elements 48, the distance D_1 may be reduced, as shown in FIG. 11B. Mapping sleeve wires 18 may be connected to the handle 46 or they may be
15 connected directly to the console 60 or console element, as described above, for example, regarding FIG. 9.

It will be appreciated by persons skilled in the art that the present invention is not limited to what has been particularly shown and described herein above. In addition, unless mention was made above to the contrary, it should be noted that all of
20 the accompanying drawings are not to scale. A variety of modifications and variations are possible in light of the above teachings without departing from the scope and spirit of the invention, which is limited only by the following claims.

What is claimed is:

1. A medical device, comprising:
a resilient sleeve defining an inner surface and an outer surface; and
a mapping electrode disposed on the outer surface of the resilient sleeve.
5
2. The medical device of Claim 1, wherein the resilient sleeve defines a proximal portion and a distal portion, the proximal portion defining a proximal edge and the distal portion defining a distal tip including an aperture.
- 10 3. The medical device of Claim 2, wherein the resilient sleeve further comprises a retraction element coupled to the proximal portion of the resilient sleeve.
4. The medical device of Claim 3, further comprising an electrode wire in electrical communication with the mapping electrode.
15
5. The medical device of Claim 4, wherein the wire is fused to the inner surface of the resilient sleeve.
6. The medical device of Claim 4, wherein the resilient sleeve defines a
20 primary lumen and a secondary lumen, each of the primary lumen and secondary lumen having a longitudinal axis.
7. The medical device of Claim 6, wherein the secondary lumen is disposed within the primary lumen, the longitudinal axes of the primary and
25 secondary lumens being substantially parallel.
8. The medical device of Claim 4, wherein the resilient sleeve includes a plurality of coextruded layers.
- 30 9. The medical device of Claim 8, wherein the wire is disposed between two coextruded layers.

10. The a medical device of Claim 4, wherein the proximal portion of the resilient sleeve includes a proximal edge, the retraction element being coupled to the proximal edge and extending for a distance that is uncoupled from the proximal edge.
- 5 11. The medical device of Claim 11, wherein the retraction element defines a lumen, the wire being disposed within the lumen.
12. The medical device of Claim 2, wherein the aperture defines a flap.
- 10 13. The medical device of Claim 4, wherein the accessory comprises a plurality of mapping electrodes and a plurality of electrode wires.
14. The medical device of Claim 13, wherein the plurality of wires are composed of a conductive material that is printed onto the outer surface of the
15 resilient sleeve.
15. The medical device of Claim 1, further including:
an ablation device including an ablation element and an elongate body defining a distal portion, a proximal portion, and a longitudinal axis, the ablation
20 element being located on the distal portion of the elongate body; and
the resilient mapping sleep being disposable about at least the ablation element of the distal portion of the ablation device.

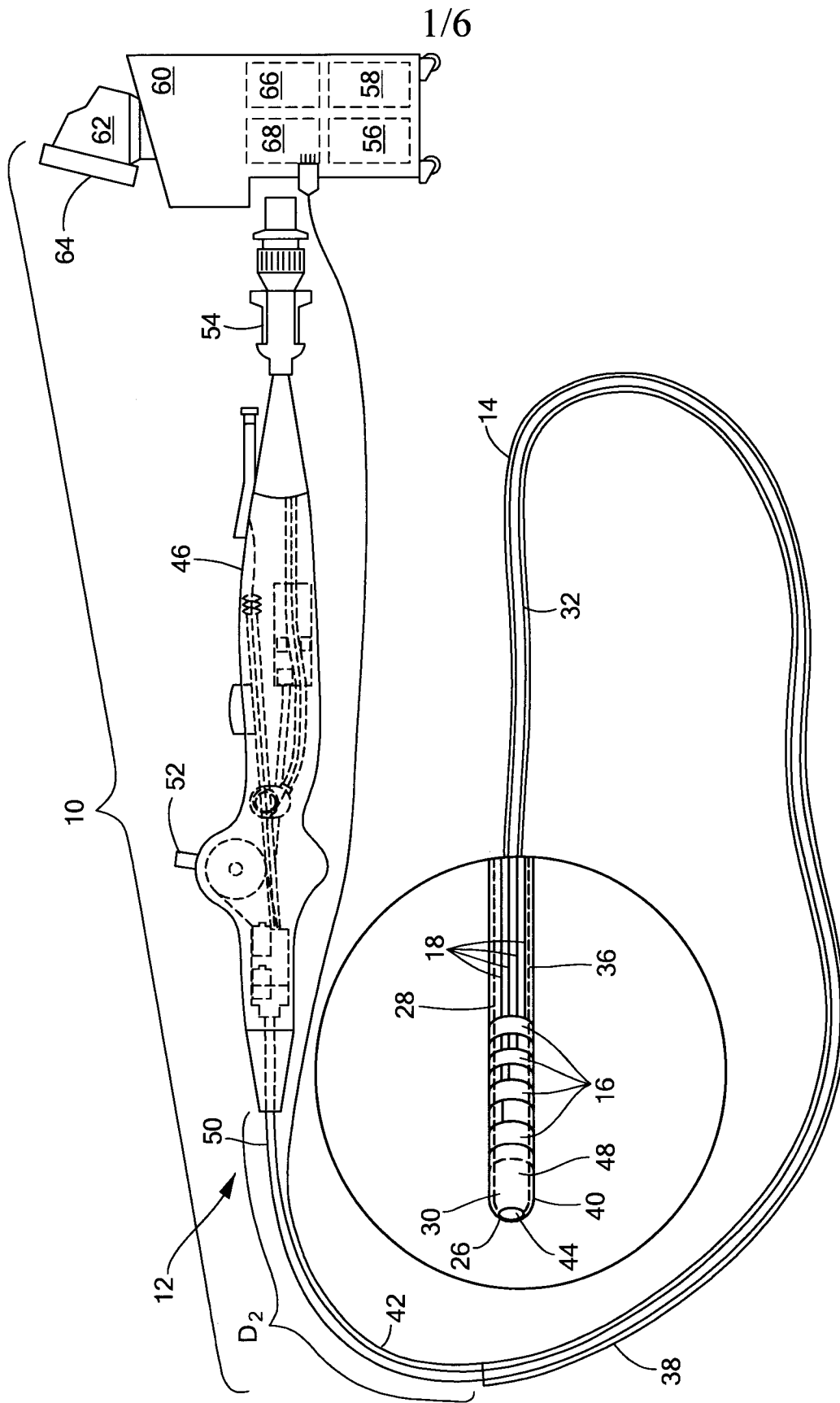
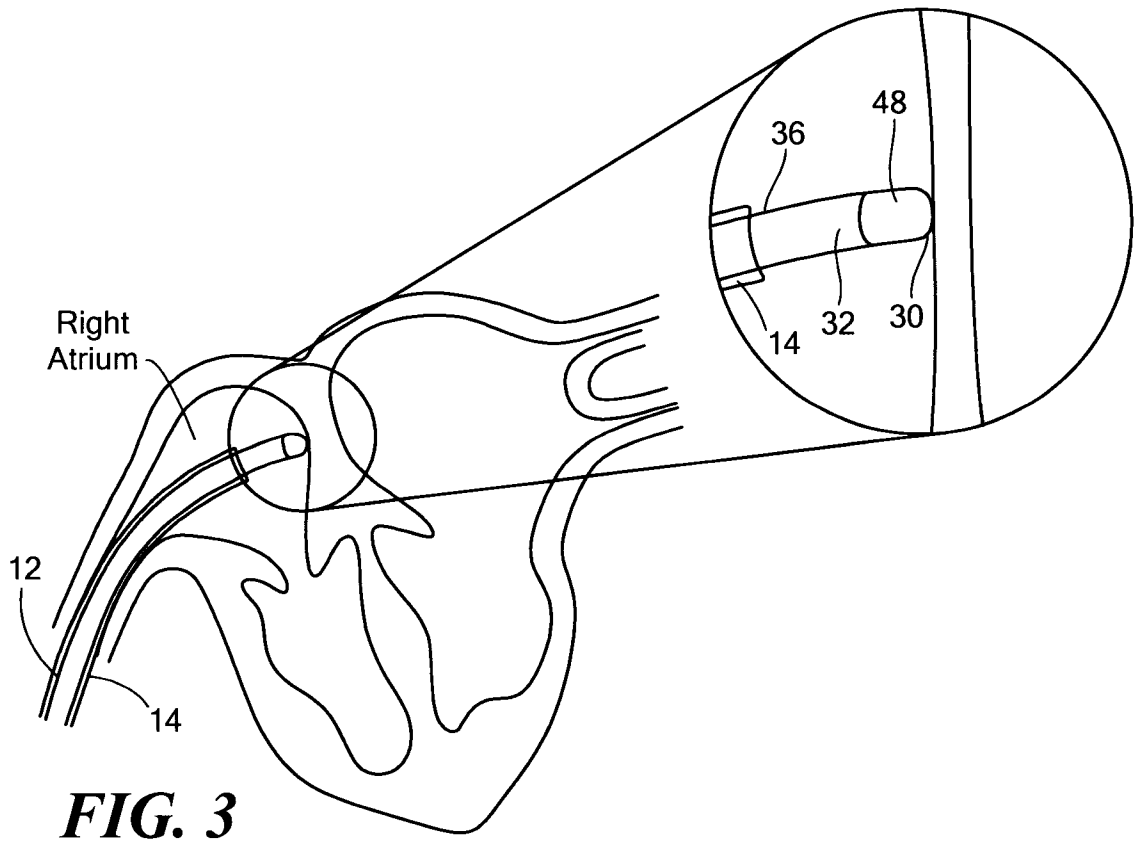
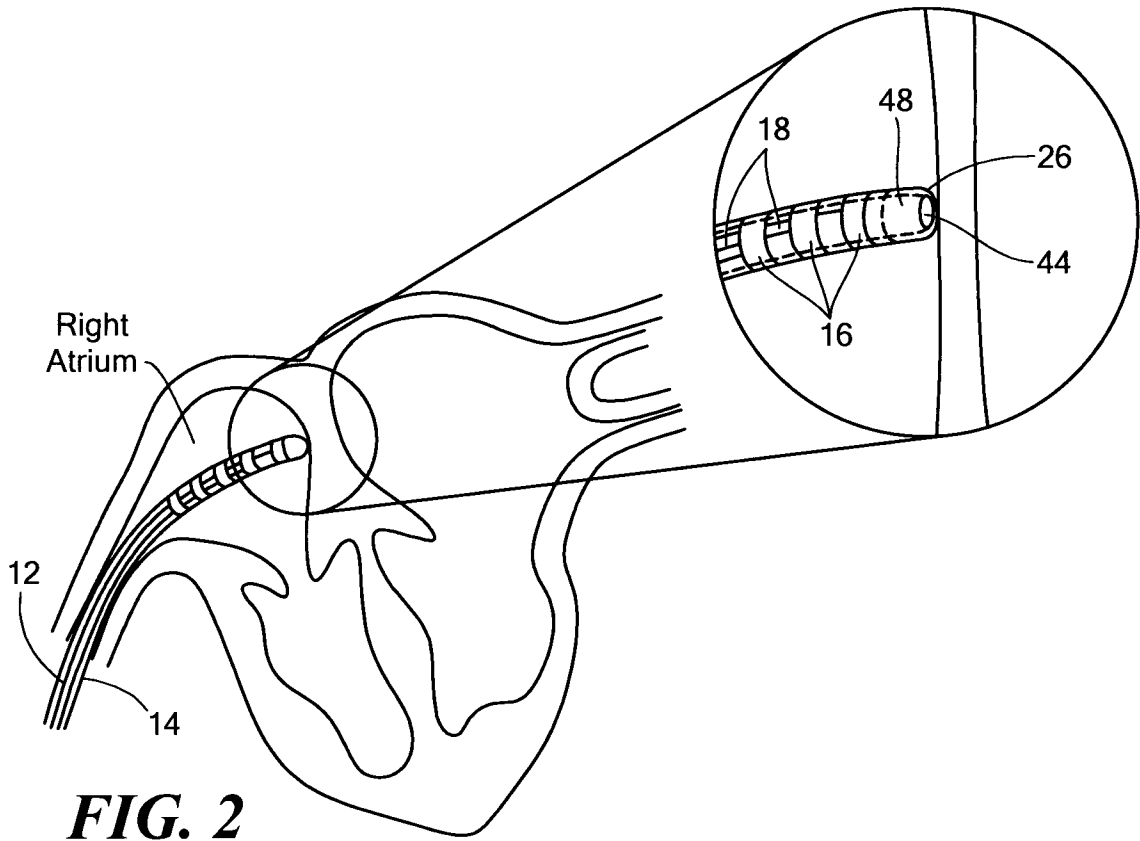

FIG. 1



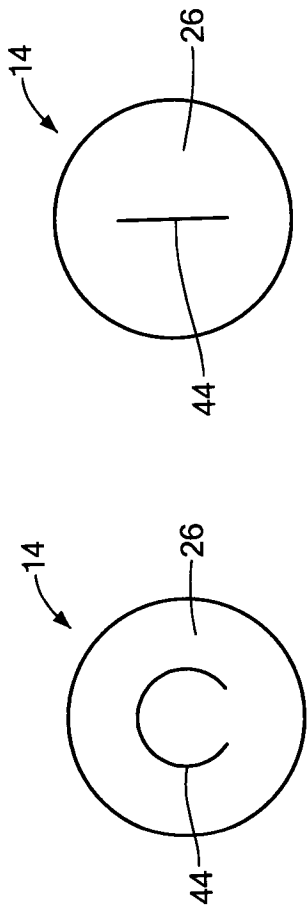

FIG. 5

FIG. 4

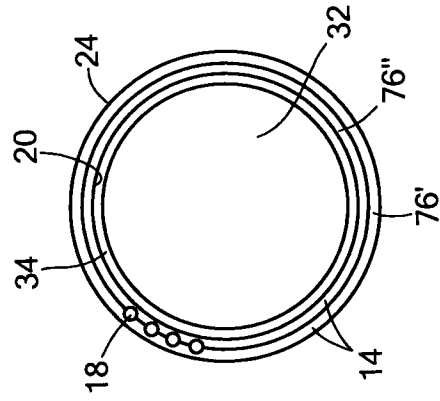

FIG. 8

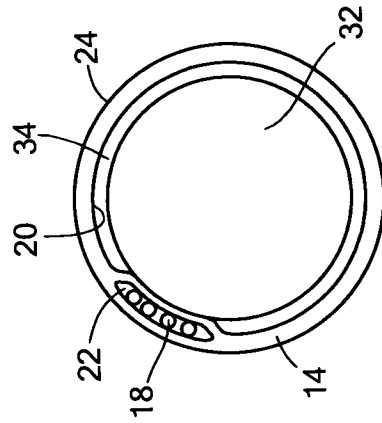

FIG. 7

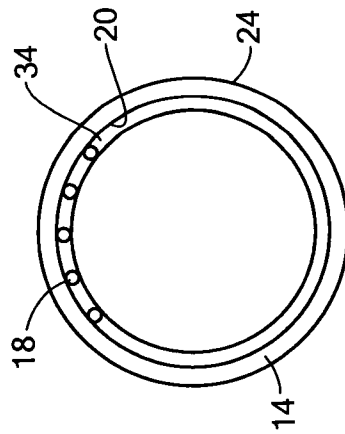

FIG. 6

4/6

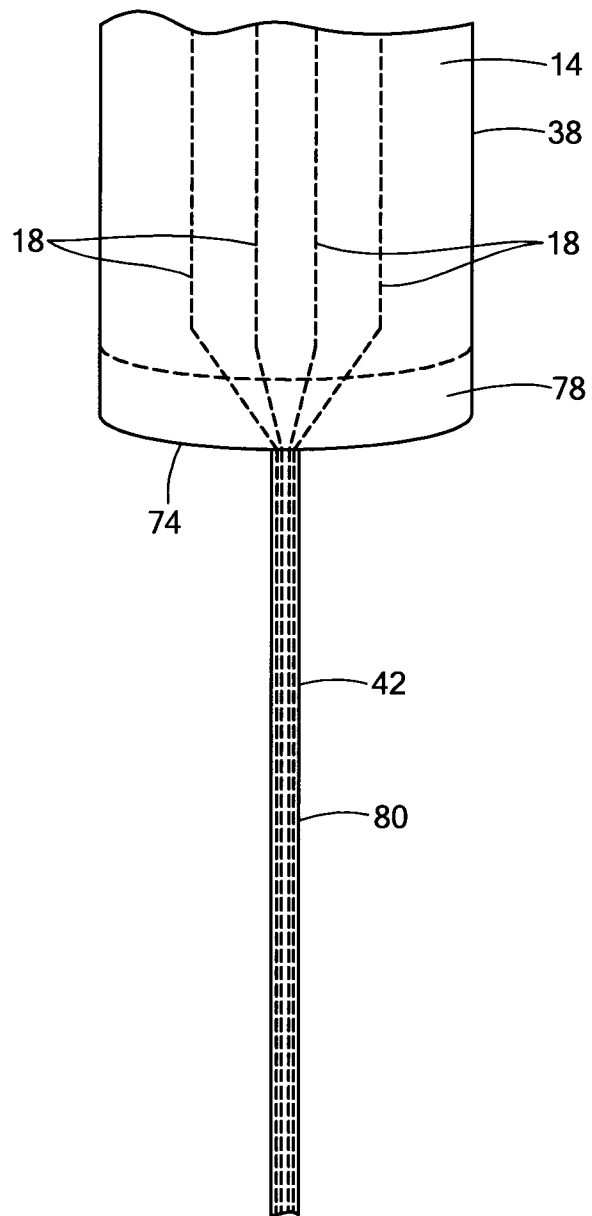

FIG. 9

5/6

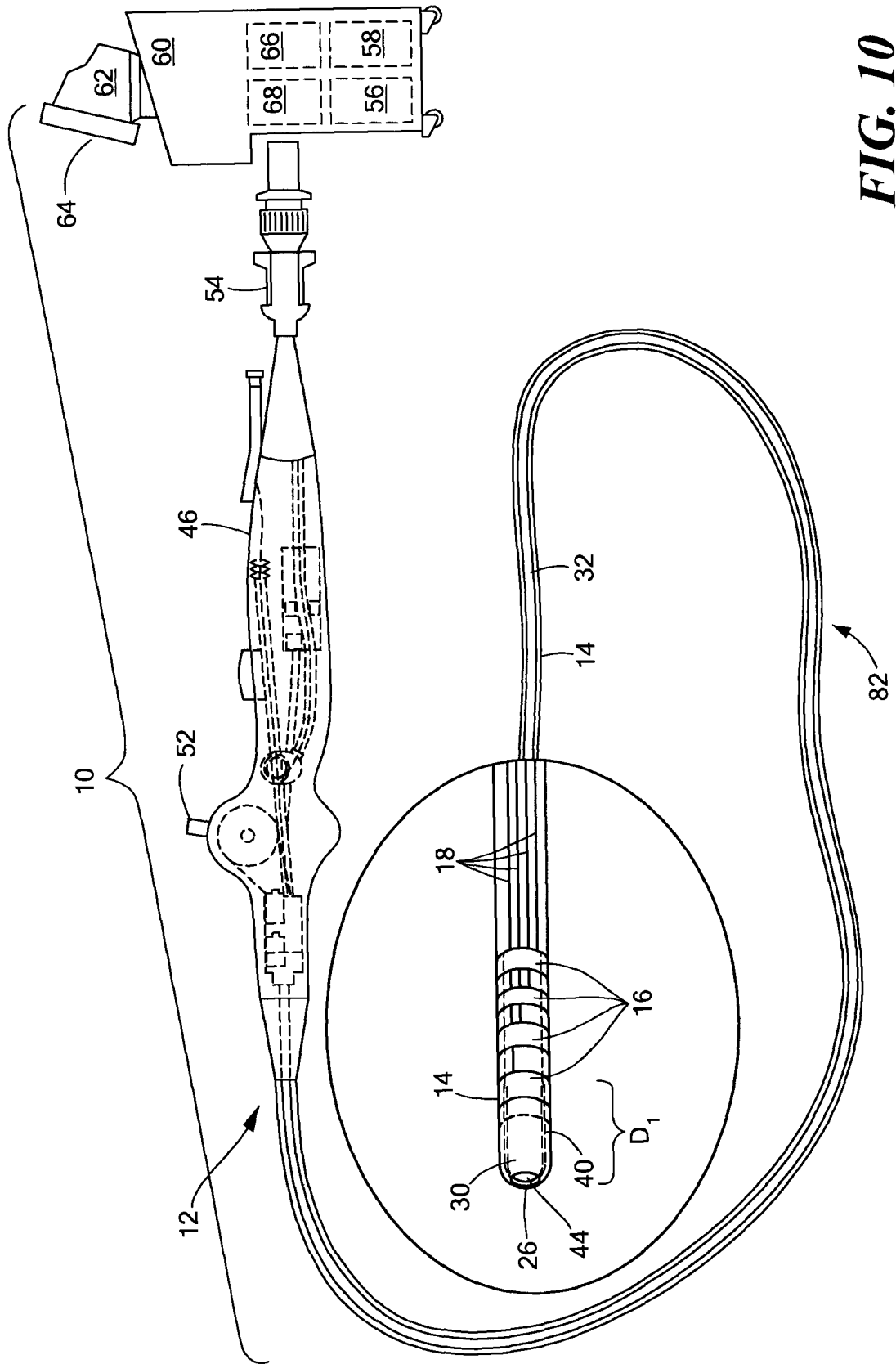
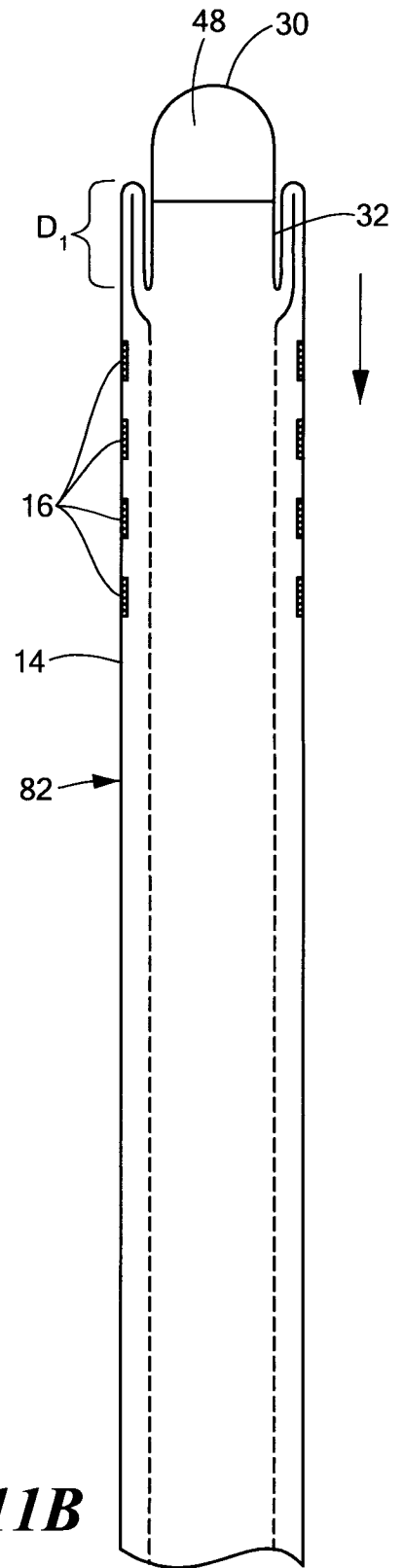
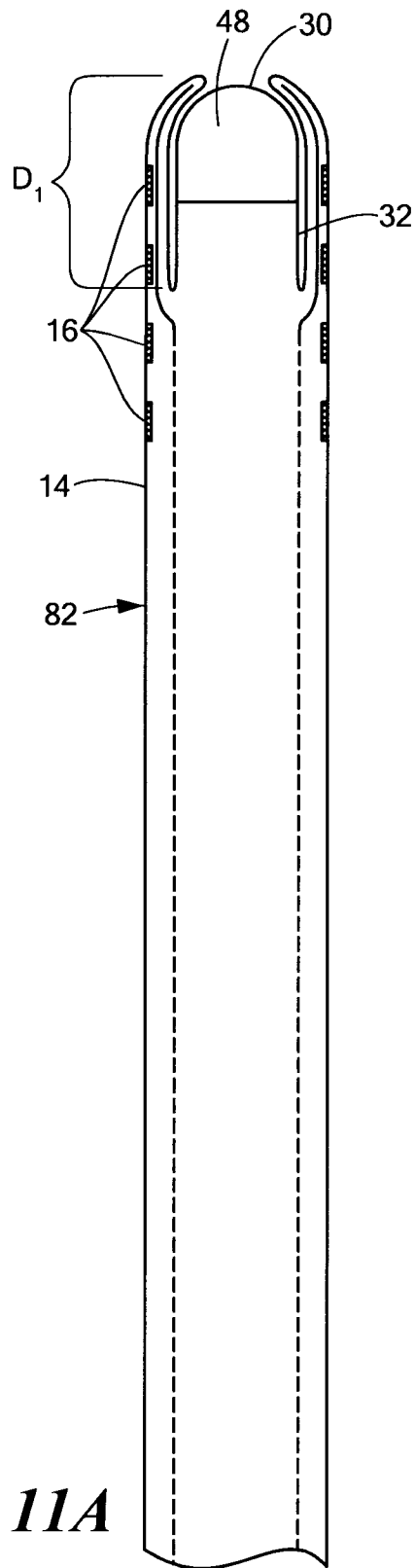

FIG. 10



INTERNATIONAL SEARCH REPORT

International application No.

PCT/CA2014/000010

A. CLASSIFICATION OF SUBJECT MATTER
 IPC: *A61B 5/00* (2006.01), *A61B 18/14* (2006.01), *A61B 5/0408* (2006.01)

According to International Patent Classification (IPC) or to both national classification and IPC

B. FIELDS SEARCHED IPC: *A61B 5/00* (2006.01), *A61B 18/14* (2006.01), *A61B 5/0408* (2006.01)

Minimum documentation searched (classification system followed by classification symbols)

Documentation searched other than minimum documentation to the extent that such documents are included in the fields searched

Electronic database(s) consulted during the international search (name of database(s) and, where practicable, search terms used)
 Keywords: ablation, mapping, combination, device, electrodes, resilient, sleeve, target, tissue, accessory, medical
 Databases: CPD (Canadian Patent Database), Total Patent, Google Patents, IEEE Xplore

C. DOCUMENTS CONSIDERED TO BE RELEVANT

Category*	Citation of document, with indication, where appropriate, of the relevant passages	Relevant to claim No.
X	US8114069 (B2) 14 Feb. 2012 (14-02-2012) by Sliwa Jr ** see abstract, entire document**	1-15
X	US7824403 (B2) 2 Nov. 2010 (02-11-2010) by Vasks ** see abstract, entire document**	1-15
X	US6858026 (B2) 22 Feb. 2005(22-02-2005) by Sliwa Jr. ** see abstract, entire document**	1-15

 Further documents are listed in the continuation of Box C.

 See patent family annex.

* "A" "E" "L" "O" "P"	Special categories of cited documents: document defining the general state of the art which is not considered to be of particular relevance earlier application or patent but published on or after the international filing date document which may throw doubts on priority claim(s) or which is cited to establish the publication date of another citation or other special reason (as specified) document referring to an oral disclosure, use, exhibition or other means document published prior to the international filing date but later than the priority date claimed	"T" "X" "Y" "&"	later document published after the international filing date or priority date and not in conflict with the application but cited to understand the principle or theory underlying the invention document of particular relevance; the claimed invention cannot be considered novel or cannot be considered to involve an inventive step when the document is taken alone document of particular relevance; the claimed invention cannot be considered to involve an inventive step when the document is combined with one or more other such documents, such combination being obvious to a person skilled in the art document member of the same patent family
--------------------------------------	---	--------------------------	--

Date of the actual completion of the international search
18 March 2014 (18-03-2004)

Date of mailing of the international search report
08 April 2014 (08-04-2014)

Name and mailing address of the ISA/CA
 Canadian Intellectual Property Office
 Place du Portage I, C114 - 1st Floor, Box PCT
 50 Victoria Street
 Gatineau, Quebec K1A 0C9
 Facsimile No.: 001-819-953-2476

Authorized officer
 Karen Oprea (819) 934-2668

INTERNATIONAL SEARCH REPORT
Information on patent family members

International application No.

PCT/CA2014/000010

Patent Document Cited in Search Report	Publication Date	Patent Family Member(s)	Publication Date
US8114069B2	14 February 2012 (14-02-2012)	US2006135954A1	22 June 2006 (22-06-2006)
		AT226840T	15 November 2002 (15-11-2002)
		AT261329T	15 March 2004 (15-03-2004)
		AT269742T	15 July 2004 (15-07-2004)
		AT277556T	15 October 2004 (15-10-2004)
		AT479462T	15 September 2010 (15-09-2010)
		AU668690B2	16 May 1996 (16-05-1996)
		AU771979A	10 April 1995 (10-04-1995)
		AU685161B2	15 January 1998 (15-01-1998)
		AU687232B2	19 February 1998 (19-02-1998)
		AU6024594A	14 September 1994 (14-09-1994)
		AU688303B2	12 March 1998 (12-03-1998)
		AU1433295A	17 July 1995 (17-07-1995)
		AU691236B2	14 May 1998 (14-05-1998)
		AU1175995A	19 June 1995 (19-06-1995)
		AU691854B2	28 May 1998 (28-05-1998)
		AU691893B2	28 May 1998 (28-05-1998)
		AU4284796A	26 June 1996 (26-06-1996)
		AU696812B2	17 September 1998 (17-09-1998)
		AU1099595A	27 June 1995 (27-06-1995)
		AU702940B2	11 March 1999 (11-03-1999)
		AU708976B2	19 August 1999 (19-08-1999)
		AU4469096A	31 July 1996 (31-07-1996)
		AU709259B2	26 August 1999 (26-08-1999)
		AU719765B2	18 May 2000 (18-05-2000)
		AU723379B2	24 August 2000 (24-08-2000)
		AU740743B2	15 November 2001 (15-11-2001)
		AU761079B2	29 May 2003 (29-05-2003)
		AU767608B2	20 November 2003 (20-11-2003)
		AU773823B2	10 June 2004 (10-06-2004)
		AU773823C	03 February 2005 (03-02-2005)
		AU775394B2	29 July 2004 (29-07-2004)
		AU1087497A	27 June 1997 (27-06-1997)
		AU1296197A	03 July 1997 (03-07-1997)
		AU1564802A	11 April 2002 (11-04-2002)
		AU1582497A	22 August 1997 (22-08-1997)
		AU1749897A	11 August 1997 (11-08-1997)
		AU1805499A	28 June 1999 (28-06-1999)
		AU1980895A	03 October 1995 (03-10-1995)
		AU2071097A	22 September 1997 (22-09-1997)
		AU2412792A	23 February 1993 (23-02-1993)
		AU2777495A	19 January 1996 (19-01-1996)
		AU3214895A	14 March 1996 (14-03-1996)
		AU3394397A	07 January 1998 (07-01-1998)
		AU3737397A	10 February 1998 (10-02-1998)
AU4272800A	07 September 2000 (07-09-2000)		
AU5003197A	15 May 1998 (15-05-1998)		
AU5188596A	16 October 1996 (16-10-1996)		
AU5189496A	16 October 1996 (16-10-1996)		
AU5308996A	07 November 1996 (07-11-1996)		
AU5781401A	07 February 2002 (07-02-2002)		
AU5951996A	30 December 1996 (30-12-1996)		
AU5956596A	30 December 1996 (30-12-1996)		
AU5962196A	30 December 1996 (30-12-1996)		
AU6154199A	10 April 2000 (10-04-2000)		
AU6354200A	05 February 2001 (05-02-2001)		
AU8613098A	23 March 2000 (23-03-2000)		
AU2002315167B2	08 November 2000(08-11-2007)		
AU2003275243A1	19 April 2004 (19-04-2004)		
AU2003275243B2	02 April 2009 (02-04-2009)		
AU2003275243C1	21 January 2010 (21-01-2010)		
AU2004205242A1	23 September 2004 (23-09-2004)		
AU2004205242B2	08 November 2007 (08-11-2007)		

INTERNATIONAL SEARCH REPORT

International application No.

PCT/CA2014/000010

AU2004205242B2	08 November 2007 (08-11-2007)
CA2113476A1	04 February 1993 (04-02-1993)
CA2113476C	10 October 2006 (10-10-2006)
CA2154354A1	01 September 1994 (01-09-1994)
CA2171097A1	30 March 1995 (30-03-1995)
CA2177490A1	15 June 1995 (15-06-1995)
CA2177490C	27 June 2006 (27-06-2006)
CA2177491A1	08 June 1995 (08-06-1995)
CA2179897A1	06 July 1995 (06-07-1995)
CA2185093A1	21 September 1995 (21-09-1995)
CA2198127A1	29 February 1996 (29-02-1996)
CA2206091A1	13 June 1996 (13-06-1996)
CA2208350A1	18 July 1996 (18-07-1996)
CA2215970A1	03 October 1996 (03-10-1996)
CA2218105A1	03 October 1996 (03-10-1996)
CA2218545A1	24 October 1996 (24-10-1996)
CA2218545C	11 September 2012 (11-09-2012)
CA2222218A1	19 December 1996 (19-12-1996)
CA2222326A1	19 December 1996 (19-12-1996)
CA2222326C	15 August 2006 (15-08-2006)
CA2239907A1	19 December 1996 (19-12-1996)
CA2249064A1	12 September 1997 (12-09-1997)
CA2253315A1	24 December 1997 (24-12-1997)
CA2354677A1	05 February 2002 (05-02-2002)
CA2377583A1	25 January 2001 (25-01-2001)
CA2450075A1	27 December 2002 (27-12-2002)
CA2450075C	19 November 2013 (19-11-2013)
CA2499223A1	08 April 2004 (08-04-2004)
CA2499223C	18 June 2013 (18-06-2013)
DE69230375D1	05 January 2000 (05-01-2000)
DE69230375T2	06 July 2000 (06-07-2000)
DE69233210D1	23 October 2003 (23-10-2003)
DE69233210T2	19 August 2004 (19-08-2004)
DE69233715D1	27 December 2007 (27-12-2007)
DE69233715T2	30 October 2008 (30-10-2008)
DE69430382D1	16 May 2002 (16-05-2002)
DE69430382T2	12 December 2002 (12-12-2002)
DE69430433D1	23 May 2002 (23-05-2002)
DE69430433T2	12 December 2002 (12-12-2002)
DE69431872D1	23 January 2003 (23-01-2003)
DE69431872T2	18 September 2003 (18-09-2003)
DE69434040D1	04 November 2004 (04-11-2004)
DE69434040T2	06 October 2005 (06-10-2005)
DE69435281D1	22 April 2010 (22-04-2010)
DE69435312D1	14 October 2010 (14-10-2010)
DE69528712D1	05 December 2002 (05-12-2002)
DE69528712T2	03 April 2003 (03-04-2003)
DE69532686D1	15 April 2004 (15-04-2004)
DE69532686T2	10 February 2005 (10-02-2005)
DE69626105D1	13 March 2003 (13-03-2003)
DE69626105T2	23 October 2003 (23-10-2003)
DE69626822D1	24 April 2003 (24-04-2003)
DE69626822T2	04 March 2004 (04-03-2004)
DE69632776D1	29 July 2004 (29-07-2004)
DE69632776T2	25 August 2005 (25-08-2005)
DE69738378D1	24 January 2008 (24-01-2008)
DE69738378T2	27 November 2008 (27-11-2008)
DE69739942D1	02 September 2010 (02-09-2010)
DE69942614D1	02 September 2010 (02-09-2010)
EP0597967A1	25 May 1994 (25-05-1994)
EP0597967A4	07 December 1994 (07-12-1994)
EP0597967B1	01 December 1999 (01-12-1999)
EP0684781A1	06 December 1995 (06-12-1995)
EP0684781A4	18 September 1996 (18-09-1996)
EP0684781B1	11 December 2002 (11-12-2002)

INTERNATIONAL SEARCH REPORT

International application No.

PCT/CA2014/000010

EP1647229A2

19 April 2006 (19-04-2006)

EP1647229A3	26 April 2006 (26-04-2006)
EP1864619A2	12 December 2007 (12-12-2007)
EP1864619A3	13 August 2008 (13-08-2008)
EP1864619B1	21 July 2010 (21-07-2010)
EP1980200A2	15 October 2008 (15-10-2008)
EP1980200A3	08 December 2010 (08-12-2010)
ES2142829T3	01 May 2000 (01-05-2000)
ES2207885T3	01 June 2004 (01-06-2004)
ES2217288T3	01 November 2004 (01-11-2004)
ES2229229T3	16 April 2005 (16-04-2005)
ES2296854T3	01 May 2008 (01-05-2008)
JPH09509074A	16 September 1997 (16-09-1997)
JP3618754B2	09 February 2005 (09-02-2005)
JPH10510178A	06 October 1998 (06-10-1998)
JP3650122B2	18 May 2005 (18-05-2005)
JPH09509585A	30 September 1997 (30-09-1997)
JP3717929B2	16 November 2005 (16-11-2005)
JP2001518808A	16 October 2001 (16-10-2001)
JP3992734B2	17 October 2007 (17-10-2007)
JPH06511167A	15 December 1994 (15-12-1994)
JPH08511694A	10 December 1996 (10-12-1996)
JPH09502889A	25 March 1997 (25-03-1997)
JPH09510117A	14 October 1997 (14-10-1997)
JPH10500587A	20 January 1998 (20-01-1998)
JPH10507653A	28 July 1998 (28-07-1998)
JPH10512163A	24 November 1998 (24-11-1998)
JPH11503646A	30 March 1999 (30-03-1999)
JP2000506051A	23 May 2000 (23-05-2000)
JP2000512874A	03 October 2000 (03-10-2000)
JP2002113009A	16 April 2002 (16-04-2002)
USRE35352E	15 October 1996 (15-10-1996)
US5370685A	06 December 1994 (06-12-1994)
US5425705A	20 June 1995 (20-06-1995)
US5433700A	18 July 1995 (18-07-1995)
US5452733A	26 September 1995 (26-09-1995)
US5458574A	17 October 1995 (17-10-1995)
US5536251A	16 July 1996 (16-07-1996)
US5545214A	13 August 1996 (13-08-1996)
US5558644A	24 September 1996 (24-09-1996)
US5569274A	29 October 1996 (29-10-1996)
US5571215A	05 November 1996 (05-11-1996)
US5584803A	17 December 1996 (17-12-1996)
US5613937A	25 March 1997 (25-03-1997)
US5618307A	08 April 1997 (08-04-1997)
US5626607A	06 May 1997 (06-05-1997)
US5682906A	04 November 1997 (04-11-1997)
US5695457A	09 December 1997 (09-12-1997)
US5702368A	30 December 1997 (30-12-1997)
US5713951A	03 February 1998 (03-02-1998)
US5718725A	17 February 1998 (17-02-1998)
US5725496A	10 March 1998 (10-03-1998)
US5728151A	17 March 1998 (17-03-1998)
US5735290A	07 April 1998 (07-04-1998)
US5738652A	14 April 1998 (14-04-1998)
US5759170A	02 June 1998 (02-06-1998)
US5762624A	09 June 1998 (09-06-1998)
US5766151A	16 June 1998 (16-06-1998)
US5769812A	23 June 1998 (23-06-1998)
US5792094A	11 August 1998 (11-08-1998)
US5795325A	18 August 1998 (18-08-1998)
US5797960A	25 August 1998 (25-08-1998)
US5799661A	01 September 1998 (01-09-1998)
US5807318A	15 September 1998 (15-09-1998)

INTERNATIONAL SEARCH REPORT

International application No.

PCT/CA2014/000010

US5814016A	29 September 1998 (29-09-1998)
US5814097A	29 September 1998 (29-09-1998)
US5823956A	20 October 1998 (20-10-1998)
US5829447A	03 November 1998 (03-11-1998)
US5849005A	15 December 1998 (15-12-1998)
US5855210A	05 January 1999 (05-01-1999)
US5855590A	05 January 1999 (05-01-1999)
US5855614A	05 January 1999 (05-01-1999)
US5863366A	26 January 1999 (26-01-1999)
US5868702A	09 February 1999 (09-02-1999)
US5879499A	09 March 1999 (09-03-1999)
US5885238A	23 March 1999 (23-03-1999)
US5913842A	22 June 1999 (22-06-1999)
US5916193A	29 June 1999 (29-06-1999)
US5924424A	20 July 1999 (20-07-1999)
US5961481A	05 October 1999 (05-10-1999)
US5971973A	26 October 1999 (26-10-1999)
US5972030A	26 October 1999 (26-10-1999)
US5980455A	09 November 1999 (09-11-1999)
US6010531A	04 January 2000 (04-01-2000)
US6027476A	22 February 2000 (22-02-2000)
US6029671A	29 February 2000 (29-02-2000)
US6079414A	27 June 2000 (27-06-2000)
US6125852A	03 October 2000 (03-10-2000)
US6152141A	28 November 2000 (28-11-2000)
US6161543A	19 December 2000 (19-12-2000)
US6237605B1	29 May 2001 (29-05-2001)
US6251093B1	26 June 2001 (26-06-2001)
US6283127B1	04 September 2001 (04-09-2001)
US6309382B1	30 October 2001 (30-10-2001)
US6311692B1	06 November 2001 (06-11-2001)
US6311693B1	06 November 2001 (06-11-2001)
US6314962B1	13 November 2001 (13-11-2001)
US6314963B1	13 November 2001 (13-11-2001)
US6325067B1	04 December 2001 (04-12-2001)
US6338735B1	15 January 2002 (15-01-2002)
US6346074B1	12 February 2002 (12-02-2002)
US2001016750A1	23 August 2001 (23-08-2001)
US6368340B2	09 April 2002 (09-04-2002)
US6401720B1	11 June 2002 (11-06-2002)
US6451004B1	17 September 2002 (17-09-2002)
US6451054B1	17 September 2002 (17-09-2002)
US6474340B1	05 November 2002 (05-11-2002)
US6478029B1	12 November 2002 (12-11-2002)
US6482171B1	19 November 2002 (19-11-2002)
US6484727B1	26 November 2002 (26-11-2002)
US6494211B1	17 December 2002 (17-12-2002)
US2002023653A1	28 February 2002 (28-02-2002)
US6494897B2	17 December 2002 (17-12-2002)
US6558318B1	06 May 2003 (06-05-2003)
US2002183839A1	05 December 2002 (05-12-2002)
US6564805B2	20 May 2003 (20-05-2003)
US2003040736A1	27 February 2003 (27-02-2003)
US6579259B2	17 June 2003 (17-06-2003)
US2002087183A1	04 July 2002 (04-07-2002)
US6613069B2	02 September 2003 (02-09-2003)
US2002022848A1	21 February 2002 (21-02-2002)
US6645197B2	11 November 2003 (11-11-2003)
US6645202B1	11 November 2003 (11-11-2003)
US6651671B1	25 November 2003 (25-11-2003)

INTERNATIONAL SEARCH REPORT

International application No.

PCT/CA2014/000010

US6840936B2

11 January 2005 (11-01-2005)

US2002042611A1 11 April 2002 (11-04-2002)
 US6858026B2 22 February 2005 (22-02-2005)
 US2001044591A1 22 November 2001 (22-11-2001)
 US6866650B2 15 March 2005 (15-03-2005)
 US2003145865A1 07 August 2003 (07-08-2003)
 US6899704B2 31 May 2005 (31-05-2005)
 US2001016725A1 23 August 2001 (23-08-2001)
 US6913600B2 05 July 2005 (05-07-2005)
 US2001023334A1 20 September 2001 (20-09-2001)
 US6913601B2 05 July 2005 (05-07-2005)
 US2003069577A1 10 April 2003 (10-04-2003)
 US6929010B2 16 August 2005 (16-08-2005)
 US2003079753A1 01 May 2003 (01-05-2003)
 US6949095B2 27 September 2005 (27-09-2005)
 US2003225402A1 04 December 2003 (04-12-2003)
 US6955175B2 18 October 2005 (18-10-2005)
 US2003073992A1 17 April 2003 (17-04-2003)
 US6971394B2 06 December 2005 (06-12-2005)
 US2002092533A1 18 July 2002 (18-07-2002)
 US7017581B2 28 March 2006 (28-03-2006)
 US2002013569A1 31 January 2002 (31-01-2002)
 US7028692B2 18 April 2006 (18-04-2006)
 US2004054363A1 18 March 2004 (18-03-2004)
 US7052493B2 30 May 2006 (30-05-2006)
 US2002100485A1 01 August 2002 (01-08-2002)
 US7100614B2 05 September 2006 (05-09-2006)
 US2004194791A1 07 October 2004 (07-10-2004)
 US7131447B2 07 November 2006 (07-11-2006)
 US2004055608A1 25 March 2004 (25-03-2004)
 US7213601B2 08 May 2007 (08-05-2007)
 US2003078571A1 24 April 2003 (24-04-2003)
 US7338486B2 04 March 2008 (04-03-2008)
 US2004106918A1 03 June 2004 (03-06-2004)
 US7387126B2 17 June 2008 (17-06-2008)
 US2008045935A1 21 February 2008 (21-02-2008)
 US7517345B2 14 April 2009 (14-04-2009)
 US2005033274A1 10 February 2005 (10-02-2005)
 US7674257B2 09 March 2010 (09-03-2010)
 US2006200119A1 07 September 2006 (07-09-2006)
 US7824402B2 02 November 2010 (02-11-2010)
 US2006184167A1 17 August 2006 (17-08-2006)
 US7824403B2 02 November 2010 (02-11-2010)
 US2007066974A1 22 March 2007 (22-03-2007)
 US2009192506A9 30 July 2009 (30-07-2009)
 US7857811B2 28 December 2010 (28-12-2010)
 US2006052802A1 09 March 2006 (09-03-2006)
 US7967833B2 28 June 2011 (28-06-2011)
 US2007191714A1 16 August 2007 (16-08-2007)
 US8002771B2 23 August 2011 (23-08-2011)
 US2007255276A1 01 November 2007 (01-11-2007)
 US8057465B2 15 November 2011 (15-11-2011)
 US2009171335A1 02 July 2009 (02-07-2009)
 US8177780B2 15 May 2012 (15-05-2012)
 US2007293854A1 20 December 2007 (20-12-2007)
 US8211096B2 03 July 2012 (03-07-2012)
 US2008091195A1 17 April 2008 (17-04-2008)
 US8308719B2 13 November 2012 (13-11-2012)
 US2012226269A1 06 September 2012 (06-09-2012)
 US8535301B2 17 September 2013 (17-09-2013)
 US2001001812A1 24 May 2001 (24-05-2001)
 US2001010247A1 02 August 2001 (02-08-2001)
 US2002017306A1 14 February 2002 (14-02-2002)
 US2002029783A1 14 March 2002 (14-03-2002)
 US2002056460A1 16 May 2002 (16-05-2002)
 US2002058995A1 16 May 2002 (16-05-2002)

INTERNATIONAL SEARCH REPORT

International application No.

PCT/CA2014/000010

US2011270388A9	03 November 2011 (03-11-2011)
US2002062065A1	23 May 2002 (23-05-2002)
US2002062066A1	23 May 2002 (23-05-2002)
US2002068855A1	06 June 2002 (06-06-2002)
US2002068922A1	06 June 2002 (06-06-2002)
US2002068970A1	06 June 2002 (06-06-2002)
US2002069884A1	13 June 2002 (13-06-2002)
US2002074004A1	20 June 2002 (20-06-2002)
US2002087157A1	04 July 2002 (04-07-2002)
US2002100482A1	01 August 2002 (01-08-2002)
US2002128639A1	12 September 2002 (12-09-2002)
US2003024537A1	06 February 2003 (06-02-2003)
US2003028187A1	06 February 2003 (06-02-2003)
US2003029462A1	13 February 2003 (13-02-2003)
US2003069574A1	10 April 2003 (10-04-2003)
US2004019348A1	29 January 2004 (29-01-2004)
US2004073301A1	15 April 2004 (15-04-2004)
US2004117032A1	17 June 2004 (17-06-2004)
US2004225355A1	11 November 2004 (11-11-2004)
US2004236418A1	25 November 2004 (25-11-2004)
US2004260278A1	23 December 2004 (23-12-2004)
US2005148997A1	07 July 2005 (07-07-2005)
US2005245918A1	03 November 2005 (03-11-2005)
US2005251125A1	10 November 2005 (10-11-2005)
US2006004352A1	05 January 2006 (05-01-2006)
US2006058775A1	16 March 2006 (16-03-2006)
US2007282324A1	06 December 2007 (06-12-2007)
US2007293855A1	20 December 2007 (20-12-2007)
US2008029105A1	07 February 2008 (07-02-2008)
US2008045936A1	21 February 2008 (21-02-2008)
US2008045946A1	21 February 2008 (21-02-2008)
US2008183168A1	31 July 2008 (31-07-2008)
US2012271334A1	25 October 2012 (25-10-2012)
WO0016850A1	30 March 2000 (30-03-2000)
WO0016850A9	26 October 2000 (26-10-2000)
WO0105306A1	25 January 2001 (25-01-2001)
WO9301768A1	04 February 1993 (04-02-1993)
WO9418881A1	01 September 1994 (01-09-1994)
WO9508364A1	30 March 1995 (30-03-1995)
WO9515192A1	08 June 1995 (08-06-1995)
WO9515715A1	15 June 1995 (15-06-1995)
WO9517919A1	06 July 1995 (06-07-1995)
WO9524940A1	21 September 1995 (21-09-1995)
WO9600033A1	04 January 1996 (04-01-1996)
WO9605773A1	29 February 1996 (29-02-1996)
WO9617644A1	13 June 1996 (13-06-1996)
WO9621489A1	18 July 1996 (18-07-1996)
WO9630072A1	03 October 1996 (03-10-1996)
WO9630073A1	03 October 1996 (03-10-1996)
WO9632882A1	24 October 1996 (24-10-1996)
WO9639942A1	19 December 1996 (19-12-1996)
WO9640347A1	19 December 1996 (19-12-1996)
WO9640354A1	19 December 1996 (19-12-1996)
WO9720506A1	12 June 1997 (12-06-1997)
WO9721462A1	19 June 1997 (19-06-1997)
WO9726034A1	24 July 1997 (24-07-1997)
WO9727799A1	07 August 1997 (07-08-1997)
WO9732623A1	12 September 1997 (12-09-1997)
WO9748434A1	24 December 1997 (24-12-1997)
WO9929251A1	17 June 1999 (17-06-1999)
WO02102231A2	27 December 2002 (27-12-2002)
WO02102231A3	15 May 2003 (15-05-2003)
WO2004028233A2	08 April 2004 (08-04-2004)
WO2004028233A3	24 June 2004 (24-06-2004)

NOTE **D1 to D3 are equivalent documents sharing identical family members**