

(19) World Intellectual Property Organization
International Bureau



(43) International Publication Date
12 November 2009 (12.11.2009)

PCT

(10) International Publication Number
WO 2009/137828 A1

(51) International Patent Classification:
G01S 15/00 (2006.01) *G01F 1/00* (2006.01)

(21) International Application Number:
PCT/US2009/043438

(22) International Filing Date:
11 May 2009 (11.05.2009)

(25) Filing Language: English

(26) Publication Language: English

(30) Priority Data:
61/051,775 9 May 2008 (09.05.2008) US
61/051,791 9 May 2008 (09.05.2008) US
61/051,803 9 May 2008 (09.05.2008) US

(71) Applicant (for all designated States except US): **CIDRA CORPORATE SERVICES, INC.** [US/US]; 50 Barnes Park North, Wallingford, CT 06492 (US).

(72) Inventors; and

(75) Inventors/Applicants (for US only): **ROTHMAN, Paul, J.** [US/US]; 162 Carriage Way, Windsor, CT 06095 (US). **MARON, Robert, J.** [US/US]; 1 Mohawk Court, Cromwell, CT 06416 (US). **O'KEEFE, Christian, Victor** [US/US]; 58 Canterbury Drive, Durham, CT 06422 (US).

(74) Agent: **BARBER, William, J.**; Ware, Fressola, Van Der Sluys & Adolphson LLP, 755 Main Street, P.O. Box 224, Monroe, CT 06468 (US).

(81) Designated States (unless otherwise indicated, for every kind of national protection available): AE, AG, AL, AM, AO, AT, AU, AZ, BA, BB, BG, BH, BR, BW, BY, BZ, CA, CH, CN, CO, CR, CU, CZ, DE, DK, DM, DO, DZ, EC, EE, EG, ES, FI, GB, GD, GE, GH, GM, GT, HN, HR, HU, ID, IL, IN, IS, JP, KE, KG, KM, KN, KP, KR, KZ, LA, LC, LK, LR, LS, LT, LU, LY, MA, MD, ME, MG, MK, MN, MW, MX, MY, MZ, NA, NG, NI, NO, NZ, OM, PG, PH, PL, PT, RO, RS, RU, SC, SD, SE, SG, SK, SL, SM, ST, SV, SY, TJ, TM, TN, TR, TT, TZ, UA, UG, US, UZ, VC, VN, ZA, ZM, ZW.

(84) Designated States (unless otherwise indicated, for every kind of regional protection available): ARIPO (BW, GH, GM, KE, LS, MW, MZ, NA, SD, SL, SZ, TZ, UG, ZM, ZW), Eurasian (AM, AZ, BY, KG, KZ, MD, RU, TJ, TM), European (AT, BE, BG, CH, CY, CZ, DE, DK, EE, ES, FI, FR, GB, GR, HR, HU, IE, IS, IT, LT, LU, LV, MC, MK, MT, NL, NO, PL, PT, RO, SE, SI, SK, TR), OAPI (BF, BJ, CF, CG, CI, CM, GA, GN, GQ, GW, ML, MR, NE, SN, TD, TG).

Published:

— with international search report (Art. 21(3))

(54) Title: APPLICATIONS OF SONAR-BASED VF/GVF METERING TO INDUSTRIAL PROCESSING

FIGURE 2: Grinding Stage

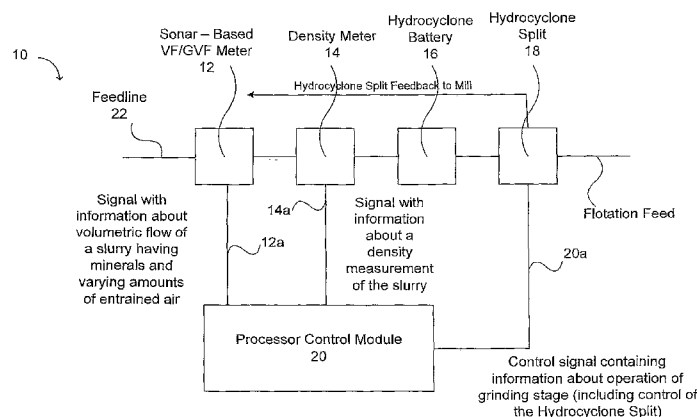

(57) Abstract: The present invention provides a new and unique processor module that features one or more modules configured to respond to one or more input signals containing information about a volumetric flow of a fluid having minerals and varying amounts of entrained gas flowing in a pipe and being processed in a processing stage of a mineral extraction processing system for extracting a mineral from ore, and also configured to provide one or more output signals containing information about operations of the processing stage of the mineral extraction processing system that is not substantially affected by the varying amounts of entrained gas in the fluid flowing in the pipe. The one or more output signals may be used to control the operations of the processing stage. The one or more input signals may be based at least partly on a speed of sound measurement, including a SONAR-based entrained gas measurement to determine the amount of entrained air in conjunction with a density measurement of the fluid flowing in the pipe.



WO 2009/137828 A1

and ore, to which chemicals are added prior to being sent to the flotation stage. Once in the flotation stage, air is used to float the copper mineral while the gangue (tailings) is depressed. The recovered copper is cleaned and dried. The tailings are thickened and sent to the tailings pond. The classification stage is critical to the performance of two areas of the process. These areas are the grinding throughput and flotation recovery, grade and throughput.

Grinding Operation

A grinding operation may include a screens and crusher stage and a mill stage shown in Figure 1c, that is typically configured mills in closed circuit with a hydrocyclone battery. A hydrocyclone is a mechanical device that will separate a slurry stream whereby the smaller particles will exit out the overflow line and the larger particles will exit out the underflow line. The overflow is sent to the flotation circuit and the underflow is sent back to the mill for further grinding. A collection of these devices is called a battery. A hydrocyclone will be sized based on the particular process requirements. The performance of the hydrocyclone is dependent on how well it is matched to the process conditions. Once the proper hydrocyclone has been chosen and installed, it must be operated within a specific range in order to maintain the proper split between the overflow and the underflow. The split is dependent on slurry feed density and volumetric flow into the device. A typical control system will use a combination of volumetric flow, feed density and pressure across the hydrocyclone to control the split. Because of the harsh environmental and process conditions all of these

measurements suffer from maintenance and performance issues. This can result in reduced classification performance and reduced mill throughput. Flotation performance is highly dependent on the particle size distribution in the feed which comes from the battery overflow, thus it is dependent on the hydrocyclone classification performance. The mill throughput is highly dependent on the circulation load which comes from the battery underflow.

The process conditions are challenging because the slurry is made up of high solids content slurry which contains varying amounts of entrained air. The air is entrained by the pumping action needed to transport the slurry throughout the process. In the case of the feed to a hydrocyclone battery the slurry is collected in a sump before it is pumped to the battery. Often the sump levels drop below the desired level and air is pulled into the stream. Once the air is in the stream it is difficult to get out because the slurry is made up of a high solids content of small particles.

Making an accurate and repeatable volumetric flow and density measurement of a slurry, which has a varying amount of entrained air, is a challenging endeavor. The traditional in-line volumetric flow meter may display erratic readings in the presence of entrained air. It may also report a volumetric flow reading that is in error. The error will be a function of the amount of entrained air in the process. The same can be said for a density meter. The density meter will report the average density of the slurry air mixture as it passes by a sensor. What is desired is the density of the slurry alone. Therefore this

reported density reading will typically have an error which will be a function of the amount of entrained air in the process.

The traditional or known means of measuring volumetric flow and density have been subject to errors due to the presence of air in the process. This has
5 proven to make it difficult to control the split from the hydrocyclone battery which can impact the performance of both the milling and flotation circuits.

In view of the aforementioned, there is a long felt need in the industry to be able to correct errors in the density measurement due to the entrained air in such industrial processes, and to provide a more accurate and repeatable
10 hydrocyclone split based on the same.

Minerals Separation Process and Reagent Addition

In many industrial processes, a flotation process is used to concentrate
15 and clean the final product. The performance of the flotation process or stage is dependent on many parameters. One of those is the floatability of the ore. The floatability is highly dependent on the type and dose of chemical reagent that is used to make the particles hydrophobic. The chemical dosing rate is typically defined in units of grams of chemical per ton of ore processed. In some cases
20 more chemical is added than is necessary in order to make sure that enough is being used. These chemicals are very expensive and make up a sizable portion of a minerals processing plant's operational expenses.

In a typical plant, operators will determine the ore tonnage rate by using a weigh scale on the input ore feed to the first stage of grind. Then the reagent is

added according to the prescribed dosing rate. A more direct means of dosing the reagent would be to measure the actual mass flow of ore entering the flotation circuit. The reagent would be added based on this measurement not the weigh scale.

- 5 In view of the aforementioned, there is a long felt need in the industry to be able to correct errors in the density measurement due to the entrained air in such industrial processes, and to dose the reagent more accurately.

Final Product Accounting in an Industrial Process

- 10 In many minerals processing plants, or beneficiation plants, the ore is ground and concentrated to produce a product called final concentrate. In the case of the copper concentrator, the input to the plant is water and ore (of a particular type and size distribution) and the outputs are copper concentrate and tailings. The process consists of a grinding, classification, floatation, and
- 15 thickening. The grinding and classification stage produces fine slurry of water, ore, and chemicals which is then sent to the flotation stage. Once in the flotation stage air is used to float the copper mineral while the gange (tailings) is depressed. The recovered copper is cleaned and dried and is known as the final concentrate. The tailings are thickened and sent to the tailings pond.

- 20 Measuring the amount of concentrate, while in the slurry form, is a difficult task. The slurry is made up of high solids content. The solids are made up of small particles of high specific gravity. The combination of this type of slurry being transported via pumping systems and the injection of air at the flotation

stage makes this slurry become aerated. The slurry has varying amounts of entrained gas/air throughout the process.

This is an important measurement because in many cases it is the final accounting metric for the processing plant. In many plants, the concentrate may
5 be dried and weighed. Alternatively, in some cases instruments such as volumetric flow meters, density meters, and stream analyzers are used to make these measurements. In an ideal environment these instruments will provide accurate and repeatable data. Unfortunately, many industrial processes require these instruments to operate in very harsh environments. This includes both
10 extreme physical environmental conditions as well as challenging process conditions. Because of these practical realities the accuracy and repeatability of these instruments is often called into question. Therefore the final product accounting is called into question.

In view of the aforementioned, there is a long felt need in the industry to
15 be able to correct errors in the density measurement due to the entrained air in such industrial processes, and to provide a more accurate and repeatable final accounting.

SUMMARY OF THE INVENTION

20 The Application of SONAR
to a Classification Process to Improve Performance

The two critical measurements needed to control the hydrocyclone battery are volumetric flow and density. Therefore, in the prior art a traditional flow meter and density meter were placed on the feedline to the hydrocyclone battery.

Because of the limitations of traditional flow meters, pressure sensors are also often used as an indication of volumetric flow. By replacing the traditional flow meter (or pressure sensor) with a SONAR-based volumetric flow/gas volume fraction (VF/GVF) meter according to the present invention, a more accurate and repeatable measurement of volumetric flow may be achieved. The SONAR-based meter is not affected by the entrained air. In fact, the SONAR-based meter can measure the amount of entrained air. This will then be used to correct the errors in the density measurement due to the entrained air in the process. As a result a more accurate and repeatable hydrocyclone split may be achieved according to the present invention.

The Application of SONAR to a Minerals Separation Process
to Optimize Reagent Addition

In order to make a direct measurement of the mass flow of the ore entering the flotation circuit according to the present invention, a SONAR-based volumetric flow/gas volume fraction (VF/GVF) meter and a density meter is placed in the input line according to the present invention. The reagent may then be dosed based on the exact measured mass flow rate according to the present invention. The density meter may include a nuclear density gauge.

The Application of SONAR to an Industrial Process
to Improve Final Product Accounting

The two critical measurements for final product accounting are volumetric flow and density. Therefore, in the prior art the traditional flow meter and density

meter are typically placed at the end of the process. By replacing the traditional flow meter with a SONAR-based VF/GVF meter according to the present invention, a more accurate and repeatable measurement of volumetric flow may be achieved. The SONAR-based meter is not affected by the entrained air. In fact, the SONAR meter can measure the amount of entrained air. This will then be used to correct the errors in the density measurement due to the entrained air in the process. As a result a more accurate and repeatable final accounting may be achieved according to the present invention.

10 The Signal Processor Module

In its broadest sense, the present invention provides a new and unique method and apparatus that may be used in each of the aforementioned applications. According to some embodiments of the present invention, the apparatus may take the form of a processor module that features one or more modules configured to respond to one or more input signals containing information about a volumetric flow of a fluid having minerals and varying amounts of entrained gas flowing in a pipe and being processed in a processing stage of a mineral extraction processing system for extracting a mineral from ore, and also configured to provide one or more output signals containing information about operations of the processing stage of the mineral extraction processing system that is not substantially affected by the varying amounts of entrained gas in the fluid flowing in the pipe.

According to some embodiments of the present invention, the one or more output signals may be used to control the operations of the processing stage.

According to some embodiments of the present invention, the one or more input signals may be based at least partly on a speed of sound measurement, including a SONAR-based entrained gas measurement to determine the amount of entrained air in conjunction with a density measurement of the fluid flowing in the pipe.

According to some embodiments of the present invention, the one or more input signals may be received from a SONAR-based volumetric flow/gas volume fraction meter placed on a feed line pipe providing the fluid to the processing stage.

According to some embodiments of the present invention, the one or more input signals may be received from a SONAR-based volumetric flow/gas volume fraction meter placed on an output line pipe receiving the fluid from the processing stage.

According to some embodiments of the present invention, the one or more input signals may also be based at least partly on a gas volume measurement that depends on acoustic pressures sensed in the fluid flowing in the pipe.

According to some embodiments of the present invention, the one or more output signals may depend on an error correction based at least partly on the amount of entrained air in the fluid.

According to some embodiments of the present invention, the error correction may correct errors in a density measurement of the fluid.

According to some embodiments of the present invention, the fluid may take the form of a slurry made up of high solids which contain varying amounts of entrained air.

5 According to some embodiments of the present invention, the processing stage may form part of a mineral concentrator that is either now known or later developed in the future, as well as other mineral extractions processing systems either now known or later developed in the future.

10 According to some embodiments of the present invention, the method may take the form of steps for responding with one or more modules to one or more input signals containing information about a volumetric flow of a fluid having minerals and varying amounts of entrained gas flowing in a pipe and being processed in a processing stage of a mineral extraction processing system for extracting a mineral from ore; and providing with one or more modules one or more output signals containing information about operations of the processing
15 stage of the mineral extraction processing system that is not substantially affected by the varying amounts of entrained gas in the fluid flowing in the pipe.

20 According to some embodiments of the present invention, the apparatus may also take the form of a computer-readable storage medium having computer-executable components for performing the steps of the aforementioned method.

BRIEF DESCRIPTION OF THE DRAWING

The drawing includes Figures 1 - 4, which are not drawn to scale, as follows:

Figure 1a is a block diagram of a mineral extraction processing system in the form of a copper concentrator that is known in the art.

Figure 1b is a block diagram showing typical processing stages of a mineral extraction processing system that is known in the art.

Figure 1c is a block diagram showing a processing stage of a mineral extraction processing system in the form of a grinding stage that is known in the art.

Figure 2 is a block diagram showing a grinding stage according to some embodiment of the present invention.

Figures 3a-3c are block diagrams showing a flotation stage according to some embodiment of the present invention.

Figures 4 and 4a are block diagrams showing a post-flotation stage according to some embodiment of the present invention.

DETAILED DESCRIPTION OF BEST MODE OF THE INVENTION

Figure 2: The Grinding Stage

Figure 2 shows a grinding stage generally indicated as 10 that forms part of a mineral extraction processing system for extracting minerals from ore. The present invention as it relates to the grinding stage 10 is described in relation to the mineral extraction processing system taking the form of a copper

concentrator, although the scope of the invention is not intended to be limited to any particular type or kind of mineral process or mineral extraction processing system either now known or later developed in the future.

The grinding stage 10 includes a SONAR-based volumetric flow/gas
5 volume fraction (VF/GVF) meter 12, a density meter 14, a hydrocyclone or hydrocyclone battery 16, a hydrocyclone split 18 and a processor module (also known as a processor control module) 20.

The SONAR-based VF/GVF meter 12 is placed on a feedline pipe 22 in relation to the hydrocyclone battery 16. The feedline pipe 22 provides a slurry
10 having minerals and varying amounts of entrained air to the grinding stage 10. The SONAR-based VF/GVF meter 12 is configured to sense the volumetric flow of the slurry and provide a signal along line 12a containing information about the volumetric flow that is not substantially affected by the varying amounts of entrained air in the slurry. The SONAR-based VF/GVF meter 12 is known in the
15 art and may take the form of a SONAR-based VF/GVF-100 meter, and is disclosed by way of example in whole or in part in United States Patent Nos. 7,165,464; 7,134,320; 7,363,800; 7,367,240; and 7,343,820, all of which are incorporated by reference in their entirety. The scope of the invention is also intended to include other types or kinds of SONAR-based VF/GVF meters either
20 now known or later developed in the future that perform the same basic functionality of the SONAR-based VF/GVF meter 12 as such functionality relates to implementing the present invention.

The processor module 20 is configured to respond to the signal along line 12a from the SONAR-based VF/GVF meter 12, and also configured to provide an output signal along line 20a containing information to control the hydrocyclone split 18 that provides a flotation feed from the hydrocyclone battery 16. As shown, the hydrocyclone split 18 provides the flotation feed to the next stage in the mineral extraction processing system (see Figure 1b by way of example), and provides a hydrocyclone split feedback to the feedline pipe 22. In addition to controlling the split, the signal on line 20a can also be used to control other parameters either now known or later developed in the future, such as pump speed or the addition of dilution water. The scope of the invention is not intended to be limited to the type or kind of parameter, or the manner in which the parameter is being controlled.

The density meter 14 is placed on the feed line pipe in relation to the SONAR-based VF/GVF meter and is configured to provide a signal along line 14a containing information about a density measurement of the slurry to the processor module 20. The density meter 14 is known in the art, and disclosed by way of example in whole or in part in United States Patent Nos. 7,165,464; 7,134,320; 7,363,800; 7,367,240; and 7,343,820. The scope of the invention is also intended to include other types or kinds of meters like meter 14 either now known or later developed in the future that perform the same basic functionality of the meter 14 as such functionality relates to implementing the present invention. In operation, the SONAR-based VF/GVF meter 12 is configured to measure the amount of entrained air which may be used by the processor

module 20 to correct errors in the density measurement of the fluid, according to some embodiments of the present invention. For example, the processor module 20 may use the errors in the density measurement of the fluid to determine and provide the output signal along line 20a containing information to control the hydrocyclone split 18 according to the present invention. By way of example, and consistent with that discuss above, the technique for making this measurement and correction is disclosed in whole or in part in United States Patent Nos. 7,165,464; 7,134,320; 7,363,800; 7,367,240; and 7,343,820. Moreover, by way of example, the present invention is disclosed with the meter 12 being arranged in front of the density meter 14, although the scope of the invention is not intended to be limited to any particular arrangement of the meters.

The functionality of the processor module 20 may be implemented using hardware, software, firmware, or a combination thereof. In a typical software implementation, the processor modules would include one or more microprocessor-based architectures having a microprocessor, a random access memory (RAM), a read only memory (ROM), input/output devices and control, data and address buses connecting the same. A person skilled in the art would be able to program such a microprocessor-based implementation to perform the functionality described herein without undue experimentation. The scope of the invention is not intended to be limited to any particular implementation using technology either now known or later developed in the future.

The hydrocyclone battery 16 and the hydrocyclone split 18 are known in the art, and the scope of the invention is not intended to be limited to any particular type or kind thereof either now known or later developed in the future. As shown in Figure 2, the feedback line from the hydrocyclone split 18 is shown
5 going back to the mill stage (see Figure 1c) so the larger size particles can be re-ground. However, the scope of the invention is not intended to be limited to where this feedback is fed back to or processed.

The grinding stage 10 may also include one or more elements, devices, apparatus or equipment that are known in the art, do not form part of the
10 underlying invention, and are not disclosed herein or described in detail for that reason.

The scope of the invention re grinding stage and/or hydrocyclone applications is not intended to be limited to the type or kind of mineral being processed, or the type of mineral process, either now known or later developed
15 in the future. By way of example, the scope of the invention is intended to include hydrocyclone applications include Molybdenum, Lead, Zinc, Iron, Gold, Silver, Nickel, Fluorite, Tantalum, Tungsten, Tin, Lithium, Coal, as well as, e.g. diamonds, etc.

Figures 3a-3c: The Flotation Stage

20 Figure 3a shows a flotation stage generally indicated as 50 that forms part of a mineral extraction processing system for extracting minerals from ore. The present invention as it relates to the flotation stage 50 is described in relation to the mineral extraction processing system taking the form of a copper

concentrator, although the scope of the invention is not intended to be limited to any particular type or kind of mineral extraction processing system either now known or later developed in the future.

The flotation stage 50 includes a SONAR-based volumetric flow/gas
5 volume fraction (VF/GVF) meter 52, a density meter 54, a flotation system 56
and a processor module (also known as a processor control module) 58.

The SONAR-based VF/GVF meter 52 is placed on a feedline pipe 60 in
relation to the flotation system 56. The feedline pipe 60 provides a slurry having
minerals and varying amounts of entrained air to the flotation stage 50. The
10 SONAR-based VF/GVF meter 52 is configured to sense the volumetric flow of
the slurry and provide a signal along line 52a containing information about the
volumetric flow that is not substantially affected by the varying amounts of
entrained air in the slurry. According to some embodiments of the present
invention, the SONAR-based VF/GVF meter 52 is configured to make a direct
15 measurement of a mass flow of ore entering the flotation stage 50. The SONAR-
based VF/GVF meter 52 is known in the art, and disclosed by way of example in
whole or in part in the aforementioned United States Patent Nos. 7,165,464;
7,134,320; 7,363,800; 7,367,240; and 7,343,820. Consistent with that described
above, the scope of the invention is also intended to include other types or kinds
20 of SONAR-based VF/GVF meters either now known or later developed in the
future that perform the same basic functionality of the SONAR-based VF/GVF
meter 52 as such functionality relates to implementing the present invention.

The processor module 58 is configured to respond to the signal along line 52a from the SONAR-based VF/GVF meter 52, and also configured to provide an output signal along line 58a containing information to control a dosing of a reagent that is provided to the slurry in the flotation stage 50. In addition, the processor control module 58 could also provide a control signal to control feed rate and/or density, as well as to control other parameters either now known or later developed in the future. Consistent with that described above, the scope of the invention is not intended to be limited to the type or kind of parameter, or the manner in which the parameter is being controlled. According to some embodiments of the present invention, the reagent may be dosed based on a measured mass flow rate of the ore entering the flotation stage 50 by the SONAR-based VF/GVF meter 52. As shown, the flotation system 56 provides a flotation output slurry to the next stage in the mineral extraction processing system (see Figure 1b by way of example).

The density meter 54 is placed on the feed line pipe in relation to the SONAR-based VF/GVF meter 52 and is configured to provide a signal along line 54a containing information about a density measurement of the slurry to the processor module 20. Consistent with that described above, the density meter 54 is known in the art, and disclosed by way of example in whole or in part in United States Patent Nos. 7,165,464; 7,134,320; 7,363,800; 7,367,240; and 7,343,820. The scope of the invention is also intended to include other types or kinds of meters like meter 54 either now known or later developed in the future that perform the same basic functionality of the meter 54 as such functionality

relates to implementing the present invention. In operation, the SONAR-based VF/GVF meter 52 is configured to measure the amount of entrained air which may be used by the processor module 58 to correct errors in the density measurement of the fluid, according to some embodiments of the present invention. For example, the processor module 58 may use the errors in the density measurement of the fluid to determine and provide the output signal along line 58a containing information to control the dosing of the reagent that is provided to the slurry in the flotation stage 50, according to the present invention. By way of example, and consistent with that discuss above, the technique for making this measurement and correction is disclosed in whole or in part in United States Patent Nos. 7,165,464; 7,134,320; 7,363,800; 7,367,240; and 7,343,820. Moreover, by way of example, the present invention is disclosed with the meter 52 being arranged in front of the density meter 54, although the scope of the invention is not intended to be limited to any particular arrangement of the meters.

The functionality of the processor module 58 may be implemented using hardware, software, firmware, or a combination thereof. In a typical software implementation, the processor modules would include one or more microprocessor-based architectures having a microprocessor, a random access memory (RAM), a read only memory (ROM), input/output devices and control, data and address buses connecting the same. A person skilled in the art would be able to program such a microprocessor-based implementation to perform the functionality described herein without undue experimentation. The scope of the

invention is not intended to be limited to any particular implementation using technology either now known or later developed in the future.

By way of example, the flotation system 56 is shown in Figure 3b as having a flotation device 62 and a reagent dosing module 64 for providing the reagent dosing along line 64a in response to the signal along line 58a (see Figure 3a) from the processor module 58. The flotation device 62 receives the flotation feed along the input line 60 and the reagent dosing along line 64a, and provides a flotation output slurry based on the same. Such a flotation system like element 56, including such a flotation device 62 and such a reagent dosing module 64, is known in the art, and the scope of the invention is not intended to be limited to any particular type or kind thereof either now known or later developed in the future.

The flotation stage 50 and flotation system 56 may also include one or more elements, devices, apparatus or equipment that are known in the art, do not form part of the underlying invention, and are not disclosed herein or described in detail for that reason.

Figure 3c shows an alternative embodiment of a flotation stage that forms part of a mineral extraction processing system for extracting minerals from ore, where the density meter takes the form of a nuclear density gauge that measure the nuclear density and provides a signal containing information about a nuclear density measurement. Nuclear density gauges are known in the art and the scope of the invention is not intended to be limited to any particular type or kind thereof.

The scope of the invention re flotation stage applications is not intended to be limited to the type or kind of mineral being processed, or the type of mineral process, either now known or later developed in the future. By way of example, the scope of the invention is intended to include flotation stage applications including (but not limited to): Molybdenum, Lead, Zinc, Iron, Gold, Silver, Nickel, Fluorite, Tantalum, Tungsten, Tin, Lithium, Coal.

Figures 4 and 4a: Post-Flotation Stage 100

Figure 4 shows a post-flotation stage generally indicated as 100 that forms part of a mineral extraction processing system for extracting minerals from ore. The present invention as it relates to the post-flotation stage 100 is described in relation to the mineral extraction processing system taking the form of a copper concentrator, although the scope of the invention is not intended to be limited to any particular type or kind of mineral extraction processing system either now known or later developed in the future. The post-flotation stage 100 is described in relation to the flotation stage 50 (Figure 3) that provides the flotation output slurry in the form of a final product along line 50a, although the scope of the invention is intended to include the post-flotation stage 100 being post some other stage in the mineral extraction processing system either now known or later developed in the future.

The post-flotation stage 100 includes a SONAR-based volumetric flow/gas volume fraction (VF/GVF) meter 102, a density meter 104 and a processor module 106.

The SONAR-based VF/GVF meter 102 is placed on the line pipe 50a at the end of the mineral extraction processing system in relation to the flotation stage 50. The line pipe 50a provides a slurry having minerals and varying amounts of entrained air from the flotation stage 50. The SONAR-based

5 VF/GVF meter 102 is configured to sense the volumetric flow of the slurry and provide a signal along line 102a containing information about the volumetric flow that is not substantially affected by the varying amounts of entrained air in the slurry. The SONAR-based VF/GVF meter 102 is known in the art, and disclosed by way of example in whole or in part in the aforementioned United States Patent

10 Nos. 7,165,464; 7,134,320; 7,363,800; 7,367,240; and 7,343,820. Consistent with that described above, the scope of the invention is also intended to include other types or kinds of SONAR-based VF/GVF meters either now known or later developed in the future that perform the same basic functionality of the SONAR-based VF/GVF meter 102 as such functionality relates to implementing the

15 present invention.

The processor module 106 is configured to respond to the signal along line 102a from the SONAR-based VF/GVF meter 102, and also configured to provide an output signal along line 106a containing information about a final product accounting of the slurry in the post-flotation stage 100.

20 The density meter 104 is placed on the feed line pipe in relation to the SONAR-based VF/GVF meter 102 and is configured to provide a signal along line 104a containing information about a density measurement of the slurry to the processor module 106. Consistent with that described above, the density meter

104 is known in the art, and disclosed by way of example in whole or in part in United States Patent Nos. 7,165,464; 7,134,320; 7,363,800; 7,367,240; and 7,343,820. The scope of the invention is also intended to include other types or kinds of meters like meter 104 either now known or later developed in the future
5 that perform the same basic functionality of the meter 104 as such functionality relates to implementing the present invention. In operation, the SONAR-based VF/GVF meter 102 is configured to measure the amount of entrained air which may be used by the processor module 106 to correct errors in the density measurement of the fluid, according to some embodiments of the present
10 invention. For example, the processor module 106 may use the errors in the density measurement of the fluid to determine and provide the output signal along line 106a containing information about a final product accounting of the slurry in the stage, according to the present invention. By way of example, and consistent with that discuss above, the technique for making this measurement and correction is disclosed in whole or in part in United States Patent Nos.
15 7,165,464; 7,134,320; 7,363,800; 7,367,240; and 7,343,820. Moreover, by way of example, the present invention is disclosed with the meter 102 being arranged in front of the density meter 104, although the scope of the invention is not intended to be limited to any particular arrangement of the meters.

20 The functionality of the processor module 106 may be implemented using hardware, software, firmware, or a combination thereof. In a typical software implementation, the processor modules would include one or more microprocessor-based architectures having a microprocessor, a random access

memory (RAM), a read only memory (ROM), input/output devices and control, data and address buses connecting the same. A person skilled in the art would be able to program such a microprocessor-based implementation to perform the functionality described herein without undue experimentation. The scope of the invention is not intended to be limited to any particular implementation using technology either now known or later developed in the future.

The post-flotation stage 100 may also include one or more elements, devices, apparatus or equipment that are known in the art, do not form part of the underlying invention, and are not disclosed herein or described in detail for that reason.

Figure 4a shows a generalized diagram of the application of SONAR to an industrial process to improve final product accounting, including a sonar meter and a density meter that provide signalling containing information about density, gas void fraction and volumetric flow and an algorithm that forms part of a processing module that receives the signalling and provides corresponding signalling containing information about density and mass flow corrected gas. The industrial process may include those either now known or later developed in the future, including any mineral process, as well as mineral extraction processing systems,

The scope of the invention re post-stage applications is not intended to be limited to the type or kind of mineral being processed, or the type of mineral process, either now known or later developed in the future. By way of example, the scope of the invention is intended to include final accounting applications for

The Scope of the Invention

While the invention has been described with reference to an exemplary embodiment, it will be understood by those skilled in the art that various changes may be made and equivalents may be substituted for elements thereof without departing from the scope of the invention. In addition, may modifications may be made to adapt a particular situation or material to the teachings of the invention without departing from the essential scope thereof. Therefore, it is intended that the invention not be limited to the particular embodiment(s) disclosed herein as the best mode contemplated for carrying out this invention.

10

WHAT IS CLAIMED IS:

1. A processor module comprising:

one or more modules configured to respond to one or more input signals containing information about a volumetric flow of a fluid having minerals and varying amounts of entrained gas flowing in a pipe and being processed in a processing stage of a mineral extraction processing system for extracting a mineral from ore, and also configured to provide one or more output signals containing information about operations of the processing stage of the mineral extraction processing system that is not substantially affected by the varying amounts of entrained gas in the fluid flowing in the pipe.

2. A processor module according to claim 1, wherein the one or more output signals controls the operations of the processing stage.

3. A processor module according to claim 1, wherein the one or more input signals is based at least partly on a speed of sound measurement, including a SONAR-based entrained gas measurement to determine the amount of entrained air in conjunction with a density measurement of the fluid flowing in the pipe.

20

4. A processor module according to claim 1, wherein the one or more input signals is received from a SONAR-based volumetric flow/gas volume fraction meter placed on a feed line pipe providing the fluid to the processing stage.

5

5. A processor module according to claim 1, wherein the one or more input signals is received from a SONAR-based volumetric flow/gas volume fraction meter placed on an output line pipe receiving the fluid from the processing stage.

10

6. A processor module according to claim 4, wherein the one or more input signals is also based at least partly on a gas volume measurement that depends on acoustic pressures sensed in the fluid flowing in the pipe.

15

7. A processor module according to claim 1, wherein the one or more output signals depends on an error correction based at least partly on the amount of entrained air in the fluid.

20

8. A processor module according to claim 7, wherein the error correction corrects errors in a density measurement of the fluid, including a nuclear density measurement.

9. A processor module according to claim 1, wherein the fluid is a slurry made up of high solids which contain varying amounts of entrained air.

10. A processor module according to claim 1, wherein the processing
5 stage forms part of copper concentrator.

11. A processor module according to claim 4, wherein the SONAR-based volumetric flow/gas volume fraction meter is placed on the feed line pipe providing the fluid to a hydrocyclone in a grinding stage.

10

12. A processor module according to claim 11, wherein a density meter is also placed on the feed line pipe and provides a density measurement of the fluid.

15

13. A processor module according to claim 12, wherein the SONAR-based volumetric flow/gas volume fraction meter measures the amount of entrained air which is used to correct errors in the density measurement of the fluid.

20

14. A processor module according to claim 13, wherein the one or more output signals controls a hydrocyclone split that provides a flotation feed from the hydrocyclone.

15. A processor module according to claim 14, wherein the hydrocyclone forms part of a hydrocyclone battery.

16. A processor module according to claim 4, wherein the SONAR-based
5 volumetric flow/gas volume fraction meter is placed on the feed line pipe providing the fluid to a flotation stage.

17. A processor module according to claim 16, wherein a density meter is also placed on the feed line pipe providing the fluid to the flotation stage.
10

18. A processor module according to claim 16, wherein the one or more output signals controls the operations of a dosing of a reagent in the flotation stage based on a substantially exact measured mass flow rate of the ore.

19. A processor module according to claim 16, wherein the SONAR-based
15 volumetric flow/gas volume fraction meter makes a direct measurement of a mass flow of ore entering the flotation stage.

20. A processor module according to claim 5, wherein the SONAR-based
20 volumetric flow/gas volume fraction meter is placed on an output line pipe receiving the fluid at the end of the mineral extraction processing system.

21. A processor module according to claim 20, wherein a density meter is also placed on the output line pipe providing a density measurement of the fluid.

22. A processor module according to claim 21, wherein the SONAR-based volumetric flow/gas volume fraction meter measures the amount of entrained air which is used to correct errors in the density measurement of the fluid.

23. A processor module according to claim 22, wherein the one or more output signals provides information about a final product accounting.

10

24. A grinding stage in a mineral extraction processing system for extracting minerals from ore comprising:

a SONAR-based volumetric flow/gas volume fraction meter that is placed on a feed line pipe in relation to a hydrocyclone battery, and configured to provide a signal containing information about a volumetric flow of a slurry having minerals and varying amounts of entrained air that is not substantially affected by the varying amounts of entrained air in the slurry; and

a processor module configured to respond to the signal, and also configured to provide an output signal containing information to control a hydrocyclone split that provides a flotation feed from the hydrocyclone battery.

20

25. A grinding stage according to claim 24, wherein the grinding stage comprises a density meter that is placed on the feed line pipe in relation to the SONAR-based volumetric flow/gas volume fraction meter and that is configured to provide a density measurement of the slurry.

5

26. A grinding stage according to claim 25, wherein the SONAR-based volumetric flow/gas volume fraction meter is configured to measure the amount of entrained air which is used by the processor module to correct errors in the density measurement of the fluid.

10

27. A grinding stage according to claim 26, wherein the grinding stage forms part of a copper concentrator.

28. A flotation stage in a mineral extraction processing system for
15 extracting minerals from ore comprising:

a SONAR-based volumetric flow/gas volume fraction meter that is placed on a feed line pipe, and configured to provide a signal containing information about a volumetric flow of a slurry having minerals and varying amounts of entrained air that is not substantially affected by the varying amounts of entrained
20 air in the slurry; and

a processor module configured to respond to the signal, and also configured to provide an output signal containing information to control a dosing of a reagent that is provided to the slurry in the flotation stage.

29. A flotation stage according to claim 28, wherein the SONAR-based volumetric flow/gas volume fraction meter makes a direct measurement of a mass flow of ore entering the flotation stage.

5

30. A flotation stage according to claim 28, wherein the flotation stage comprises a density meter, including a nuclear density gauge, that is placed on the feed line pipe in relation to the SONAR-based volumetric flow/gas volume fraction meter and that is configured to provide a density measurement, including
10 a nuclear density measurement, of the slurry.

31. A flotation stage according to claim 30, wherein the SONAR-based volumetric flow/gas volume fraction meter is configured to measure the amount of entrained air which is used by the processor module to correct errors in the
15 density measurement of the fluid.

32. A flotation stage according to claim 28, wherein the reagent is dosed based on a measured mass flow rate.

20 33. A flotation stage according to claim 28, wherein the flotation stage forms part of a copper concentrator.

34. A stage in a mineral extraction processing system for extracting minerals from ore comprising:

a SONAR-based volumetric flow/gas volume fraction meter that is placed on an output line pipe at the end of the mineral extraction processing system,
5 and configured to provide a signal containing information about a volumetric flow of a slurry having minerals and varying amounts of entrained air that is not substantially affected by the varying amounts of entrained air in the slurry; and

a processor module configured to respond to the signal, and also configured to provide an output signal containing information about a final
10 product accounting of the slurry in the stage.

35. A stage according to claim 34, wherein a density meter is also placed on the output line pipe providing a density measurement of the slurry.

15 36. A stage according to claim 35, wherein the SONAR-based volumetric flow/gas volume fraction meter measures the amount of entrained air which is used to correct errors in the density measurement of the fluid.

20 37. A stage according to claim 36, wherein the stage forms part of a copper concentrator.

38. A method comprising:

responding with one or more modules to one or more input signals containing information about a volumetric flow of a fluid having minerals and varying amounts of entrained gas flowing in a pipe and being processed in a processing stage of a mineral extraction processing system for extracting a mineral from ore; and

providing with one or more modules one or more output signals containing information about operations of the processing stage of the mineral extraction processing system that is not substantially affected by the varying amounts of entrained gas in the fluid flowing in the pipe.

39. A method according to claim 38, wherein the method comprises controlling with the one or more output signals the operations of the processing stage.

40. A method according to claim 38, wherein the one or more input signals is based at least partly on a speed of sound measurement, including a SONAR-based entrained gas measurement to determine the amount of entrained air in conjunction with a density measurement of the fluid flowing in the pipe.

41. A method according to claim 38, wherein the method comprises placing a SONAR-based volumetric flow/gas volume fraction meter on a feed line pipe providing the fluid to the processing stage that is configured to provide one or more input signals.

5

42. A method according to claim 38, wherein the method comprises placing a SONAR-based volumetric flow/gas volume fraction meter on an output line pipe receiving the fluid from the processing stage that is configured to provide the one or more input signals.

10

43. A method according to claim 42, wherein the one or more input signals is also based at least partly on a gas volume measurement that depends on acoustic pressures sensed in the fluid flowing in the pipe.

15

44. A method according to claim 38, wherein the one or more output signals depends on an error correction based at least partly on the amount of entrained air in the fluid.

20

45. A method according to claim 44, wherein the error correction corrects errors in a density measurement of the fluid.

46. A method according to claim 38, wherein the fluid is a slurry made up of high solids which contain varying amounts of entrained air.

47. A processor module comprising:

one or more modules configured to respond to one or more input signals containing information about a volumetric flow of a fluid having minerals and
5 varying amounts of entrained gas flowing in a pipe and being processed in a stage of any mineral process, and also configured to provide one or more output signals containing information about operations of the stage of the mineral process that is not substantially affected by the varying amounts of entrained gas in the fluid flowing in the pipe.

10

FIGURE 1a: Mineral Extraction Processing System – Prior Art

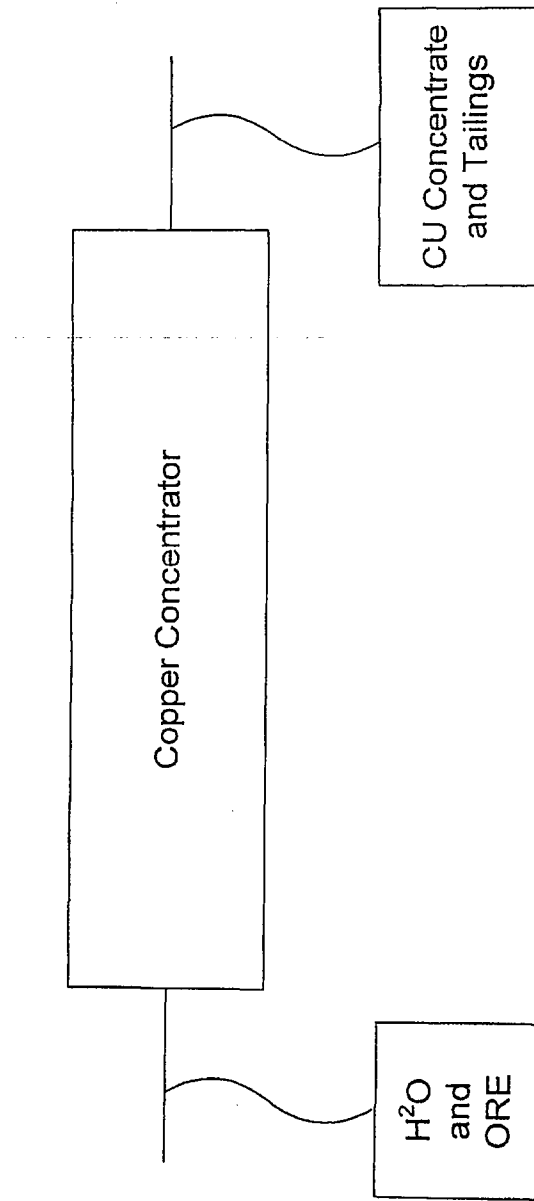
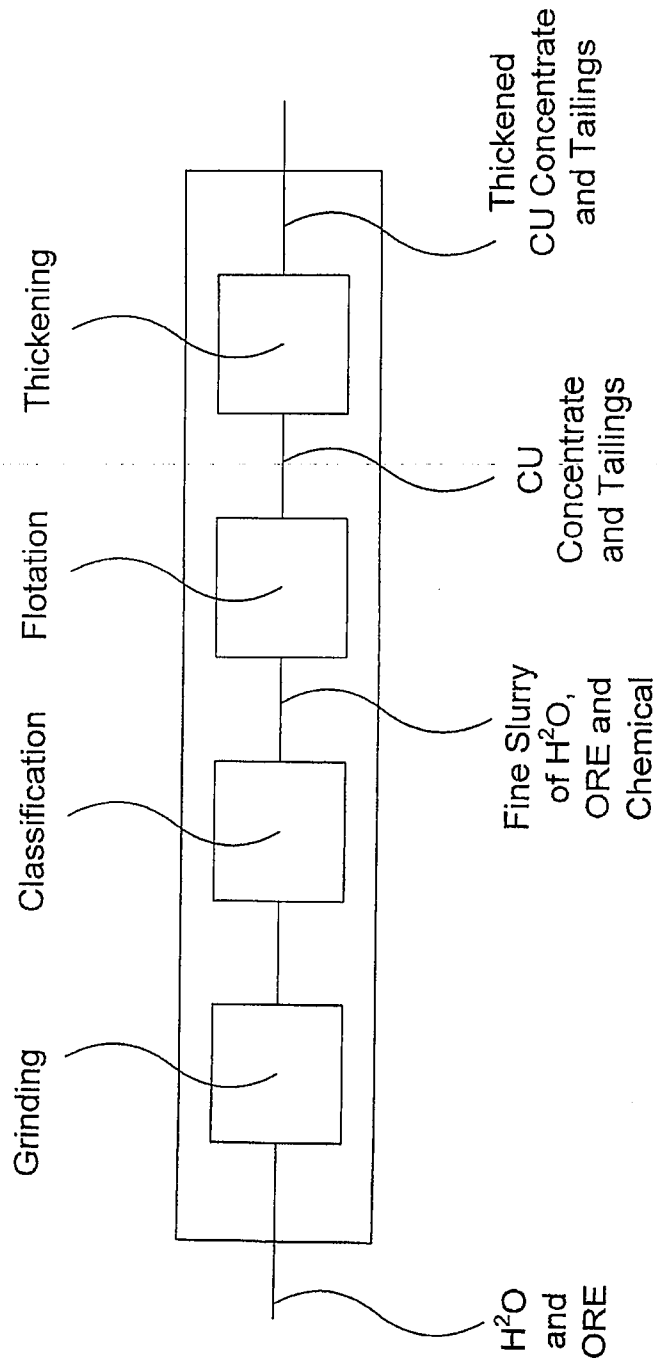

FIGURE 1b – Prior Art



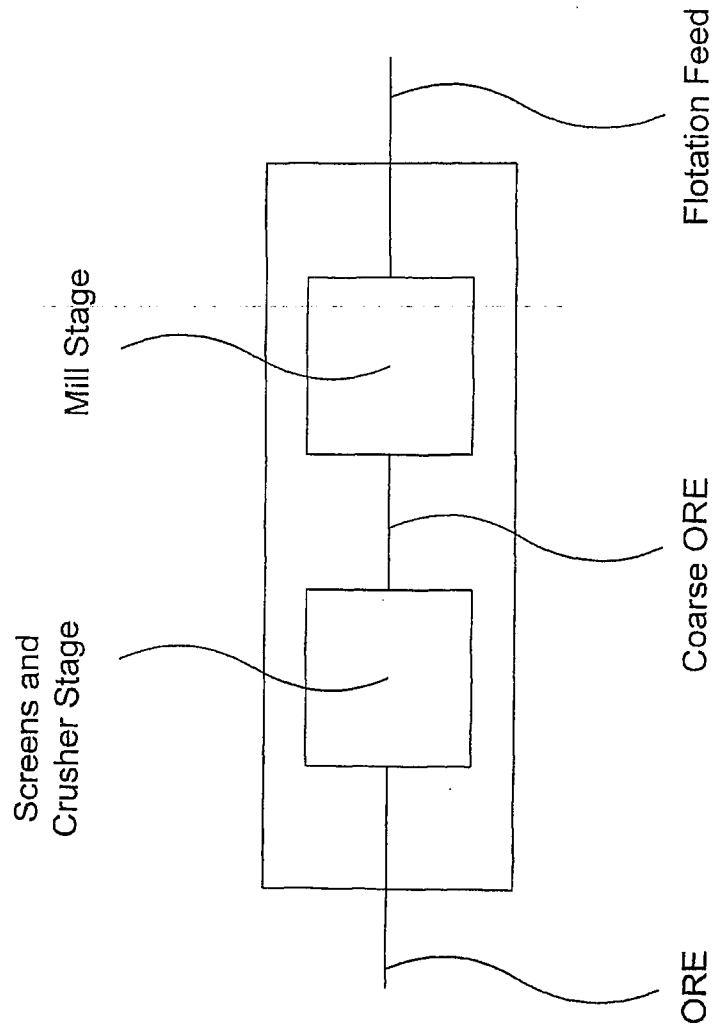

FIGURE 1c: Grinding – Prior Art

FIGURE 2: Grinding Stage

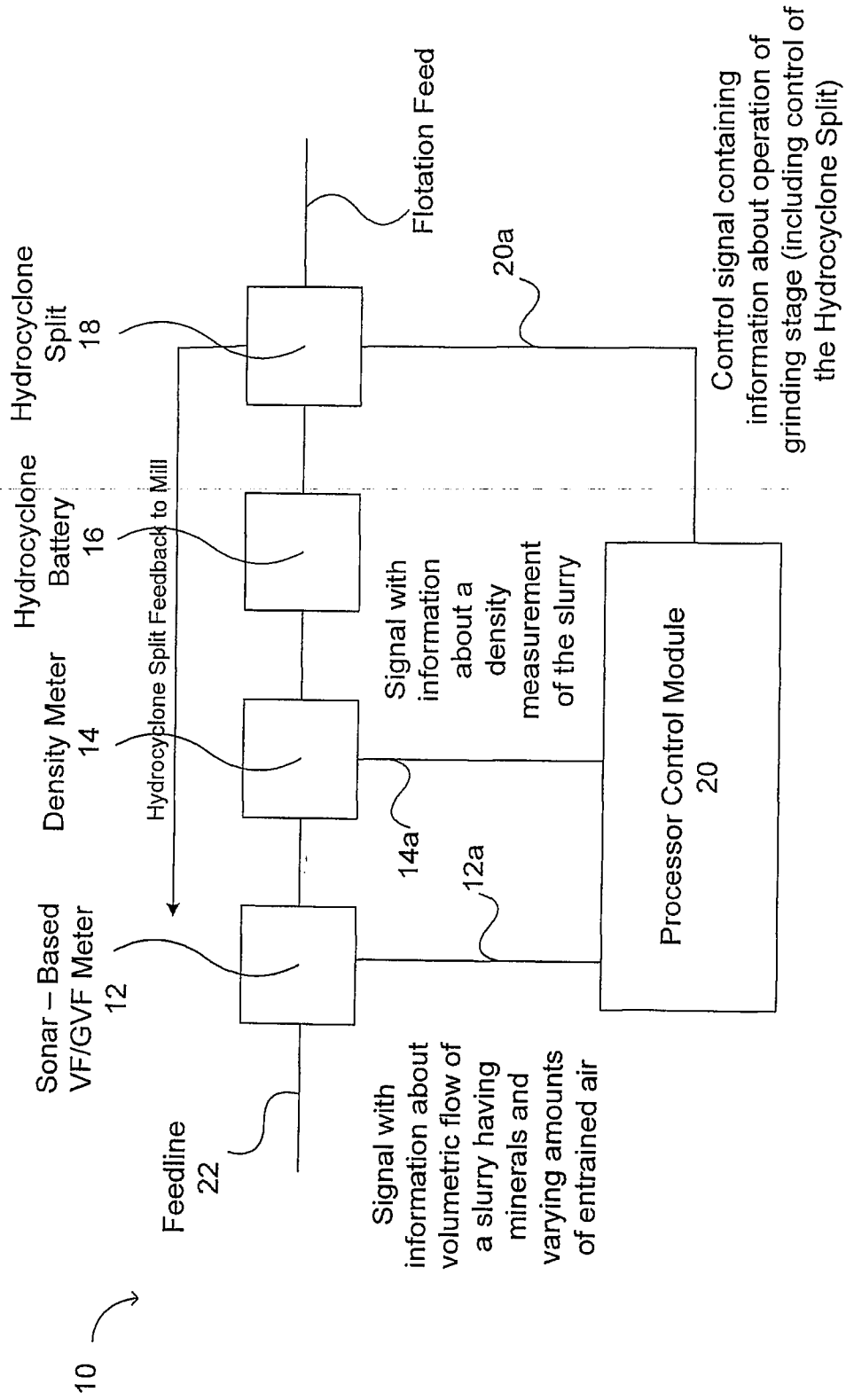

FIGURE 3a: Flotation Stage

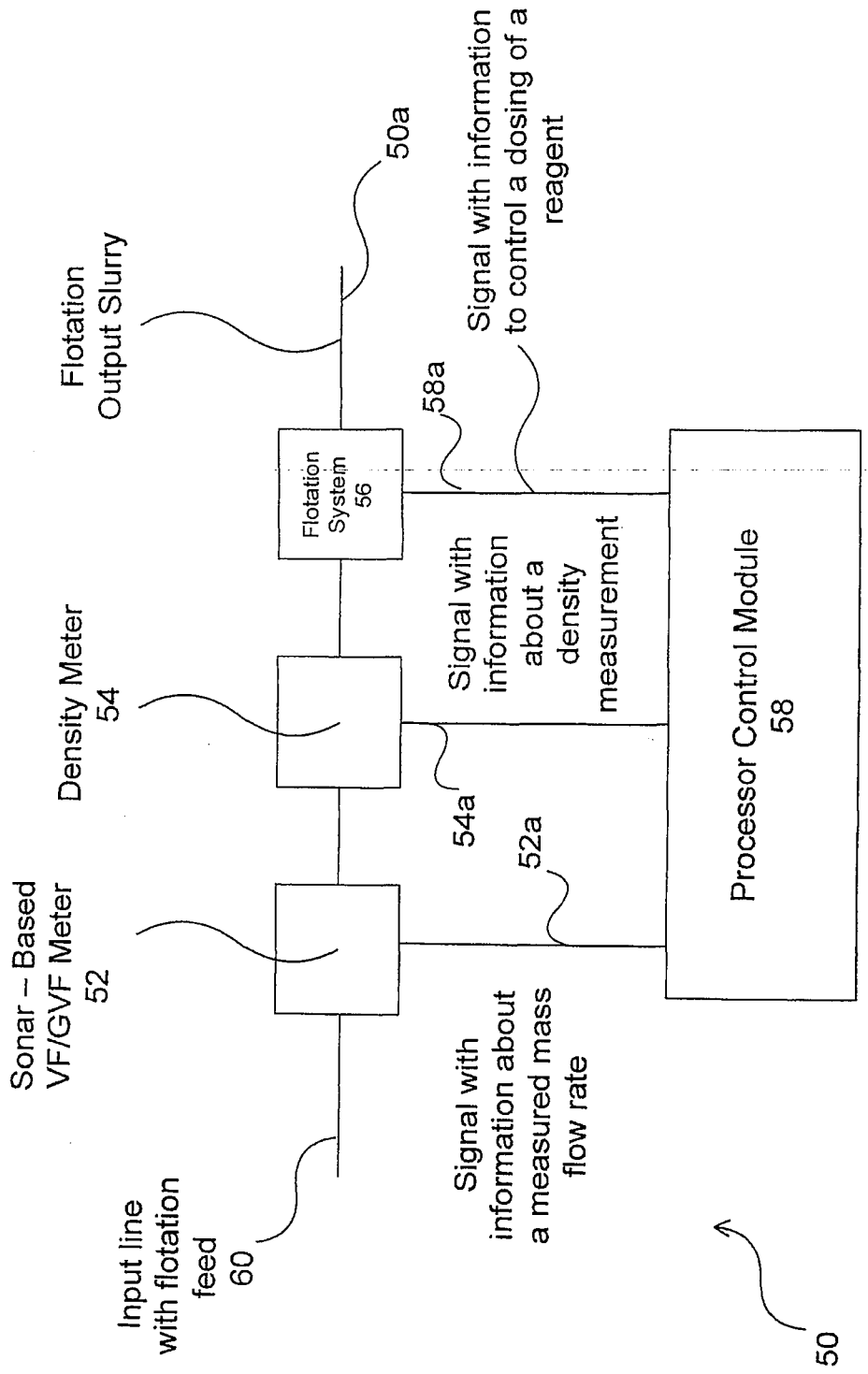
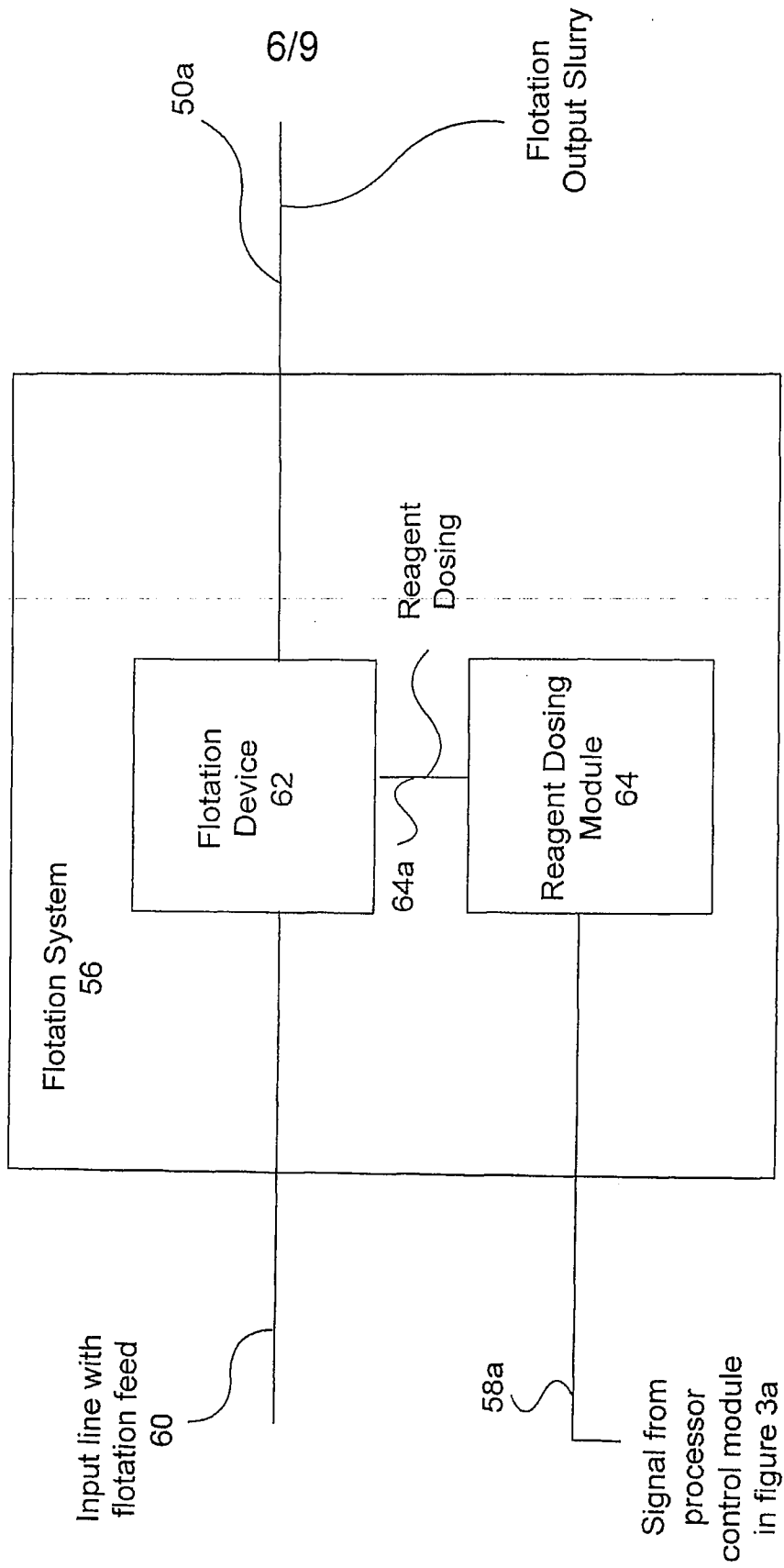

FIGURE 3b:



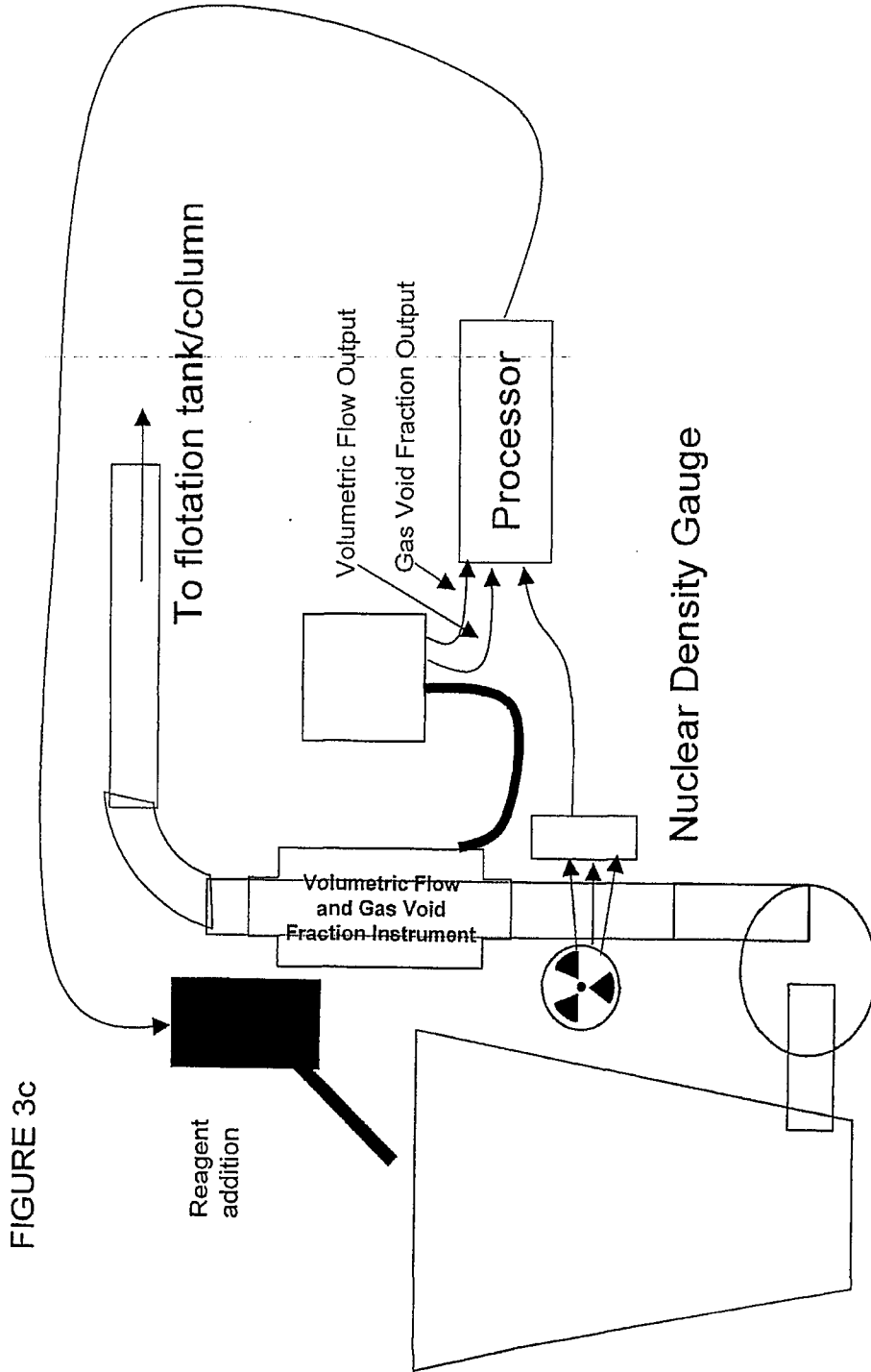

FIGURE 3c

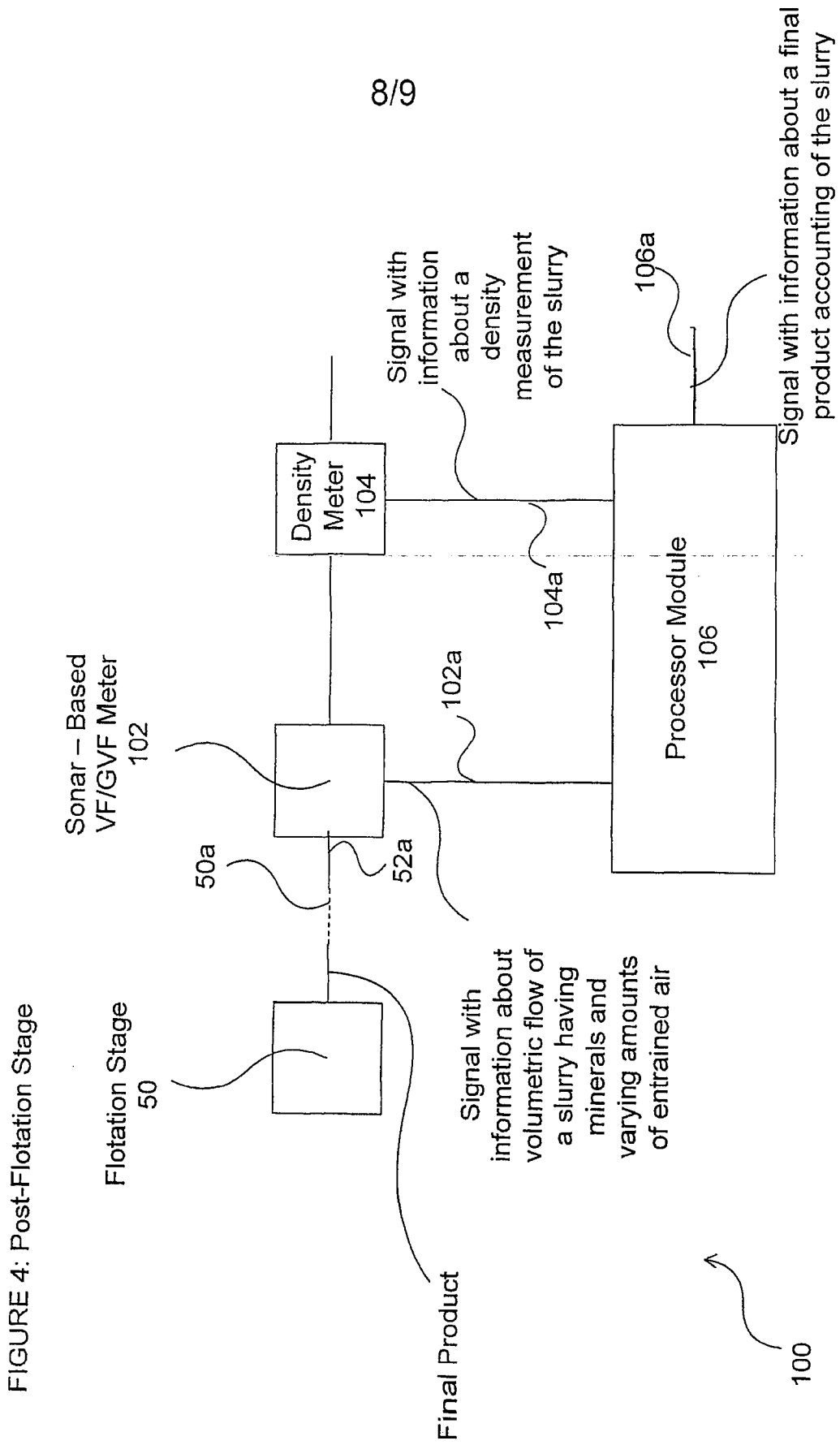
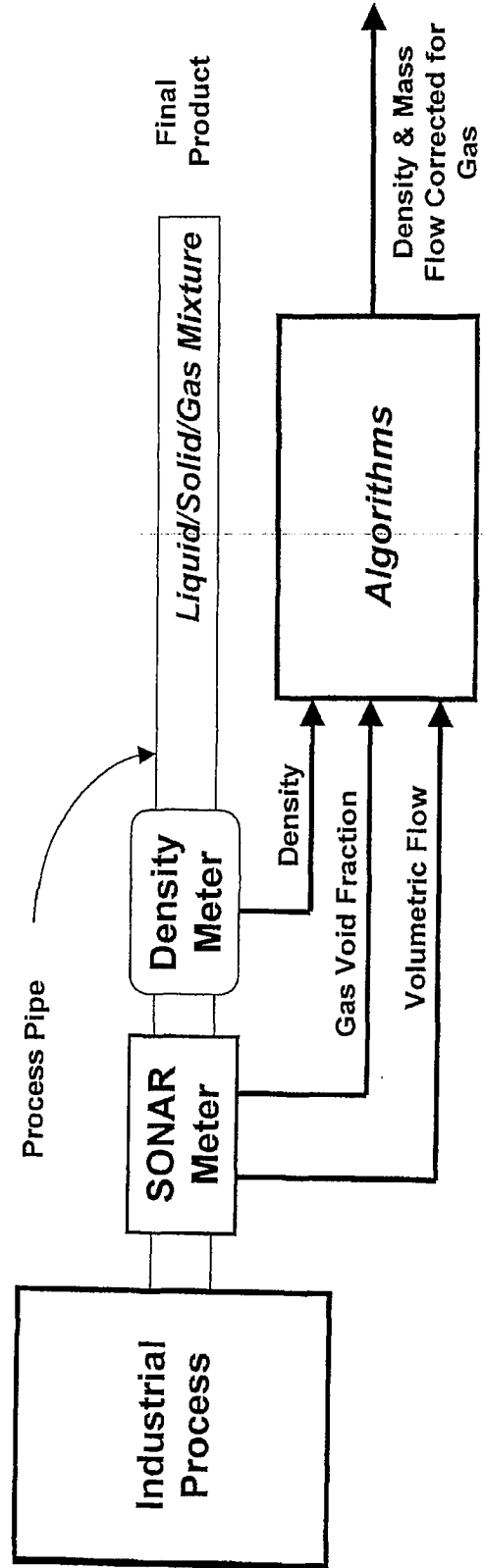

FIGURE 4a



INTERNATIONAL SEARCH REPORT

International application No.

PCT/US 09/43438

A. CLASSIFICATION OF SUBJECT MATTER IPC(8) - G01S 15/00, G01F 1/00 (2009.01) USPC - 181/123; 702/100 According to International Patent Classification (IPC) or to both national classification and IPC		
B. FIELDS SEARCHED Minimum documentation searched (classification system followed by classification symbols) USPC - 181/123; 702/100 Documentation searched other than minimum documentation to the extent that such documents are included in the fields searched USPC- 181/101, 102, 105, 110, 123; 702/1, 6, 12, 45, 50, 100, 127, 143; 116/112; 73/37 (keyword limited, see terms below)		
Electronic data base consulted during the international search (name of data base and, where practicable, search terms used) PubWEST(PGPB,USPT,EPAB,JPAB); Google. Search Terms Used: SONAR, volume, flow, meter, density, slurry, gas, fraction, hydrocyclone, hydroclone, cyclone separator, flow rate, mineral, ore, pipe, tube, conduit, speed, volume, reagent, doping, dosing, extract, float, grind		
C. DOCUMENTS CONSIDERED TO BE RELEVANT		
Category*	Citation of document, with indication, where appropriate, of the relevant passages	Relevant to claim No.
Y	US 2005/0061060 A1 (Gysling et al.) 24 March 2005 (24.03.2005) entire document, especially: Fig. 1, 6, 9, para. [0015], [0016], [0039]-[0042], [0058]-[0064], [0069], [0073], [0117]-[0124]	1-47
Y	US 2006/0219603 A1 (Bourke) 05 October 2006 (05.10.2006) para. [0003], [0023], [0024], [0042]	1-47
Y	US 2005/0150330 A1 (Rajic et al.) 14 July 2005 (14.07.2005) para. [0061]	10, 27, 33, 37
A	US 2004/0255695 A1 (Gysling et al.) 23 December 2004 (23.12.2004) entire document	1-47
<input type="checkbox"/> Further documents are listed in the continuation of Box C. <input type="checkbox"/>		
* Special categories of cited documents: "A" document defining the general state of the art which is not considered to be of particular relevance "E" earlier application or patent but published on or after the international filing date "L" document which may throw doubts on priority claim(s) or which is cited to establish the publication date of another citation or other special reason (as specified) "O" document referring to an oral disclosure, use, exhibition or other means "P" document published prior to the international filing date but later than the priority date claimed "T" later document published after the international filing date or priority date and not in conflict with the application but cited to understand the principle or theory underlying the invention "X" document of particular relevance; the claimed invention cannot be considered novel or cannot be considered to involve an inventive step when the document is taken alone "Y" document of particular relevance; the claimed invention cannot be considered to involve an inventive step when the document is combined with one or more other such documents, such combination being obvious to a person skilled in the art "&" document member of the same patent family		
Date of the actual completion of the international search 24 June 2009 (24.06.2009)		Date of mailing of the international search report 02 JUL 2009
Name and mailing address of the ISA/US Mail Stop PCT, Attn: ISA/US, Commissioner for Patents P.O. Box 1450, Alexandria, Virginia 22313-1450 Facsimile No. 571-273-3201		Authorized officer: Lee W. Young PCT Helpdesk: 571-272-4300 PCT OSP: 571-272-7774