

(19)  
(12)

(KR)  
(A)

(51) 。 Int. Cl. 7  
H01L 21/027

(11)  
(43)

2002 - 0036739  
2002 05 16

(21) 10 - 2001 - 0069647  
(22) 2001 11 09

(30) JP - P - 2000 - 0034 2000 11 10 (JP)  
3985

(71) 가 가  
가  
5 7 1

(72) 5 7 1 가 가

(74)  
:

(54)

2 , 가 가 ,

1

, , ,

1

가 .

2a 2b  
) .

(A - A'

3

4a 4b

5 가

6a 6b , (B - B' )

7

가

(stepper)

, CCD

가

5

가

(B - B' )

6  
7

(contact step)

5

(110)

(120)

(120)

(121)

2

가

(123)

(123)

7

가

가

2

가

가

가

1

2

(A - A' )

1 , (10) (11) 가 , (11)  
(13) (12) 가 가 ,

, 1 (10) , 2 ,  
, (12) (23) . ,

3

CCD

가

( 6 ) 가 , 가 ( 7 ) .

가

% 가 25 % , 가 가 25  
30 % 40 % 가 가  
가 가

가 4a 4b  
4a 가

4a 4b

가 가 가/ , 4b  
가 25 % .

가 가 , 2 .

가

가

(57)

1.

가 ;

2

가

2.

1 ,

3.

1 ,

25 %

4.

1 ,

30 %

5.

1 ,

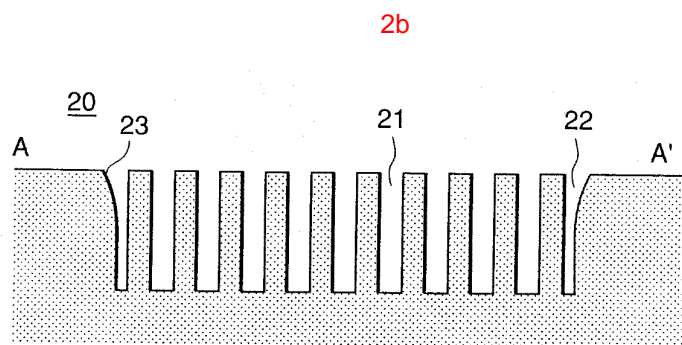
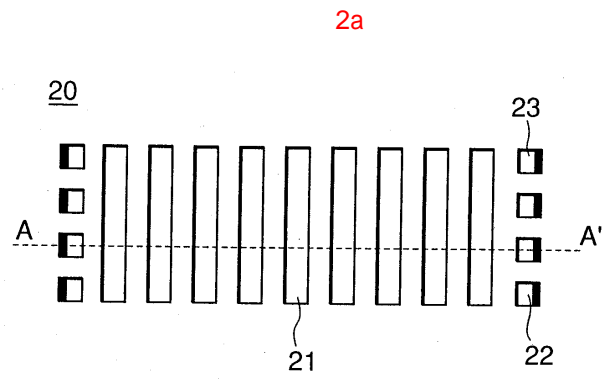
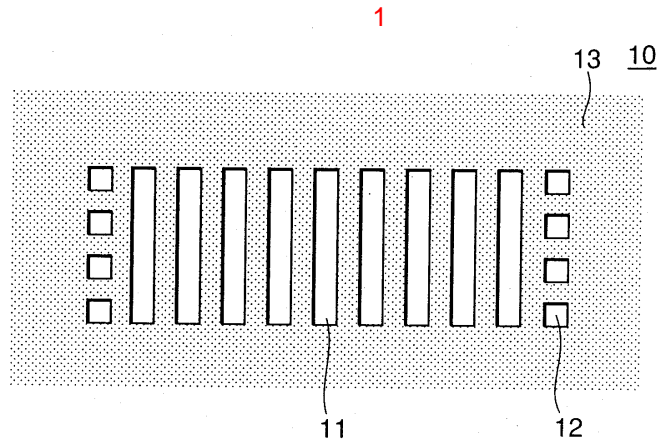

3

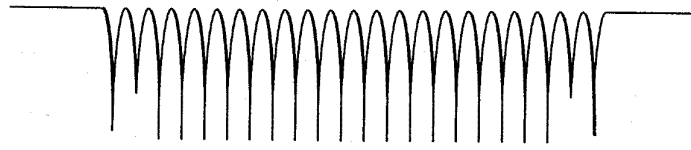

4a

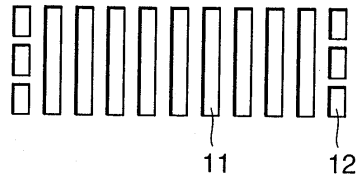

4b

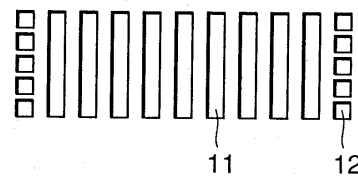

5

### 종래 기술

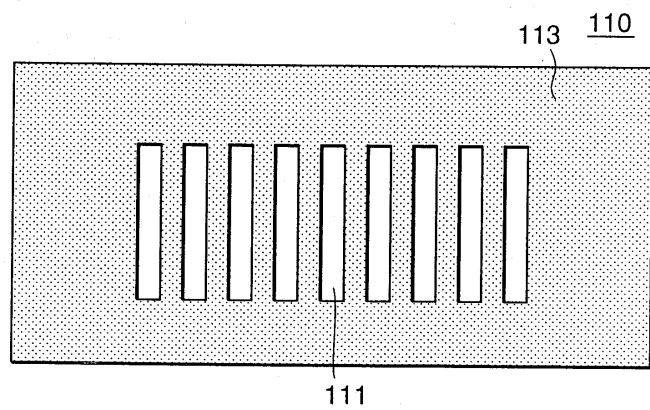

6a

종래 기술

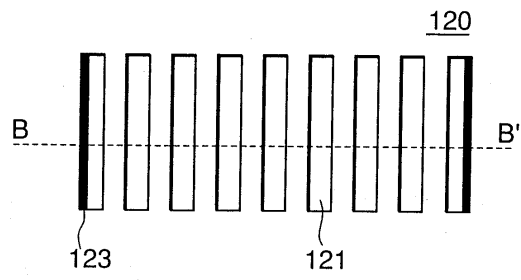

6b

종래 기술

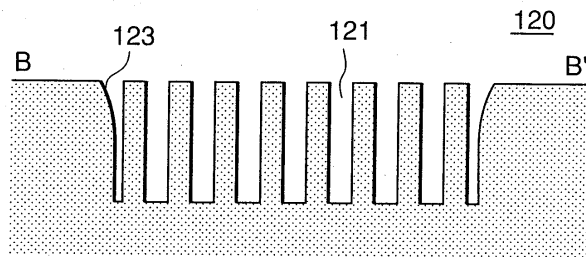

7

종래 기술

