

(19) World Intellectual Property Organization
International Bureau



(43) International Publication Date
11 October 2001 (11.10.2001)

PCT

(10) International Publication Number
WO 01/75433 A2

- (51) International Patent Classification⁷: **G01N 33/00**
- (21) International Application Number: PCT/US01/09237
- (22) International Filing Date: 22 March 2001 (22.03.2001)
- (25) Filing Language: English
- (26) Publication Language: English
- (30) Priority Data:
09/541,376 31 March 2000 (31.03.2000) US
- (71) Applicant: **LIFESCAN, INC.** [US/US]; 1000 Gibraltar Drive, Milpitas, CA 95035 (US).
- (72) Inventor: **SHARTLE, Robert, Justice**; 1264 Geneve Court, Livermore, CA 94550 (US).
- (74) Agents: **JOHNSON, Philip, S.** et al.; Johnson & Johnson, One Johnson & Johnson Plaza, New Brunswick, NJ 08933 (US).
- (81) Designated States (*national*): AE, AG, AL, AM, AT, AU, AZ, BA, BB, BG, BR, BY, BZ, CA, CH, CN, CR, CU, CZ, DE, DK, DM, DZ, EE, ES, FI, GB, GD, GE, GH, GM, HR, HU, ID, IL, IN, IS, JP, KE, KG, KP, KR, KZ, LC, LK, LR, LS, LT, LU, LV, MA, MD, MG, MK, MN, MW, MX, MZ, NO, NZ, PL, PT, RO, RU, SD, SE, SG, SI, SK, SL, TJ, TM, TR, TT, TZ, UA, UG, UZ, VN, YU, ZA, ZW.
- (84) Designated States (*regional*): ARIPO patent (GH, GM, KE, LS, MW, MZ, SD, SL, SZ, TZ, UG, ZW), Eurasian patent (AM, AZ, BY, KG, KZ, MD, RU, TJ, TM), European patent (AT, BE, CH, CY, DE, DK, ES, FI, FR, GB, GR, IE, IT, LU, MC, NL, PT, SE, TR), OAPI patent (BF, BJ, CF, CG, CI, CM, GA, GN, GW, ML, MR, NE, SN, TD, TG).
- Published:**
— without international search report and to be republished upon receipt of that report
- For two-letter codes and other abbreviations, refer to the "Guidance Notes on Codes and Abbreviations" appearing at the beginning of each regular issue of the PCT Gazette.*

(54) Title: CAPILLARY FLOW CONTROL IN A FLUIDIC DIAGNOSTIC DEVICE

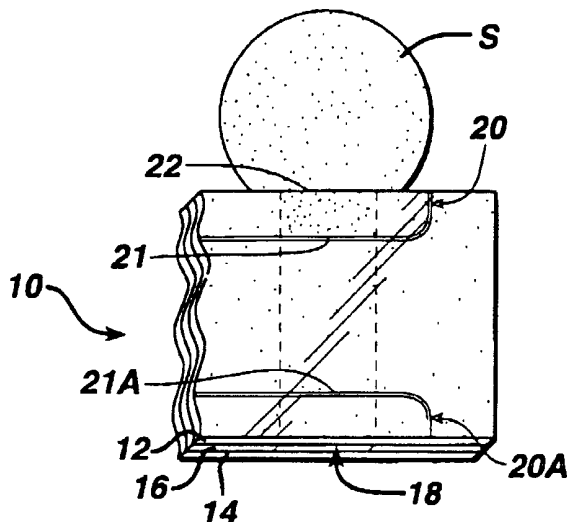

(57) Abstract: A medical diagnostic device for measuring an analyte concentration or property of a biological fluid includes capillary flow channels to convey a sample of the fluid from an inlet to a branching point, and then to a measurement area and, alternatively, through a bypass channel to an overflow region. A first stop junction stops fluid flow after it enters the measurement area. The bypass channel has a capillary dimension in at least one direction. A second stop junction, in the bypass channel, has a boundary region that has a dimension that is greater in that direction and forms an angle that points toward the branching point. With this construction, the second stop junction initially prevents flow to the overflow region, but permits the flow after the measurement area is filled. The device is particularly suited for measuring coagulation time of blood.



WO 01/75433 A2

CAPILLARY FLOW CONTROL IN A FLUIDIC DIAGNOSTIC DEVICE

Cross-reference to Prior Application

- 5 This application relates to pending U.S. Applications 09/333,765, filed June 15, 1999; and 09/354,995, filed July 16, 1999.

BACKGROUND OF THE INVENTION

10 1. Field of the Invention

 This invention relates to a medical diagnostic device that includes an element for controlling fluid flow through the device; more particularly, to a device that facilitates fluid flow through a stop junction.

15 2. Description of the Related Art

 A variety of medical diagnostic procedures involve tests on biological fluids, such as blood, urine, or 20 saliva, to determine an analyte concentration in the fluid. The procedures measure a variety of physical parameters - mechanical, optical, electrical, etc., - of the biological fluid.

- 20 Among the analytes of greatest interest is glucose, and dry phase reagent strips incorporating enzyme-based compositions are used extensively in clinical laboratories, physicians' offices, hospitals, and homes to test samples of biological fluids for glucose concentration. In fact, reagent strips have become an everyday necessity for many of the nation's estimated 16 million people with diabetes. Since diabetes can cause
25 dangerous anomalies in blood chemistry, it can contribute to vision loss, kidney failure, and other serious medical consequences. To minimize the risk of these consequences, most people with diabetes must test themselves periodically, then adjust their glucose concentration accordingly, for instance, through diet, exercise, and/or insulin injections. Some patients must test their blood glucose concentration as often as four 10 times
30 or more daily.

- One type of glucose measurement system operates electrochemically, detecting the oxidation of blood glucose on a dry reagent strip. The reagent generally includes an enzyme, such as glucose oxidase or glucose dehydrogenase, and a redox mediator, such as ferrocene or ferricyanide. This type of measurement system is described in U.S.
35 Pat. 4,224,125, issued on September 23, 1980, to Nakamura et al.; and U.S. Pat.

4,545,382, issued on October 8, 1985, to Higgins et al., incorporated herein by reference

Hodges et al., WO 9718464 A1, published on May 22, 1997, discloses an electrochemical device for measuring blood glucose that includes two metallized polyethylene terephthalate (PET) layers sandwiching an adhesive-coated PET intermediate layer. The metallized layers constitute first and second electrodes, and a cutout in the adhesive-coated layer defines an electrochemical cell. The cell contains the reagent that reacts with the glucose in a blood sample. The device is elongated, and the sample is introduced at an inlet on one of the long sides.

The electrochemical devices for measuring blood glucose that are described in the patents cited above, as well as other medical diagnostic devices used for measuring analyte concentrations or characteristics of biological fluids, generally share a need to transport the fluid from a sample inlet to one or more other sections of the device. Typically, a sample flows through capillary channels between two spaced-apart surfaces. A number of patents, discussed below, disclose medical diagnostic devices and include descriptions of various methods to control the flow of the sample.

U.S. Patent 4,254,083, issued on March 3, 1981, to Columbus, discloses a device that includes a sample inlet configured to facilitate movement of a drop of fluid sample into the device, by causing a compound meniscus to form on the drop. (See also U.S. Patent 5,997,817, issued on December 7, 1999 to Crismore et al.)

U.S. Patent 4,426,451, issued on January 17, 1984 to Columbus, discloses a multi-zone fluidic device that has pressure-actuatable means for controlling the flow of fluid between the zones. His device makes use of pressure balances on a liquid meniscus at the interface between a first zone and a second zone that has a different cross section. When both the first and second zones are at atmospheric pressure, surface tension creates a back pressure that stops the liquid meniscus from proceeding from the first zone to the second. The configuration of this interface or "stop junction" is such that the liquid flows into the second zone only upon application of an externally generated pressure to the liquid in the first zone that is sufficient to push the meniscus into the second zone.

U.S. Patent 4,868,129, issued on September 19, 1989 to Gibbons et al., discloses that the back pressure in a stop junction can be overcome by hydrostatic pressure on the liquid in the first zone, for example by having a column of fluid in the first zone.

U.S. Patent 5,230,866, issued on July 27, 1993 to Shartle et al., discloses a fluidic device with multiple stop junctions in which the surface tension-induced back pressure at the stop junction is augmented; for example, by trapping and compressing gas in the second zone. The 15 compressed gas can then be vented before
5 applying additional hydrostatic pressure to the first zone to cause fluid to flow into the second zone. By varying the back pressure of multiple stop junctions in parallel, "rupture junctions" can be formed, having lower maximum 20 back pressure.

U.S. Patent 5,472,603, issued on December 5, 1995 to Schembri (see also U. S. Patent 5,627,041), discloses using centrifugal force to overcome the back pressure in a
10 stop junction. When flow stops, the first zone is at atmospheric pressure plus a centrifugally generated pressure that is less than the pressure required to overcome the back pressure. The second zone is at atmospheric pressure. To resume flow, additional centrifugal pressure is applied to the first zone, overcoming the meniscus back pressure. The second zone remains at atmospheric pressure.

U.S. Patent 6,011,307, issued on December 14, 1999, to Naka et al., published on October 29, 1997, discloses 5 a device and method for analyzing a sample that includes drawing the sample into the device by suction, then reacting the sample with a reagent in an analytical section. Analysis is done by optical or electrochemical means. In alternate embodiments, there are multiple to analytical sections and/or a bypass
20 channel. The flow among these sections is balanced without using stop junctions.

U.S. Patent 5,700,695, issued on December 23, 1997 to Yassinzadeh et al., discloses an apparatus for collecting and manipulating a biological fluid that uses a "thermal pressure chamber" to provide the driving force for moving the sample through the apparatus.

U.S. Patent 5,736,404, issued on April 7, 1998, to Yassinzadeh et al., discloses a
25 method for determining the coagulation time of a blood sample that involves causing an end of the sample to oscillate within a passageway. The oscillating motion is caused by alternately increasing and decreasing the pressure on the sample.

None of the references discussed above suggest a device in which flow channel
30 has a stop junction that is angular in the flow direction.

SUMMARY OF THE INVENTION

This invention provides a medical device for measuring an analyte
concentration or property of a biological fluid. This embodiment of the
35 device comprises

a) a sample inlet for introducing a sample of the biological fluid into the device;

b) a first capillary channel for conveying the sample from the inlet to a branching point;

5 c) a capillary connecting channel for conveying a first part of the sample from the branching point through a measurement area, in which is measured a physical parameter of the sample that is related to the analyte concentration or property of the fluid, and to a first stop junction;

10 d) a capillary bypass channel for conveying a second part of the sample in a first direction from 20 a first region, proximate to the branching point, to an overflow region, distal to the branching point, the first region having a capillary dimension in a second direction substantially perpendicular to the first direction;

15 e) a second stop junction in the bypass channel, comprising a boundary region that

i) separates the first and overflow regions,

ii) has a second predetermined dimension in the second direction that is greater than the capillary dimension, and

20 iii) forms an angle that points toward the 5 first region, whereby any excess sample that enters the sample inlet will pass through the second stop junction into the overflow region.

Devices of the present invention provide, in a capillary flow channel of the device, a stop junction that is angular in the flow direction. Such a stop junction can be
25 designed with readily-controlled breakthrough pressure. Note that in the present specification and the figures, capillaries are shown bounded by parallel plates. In that case, the "second direction", which has the capillary dimension, is uniquely determined. Alternatively, capillaries of the invention could be cylindrical. In that case, the second direction is radial, in a planar circle, or disk, that is perpendicular to the direction of
30 fluid flow.

BRIEF DESCRIPTION OF THE DRAWINGS

Fig. 1 depicts the operation of a stop junction in a medical device.

35 Figs. 2 - 5 depict the flow of a fluid in part of a device of this invention.

Fig. 6 is an exploded perspective view of a device of this invention.

Fig. 7 is a plan view of the device of Fig. 6.

Figs. 7A, 7B, and 7C depict sample filling the device of Fig. 6.

Fig. 8 is a plan view of a preferred embodiment of this invention, which includes three
5 measurement areas.

DETAILED DESCRIPTION OF THE INVENTION

When fluid flows through a channel, a discontinuity in channel cross section can form a "stop junction," which can stop the fluid flow, as described in U.S. Patents
10 4,426,451; 5,230,866; and 5,912,134, incorporated herein by reference. The stop junction results from surface tension that creates a back pressure that stops 15 the fluid meniscus from proceeding through the discontinuity. The stop junction is weakened, and flow thereby enhanced, when the leading edge of the meniscus encounters the vertex of an acute angle and is then stretched along the arms of the
15 angle. This may be 20 described as the angle "pointing" in a direction opposite to the direction of fluid flow.

This invention relates to a medical diagnostic device that has a flow channel with a stop junction. The stop junction is angular in the direction of flow, which 25 permits fluid in the channel to break through. the stop junction when there is a predetermined pressure difference across the stop junction. The advantages of such a controlled break-through stop junction are apparent from the description that follows.
20

Fig. 1 depicts part of a medical diagnostic strip 10 that is a multilayer sandwich. Top layer 12 and bottom layer 14 sandwich intermediate layer 16. A cutout in
25 intermediate layer 16 forms channel 18. Lines 20 and 20A 5 are scored into the bottom surface of layer 12 and form in channel 18 stop junctions 21 and 21A, respectively. Thus, sample S, introduced into channel 18 at sample inlet 22, stops when it reaches stop junction 21.

Figs. 2 and 3 depict the part of a medical to diagnostic strip of Fig. 1 in which
30 stop junctions 21 and 21A have been modified by adding serrations 24 and 24A, respectively. Serration 24 forms an acute angle A that "points" toward sample inlet 22. Figs. 2 and 3 depict sample S just before and just after it breaks through stop junction 21, respectively. Note that the breakthrough occurs first at the vertex that points opposite to the direction of fluid flow. The effectiveness of the serration in enhancing
35 flow through a stop junction in a capillary channel depends on the angle and the length

of the legs that form the angle. The smaller the angle and the longer the legs, the greater the effectiveness of the serration. Thus, if the angle is small and the legs long, only a small hydraulic pressure differential across the scored region will cause the sample to flow through it. Preferably, angle A is less than about 90° and its axis of symmetry is aligned with the direction of flow in the channel.

Stop junction 21A has an angle that points toward end 26 of channel 18 that is opposite inlet 22, and it would have reduced resistance to the flow of sample that entered end 26. Figs. 4 and 5 depict the flow of sample through channel 18 after it has broken through stop junction 21. In Fig. 4, the sample is stopped at stop junction 21A. In Fig. 5, sample has passed through stop junction 21A at its two ends. The breakthroughs occur there, because although the angles at the two ends are greater than 90° , they are smaller than the angle (i.e., the supplement of the angle that points toward 26) at the center of serration 24A. A short time after the sample reaches the position shown in Fig. 5, the sample will pass through stop junction 21A across the entire width of channel 18.

Fig. 6 is an exploded perspective view of an embodiment of the present invention. The diagnostic device 30 has a top layer 32 and bottom layer 34 sandwiching intermediate layer 36. Elements of the device are formed by the layers, together with cutouts in them. Depicted in Fig. 6 are sample inlet 38, formed by coaligned holes in intermediate layer 36 and top layer 32; first capillary channel 40, for conveying sample from sample inlet 38 to branching point 42; and capillary connecting channel 44, for conveying sample through measurement area 46 to a first stop junction 48. Stop junction 48 is formed by the intersection of the 25 capillary neck, at the end of measurement area 46, and the coinciding holes 48A, 48B, and 48C in intermediate layer 36, top layer 32, and bottom layer 34, respectively. Holes 48A, 48B, and 48C are conveniently punched in a single operation when the layers are together. In a less-preferred embodiment, only two holes are needed. Thus 48B or 48C could be omitted. Measurement area 46 preferably contains a reagent 50. Cutout 58 is part of a bladder that includes the 5 adjoining regions of top layer 32 and bottom layer 34. Capillary bypass channel 52 provides an alternate path from branching point 42 to overflow region 54. A stop junction 56 in bypass channel 52 impedes flow into overflow region 54. Stop junction 56 is formed by the intersection of capillary bypass channel 52 and the coinciding holes 56A, 56B, and 56C in intermediate layer 36, top layer 32, and bottom layer 34, respectively. (Either hole 56B or 56C can be omitted). Note that stop junctions 48 and 56 also require seals 48D, 48E, and 56D, 56E, respectively.

Fig. 7 is a top plan view of the device of Fig. 6. The device depicted in Figs. 6 and 7 is particularly well suited for measuring blood-clotting time - "prothrombin time" or "PT time" - and details regarding such a device appear below. The modifications needed to adapt the device for other medical diagnostic applications require no more than routine experimentation. In operation, sample is applied to sample port 38 after bladder 58 has been compressed. Clearly, the region of top layer 32 and/or bottom layer 34 that adjoins the cutout for bladder 58 must be resilient, to permit bladder 58 to be compressed. When the bladder is released, suction draws sample through first capillary channel 40 to branching point 42 and through capillary connecting channel 44 to measurement area 46. In order to ensure that measurement area 46 can be filled with sample, the volume of bladder 58 is preferably at least about equal to the combined volume of first channel 40, connecting channel 44, capillary bypass channel 52, and measurement area 46. If the measurement method is optical, and the measurement area 46 is to be illuminated from below, bottom layer 34 must be transparent where it adjoins measurement area 46. For a PT test, reagent 50 contains thromboplastin that is free of bulking reagents normally found in lyophilized reagents.

As shown in Figs. 6 and 7, sample is drawn into the device by suction, caused by decompression of bladder 58. When the sample reaches stop junction 48, sample flow stops. For PT measurements, it is important to stop the flow of sample as it reaches that point to permit reproducible "rouleaux formation" - the stacking of red blood cells - which is an important step in monitoring blood clotting using the present invention.

The function and operation of the bypass channel can be understood by referring to Figs. 7A, 7B, and 7C which depict a time sequence during which a sample is drawn into device 30 for the measurement.

Fig. 7A depicts the situation after a user has applied a sample to the strip, while bladder 58 is compressed. This can be accomplished by applying one or more drops of blood.

Fig. 7B depicts the situation after the bladder is decompressed. The resulting reduced pressure in the first channel 40 and connecting channel 44 draws the sample initially into the measurement area 46. When the sample reaches stop junction 48, the sample encounters a back pressure that causes it to stop and causes additional sample to be drawn into the bypass channel toward stop junction 56. Note that stop junction 56 is "weaker" than stop junction 48, because it has an angle A that points toward branching

point 42. (See Figs. 1-5). Thus weak stop junction 56 performs two functions. It first impedes the flow of sample into overflow region 54, thus permitting measurement area 46 to fill rapidly. Second, it permits any excess sample to flow through it (after measurement area 46 is full) to relieve any pressure difference remaining on the two sides of stop junction 48. Such a pressure difference could cause sample to "leak" through stop junction 48, causing movement of sample through the measurement area, which is undesirable, for the reason discussed earlier.

Fig. 7C depicts the situation when an equilibrium has been established among the pressures on the sample surfaces - atmospheric pressure on the sample in inlet 38 and the pressure on the free surfaces in overflow region 54 and stop junction 48.

Fig. 8 depicts a preferred embodiment of the present device that includes three measurement areas. For a PT test, measurement area 146 contains thromboplastin.

Preferably, measurement areas 146A and 146B contain controls, more preferably, the controls described below. Area 146A contains thromboplastin, bovine eluate, and recombinant Factor VIIa. The composition is selected to normalize the clotting time of a blood sample by counteracting the effect of an anticoagulant, such as warfarin. Measurement area 146B contains thromboplastin and bovine eluate alone, to partially overcome the effect of an anticoagulant. Thus, three measurements are made on the strip. PT time of the sample, the measurement of primary interest, is measured on area 146. However, that measurement is validated only when measurements on areas 146A and 146B yield results within a predetermined range. If either or both of these control measurements are outside the range, then a retest is indicated. Extended stop junction 148 stops flow in all three measurement areas. Stop junction 156, in bypass channel 152, functions as described above.

Additional details on this embodiment of the invention appear in copending U.S. Patent Application Serial No. 09/333,765, filed on June 15, 1999, and incorporated herein by reference.

I Claim

1. A medical diagnostic device for measuring an analyte concentration or property of a biological fluid; comprising

- 5 a) a sample inlet for introducing a sample of the biological fluid into the device;
- b) a first capillary channel for conveying the sample from the inlet to a branching point;
- 10 c) a capillary connecting channel for conveying a first part of the sample from the branching point through a measurement area, in which is measured a physical parameter of the sample that is related to the analyte concentration or property of the fluid, and to a first stop junction;
- d) a capillary bypass channel for conveying a second part of the sample in a first direction from a first region, proximate to the branching point, to an overflow region, distal to the branching point, the first region having a capillary dimension in a second direction substantially perpendicular to the first direction;
- 15 e) a second stop junction in the bypass channel, comprising a boundary region that
- i) separates the first and overflow regions,
- 20 ii) has a second predetermined dimension in the second direction that is greater than the capillary dimension, and
- iii) forms an angle that points toward the first region, whereby any excess sample that enters the sample inlet will pass through the second stop junction into the overflow region.

25

2. The device of claim 1, further comprising a suction device, in fluid communication with the first and second stop junction, for drawing sample from the sample inlet toward stop junctions.

30

3. The device of claim 2, in which the device comprises a first layer and second layer, at least one of which has a resilient region over at least a part of its area, separated by an intermediate layer, and in which

- a) cutouts in the layers form, with the layers, the sample inlet, first channel, connecting channel, measurement area, and bypass channel;
- 35 b) the suction device comprises a bladder that

- 5 i) is distal from the sample inlet,
 ii) comprises at least a part of the resilient region, and
 iii) has a volume that is at least about equal to the combined
 volume of the first channel, measurement area, connecting channel, and
 bypass channel, and
 c) the first and second stop junctions comprise coinciding holes in
 the first, second, and intermediate layers that are sandwiched by a third layer
 and fourth layer.
- 10 4. The device of claim 3 in which at least the first or second layer is substantially
transparent adjoining the measurement area, and the physical parameter that is
measured is optical transmission.
- 15 5. The device of claim 3 in which the physical parameter of the sample undergoes
a change in the measurement area.
- 20 6. The device of claim 5 in which the measurement area contains a composition
that facilitates blood clotting, the biological fluid is whole blood, and the property
being measured is prothrombin time.
- 25 7. The device of claim 6 in which the composition comprises thromboplastin.
8. The device of claim 6 further comprising at least 20 one additional fluidic path
from the branching point to the bladder, each such alternate path including a
25 corresponding measurement area and stop junction.
- 30 9. The device of claim 8 in which a first alternate path is to a measurement area
that overcomes the effect of an anticoagulant and a second alternate path is to a
measurement area that partially overcomes the effect of an anticoagulant
- 35 10. The device of claim 9 in which the measurement area in the first alternate path
comprises thromboplastin, bovine eluate, and recombinant Factor VIIa and the
measurement area in the second alternate path comprises thromboplastin and bovine
eluate.

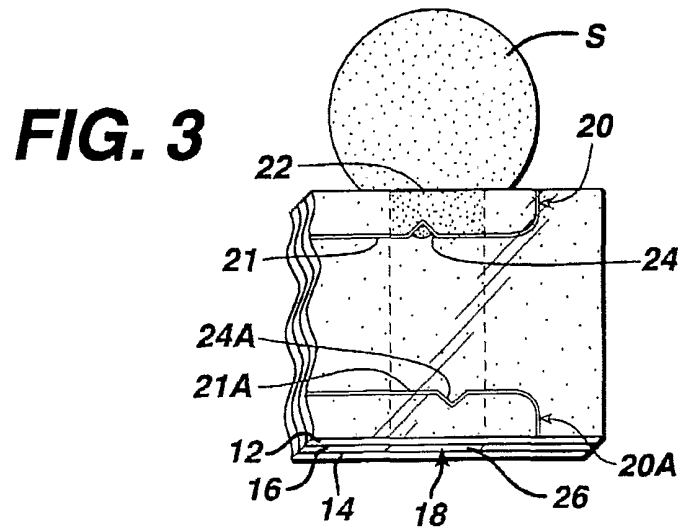
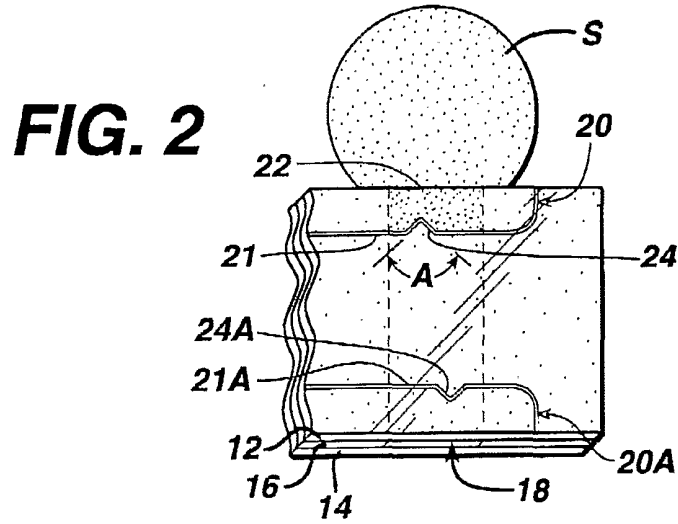
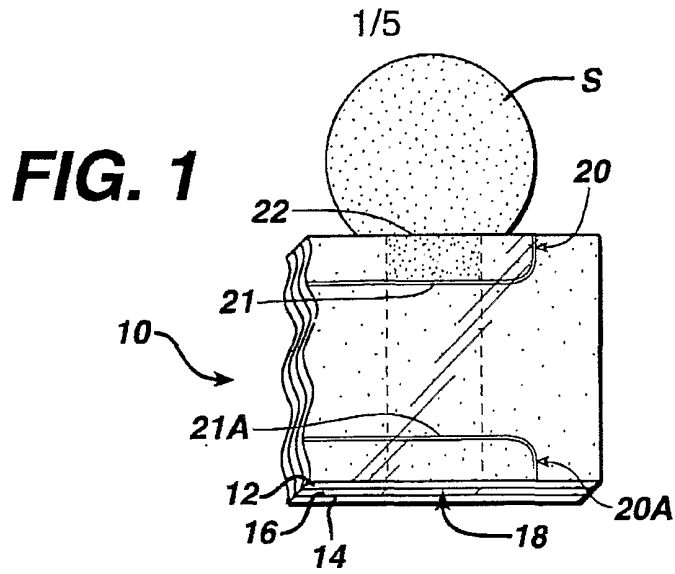

FIG. 4

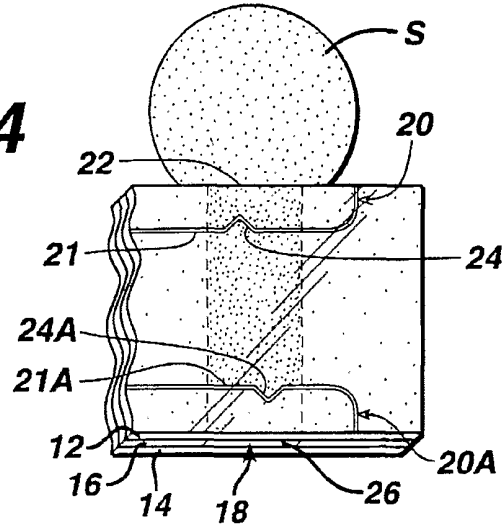

FIG. 5

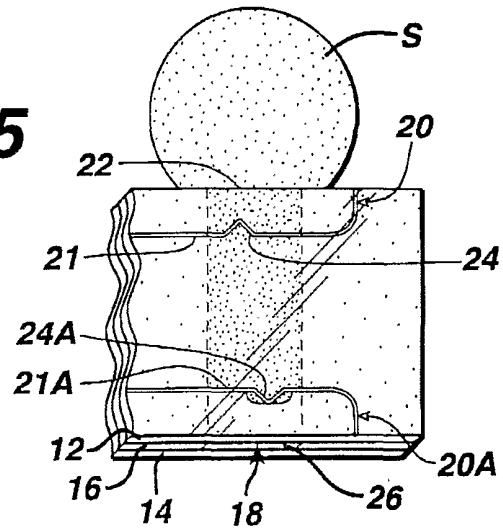

FIG. 6

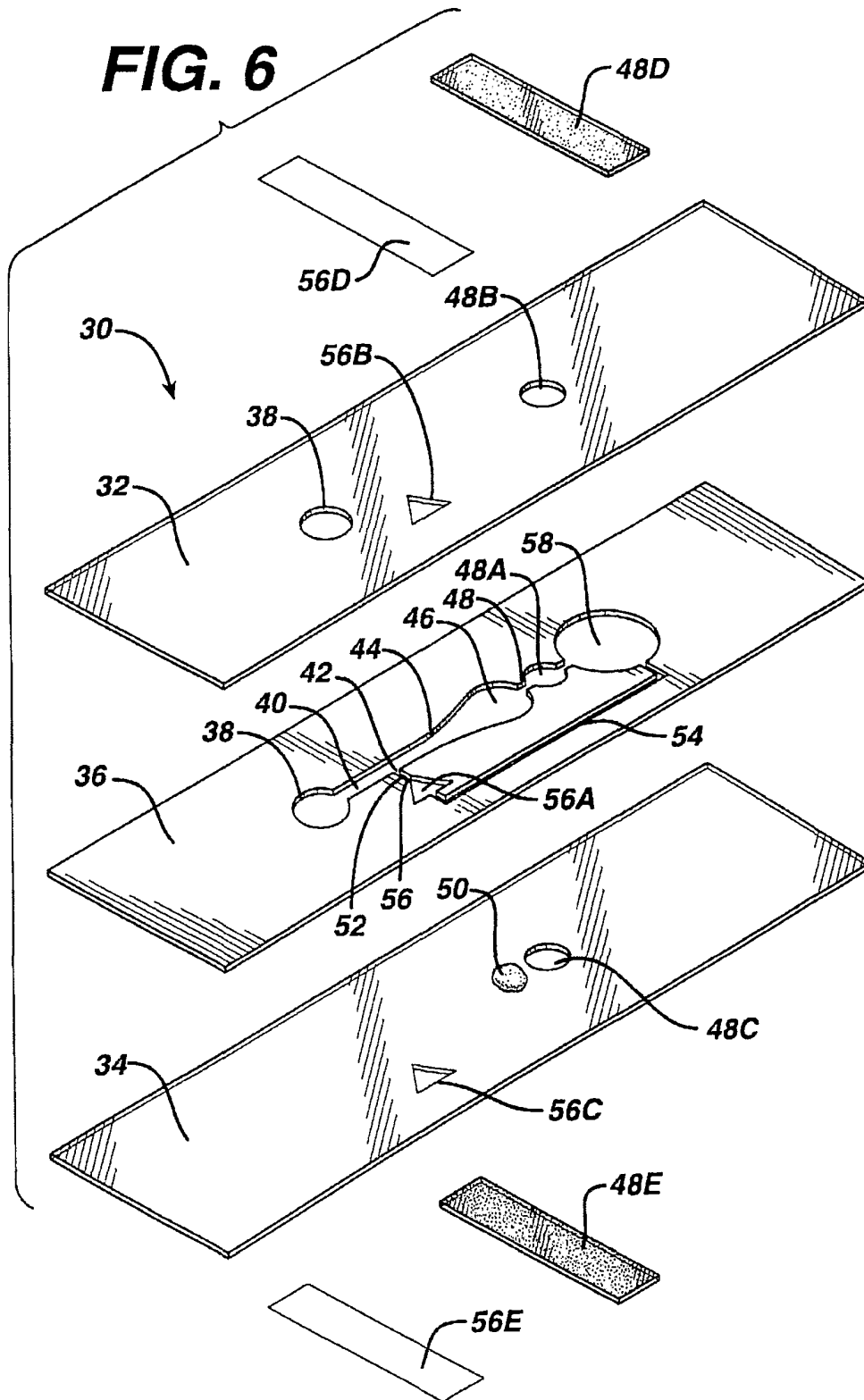

FIG. 7

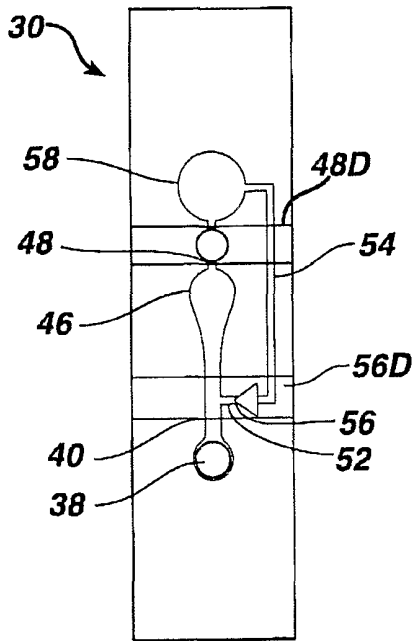

FIG. 7A

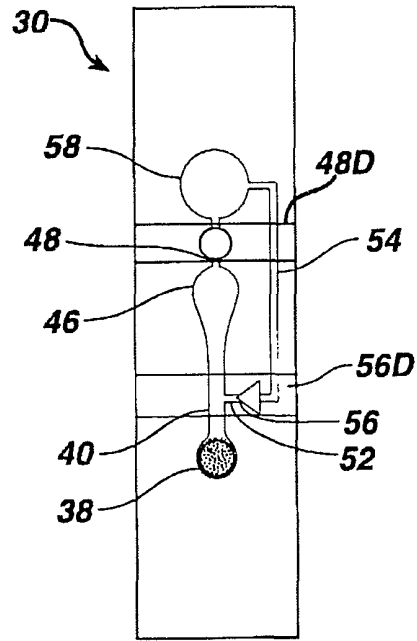

FIG. 7B

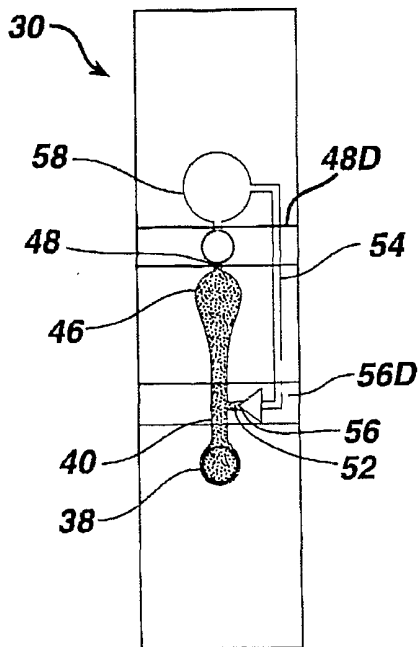

FIG. 7C

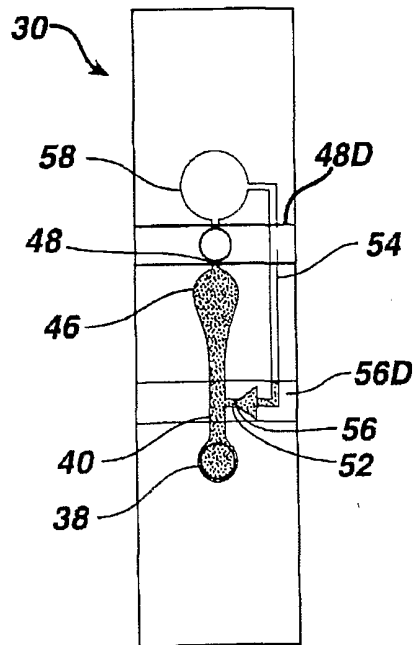

FIG. 8

