

(19) World Intellectual Property Organization
International Bureau



(43) International Publication Date
28 April 2011 (28.04.2011)

(10) International Publication Number
WO 2011/050268 A1

- (51) International Patent Classification:
G02B 5/30 (2006.01) *G02F 1/1335* (2006.01)
- (21) International Application Number:
PCT/US2010/053751
- (22) International Filing Date:
22 October 2010 (22.10.2010)
- (25) Filing Language: English
- (26) Publication Language: English
- (30) Priority Data:
61/254,691 24 October 2009 (24.10.2009) US
- (71) Applicant (for all designated States except US): **3M INNOVATIVE PROPERTIES COMPANY** [US/US]; 3M Center, Post Office Box 33427, Saint Paul, MN 55133-3427 (US).
- (72) Inventor; and
- (75) Inventor/Applicant (for US only): **WEBER, Michael, F.** [US/US]; 3M Center, Post Office Box 33427, Saint Paul, MN 55133-3427 (US).
- (74) Agents: **MOSHREFZADEH, Robert, S.** et al.; 3M Center Office of Intellectual Property Counsel, Post Office Box 33427, Saint Paul, MN 55133-3427 (US).
- (81) Designated States (unless otherwise indicated, for every kind of national protection available): AE, AG, AL, AM, AO, AT, AU, AZ, BA, BB, BG, BH, BR, BW, BY, BZ, CA, CH, CL, CN, CO, CR, CU, CZ, DE, DK, DM, DO, DZ, EC, EE, EG, ES, FI, GB, GD, GE, GH, GM, GT, HN, HR, HU, ID, IL, IN, IS, JP, KE, KG, KM, KN, KP, KR, KZ, LA, LC, LK, LR, LS, LT, LU, LY, MA, MD, ME, MG, MK, MN, MW, MX, MY, MZ, NA, NG, NI, NO, NZ, OM, PE, PG, PH, PL, PT, RO, RS, RU, SC, SD,

[Continued on next page]

(54) Title: IMMERSED REFLECTIVE POLARIZER WITH HIGH OFF-AXIS REFLECTIVITY

(57) Abstract: A film construction (320) includes a broad band reflective polarizing film (312) that may be immersed in an ultra low refractive index medium (322, 324). The reflecting polarizing film is characterized by a pass axis and a block axis, and its reflectivity for white light of the pass state polarization increases with increasing incidence angle to provide a compressed or narrowed viewing cone in one or two planes.

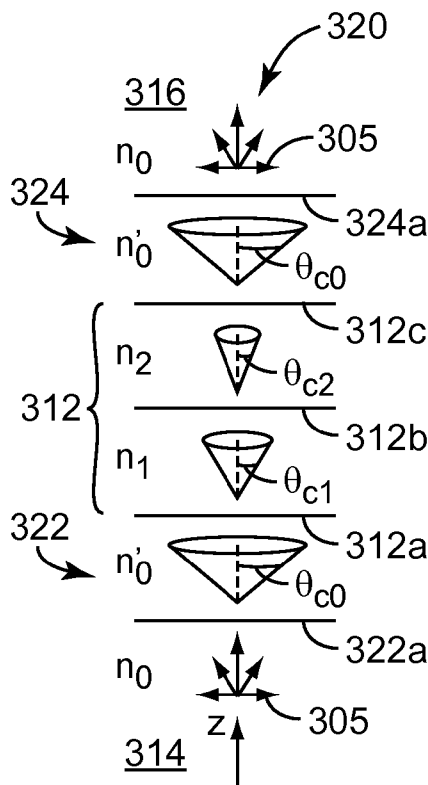

Fig. 3b

WO 2011/050268 A1



SE, SG, SK, SL, SM, ST, SV, SY, TH, TJ, TM, TN, TR, TT, TZ, UA, UG, US, UZ, VC, VN, ZA, ZM, ZW.

— as to applicant's entitlement to apply for and be granted a patent (Rule 4.17(ii))

(84) Designated States (unless otherwise indicated, for every kind of regional protection available): ARIPO (BW, GH, GM, KE, LR, LS, MW, MZ, NA, SD, SL, SZ, TZ, UG, ZM, ZW), Eurasian (AM, AZ, BY, KG, KZ, MD, RU, TJ, TM), European (AL, AT, BE, BG, CH, CY, CZ, DE, DK, EE, ES, FI, FR, GB, GR, HR, HU, IE, IS, IT, LT, LU, LV, MC, MK, MT, NL, NO, PL, PT, RO, RS, SE, SI, SK, SM, TR), OAPI (BF, BJ, CF, CG, CI, CM, GA, GN, GQ, GW, ML, MR, NE, SN, TD, TG).

— as to the applicant's entitlement to claim the priority of the earlier application (Rule 4.17(iii))

Published:

— with international search report (Art. 21(3))

— before the expiration of the time limit for amending the claims and to be republished in the event of receipt of amendments (Rule 48.2(h))

Declarations under Rule 4.17:

IMMERSED REFLECTIVE POLARIZER WITH HIGH OFF-AXIS REFLECTIVITY

FIELD OF THE INVENTION

5 This invention relates generally to optical films whose reflection and transmission characteristics are determined in large part by constructive and destructive interference of light reflected from interfaces between microlayers within the film, with particular application to combinations of such films with other components, such as components suitable for use in display systems. The invention also relates to associated articles,
10 systems, and methods.

BACKGROUND

 Reflective polarizers composed of a plurality of microlayers whose in-plane refractive indices are selected to provide a substantial refractive index mismatch between adjacent microlayers along an in-plane block axis and a substantial refractive index match
15 between adjacent microlayers along an in-plane pass axis, with a sufficient number of layers to ensure high reflectivity for normally incident light polarized along the block axis while maintaining low reflectivity and high transmission for normally incident light polarized along the pass axis, have been known for some time. See, e.g., U.S. Patent Nos.
20 3,610,729 (Rogers), 4,446,305 (Rogers et al.), and 5,486,949 (Schrenk et al.).

 More recently, researchers from 3M Company have pointed out the significance of layer-to-layer refractive index characteristics of such films along the direction perpendicular to the film, i.e. the z-axis, and shown how these characteristics play an important role in the reflectivity and transmission of the films at oblique angles of
25 incidence. See, e.g., U.S. Patent 5,882,774 (Jonza et al.). Jonza et al. teach, among other things, how a z-axis mismatch in refractive index between adjacent microlayers, more briefly termed the z-index mismatch or Δn_z , can be tailored to allow the construction of multilayer stacks for which the Brewster angle – the angle at which reflectance of p-polarized light at an interface goes to zero – is very large or is nonexistent. This in turn
30 allows for the construction of multilayer mirrors and polarizers whose interfacial reflectivity for p-polarized light decreases slowly with increasing angle of incidence, or is independent of angle of incidence, or increases with angle of incidence away from the

normal direction. As a result, multilayer films having high reflectivity for both s- and p-polarized light for any incident direction in the case of mirrors, and for the selected direction in the case of polarizers, over a wide bandwidth, can be achieved.

5

BRIEF SUMMARY

We have developed optical films capable of exhibiting reflective polarizer-like characteristics for normally incident light and high reflectivity mirror-like characteristics for obliquely incident light. These characteristics can be provided for broadband light, e.g., visible light extending over the visible spectrum. Moreover, the films desirably exhibit these characteristics even when used in laminated constructions wherein the film is joined to another optical component or components with no air gap, such that the film is “immersed” in a material of refractive index greater than 1 and light can propagate through the film at supercritical angles, i.e., angles that are more oblique than the critical angle for air. One component of such a construction is preferably an optically thick “ultra low index” (ULI) layer. The ULI layer may have a refractive index over visible wavelengths in a range from 1.1 to 1.3, or from 1.15 to 1.25, for example. The construction may include other optical components such as a diffuser, light guide, and/or display panel, or elements thereof.

Such an optical film and laminated construction may, if desired, be used in a display to selectively transmit broadband light traveling in an axial or near-axial direction and having a pass state polarization, while substantially reflecting broadband light of the pass state traveling at highly oblique angles, and reflecting broadband light having a block state polarization traveling at any angle, over a large area. Confining transmitted light of the pass state to a relatively narrow or compressed cone of propagation angles corresponding to axial or near-axial directions can advantageously be used to enhance axial brightness and contrast ratio of the display, particularly when the film or laminate is used in a recycling cavity or system such that at least some of the reflected light, whether of the pass state or block state, can be reflected by another component and converted to axial or near-axial light of the pass state.

Combining one or more optical film with other display components in a laminated construction can be advantageous for display manufacturers and suppliers in a number of ways, e.g., accelerating and simplifying the manufacturing process, reducing inventory,

and reducing cost. However, eliminating the air layer that normally contacts the major surfaces of an optical film, and replacing that air layer with other optical media in which the optical film becomes “immersed”, can pose design challenges. Snell’s law no longer operates to prevent the propagation of light through the film at supercritical angles. An
5 ultra low index (ULI) coating or other optically thick layer can approximate an air gap, but such a layer still effectively allows light to propagate a range of supercritical angles

The present application therefore discloses, *inter alia*, a film construction that includes a plurality of microlayers and an optically thick low index layer. The plurality of microlayers can be configured to selectively transmit and reflect light as a function of
10 angle and polarization over an extended wavelength region including visible wavelengths, the microlayers defining a pass axis for normally incident visible light of a first polarization and a block axis for normally incident visible light of a second polarization. The microlayers are also preferably characterized by increased reflectivity at oblique angles so as to transmit visible light of the first polarization in a compressed viewing cone.
15 The optically thick low index layer preferably has an ultra low refractive index, e.g., from 1.1 to 1.3, or from 1.15 to 1.25, and is coupled to the microlayers in such a way as to limit propagation of highly oblique light in the microlayers (e.g. in cases where the low index layer is disposed between the microlayers and the source of highly oblique light), or to redirect such highly oblique propagating light back towards the microlayers (e.g. in cases
20 where the microlayers are disposed between the low index layer and the source of highly oblique light).

The application also discloses a film construction that includes a multilayer optical film, and an optically thick low index layer attached to the multilayer optical film. The optical film is preferably configured to operate substantially as a reflective polarizer for
25 visible light at normal incidence and to operate substantially as a mirror for visible light at oblique angles. The optically thick low index layer is preferably characterized by an ultra low refractive index, e.g., a refractive index in a range from 1.1 to 1.3, or from 1.15 to 1.25, for example, for visible wavelengths.

Related methods, systems, and articles are also discussed.

30 These and other aspects of the present application will be apparent from the detailed description below. In no event, however, should the above summaries be

construed as limitations on the claimed subject matter, which subject matter is defined solely by the attached claims, as may be amended during prosecution.

BRIEF DESCRIPTION OF DRAWINGS

5 FIG. 1 is a schematic side view of a display system;

FIG. 2 is a schematic side view of the system of FIG. 1 which has been modified by the addition of laminates and/or films as disclosed herein;

10 FIGS. 3a-c are a series of schematic side views of a simplified layered film to which other layers are applied, demonstrating the concept of immersing the film in a given optical medium;

FIG. 4 is a perspective view of the angular range, or cone, of light propagation in a given layer, illustrating the widening of the cone when the layer is immersed in a medium other than air;

FIG. 5 is a schematic perspective view of a portion of a multilayer optical film;

15 FIG. 6 is a schematic perspective view of a reflective polarizing film;

FIG. 7a is a perspective view of a direction hemisphere, wherein any point on the hemisphere represents a direction of light propagation in a film, characterized by a polar angle θ and an azimuthal angle ϕ ;

20 FIG. 7b is a perspective view of the direction hemisphere of FIG. 7a, showing in simplified fashion transmission properties of a 2-axis collimating multilayer reflective polarizing film as disclosed herein, for light having the pass state polarization;

FIG. 7c is a perspective view similar to that of FIG. 7b, but showing in simplified fashion transmission properties of a 1-axis collimating multilayer reflective polarizing film, for light having the pass state polarization;

25 FIG. 8a is a graph of calculated internal reflectivity for a multilayer reflective polarizing film that is immersed in an ultra low index medium, as a function of incidence angle in the ultra low index medium;

30 FIG. 8b is a graph of the calculated wavelength of the right band edge for the film of FIG. 8a, as a function of incidence angle in the ultra low index medium for both block state polarized light and pass state polarized light, and for both s- and p-polarization components in each case;

FIG. 9 is a graph of layer-to-layer refractive index differences along two orthogonal directions for certain multilayer optical films;

FIGS. 10 and 11 are graphs of calculated internal reflectivity for additional multilayer reflective polarizing films that are immersed in an ultra low index medium, as a function of incidence angle in such medium;

FIGS. 12 and 13 are schematic side views of laminate constructions that incorporate at least one optically thick ultra low index layer and a multilayer reflective polarizing film as disclosed herein;

FIG. 14 is a schematic front or top view of the laminate construction of FIG. 13;

FIG. 15 is a schematic side view of a laminate construction that includes a display panel and a multilayer reflective polarizing film;

FIGS. 16-18 are schematic side views of laminate constructions that include a display panel, a multilayer reflective polarizing film, and an optically thick ultra low index layer;

FIG. 19 is a schematic side view of a laminate construction that includes a light guide, a multilayer reflective polarizing film, and an optically thick ultra low index layer;

FIGS. 20a-b are graphs of transmission versus wavelength data for a film example;

FIG. 21 is a graph of transmission versus wavelength for another film example;

FIG. 22 is a schematic side view of a combined display panel/backlight laminate;

FIGS. 23a-j are plots of contrast and brightness for various laminate embodiments;

and

FIG. 24 is a graph of summary information for four different film samples.

In the figures, like reference numerals designate like elements.

DETAILED DESCRIPTION OF ILLUSTRATIVE EMBODIMENTS

Most optical films that are suitable for use in displays, backlights, luminaires, and the like have optical transmission and reflection characteristics that change with the angle of incidence of light. Multilayer optical films, for example, which comprise a plurality of microlayers that are sufficiently thin so that some light is reflected from a plurality of the microlayer interfaces to undergo constructive or destructive interference to provide the desired reflective or transmissive properties, are specifically designed for a particular range of entrance and/or exit angles in a particular medium – typically air. Similarly,

surface structured films, such as prismatic brightness enhancement films, are also specifically designed for a particular range of entrance and/or exit angles in air. For given incidence angles in air, propagation angles and exit angles for such optical films are determined by well known formulas such as Snell's law for refraction or other formulas
5 such as those for diffractive gratings.

Many optical films used in liquid crystal display (LCD) applications are designed for use in air, i.e., light impinges from air on a first major surface of the film over a range of entrance angles, and light emerges from a second major surface of the film into air over a range of exit angles, and one or both of the entrance or exit angles cover a range from 0°
10 to 90° in air. Such a film can be said to be "optically immersed" in air. This may be true even if it is difficult for the unaided eye to observe any air layer. For example, if one optical film is laid atop another optical film, it may appear to the unaided eye that the two films are in substantial contact over their entire major surfaces. Often, however, such films contact each other only at a finite number of points, and an optically thick air gap—
15 i.e., one whose thickness is substantially greater than the wavelength of light of interest—is substantially maintained between the major surfaces of the films.

Market forces for reducing cost of LCD displays and other products, and/or for design enhancements such as reduced product thickness, may lead to a desire to identify and eliminate unnecessary components and to combine individual components into one or
20 more packaged sets. In the case of optical films, such a desire may lead to an attempt to affix or attach the optical film to one or more other films or system components to form a laminate construction, wherein substantially no air gap exists between the elements of the laminate.

FIG. 1 shows a schematic side view of a typical display system **110** that includes a
25 display assembly **112** and a backlight **114**, within the context of a Cartesian x-y-z coordinate system for ease of reference. If the system **110** is an LCD, the display assembly **112** may include a liquid crystal (LC) display panel sandwiched between a front and back absorbing polarizer, the LC display panel further including glass panel plates between which liquid crystal material is disposed with an array of electrode structures and
30 a color filter grid to form individually addressable picture elements (pixels). A controller **116** couples to the display assembly **112** via connection **116a** to drive the electrode structures appropriately to produce a suitable image that can be perceived by an observer

118. The backlight **114** may be of the “edge lit” variety, in which case one or more LEDs, cold cathode fluorescent lamps (CCFLs), or other suitable light sources **120a**, **120b** are positioned along one or more edges or borders of the backlight, outside of the viewing area thereof. Alternatively, the backlight may be of the “direct lit” variety, in which case one or more such light sources **120c**, **120d**, **120e** may be positioned in the viewing area behind a diffuser plate or other suitable element. In any event, the backlight **114** provides light over a large output area **114a** corresponding to the viewing area of the display assembly **112**. The light provided by the backlight is typically white, i.e., it includes an appropriate balance of red, green, and blue spectral components (or other suitable mix of spectral components) so that it appears at least nominally white to an observer.

The display system **110** also typically includes one or more optical films or other components between the display assembly **112** and the backlight **114** or elsewhere in the system. Depending on the type of display system, such components may include one or more polarizer (including e.g. absorptive polarizers and/or reflective polarizers), diffuser (including e.g. diffuser plates, gain diffusers, volume diffusers, and/or surface diffusers), and/or prismatic brightness enhancement film (including e.g. any of the wide variety of Vikuiti™ BEF products offered by 3M Company, St. Paul, Minnesota, USA), for example. Such films are often used to enhance the efficiency and/or brightness of the display system by reflecting “unusable light” (i.e., light that would not contribute to the desired system output, whether because it is of a polarization that would be absorbed by a rear absorbing polarizer in the display assembly **112** or because it is propagating at an unsuitable angle) away from the display assembly, and then redirecting some of that reflected light back towards the display assembly as “useable light” (i.e., light that can contribute to the system output) via a diffuse, specular, or semi-specular reflector, for example. Such reflection and re-direction of the light provides for at least some degree of light recycling in the display system, which recycling is indicated generally by arrows **122a**, **122b**.

The films and components normally located between the display assembly **112** and backlight **114**, or disposed elsewhere, are candidates for use in the laminate constructions discussed above that are devoid of air gaps. Such laminate constructions are depicted generally in the display system **210** of FIG. 2. Except for the laminate constructions, the system **210** may be substantially identical to the system **110** of FIG. 1 including its various

permutations discussed above, and like reference numerals are used to refer to like elements with no further description provided for brevity. The display system of FIG. 2, however, joins one or more optical films to other films or components with no air gap to provide one or more laminates **212a**, **212b**, **212c** as shown. In the figure, laminate **212a** attaches to the display assembly **112** (or a component thereof) with no air gap, and laminate **212c** attaches to the backlight **114** (or a component thereof) with no air gap. In some cases, a laminate **212b** may be provided that attaches one or more optical films to other film(s) or component(s) with no air gap therebetween, but that may be spaced apart from both the display assembly and the backlight via an air gap.

Depending on the types of optical films to be included in the laminates, the elimination of an air interface or air gap may or may not pose a problem for the operation of the optical film. In cases where each film or component to be joined does not substantially scatter or otherwise redirect light in the process of entering or after it enters one major surface and before it exits the other major surface of the film, the film may continue to function as it did before lamination, i.e., before elimination of the air gap. However, when the light enters the film through a non-planar surface, or through a surface that is not parallel to the film, the film may not function properly. One example of this is BEF prisms coated onto Vikuiti™ DBEF multilayer reflective polarizing film. Both the BEF prismatic film and the DBEF film are designed for use in air, but no loss of functionality occurs when the air gap is eliminated by optically coupling the planar surfaces of both films with e.g. an optical adhesive. Another example is a Vikuti™ DBEF film laminated to an absorbing polarizer film. In both of these examples, the elimination of the air gap does not substantially affect the angular distribution of light that propagates through the affected films. Stated differently, each optical film in the laminate construction can said to be optically immersed in air, even though its major surfaces may not be in contact with air. This is explained further below in connection with FIGS. 3a-c.

In other cases, at least one film or component that generates highly oblique light is provided in the laminate, and the elimination of the air gap in combination with such highly oblique light has the effect of causing “supercritical” light to propagate through an optical film of interest and exit the laminate in such a way as to degrade system performance. By “supercritical” light we mean light that travels through the film at an angle that is more oblique than can be achieved by illumination from air using a flat,

smooth air/film interface. Thus, when a film is optically immersed in air, the maximum angle of incidence for light impinging on the major surface of the film from air is 90 degrees. Such grazing incidence light is refracted into the film at the critical angle, θ_c , which is a function of the refractive index of the film. The critical angle is typically the most oblique angle at which light would propagate within the film. For laminate constructions that allow supercritical light to propagate through the optical film and eventually emerge from the laminate construction, the optical film can be said to be optically immersed in a medium of higher refractive index than air. This is explained further below in connection with FIG. 3c. In the context of the present application, a film or component that is described as being “optically immersed” is assumed to be optically immersed in a medium whose refractive index is greater than that of air, unless otherwise indicated.

Such a situation can occur when laminating a BEF prismatic film to the diffuser plate of a backlight, or to an LCD panel, for example, using a conventional optical adhesive having an index of refraction near 1.5. In both cases the entrance and exit angles for the BEF film are dramatically affected by the refractive index of the laminating adhesive, which is significantly different from that of air. This situation can also occur when a diffuser is laminated with a conventional optical adhesive to one side of a reflective polarizer, the other side of which is then laminated to an LCD panel. In this case the optical adhesive transmits highly oblique light produced within the diffuser into the reflective polarizer as supercritical light, which may be further transmitted into the LCD panel. Since neither the reflective polarizer nor the LCD panel are typically designed to accommodate such highly oblique light, this can result in degraded performance by the polarizer and large amounts of internally scattered light within the LCD panel, which in turn may result in much lower display contrast and brightness. Even if the reflective polarizing film is redesigned to handle a larger range of incidence angles, such as by substantially widening the already broad reflection band of a multilayer stack reflective polarizer (e.g. by increasing the number of microlayers and extending the upper limit of the thickness gradient that characterizes the microlayers), such a redesigned film will continue to transmit the pass axis polarization of light through the larger ranges of angles and the problems cited will remain unsolved.

In order to minimize problems associated with supercritical light propagation in laminate constructions, it would be desirable to utilize a material layer that, from an optical design standpoint, resembles an air gap as closely as possible, e.g., a material layer that is both highly transmissive to light for light paths that are optically thick, and whose refractive index is close to 1.0. Stated differently, there is a need for a means to physically attach transmissive optical components in a surface-to-surface mode while still restricting the angles of entrance and exit to those comparable to air. Ultra-low index films with good mechanical integrity and low haze have recently been developed. Such films can be coated onto almost any optical film, so as to approximate an air gap, and then any conventional optical adhesive can be applied to join the coated film with another component in the system. Suitable ultra low index materials are described in, for example, the following U.S. patent applications which are incorporated herein in their entireties by reference: "Optical Film" (Attorney Docket No. 65062US002 filed on April 15, 2009 and having Serial No. 61/169466; "Optical Construction and Display System Incorporating Same" (Attorney Docket No. 65354US002) filed on April 15, 2009 and having Serial No. 61/169521; "Retroreflecting Optical Construction" (Attorney Docket No. 65355US002) filed on April 15, 2009 and having Serial No. 61/169532; "Optical Film for Preventing Optical Coupling" (Attorney Docket No. 65356US002) filed on April 15, 2009 and having Serial No. 61/169549; "Backlight and Display System Incorporating Same" (Attorney Docket No. 65357US002) filed on April 15, 2009 and having Serial No. 61/169555; "Process and Apparatus for Coating with Reduced Defects" (Attorney Docket No. 65185US002) filed on April 15, 2009 and having Serial No. 61/169427; "Process and Apparatus for A Nanovoiced Article" (Attorney Docket No. 65046US002) filed on April 15, 2009 and having Serial No. 61/169429; and "Optical Construction and Method of Making the Same" (Attorney Docket No. 65619US002) filed on October 22, 2009 and having Serial No. 61/254,243. Ultra-low index materials can also be made using a gel type of fumed silica. The ultra-low index material may have a refractive index over visible wavelengths in a range from 1.1-1.3, or from 1.15 to 1.25, for example. As discussed further below, the ultra-low index material may also exhibit a gradient in refractive index. For example, the material may be in the form of a gradient film or layer comprising a binder and a plurality of particles, wherein a weight ratio of the binder to the plurality of the particles is not less than about 1:2. The gradient optical film may further

include a plurality of interconnected voids having a local volume fraction, wherein the local volume fraction of the plurality of interconnected voids varies along a thickness direction of the film so as to provide a local refractive index within the film that changes along such thickness direction. Reference is made to U.S. patent application serial no. 5 XX/XXX,XXX, "GRADIENT LOW INDEX ARTICLE AND METHOD" (Attorney Docket No. 65716US002), and U.S. patent application serial no. XX/XXX,XXX, "PROCESS FOR GRADIENT NANOVOIDED ARTICLE" (Attorney Docket No. 65766US002), both filed on even date herewith and incorporated herein by reference.

Such ultra-low refractive index materials can be used in laminates that include 10 angle-sensitive optical films so that such films can be mechanically and optically coupled to other films or components while minimizing the deleterious effects of supercritical light propagation. However, even when using one or more such ultra-low index material layer in a laminate construction, the effects of supercritical light propagation can still play an important part in system performance, and indeed can substantially degrade system 15 performance unless design aspects of the multilayer optical film(s) and/or of other angle-sensitive optical films are properly handled.

Before discussing specific design considerations for multilayer reflective polarizing films used in laminates that support supercritical light propagation, we turn to FIGS. 3a-c to illustrate the concept of optically immersing a film in a medium other than 20 air.

FIGS. 3a-c are a series of schematic side views of a simplified layered film to which other layers are applied, demonstrating the concept of immersing the film in an optical medium. In FIG. 3a, an elementary film construction **310** consists essentially of a layered film **312** exposed on both sides to a medium of refractive index n_0 , which is 25 assumed to be air ($n_0 = 1.0$). For ease of discussion, n_0 and the other refractive indices shown in these FIGS. 3a-c are assumed to be isotropic. Furthermore, the film **312** is illustrated as having only two layers: a first layer of a conventional low refractive index optical material, such as a polymer whose refractive index n_1 is of the order of 1.5 or above; and a second layer of a conventional higher refractive index optical material, such 30 as a different polymer whose refractive index n_2 is also of the order of 1.5 or above, but n_2 is substantially greater than n_1 . The film **312** has a first major surface **312a**, a surface or interface **312b** that separates the first and second layers, and a second major surface **312c**.

The surface **312a** is exposed to a thick layer **314** of air, and the surface **312c** is exposed to another thick layer **316** of air.

Still referring to FIG. 3a, light is incident on the film **312** from below, i.e., from the layer **314** of air. The incident light travels roughly along the depicted z-axis, which may be perpendicular to the thickness dimension of the film **312**, but the incident light includes the widest possible range of light ray propagation directions, including rays directed parallel to the z-axis, rays directed at moderate oblique angles to the z-axis, and rays directed at extreme oblique angles that are virtually perpendicular to the z-axis such that they strike surface **312a** at glancing incidence. This widest possible range of incidence angles is represented by the 5-headed arrow symbol **305**. In some cases the light distribution associated with symbol **305** may be quasi-Lambertian, while in others it may have a very different distribution. In any case the light distribution of symbol **305** includes some amount of light traveling in all directions over a hemisphere (or 2π solid angle) of possible paths. We now follow this incident light as it passes from the air layer **314**, through the film **312**, to the opposite air layer **316**. In doing so, we concentrate on refraction at the various interfaces and, for simplicity, ignore reflection.

The surfaces **312a**, **312b**, **312c** are all assumed to be flat and smooth, and perpendicular to the z-axis. Thus, when the incident light from the air layer **314** impinges on the major surface **312a**, it refracts into the first layer of the film **312** according to Snell's law, i.e., $n_0 \sin\theta_0 = n_1 \sin\theta_1$. Since the incident light contains light rays whose incident angle ranges from $\theta_0 = 0$ to $\theta_0 \approx 90$ degrees, the refracted light will contain refracted light rays whose refracted angle, or angle of propagation, ranges from $\theta_1 = 0$ to $\theta_1 = \theta_{c1}$, where θ_{c1} is the critical angle for the material of the first layer, i.e., $\theta_{c1} = \arcsin(1/n_1)$, since $\sin(90) = 1$ and $n_0 = 1$. The collection of all refracted rays in the first layer is represented by the cone whose half-angle is θ_{c1} .

The refracted light advances generally along the z-axis and encounters the surface or interface **312b**, where a second refraction occurs as the light enters the second layer, whose refractive index is n_2 . The second refraction again follows Snell's law, producing refracted light within the second layer over a range of propagation directions or angles θ_2 , where θ_2 ranges from $\theta_2 = 0$ to $\theta_2 = \theta_{c2}$. The angle θ_{c2} is the critical angle for the material of the second layer, i.e., $\theta_{c2} = \arcsin(1/n_2)$. The collection of all refracted rays in the second layer is represented by the cone whose half-angle is θ_{c2} . Since the refractive index

n_2 was assumed to be greater than refractive index n_1 , the angle θ_{c2} is shown as being smaller than θ_{c1} .

The refracted light in the second layer advances further until it encounters the major surface **312c**. Here, another refraction occurs as the light passes from the second layer into the air layer **316**. Again in accordance with Snell's law, the range of propagation angles θ_2 for light in the second layer is transformed by refraction into a range of propagation angles for the air layer **316** that ranges from 0 to substantially 90 degrees, indicated again by symbol **305**. Thus, in the process of traversing the film **312**, hemispherically incident light from air is converted into conical distributions of light in the different material layers of the film, and then back again into hemispherically propagating light in the other air layer. The half-angle of the conical distributions in the material layers equals the critical angle of the respective material.

Turning now to FIG. 3b, we see there a schematic side view of another film construction **320**. Film construction **320** includes the two-layered film **312** from FIG. 3a, but adds to it one layer of ultra low index material, having refractive index n_0' , on each side of the film **312** to produce the construction **320**. The index n_0' is greater than air but substantially less than the low index n_1 . A first layer **322** of the index n_0' material is applied to the surface **312a** of the film **312**, and a second layer **324** of the index n_0' material is applied to the surface **312c** of the film **312**. The original film **312** in combination with the layers **322**, **324** now form a new film having flat, smooth major surfaces **322a**, **324a** exposed to air, the surfaces **322a**, **324a** being parallel to the surfaces **312a-c**.

Still referring to FIG. 3b, light is incident on the construction **320** from below, i.e., from the layer **314** of air. As in FIG. 3a, the incident light travels roughly along the z-axis but with rays spanning the widest possible range of incidence angles, again represented by the 5-headed arrow symbol **305**. We follow this incident light as it passes from the air layer **314**, through the different layers of the construction **320**, to the opposite air layer **316**.

When the incident light from the air layer **314** impinges on the major surface **322a**, it refracts into the layer **322** of ultra-low index material according to Snell's law, i.e., $n_0 \sin\theta_0 = n_0' \sin\theta_0'$. Since the incident light contains light rays whose incident angle ranges from $\theta_0 = 0$ to $\theta_0 \approx 90$ degrees, the refracted light contains refracted light rays whose

refracted angle, or angle of propagation, ranges from $\theta_0' = 0$ to $\theta_0' = \theta_{c0}$, where θ_{c0} is the critical angle for the ultra-low index material, i.e., $\theta_{c0} = \arcsin(1/n_0')$. The collection of all refracted rays in the layer **322** is represented by the cone whose half-angle is θ_{c0} .

This refracted light then advances through the remainder of the construction **320**.
 5 As it does so, the cone of angles representing the range of propagation directions in each of the distinct layers is determined by Snell's law. In a straightforward manner, one can readily deduce that the half-angle of the cone of propagation directions changes from θ_{c0} to θ_{c1} to θ_{c2} to θ_{c0} as light advances from layer **322** to layer **324**, as shown in FIG. 3b. Light that refracts from layer **324** into the air layer **316** is again refracted into the widest
 10 possible range of propagation angles **305**.

Comparing FIGS. 3a and 3b, we see that the addition of the layers **322**, **324** to the film **312** does nothing to change the range of propagation directions inside the film **312**. For each of the two layers of the film **312**, the half-angle of the propagation cone remains the same. Note that this result would be the same regardless of the refractive index used
 15 for layers **322**, **324**. Thus, despite the presence of the layers **322**, **324** between the film **312** and air, we nevertheless characterize the film **312** as still being optically immersed in air.

Turning now to FIG. 3c, here we have a film construction **330** that is substantially the same as construction **330**, except that the layers **322**, **324** are replaced with layers **332**,
 20 **334**. The layers **332**, **334** have the same ultra-low refractive index as layers **322**, **324**. However, the flat, smooth major surfaces **322a**, **324a** of FIG. 3b are replaced with roughened major surfaces **332a**, **334a**, which provide a significant diffusing effect. As a result, hemispherically distributed incident light rays impinging from the air layer **314** onto the major surface **332a** are refracted and diffused at all propagation angles (see
 25 symbol **305**) in the layer **332**, rather than being confined to a cone of half-angle θ_{c0} as was the case in FIG. 3b. This expanded range of propagation angles in layer **332** produces, via Snell's law at interface **312a**, a cone of propagation directions in the first layer of film **312** whose half-angle θ_{c1}' is substantially greater than the corresponding half-angle θ_{c1} from FIG. 3b. In particular, $\theta_{c1}' = \arcsin(n_0'/n_1)$. When this light passes into the second layer of
 30 film **312**, it refracts at surface **312b** to produce a cone of propagation directions in the second layer that is also expanded relative to the corresponding cone in FIG. 3b. The half-angle θ_{c2}' is computed according to $\theta_{c2}' = \arcsin(n_0'/n_2)$. This light is refracted at surface

312c into ultra-low index layer **334** at all angles via Snell's law, and this light in turn is refracted and diffused into the air layer **316** at all angles by virtue of the roughened major surface **334a**.

Comparing FIG. 3c with FIGS. 3a and 3b, we see that light is able to propagate at more oblique angles in the layers of film **312** in the construction **330** compared to the constructions **320**, **310**. Since light is able to impinge upon the film **312** at all angles from ultra-low index layer **332**, and since light that enters the film **312** at any such angle is able to exit the film via layers **334**, **316**, the film **312** in FIG. 3c can be said to be optically immersed in the ultra-low refractive index material of index n_0' .

FIG. 4 is a perspective view of the angular range, or cone, of light propagation in a given layer, illustrating the widening of the cone when the layer is optically immersed in a medium other than air. Thus, the half-angle of the cone **410** is the critical angle θ_c for the layer material. This is the range of possible light propagation directions when the layer is optically immersed in air. The range of light propagation directions expands to the wider cone **412**, of half angle θ_c' , if the layer is optically immersed in a medium of refractive index greater than air. The difference between these two cones, or solid angles, is represented by the differential angle θ_{gap} in FIG. 4. Light whose propagation direction lies in this gap represents light for which the layer, or the film of which it is a part, may not be designed to handle.

We now shift our attention to multilayer optical films that can be used in the disclosed laminate constructions with one or more optically thick ultra-low refractive index layers, such that the multilayer optical film can be considered to be optically immersed in the ultra-low refractive index material. We begin with a broad description of the capabilities of multilayer optical films generally, and later describe specific design characteristics that allow a multilayer optical film to be used as an optically immersed reflective polarizer with oblique angle reflecting or collimating characteristics.

FIG. 5 depicts only two layers of a multilayer optical film **500**, which would typically include tens or hundreds of such layers arranged in one or more contiguous packets. The film **500** includes individual microlayers **502**, **504**. The microlayers have different refractive index characteristics so that some light is reflected at interfaces between adjacent microlayers. The microlayers are sufficiently thin so that light reflected at a plurality of the interfaces undergoes constructive or destructive interference to give

the film the desired reflective or transmissive properties. For optical films designed to reflect light at ultraviolet, visible, or near-infrared wavelengths, each microlayer generally has an optical thickness (i.e., a physical thickness multiplied by refractive index) of less than about 1 μm . Thicker layers can, however, also be included, such as skin layers at the
5 outer surfaces of the film, or protective boundary layers disposed within the film that separate packets of microlayers.

The reflective and transmissive properties of multilayer optical film **500** are a function of the refractive indices of the respective microlayers, the total number of microlayers, and the thicknesses of the microlayers. Each microlayer can be
10 characterized, at least in localized positions in the film, by in-plane refractive indices n_x , n_y , and a refractive index n_z associated with a thickness axis of the film. These indices represent the refractive index of the subject material for light polarized along mutually orthogonal x-, y-, and z-axes, respectively (*see* FIG. 5).

In practice, the refractive indices are controlled by judicious materials selection and processing conditions. Film **500** can be made by co-extrusion of typically tens or
15 hundreds of layers of two alternating polymers A, B, followed by optionally passing the multilayer extrudate through one or more multiplication die, and then stretching or otherwise orienting the extrudate to form a final film. The resulting film is composed of typically tens or hundreds of individual microlayers whose thicknesses and refractive
20 indices are tailored to provide one or more reflection bands in desired region(s) of the spectrum, such as in the visible or near infrared. To achieve high reflectivities with a reasonable number of layers, adjacent microlayers can exhibit a difference in refractive index (Δn_x) for light polarized along the x-axis of at least 0.05, for example. If the high reflectivity is desired for two orthogonal polarizations, then the adjacent microlayers also
25 can exhibit a difference in refractive index (Δn_y) for light polarized along the y-axis of at least 0.05, for example.

If desired, the refractive index difference (Δn_z) between adjacent microlayers for light polarized along the z-axis can also be tailored to achieve desirable reflectivity properties for the p-polarization component of obliquely incident light. For ease of
30 explanation, at any point of interest on a multilayer optical film, the x-axis can be considered to be oriented within the plane of the film such that the magnitude of the in-plane Δn is a maximum. Hence, the magnitude of Δn_y may be equal to or less than (but

not greater than) the magnitude of Δn_x . Furthermore, the selection of which material layer to begin with in calculating the differences Δn_x , Δn_y , Δn_z is dictated by requiring that Δn_x be non-negative. In other words, the refractive index differences between two layers forming an interface are $\Delta n_j = n_{1j} - n_{2j}$, where $j = x, y, \text{ or } z$ and where the layer designations 1,2 are chosen so that $n_{1x} \geq n_{2x}$, i.e., $\Delta n_x \geq 0$.

To maintain near on-axis reflectivity of p-polarized light at oblique angles of incidence, the z-index mismatch Δn_z between microlayers can be controlled to be substantially less than the maximum in-plane refractive index difference Δn_x , such that $\Delta n_z \leq 0.5 * \Delta n_x$. Alternatively, $\Delta n_z \leq 0.25 * \Delta n_x$. A zero or near zero magnitude z-index mismatch yields interfaces between microlayers whose reflectivity for p-polarized light is constant or near constant as a function of incidence angle. Furthermore, the z-index mismatch Δn_z can be controlled to have the opposite polarity compared to the in-plane index difference Δn_x , i.e., $\Delta n_z < 0$. This condition yields interfaces whose reflectivity for p-polarized light increases with increasing angles of incidence, as is the case for s-polarized light.

In order to provide for a polarizing film with $T_{\text{block}}(0)$ substantially less than $T_{\text{pass}}(0)$ and to provide for a high reflectivity for both s-polarized and p-polarized light pass axis light with a reasonable number of layers, the film materials and indices can be tailored such that Δn_x is greater than about 0.1, Δn_y is greater than about 0.05, and Δn_z is less than about - 0.05.

If the thicknesses of all of the microlayers in a given multilayer film were designed to be the same, the film would provide high reflectivity over only a narrow band of wavelengths. Such a film would appear highly colored if the band were located somewhere in the visible spectrum, and the color would change as a function of angle. In the context of display applications, films that exhibit noticeable colors are generally avoided, although in some cases it may be beneficial for a given optical film to introduce a small amount of color to correct for color imbalances elsewhere in the system. Multilayer films can be provided with broad band reflectivity and transmission, e.g. over the entire visible spectrum, by tailoring the microlayers—or more precisely, the optical repeat units, which typically correspond to pairs of adjacent microlayers—to have a range of optical thicknesses. Typically, the microlayers are arranged along the z-axis or thickness direction of the film from a thinnest optical repeat unit on one side of the film or packet to

a thickest optical repeat unit on the other side, with the thinnest reflecting the shortest wavelengths in the reflection band and the longest reflecting the longest wavelengths. Further discussion of thickness gradients in multilayer optical films, including tailoring the thickness gradient to provide a sharpened band edge, is provided in U.S. Patent 6,157,490 (Wheatley et al.).

The disclosed multilayer films desirably have a reflection band of sufficient bandwidth that they reflect light of wavelengths over most of the visible spectrum at most angles in the ultra-low index (ULI) medium. The visible spectrum appropriate to many displays and luminaires extends to about 630 nm for some systems, 650 nm for others, and as high as 670 nm for some of the highest color gamut systems. Due to the high Fresnel reflectivity near 90 degrees at any ULI/polymer interface, not much light will be transmitted at these highest angles. For this reason, the right band edge (RBE) of the pass axis of the film for p-polarized light is desirably above about 650 nm at $\theta = 75$ degrees in the ULI. For an index 1.2 ULI then, the minimum RBE for the pass axis of the film is desirably at least 950 nm at normal incidence. For improved contrast and color balance in an LCD display, the RBE of the pass axis of these films for p-polarized light is desirably above 1000 nm or above 1050 nm or as high as 1100 nm at normal incidence. If the ULI has an index of 1.15, the RBE of the pass axis for p-polarized light is desirably greater than at least about 900 nm, and more desirably greater than 950 nm or even 1000 nm at normal incidence. For indices of the ULI higher than either 1.15 or 1.2, the right band edges of the films are desirably made proportionately higher.

Multilayer optical films can be manufactured using any suitable technique. Typically, manufacture involves heating polymer materials above their melting or glass transition temperatures, feeding the molten polymers into a multilayer feedblock, optionally multiplying the layers using one or more layer multipliers, sending the molten material through a film extrusion die, casting the extrudate leaving the die onto a casting wheel, and stretching or otherwise orienting the cast film along one or two film directions. See, e.g., U.S. Patent Nos. 5,882,774 (Jonza et al.) and 6,783,349 (Neavin et al.). In some embodiments, the films can be manufactured without the use of a layer multiplier. Although layer multipliers greatly simplify the generation of a large number of optical layers, they may impart distortions to each resultant packet of layers that are not identical for each packet. For this reason, any adjustment in the layer thickness profile of the layers

generated in the feedblock is not the same for each packet, i.e., all packets cannot be simultaneously optimized to produce a uniform smooth spectrum free of spectral disruptions. Thus, an optimum profile, for low transmitted and reflected color, can be difficult to make using multipacket films manufactured using multipliers. If the number of
5 layers in a single packet generated directly in a feedblock do not provide sufficient reflectivity, then two or more such films can be attached to increase the reflectivity. Further discussion of layer thickness control, so as to provide smooth spectral reflectivity and transmission for low color films, is provided in PCT publication WO 2008/144656 (Weber et al.).

10 The materials used in the manufacture of multilayer optical films are typically polymer materials that have very low absorption at least over visible and near-visible wavelengths and for typical optical path distances within the film. Thus, the % reflection R and the % transmission T of a multilayer film for a given light ray are typically substantially complementary, i.e., $R + T \approx 100\%$, usually within an accuracy of about 1%.
15 Thus, unless otherwise noted, a multilayer optical film disclosed herein as having a high reflectivity can be assumed to have a low transmission, and vice versa, and a multilayer optical film disclosed as having a low reflectivity can be assumed to have a high transmission, and vice versa, and reported values of reflectivity or transmission can be assumed to also report on transmission or reflectivity, respectively, via the relationship R
20 + T $\approx 100\%$.

Another issue to keep in mind when considering transmission and reflection characteristics of an optical film is the question of whether to take into account the contribution of surface reflections at the outermost front and back major surfaces of the film. Such surface reflections may be relatively minor at normal incidence, e.g., a total of
25 about 10% reflectivity, but can become much greater at highly oblique angles and can differ greatly between s- and p-polarization components. In the case of the present application, the disclosed optical films are preferably, but not necessarily, intended for incorporation into a laminate construction, in which case at least one and possibly both of the outer major surfaces of the film will be in contact with an optical material rather than
30 air. Consequently, unless otherwise noted, the reflection and transmission characteristics reported herein *do not* include the contribution of surface reflections at the outermost front and back major surfaces of the film. Such values are sometimes referred to as “internal

reflection” and “internal transmission” to distinguish them from “external reflection” and “external transmission”, which do include the contributions of the front and back surface reflectivities. However, even if the term “internal” is not used herein, the reflection and transmission characteristics discussed herein should be assumed to be the internal reflection and internal transmission values, unless otherwise noted.

The internal reflection and transmission characteristics can be readily determined whether one is dealing with a computer-modeled optical film or an actual film whose properties are measured in the laboratory. In the case of calculated values of reflectivity and transmission for a modeled film, this is readily accomplished by omitting the calculation of those surface reflectivities from the computed value. The reflection spectrum and all of its features such as the reflectivity at any angle and the band edges for birefringent multilayer films can be calculated using the 4x4 stack code of Berremen and Scheffer, *Phys. Rev. Lett.* **25**, 577 (1970). A description of this method is given in the book “Ellipsometry and Polarized Light” written by Azzam and Bashara, published by Elsevier Science, Holland.

In the case of measured values of reflectivity or transmission, the internal reflection and transmission characteristics can be accomplished by taking measurements of the film in air and subtracting a calculated or measured value representative of only the surface reflectivities. For example, given a multilayer film having a smooth and clear surface layer which is much thicker than the microlayers, the index of refraction of this surface layer can be measured. Once the index of the surface layer is known, the surface reflectivity can be subtracted from the total measured reflectivity by using mathematical formulas which are well known in the art. This procedure works well at both normal incidence (0 degrees) as well as at higher angles such as 60 degrees in air. The reflectivity of the same film at 90 degrees in air or in a higher index medium such as index 1.2 of the examples can be directly measured by optically coupling glass prisms of a known index of refraction to both sides of the film and measuring the reflectivity at the appropriate angle which is easily determined with Snell’s Law. Glass prisms with indices of about 1.5 to 1.7 are suitable for these measurements. The interfacial reflections between such glass prisms and these polymeric films are small at angles near 45 degrees, but they can be easily calculated if necessary for a more accurate measurement of the internal reflectivity of a multilayer optical film.

It is often easier to accurately measure transmission instead of reflection of a film, especially at non-zero angles. Since the absorption of light is relatively small in the films of interest (generally less than 1% for normally incident light), one can simply measure the transmissivity value T and assume that $R = 1 - T$. If the absorption is greater than about a few percent, then it can be measured at normal incidence by separate measurements of R and T . The absorbance at higher angles can then be readily estimated, whereupon reflectivity can be calculated as $R = 1 - A - T$, where R , A , and T are typically expressed as percentages and $1 = 100\%$.

Multilayer optical films disclosed herein exhibit polarizing characteristics for normally incident light and various reflection and transmission characteristics for highly oblique light. The discussion of these characteristics requires reference to parameters referred to variously as a “pass” polarization (and “pass” axis, “pass” plane, etc.), a “block” polarization (and “block” axis, “block” plane, etc.), an s-polarization, and a p-polarization. For purposes of clarity and to help the reader to avoid confusing these terms, we now provide a detailed discussion of these terms.

In reference to traditional polarizing films, light can be considered to be polarized in two orthogonal planes, where the electric vector of the light, which is transverse to the propagation of the light, lies within a particular plane of polarization. In addition, the polarization state of a given light ray can be resolved into two different polarization components: p-polarized and s-polarized light. P-pol light is light that is polarized in the plane of incidence of the light ray and a given surface, where the plane of incidence is a plane containing both the local surface normal vector and the light ray propagation direction or vector.

For example, FIG. 6 illustrates light ray **610** that is incident on a standard polarizer **602** at an angle of incidence θ , thereby forming a plane of incidence **612**. The polarizer **602** includes a pass axis **604** that is parallel to the y-axis, and a block axis **606** that is parallel to the x-axis. The plane of incidence **612** of ray **610** is parallel to the block axis **606**. Ray **610** has a p-polarized component that is in the plane of incidence **612**, and an s-polarized component that is orthogonal to the plane of incidence **612**. The p-pol light of ray **610** has a vector component parallel to the block axis **606** of polarizer **602** and will, therefore, be substantially reflected by the polarizer, while the s-pol light of ray **610** is parallel to the pass axis **604** of polarizer **602** and will, at least in part, be transmitted.

Further, FIG. 6 illustrates ray **620** that is incident on polarizer **602** in a plane of incidence **622** that has a vector component parallel to the pass axis **604** of the polarizer **602**. Therefore, the p-pol light of ray **620** is parallel to the pass axis **604** of the polarizer **602**, while the s-pol light of ray **620** is parallel to the block axis **606** of polarizer **602**. As a result, assuming that the polarizer **602** is an “ideal” polarizer that has a reflectance of 100% at all angles of incident light for light polarized in the block axis and 0% at all angles of incident light for light polarized in the pass axis, the polarizer transmits s-pol light of ray **610** and the p-pol light of ray **620**, while reflecting the p-pol light of ray **610** and the s-pol light of ray **620**. In other words, the polarizer **602** will transmit a combination of p- and s-pol light. The amount of transmission and reflection of p- and s-pol light will depend on the characteristics of the polarizer as is further described herein.

We explain more fully below how the refractive index relationships between adjacent microlayers in the multilayer optical film can be tailored to produce an optical film suitable for use as an optically immersed reflective polarizer, the film also advantageously exhibiting significant increases in reflectivity for obliquely incident light of the “pass” polarization state. The significant reflectivity increases for obliquely incident light may be designed to occur in only one plane of incidence or in two orthogonal planes of incidence, and in either case can be used in recycling systems to help confine or “collimate” light into a narrower viewing cone (as a result of the high reflectivity and low transmission off-axis, in at least one plane of incidence, and in some embodiments in two orthogonal planes of incidence) to provide increased brightness and/or contrast in a display system, or in order to collimate light from a luminaire. The reader should understand that the term “collimate” when used in connection with the disclosed reflective polarizing films is used broadly with the understanding that the films are, in exemplary embodiments, combined with other reflective or diffusive films or elements that at least partially recycle some light that is reflected by the polarizing film. Thus, when the polarizing film has a high transmission for normally incident light and a much lower transmission (higher reflectivity) for highly oblique light, at least some of the oblique light that is reflected may be reflected again by another optical element in the system back towards the polarizing film in a direction that is less oblique, such that it is now more likely to be transmitted by the polarizing film. In this sense, the initially highly

oblique light is “converted” to less oblique light by the time it is transmitted by the polarizing film, and the polarizing film can be said to “collimate” the light impinging on it.

FIGS. 7a-c are provided to illustrate some desirable transmission and reflection properties of an immersed multilayer reflective polarizer as used in the disclosed laminates.

In FIG. 7a, a perspective view of a direction hemisphere is shown. Any point on the hemisphere represents a direction of light propagation, characterized by a polar angle θ and an azimuthal angle ϕ . The z-axis is perpendicular to the plane of the film. For purposes of FIGS. 7a-c, the angles θ , ϕ are assumed to be measured in the optically thick ultra-low index (ULI) material (and thus sometimes referred to as $\theta_{\text{low index}}$ and $\phi_{\text{low index}}$), regardless of where that ULI material layer may be situated relative to the multilayer optical film whose reflection and transmission properties we are concerned with. For example, the ULI layer may be adjacent to the multilayer optical film and disposed between the multilayer optical film and the light source. Alternately, the ULI layer may be adjacent to the multilayer optical film but disposed on the opposite side thereof. Alternately, the ULI layer may be separated from the multilayer optical film in the laminate construction by one or more other films or components, but with no significant air gaps therebetween.

The disclosed multilayer optical films preferably exhibit significant polarizing properties at least for light at low angles of incidence (i.e., normal or near-normal incidence, $\theta \approx 0$). Thus, for normally incident light, the films preferably define a pass axis (e.g. along an in-plane y-axis) of low reflectivity and high transmission over visible wavelengths, and a block axis (e.g. along an in-plane x-axis) of very high reflectivity and very low transmission over visible wavelengths. Preferably, light of the “block” polarization is “blocked”, i.e., characterized by very high reflectivity and very low transmission, over substantially all combinations of θ and ϕ , i.e., over all directions represented by the hemisphere. Thus, with reference to the geometry of FIG. 6, where **606** is the block axis, the disclosed reflective polarizing films preferably maintain high reflectivity for s-polarized light incident in plane **622**, and for p-polarized light incident in plane **612**, for angles θ up to about 90 degrees measured in the ULI material and for substantially all visible wavelengths.

The disclosed polarizing films preferably exhibit a more complicated and interesting behavior for light of the “pass” polarization, as depicted in an idealized, qualitative fashion in FIGS. 7b and 7c, which reproduce the direction hemisphere of FIG. 7a and superimpose thereon transmissive and reflective characteristics of different disclosed films for the “pass” polarization. In each case, the film provides relatively high transmission of light for normal and near-normal incidence. This transmission is said to be “high” in relation to the transmission of the block state light at normal/near-normal incidence, and is usually at least 50% and in some cases much greater than that, even approaching 100%, but in some cases it can also be substantially less than 50% and still be much higher than the transmission of the block state. A film having the latter characteristics may be useful, for example, in a very highly efficient recycling system having minimal losses.

Besides having a “high” transmission for normally incident light of the pass state, the films desirably have a much lower transmission (and higher reflectivity) for light of the pass state that is incident at highly oblique angles θ , at least for some ranges of the azimuthal angle ϕ . The increasing reflectivity with increasing angle effectively compresses the cone of viewing or of propagation of light traversing the film. The transition from “high” to “low” transmission is usually gradual, and thus regions of intermediate reflectivity are shown to separate high and low transmission regions. The “low” transmission at oblique angles is said to be “low” in relation to the transmission of pass state light at normal incidence. By providing reduced transmission, and increased reflectivity, for pass state light traveling at extreme angles of incidence (e.g. supercritical angles of incidence), problems associated with light propagating through the film at angles greater than those for which it was designed, e.g. those associated with the gap depicted in FIG. 4, can be avoided. Particularly in display and lighting applications, the increased reflectivity is preferably maintained relatively uniformly over substantially the entire visible spectrum, to avoid introducing significant color into the system. This in turn introduces certain requirements on the position of the right band edge of the reflection band of the film, due to the characteristic wavelength shift of a multilayer film reflection band with incidence angle.

As will be discussed further below, the multilayer polarizing film can be tailored such that the high and low transmission regions for the pass polarization state light are

relatively insensitive to the azimuthal angle ϕ , as shown in FIG. 7b, or they can be strongly dependent on ϕ as shown in FIG. 7c. For reasons that will be apparent, the azimuth-insensitive characteristics of FIG. 7b can be said to characterize a “2-axis collimating” multilayer reflective polarizing film, whereas the strongly varying azimuthal characteristics of FIG. 7c can be said to characterize a “1-axis collimating” multilayer reflective polarizing film. The distinction between these categories may depend on the application in which the film is intended, and how much of a difference between different azimuthal directions is considered significant in the given application. For convenience in the discussion that follows, we can simply characterize 2-axis collimating polarizing films as exhibiting a similar drop in transmission as a function of polar angle θ for two orthogonal planes of incidence, such as the x-z plane and the y-z plane, while characterizing 1-axis collimating polarizing films as exhibiting a substantial drop in transmission for one plane of incidence and little or no drop in transmission in the orthogonal plane of incidence. Note that in the case of a 1-axis collimating polarizing film, the plane of incidence exhibiting the substantial drop in transmission may be aligned with either the pass axis or the block axis of the film. When the plane of decreased transmission is aligned with the pass axis, the film can be referred to as an p-pol collimating film, because the p-polarization component of pass state light is increasingly reflected with increasing incidence angle, and when the plane is aligned with the block axis the film can be referred to as a s-pol collimating film, because the s-polarization component of pass state light is increasingly reflected with increasing incidence angle.

Depending on system features and requirements, and design constraints, some systems may benefit more by utilizing a 2-axis collimating polarizing film than a 1-axis collimating film, while for other systems the opposite may be true. Further discussion of such design considerations is provided elsewhere herein. Although the present application provides teachings that are pertinent to 1-axis as well as 2-axis collimating polarizing films, further information and examples directed to 1-axis collimating films can be found in U.S. Patent Application Serial No. XX/XXX,XXX, “Immersed Reflective Polarizer With Angular Confinement in Selected Planes of Incidence” (Attorney Docket No. 65900US002), filed on even date herewith and incorporated herein by reference.

Besides providing enough off-axis reflectivity to ensure that light propagating at supercritical angles corresponding to the “gap” of FIG. 4 do not unduly degrade system

performance, a secondary design challenge is the need to reflect and recycle a significant portion of light rays at even lower angles, e.g., from about 45 to 90 degrees in air. In some LCD televisions this angle range is redirected towards the normal with microlens array films. At least some of the reflective polarizers disclosed herein can provide for a
5 substantial reflectivity of this moderate-to-high angle oblique light, in at least one plane of incidence, and can approximate the performance of one to two microlens films.

We have found that the above-described transmission and reflection characteristics can be achieved in practical multilayer films of reasonable design, e.g., having a reasonable number of microlayers and having refractive index relationships that are
10 achievable using existing polymer materials and processing techniques. Some disclosed embodiments, for example, confirm that multilayer reflective polarizers with about 500 layers can be constructed that can reflect up to about 90% of the light in the gap indicated in FIG. 4 while still providing for high transmission values at normal incidence.

The optical properties of a multilayer optical film involve a finite number of
15 parameters that may be considered “primary”, such as the number of microlayers in the film and their distribution into one or more coherent packets within the film, the thicknesses of the various microlayers and the layer thickness profile, and the refractive indices of the layers, for example. In the present application we not only provide examples of how these primary parameters can be selected to produce a multilayer
20 reflective polarizing film suitable for use as an immersed film in a laminate construction, we also identify certain secondary film parameters, and relationships involving such parameters, that may be important in assessing the suitability of a multilayer film in such constructions. These secondary film parameters may include one or more of the following:

25 The internal reflectivity of the film is defined for any of the four polarization cases at a given incidence angle θ , i.e., the reflectivity for p-polarized light incident in the pass plane (“RPpass(θ)”); the reflectivity for s-polarized light incident in the pass plane (“RSblock(θ)”); the reflectivity for p-polarized light incident in the block plane (“RPblock(θ)”); and the reflectivity for s-polarized light incident in the block plane
30 (“RSpass(θ)”), where the pass plane is a plane containing the pass axis and the normal axis of the film, the block plane is a plane containing the block axis and the normal

axis of the film, and the angle θ may be the angle measured in air (θ_{air}) or in the ultra-low index material ($\theta_{\text{low index}}$).

The internal transmission of the film is defined for any of the four polarization cases at a given incidence angle θ , i.e., the transmission for p-polarized light incident in the pass plane (“TPpass(θ)”); the transmission for s-polarized light incident in the pass plane (“TSblock(θ)”); the transmission for p-polarized light incident in the block plane (“TPblock(θ)”); and the transmission for s-polarized light incident in the block plane (“TSpass(θ)”).

We define the average of certain ones of the foregoing parameters. For example
 10 Rpass(θ) is the average of RPpass(θ) and RSpass(θ); and
 Tpass(θ) is the average of TPpass(θ) and TSpass(θ).

We define any of the foregoing parameters under specific conditions. For example:

15 %T00 is the internal transmission of the film at normal incidence for light of the pass polarization, which also equals Tpass(0), TSpass(0), and TPpass(0);

%T block is the internal transmission of the film at normal incidence for light of the block polarization, which also equals Tblock(0), TSblock(0), and TPblock(0);

20 %TA60S is the internal transmission of the film at an incidence angle of 60 degrees measured in air, for s-polarized light incident in the block plane, which also equals TSpass($\theta_{\text{air}}=60$);

25 %TA60P is the internal transmission of the film at an incidence angle of 60 degrees measured in air, for p-polarized light incident in the pass plane, which also equals TPpass($\theta_{\text{air}}=60$);

%TA60 is the average of %TA60S and %TA60P;

%TA90S is the internal transmission of the film at an incidence angle of 90 degrees measured in air, for s-polarized light incident in the block plane, which also equals TSpass($\theta_{\text{air}}=90$);

%TA90P is the internal transmission of the film at an incidence angle of 90 degrees measured in air, for p-polarized light incident in the pass plane, which also equals $TP_{\text{pass}}(\theta_{\text{air}}=90)$;

%TA90 is the average of %TA90S and %TA90P;

5 %TU90S is the internal transmission of the film at an incidence angle of 90 degrees measured in the ultra-low index material, for s-polarized light incident in the block plane, which also equals $TSp_{\text{pass}}(\theta_{\text{low index}}=90)$;

%TU90P is the internal transmission of the film at an incidence angle of 90 degrees measured in the ultra-low index material, for p-polarized light
10 incident in the pass plane, which also equals $TP_{\text{pass}}(\theta_{\text{low index}}=90)$; and

%TU90 is the average of %TU90S and %TU90P.

The position of the long wavelength band edge of the reflection band is sometimes also referred to as the red band edge (RBE) or right band edge, of the reflection band at the specified angle of incidence. In the case of a polarizer that has significant reflectivity of
15 the pass polarization at normal incidence, the reflection band at normal incidence for pass-polarized light differs from the reflection band at normal incidence for block state light. In such cases, unless otherwise noted, the RBE refers to the long wavelength boundary of the reflection band, e.g., the wavelength at which the internal reflectivity drops to 90% of its average value within the band, for block-polarized light.

20 As mentioned above, a reflective polarizer can be made that is also substantially reflective for the pass axis at oblique angles. The pass axis reflectivity at the high angles can be tailored such that it is large for either s-polarized light, p-polarized light, or for both. These two components are incident from orthogonal directions, but both have the electric field vector parallel to a plane containing the pass axis of the film. If a high
25 reflectivity is desired for the p-polarized pass axis light, but not for the s-polarized pass axis light, then a film with a large z-index differential and small y index differential can be used. If a high reflectivity is desired for the s-polarized pass axis light, but not for the p-polarized pass axis light, then a film with a large y-index differential and small z index differential can be used. Note that in order to provide a high reflectivity for light of the
30 block polarization state, the x-index differential should be substantially greater than the y-index differential.

Referring back to FIG. 5, consider the case where the film has been stretched or oriented such that the first material (microlayer **502**) is birefringent and the second material (microlayer **504**) is isotropic having refractive index n_2 , and further that $\Delta n_x > \Delta n_y > 0 > \Delta n_z$, i.e., Δn_z is negative. In this case the first material exhibits both the highest (5) (n_{1x}) and the lowest (n_{1z}) refractive index in the stack, but we shall nevertheless occasionally refer to the first material for convenience as the high index material and the second material as the low index material (not to be confused with the ultra-low index material). In order to exhibit high off-axis reflectivity for pass axis s-pol light, the low index layer should have an index n_2 that is substantially lower than n_{1y} of the high index (10) material. In order to provide high reflectivity for p-pol light, the same low index material should have an index n_2 that is substantially higher than n_{1z} of the high index material. Maximizing one of these values by changing n_2 will minimize the other, so it is clear that in order for both s-pol and p-pol light to be maximally and nearly equally reflected at oblique angles, the y-z index differential of the birefringent layer ($n_{1y} - n_{1z}$) should be (15) maximized. There is a further constraint that n_{1x} be substantially larger than n_{1y} in order that the block axis reflects much more light than the pass axis.

Films that are very reflective for both p-polarized and s-polarized light for the pass axis require large Δy and Δz index differentials. Most multilayer birefringent reflective polarizers are oriented only by a tenter, i.e. oriented only in the x direction. However, this (20) produces a limited range of values for the y index of refraction. The y-index of refraction can be increased by also orienting the film in the y direction. This can be done in a simultaneous biaxial stretching procedure, or with a sequential stretch. Examples of both are given below.

Before providing further explanation, in connection with FIG. 9, about asymmetric film processing considerations and how they affect the microlayer refractive indices, we (25) describe a specific multilayer polarizing film example capable of providing 2-axis collimation.

Optical Film 1.1: 2-axis collimating film, 550 microlayers (modeled)

(30) Oblique angle reflectivity can be enhanced by using a high birefringence, a large number of microlayers, or both. This is an example that uses both approaches. Using the refractive indices listed in the table below, which are representative of suitably uniaxially

oriented 90/10 coPEN for material 1 and coPET for material 2, and further assuming skin layers of the coPET material (isotropic index of 1.555) on both sides of a single stack of 550 microlayers, the microlayers provided with a continuous layer thickness profile optimized for a flat spectrum and providing a left band edge (LBE) at normal incidence at 400 nm and a right band edge (RBE) at normal incidence at 1150 nm, the angular reflectivity of a uniaxial oriented film can be greatly increased.

	nx	ny	nz
Material 1	1.830	1.620	1.505
Material 2	1.555	1.555	1.555
Difference	0.275	0.065	-0.05

The calculated (internal) reflectivity vs. incidence angle curves are plotted in FIG. 8a, where incidence angle is assumed to be in a ULI medium of index 1.2. In the figure, curve **810** represents both $RS_{block}(\theta)$ and $RP_{block}(\theta)$, curve **812** represents $RS_{pass}(\theta)$, and curve **814** represents $RP_{pass}(\theta)$. Note that the pass state reflectivity for both s-polarized and p-polarized light increases to almost 0.9 at the highest angles. For most angles, these reflectivity values will dominate the surface and interfacial reflections in the system construction, even for s-polarized light. FIG. 8b plots the position of the right band edge (RBE) for both the pass polarization and the block polarization as a function of the incidence angle in the index 1.2 ULI material, where curve **820** depicts the RBE position for the block state and s-polarized light, curve **822** depicts the RBE position for the block state and p-polarized light, curve **824** depicts the RBE position for the pass state and s-polarized light, and curve **826** depicts the RBE position for the pass state and p-polarized light.

Choice of polymers and process also affect the cost and manufacturing yield of a film product. For this reason, it may be advantageous to use a different low index material, or to process the polarizer differently. For example, the extrusion equipment needed to make the 550 layer polarizer of Optical Film 1.1 may be somewhat expensive and difficult to design. It may be preferable to laminate or co-extrude two 275 layer films made with the alternative approach described below.

There are several refractive index parameters for the microlayers of a multilayer optical film that affect the reflectivity for any given angle of incidence and we summarize this information in FIG. 9. The reflectivity for s-polarized light increases with the value of $\Delta n_y = n_{1y} - n_{2y}$ which increases to the right along the abscissa. The reflectivity of p-polarized light depends on Δn_y but also depends greatly on $-\Delta n_z = n_{2z} - n_{1z}$ which increases along the vertical axis of FIG. 9. For constrained uniaxially oriented films, the maximum y-z birefringence of the high index layer determines the maximum values Δn_y and Δn_z that can be attained between alternating layers. For coPEN high index layers, this limit is about $\Delta n = 0.12$ because the highest y-index for constrained uniaxially oriented PEN is about $n = 1.62$, and the lowest z-index is about $n = 1.50$. This birefringence is achievable by maximizing the PEN content and orienting the cast web at relatively low temperatures or high draw ratios, or both, as is known in the art of polyester film making.

The values of the refractive index differences Δn_y and Δn_z of some multilayer optical film reflective polarizer products available from 3M Company, namely, Vikuiti™ DBEF-q film and Vikuiti™ APF film, are marked on the plot in FIG. 9 with reference numerals **910**, **912**, respectively. The maximum values of reflectivity for obliquely incident s-polarized and p-polarized light, for uniaxially oriented multi-layers, occur for films that have index differential values along the diagonal dashed line **920** in this plot. Film 1.1, which has equal reflectivity for s-pol and p-pol light, falls on this line at the point $(\Delta n_y = 0.065, \Delta n_z = 0.05)$. At the lower right corner of the graph, the collimating potential for s-polarized light is a maximum because Δn_y is large, but the collimating potential for p-polarized light is zero because Δn_z is zero and the reflectivity of for p-polarized light will not change with angle of incidence. At the upper left corner of the graph, the reflectivity is large for p-polarized light and zero for s-polarized light. Near the point $(\Delta n_y, \Delta n_z) = (0.04, 0.8)$ the reflectivity is a maximum for p-polarized light. When using coPEN films having maximum birefringence in a polarizer construction, changes in the index value of the low index layer moves one along the design space of the dashed line **920**. All index sets to the left of and below the dashed line **920** have lower reflectivity for light at a given angle of incidence. All index sets above and to the right of the dashed line will provide for greater reflectivity at the same angle of incidence. Point **916** represents Optical Film 3.4.

Increasing the index differentials Δn_y and Δn_z , and therefore the reflectivity for oblique light, can be accomplished with the same material sets as discussed above by additionally orienting the films in the machine direction (MD) or y-direction. This process will naturally lower the index in the x-direction, so this places a limit on this approach.

5 However, it allows one to operate in the space above and to the right of the dashed line **920** in FIG. 9. For example, the point **918** represents a reflective polarizing film that can be made by orienting the film in the MD direction and subsequent heat setting. Such film is referred to herein as Optical Film 1.2 and is described further below. Point **914** represents a film made according to the description of Optical Film 1.2, but without
 10 orienting the film in the MD or y-direction.

In general, the foregoing process is referred to as an asymmetrical biaxial orientation. With this process, the y-index of the coPEN can be increased. In the limit of n_y increasing to about 1.75 with a z-index of 1.5, n_x decreases to about 1.75, at which point the film becomes a symmetrical mirror. At some intermediate value of the index
 15 n_{ly} , the film will still be an effective polarizer and the reflectivity for pass axis light will be large, even for low layer counts such as 275 layers. Two or more such films can then be laminated if desired as illustrated by the example below.

Optical Film 1.2: 2-axis collimating film, 275 microlayers (modeled)

20 A multilayer material stack of alternating layers of 90/10 coPEN and PETg can be coextruded and oriented approximately 3:1 in the y-direction and 5:1 in the x-direction to obtain the refractive index characteristics shown in the table below for alternating microlayers, after a high temperature heat set.

	n_x	n_y	n_z
Material 1	1.80	1.675	1.50
Material 2	1.595	1.595	1.595
Difference	0.205	0.08	-0.095

25 If the resulting asymmetrically oriented multilayer optical film is assumed to have a single packet of 275 microlayers, with skin layers of the isotropic PETg on both sides of the packet, the microlayers provided with a continuous layer thickness profile optimized for a

flat spectrum and providing a left band edge (LBE) at normal incidence at 400 nm and a right band edge (RBE) at normal incidence at 1150 nm, a reflective polarizing film is produced whose calculated reflectivity characteristics are shown in FIG. 10. In that figure, curve **1010** represents $RS_{block}(\theta)$, curve **1012** represents $RP_{block}(\theta)$, curve **1014** represents $RP_{pass}(\theta)$, and curve **1016** represents $RS_{pass}(\theta)$. The line **1018** represents the incidence angle in the ULI index 1.2 medium that corresponds to an incidence angle in air of 90 degrees.

Optical Film 1.3: 2-axis collimating film, 275 microlayers x 2 packets

If two of the Optical Films 1.2 are laminated together, to produce an Optical Film 1.3 having a total of 550 layers (but arranged in two coherent packets that are separated from each other by an optically thick layer of the material used in the low index microlayers), the calculated reflectivities shown in FIG. 11 are produced. In that figure, curve **1110** represents $RS_{block}(\theta)$, curve **1112** represents $RP_{block}(\theta)$, curve **1114** represents $RP_{pass}(\theta)$, and curve **1116** represents $RS_{pass}(\theta)$. The line **1118** represents the incidence angle in the ULI index 1.2 medium that corresponds to an incidence angle in air of 90 degrees.

Having described several 2-axis collimating multilayer reflective polarizing films, and before describing additional 1- and 2-axis collimating reflective polarizing films, we now turn our attention to some of the laminate constructions in which the films can be used. Although some emphasis is placed on applications for optical displays, such as backlights and LC panels, the reader should understand that other applications for the disclosed films and laminates are also contemplated. In many cases, the laminate constructions include at least four elements: the disclosed 1- or 2-axis collimating multilayer reflective polarizing film, an optically thick layer of the ULI material, a layer or other mechanism for injecting supercritical light into the multilayer film, and a layer or mechanism for extracting some of the supercritical light out of the system. The latter can be any layer with surface structure or a thick layer with internal scattering and absorbing elements such as an LCD TV panel.

FIG. 12 shows a schematic side view of a laminate construction **1210** that includes an LC panel **1212**. The construction **1210** also includes any of the reflective polarizing

multilayer optical films **1214** as disclosed herein, an optically thick film or layer **1216** of the ULI material, and a diffuser layer **1218**. Light from a backlight, incident on the construction **1210** from below, travels through the various layers to illuminate the display for a viewer.

5 The recycled oblique pass-axis light of the immersed reflective polarizer **1214** increases the on-axis luminous gain of a lighting system while diminishing the oblique angle output of the system. The diffuser layer **1218** can be a heavy diffuser with substantial reflection such as a replacement for e.g. a 50% T, 60% T, or a 70% T diffuser plate, or it can be a microstructured surface such as a prismatic, beaded, or lenslet array.

10 An additional diffuser layer can also be added between the reflective polarizer **1214** and the LCD glass panel **1212**. Such additional diffuser may be desirable, e.g., if the reflective polarizer has some undesirable color. Alternatively, the additional diffuser may be in the form of a microstructure that aids in further collimating the light transmitted by the reflective polarizer. If the diffuser takes the form of a microstructured surface, then the

15 ULI should be placed between the LCD panel **1212** and the microstructured surface. Alternatively for higher efficiency, a second ULI layer can be inserted at that interface while keeping the first ULI layer in the position shown in FIG. 12.

 FIG. 13 is a schematic side view of another laminate construction **1310** that incorporates at least one optically thick ultra low index layer **1316** and a multilayer

20 reflective polarizing film **1314** as disclosed herein, to form an edge-lit or direct-lit backlight or a portion thereof. Layer **1312** is a diffuser layer, which may be semi-specular to aid in hiding color that may be present in the reflective polarizer, or it may be or comprise a structured surface, e.g. linear prismatic surface, that diffuses light and also aids in collimating the light transmitted by the reflective polarizer. Layer **1318** may be or

25 comprise a diffuser plate which is positioned above an array of LEDs or other suitable light sources (not shown) in a direct-lit backlight configuration. Alternatively, layer **1318** may be or comprise a solid light guide, in which case an LED **1320**, or other suitable light source, may inject supercritical angle light into the system via one or more side or end surfaces. This is shown more clearly in the front or top view of FIG. 14, where element

30 **1410** represents the laminate **1310** or layer **1318** thereof, and the regions **1412a-d** illustrate the possible positions at which light sources may be placed for injecting light into the light guide. If the light source(s) are placed at one or both of regions **1412b**, **1412d**, problems

associated with supercritical light propagation may be more acute along axes parallel to the x-axis (note the x-y-z axes in the figures for reference purposes) rather than the y-axis. Similarly, if light source(s) are placed at one or both of regions **1412a**, **1412c**, problems associated with supercritical light propagation may be more acute along axes parallel to the y-axis rather than the x-axis.

FIGS. 15-18 depict a variety of different laminate constructions that comprise a display panel and a disclosed reflective polarizing films.

In FIG. 15, a laminate construction **1510** includes a display panel **1512** such as an LC display panel, an optically thick optical adhesive layer **1514**, a multilayer reflective polarizing film **1516** as disclosed herein, and a diffusing layer **1518** such as a beaded gain diffuser or the like applied to the polarizer film **1516**. In this embodiment, the adhesive layer **1514** may be composed of a conventional adhesive material, which may have a refractive index on the order of 1.5, rather than a ULI material. Thus, the construction **1510** may include no ULI layer therein, as well as no airgaps between the elements shown. Such non-ULI embodiments are discussed further below. The construction **1510** may be combined with a suitable backlight which may be positioned to illuminate the construction **1510** and panel **1512** from below.

In FIG. 16, a laminate construction **1610** is shown that is similar to construction **1510** of FIG. 15, where like elements are given like reference numbers. In the embodiment of FIG. 16, an optically thick ULI layer **1612** is provided between the multilayer reflective polarizing film **1616** and the conventional optical adhesive layer **1514**. Depending on whether the ULI layer **1612** is placed in the laminate (e.g. it may be relocated to lie between the reflective polarizer **1616** and the diffusing layer **1618**), it can serve to limit the propagation of highly oblique light in the reflective polarizer, or to redirect such highly oblique propagating light back towards the reflective polarizer, to a much greater extent than the conventional adhesive material of layer **1514**. As a result, the bandwidth of the reflection band for reflective polarizing film **1616** may be made significantly less than that of polarizing film **1516** in FIG. 15.

In FIG. 17, a laminate construction **1710** is provided with some additional diffusing or collimating elements. In this case, a layer **1709** is provided that comprises a prismatic structured surface film, such as a linear prismatic BEF film. In the layer **1709**, the prisms are disposed on a film substrate, with the prism points in close proximity to or

in contact with the adhesive layer **1514**. The space between the prisms and the adhesive layer is filled by a ULI material. The ULI material of layer **1709** thus planarizes the prisms. Layer **1711** is another conventional optical adhesive layer. Layer **1712** is an optically thick ULI layer. Layer **1716** is a multilayer reflective polarizing film as disclosed herein. Layer **1718** is a diffusing layer, such as a beaded gain diffuser.

In FIG. 18, a laminate construction **1810** includes, besides the other elements already discussed, an optically thick ULI layer **1812**, a multilayer reflective polarizing film **1816** as disclosed herein, and a volume diffuser layer **1818**, arranged as shown.

FIGS. 16-18 are schematic side views of laminate constructions that include a display panel, a multilayer reflective polarizing film, and an optically thick ultra low index layer;

Having described several different laminate-on-display panel constructions, we turn to FIG. 19 for an exemplary laminate-on-light guide construction **1910**. In this embodiment, prism structures **1912**, such as those used in BEF prismatic films, are applied to a multilayer reflective polarizing film **1914** as disclosed herein. In this case, the prisms are exposed to air and transmit light that has passed through the polarizing film **1914** generally upwards towards a display panel or viewer. Such light originates from light sources **1930a**, **1930b**, which are shown in an edge-lit configuration at an edge of a solid light guide **1924**. The light guide **1924** is provided with a pattern of conventional extractors **1926**. Light that escapes from the bottom of light guide **1924** is reflected by a white back reflector **1928**. A pressure sensitive adhesive layer **1922** adheres the light guide **1924** to the other components above, including a graded index ULI layer **1920**, a high haze ULI layer **1918** (which may also be a volume diffuser), and a low haze ULI layer **1916**.

Further Discussion

As mentioned above, several parameters of the reflective polarizer performance may be significant with respect to utility in an LCD backlight, or any other polarized lighting system that requires a reduction in intensity at high angles and/or enhanced intensity on-axis. These parameters include %T block and %T00, discussed above. In the case of 2-axis collimating immersed reflective polarizers, wherein the transmission values for s- and p-polarization components of the pass state may be similar to each other at oblique angles,

the parameters may also include %TA60, %TA90, and %TU90, each of which is an average of s- and p-pol components.

5 These transmission values have a range of preferred values due to requirements of the systems in which they may be applied. In addition, there are trade-offs because changing one of these parameters for a film will change one or more of the other parameters. One reason for this is the limit of birefringence that is available from any material. Polymers such as PEN and PET exhibit a birefringence due to the orientation of the polymer crystallites and some of the molecular chains in a semi-crystalline polymer film. This process of generating crystalline and molecular order is generally referred to as the orientation of the film. The polymer films can be oriented in either the x or y direction, or both. An orientation of the film in any direction will affect the index of reflection in that direction, as well as in the other two directions. The z index of refraction will be minimized if the film is highly oriented in both the x and y directions. The x-index can be increased to a maximum value, but only at the expense of decreasing the y-index to a minimum value. These properties are known, but are restated here in order to discuss the tradeoffs related to optimizing the five parameters listed above. For example, processing the film in order to increase the y index of refraction of the high index layer will decrease %T00, but it will also decrease the x-index of refraction, thus increasing %T block. To a first order approximation, the sum of the x, y, and z indices is a constant. With maximum orientation in either the x or y direction, or both, the z index is minimized for polyester based systems, and likewise for other so-called "positively birefringent systems. Asymmetries in orientation such as a decrease in the x-direction accompanied with an increase in the orientation in the y direction may leave the z index approximately constant.

25 One may wish to minimize the value of %T block for an LCD backlight in order to reduce the loss of light having the block axis polarization via absorption in the absorbing polarizer of the LCD panel. However, since %T block requires a large value of n_x for the high index layer, the y index should not be increased to such a large value that n_x is decreased to the point that Tblock becomes too large. Generally, %T block is desirably less than an average of 15% or 20% over the visible spectrum at normal incidence. Values of %T block of less than 10%, or less than 5% are more desirable.

30 In exemplary embodiments, %T00 is made to be high enough so that substantial amounts of pass axis light are transmitted through to the end use, especially if the

recycling system is not efficient at returning the rejected pass axis rays back to the film. If the system requirements include high reflectivity for s-polarized pass axis light, then a moderate internal reflectivity would be called for at normal incidence. S-polarized light is reflected only if there is a mismatch in the y indices of the alternating microlayers. This mismatch, as well as the number of layers, also determines the value of %T00. Any film that reflects substantial amounts of s-polarized light will also reflect substantial amounts of light at normal incidence. Therefore a film that is intended for a strong reflection of s-polarized light may require an internal reflection at normal incidence of at least 20% and more typically 30% or even 50% or 60%. The more efficient a backlight system is, the lower the acceptable value of %T00 may be. Thus, the internal transmission %T00 can range in value from 40% to as high as 80%.

The value of %TA60 will depend greatly on the value of %T00. As described above, %T00 may need to be substantially less than 100% in order to obtain substantial reflectivity for s-polarized light. If %T00 is reduced, then %TA60 will also be reduced if there are no Brewster angles in the films. A more useful parameter therefore is the ratio of %TA60/%T00. In order to reduce the width of the viewing cone of a display or the angular output of a luminaire from that of a wide angle or Lambertian light source, the ratio %TA60/%T00 should be reduced. For many displays and light sources, the brightness at 60 degrees is desirably much less than the axial or 0 degree brightness. Useful values of %TA60/%T00 for the films described herein range from 0.85 to any lower value.

%TA90 and %TU90 are both desirably minimized in these constructions since this value is representative of how much high angle light is not blocked in the gap region of FIG. 4. The ratios of %TA90/%T00 and %TU90/%T00 are therefore also minimized. The light rays propagating from 56.4 to 90 degrees in a 1.2 index ULI are propagating at angles greater than those that can be injected from air. They are not blocked by TIR at a ULI interface and so they are desirably blocked by reflection from the reflective polarizer for both pass and block polarizations. Note that although neither %TA90 nor %TU90 can be measured in air, they can nevertheless be either estimated by extrapolation from lower angle measurements, or they can be measured directly through an optically coupled prism of known index.

The propagation angle in air of 60 degrees corresponds to 46.2 degrees in a medium of index 1.20, which was the medium for the modeled curves shown in Figures 8a, 10, and 11. The five parameters defined above can be obtained directly from the curves in these Figures. A propagation angle of 90 degrees in a ULI of index 1.2 is equivalent to an angle of 52 degrees in a material of index 1.52. A propagation angle of 90 degrees in air is equivalent to a propagation angle of 41.1 degrees in a material of index 1.52. Thus T90A and T90U can be measured by laminating the film between glass prisms, either of the 45 degrees type and rotating to the appropriate angle, or by using prisms with a special cut angle so that normal incidence can be used on the prism face.

Many film constructions are possible by changing the various indices of refraction, either by the orientation processes for the birefringent layers, or by changing the material composition of the polymeric layers. Also, the number of layers or the optical stack design can be changed. Results for a variety of embodiments, including Optical Films 1.1, 1.2, and 1.3 described above, and Optical Films 2.1, 2.2, and 2.3 described below, are listed in Tables A and B:

Table A

	Film 1.1	Film 1.2	Film 1.3	Film 2.1	Film 2.2	Film 2.3
Layers/Pkt	550	275	275	550	1000	275
Packets	1	1	2	1	1	1
%T00	66	74	59	54	69	36
%TA60S	46	59	41	33	50	14
%TA60P	48	53	36	31	45	36
%TA90S	32	46	30	20	35	5
%TA90P	34	36	22	17	27	36
%TU90S	10	24	14	5	12	0
%TU90P	11	10	5	2	5	36
%T block	0	16	9	1	1	0

Table B

	Film 1.1	Film 1.2	Film 1.3	Film 2.1	Film 2.2	Film 2.3
%T00	66	74	59	54	69	35
%TA60S/%T00	0.70	0.80	0.69	0.61	0.72	0.39
%TA60P/%T00	0.73	0.72	0.61	0.57	0.65	1
%TA90S/%T00	0.48	0.62	0.51	0.37	0.51	0.14

%TA90P/&T00	0.52	0.49	0.37	0.31	0.39	1
%TU90S/%T00	0.15	0.32	0.24	0.09	0.17	0.00
%TU90P/%T00	0.17	0.14	0.08	0.04	0.07	1

The most efficient stack design for creating the highest reflectivity for a broadband reflector with the minimum number of layers is one with a continuous gradation in the quarterwave thickness value from one surface of the stack to the other surface. The Optical Film 1.1 is designed in this manner with 550 continuously graded layers. However, the choice of optical design for a successful product is often restricted by manufacturing costs such as materials and equipment cost. The Optical Film 1.3, whose reflectivity is shown in FIG. 11, is designed to be made by laminating or co-extruding two separately made graded stacks of 275 layers each. The two separate reflectors do not coherently reflect light with respect to one another, and on the average give an increase in reflectivity using the “pile of plates” formula for the incoherent combination of two reflectors:

$$R = \{R1+R2*(1-2*R1)\}/(1-R1*R2).$$

Such a combination of films is more effective at increasing the reflectivity for %T00 than for %TA90 or %TU90 or %T block, as can be observed by comparing FIGS. 10 and 11.

Further Embodiments

Optical Film 2.1: 2-axis collimating film, 550 microlayers (II)

Optical Film 1.1 can be modified by changing the orientation from a centered only film to an asymmetrical biaxially oriented film and by small changes in the material layers. This can be done in a manner that changes the indices of the high index layer from (1.83, 1.62, 1.505) to about (1.80, 1.66, 1.505). Minor changes in the composition of the high index layer may be made to facilitate this process. The low index layer can be changed from 1.555 to 1.58. Note from Tables A and B above that this decreases %T00 somewhat, but it dramatically reduces all of the %T90 values and the ratios %TA60/%T00 and %T90/%T00 .

Optical Film 2.2: 2-axis collimating film, 1000 microlayers

The high index layer of Optical Film 1.1 can be changed from a coPEN to PET, which may have a great materials cost advantage. However, the equipment and processing

cost may be impacted because 1000 continuously graded layers are now required. Indices of $n_x = 1.71$, $n_y = 1.59$ and $n_z = 1.50$ are easily obtained with PET films that are oriented in a constrained uniaxial fashion (standard film tenter), with a low index material with $n = 1.55$. The optical performance is similar to a PEN based film, as noted by the values listed in Tables A and B above.

Optical Film 2.3: 1-axis collimating film, 275 microlayers x 1 packets

A strong s-pol reflecting film can be made with only 275 layers. Using a high index layer with indices of $n_x = 1.82$, $n_y = 1.62$, and $n_z = 1.505$ and a low index layer with an index of 1.505, 275 layers and a constrained uniaxial stretch, the performance values listed in Tables A and B can be obtained. Note that all ratios for T60P/T00 are about equal to 1.0, i.e., the reflectivity for p-polarized light does not increase with angle. The ratios for T60S/T00 are the lowest of any example in Table B. This modeled example is similar to Optical Film 3.4.

Optical Film 3.1: 2-axis collimating film, 275 microlayers x 2 packets (III)

In the process of making Optical Film 3.1, a cast web of a multilayer construction of alternating low and high index polymers was extruded onto a chilled casting wheel for later biaxial orientation on an offline batch film stretching apparatus. The extrusion process conditions necessary to provide the correct layer thickness values of this cast web were explored by the following method to insure that the optical film would have the desired optical properties after orientation on the off line equipment.

Using a feedblock method (see e.g. US 6,783,349 (Neavin et al.)), the cast web for making a reflective polarizer of alternating low and high index polymer layers was made by co-extruding two similar packets of 275 layers of alternating low and high index polymer materials and subsequently joining the two packets of layers. For each 275 layer packet the high index layers were made with a 90/10 coPEN (a copolyester containing 90% ethylene naphthalate repeat units and 10% ethylene terephthalate repeat units). The low index layers were made by blending in the extruder a mixture of 55% by weight of PETg GN071 (available from Eastman Chemicals) with 45% by weight of the 90/10 coPEN. 15% of the low index material was diverted from the melt train to form the protective boundary layers during the coextrusion process (7.5% to each side of the 275

layer extrudate). Skin layers of 100% PETG GN071 were applied to the melt flow, immediately preceding the extrusion die, at a rate of 24% of the total melt flow, 12 % to each side of the film.

This preliminary cast web was then oriented in a standard film making tenter. The
5 cast web was preheated in the tenter for 18 sec at about 157 °C. The film was then stretched along the x-axis at 154 °C at an initial rate of about 60%/second for 4.5 seconds followed by a rate of about 15%/sec for 18 seconds. The total overall stretch ratio in the x direction was about 5.5:1. The film was then heat set for 18 seconds at 227 °C while towing in about 1% of the width.

10 The relative extrusion rates of the low and high index materials in each packet of layers were adjusted so that adjacent material layers in the finished film would each have approximately the same optical thickness. The listed materials, casting speed, and orientation conditions were intended to yield a set of indices of about $n_{1x} = 1.82$, $n_{1y} = 1.62$, $n_{1z} = 1.505$ and $n_2 = 1.595$ and with both the low and high index layers having a
15 quarterwave optical thickness for the block axis that is tuned to reflect from about 425 nm for the thinnest layers and increasing in thickness monotonically in a power law profile to reflect about 1150 nm light for the thickest layers of each packet. The extrusion casting wheel speed was adjusted so that the resultant reflection band spanned this wavelength range. The shape of the power law profile was chosen so that the resultant spectra were
20 relatively flat across most of the spectrum for each packet. The spectral shape was fine tuned using the axial rod technique outlined in US 6,783,349 (Neavin et al.). In the final oriented film, the skin layers were each about 11 microns thick. The total finished film thickness was about 90 microns thick.

The biaxially oriented films should reflect over about the same spectral range as
25 the film just described. However, if it is to be oriented by a factor of 2:1 or 3:1 in the y direction while using the stretch in the x-direction that is described above, then the cast web needs to be made thicker by the same amount of 2:1 or 3:1. For this example the casting wheel was then slowed by a factor of 2.5:1 to thicken the cast web by that ratio compared to the above mentioned preliminary cast web.

30 The 2.5 times thicker cast web was cut into rectangular pieces measuring 127 mm x 254 mm on adjacent sides. These pieces were then stretched on a Karo IV film stretcher, purchased from Brueckner of Siegsdorf, Germany. The cast web was first preheated for

90 seconds at 135 °C and then simultaneously stretched along both the short and the long axes, using a rate of 50%/sec on the short axis. The stretching process starts and stops on both axes simultaneously so the long axis stretch is done at a rate that is 2.5/5.5 times slower than the short axis. The film was then heat set for 30 seconds at 230 °C. The
5 programmed stretch ratios were 5.5 x 2.5 in the 12.7 and 25.4 mm directions respectively to give a finished film sample that was approximately square in shape and 620 mm x 600 mm in dimensions. The machine has only 5 clips for each side of the sample and substantial neck-in of the film occurred at each clip on the long edge of each piece and some neck-in along the short side. This resulted in actual stretch ratios of 4.8 x 2.7. The
10 actual stretch ratios were measured by marking a grid on the cast web with a permanent marker and then measuring the expansion of that grid. Part sizes of 325 mm x 425 mm were obtained for later measurements on LCD TV panels. The film thickness was uniform to about +/- 10% across this sample area. The areas showing the most extreme caliper variations were cut away and smaller parts with about +/- 5% caliper variations were used
15 for later measurements.

Polarized transmission spectra were obtained from one of the thickest parts of the film for both the block and pass axes at normal incidence and at 60 degrees angle of incidence using a diode array spectrophotometer that was fitted with a Glan-Thompson polarizing prism. The block (curve **2012**) and pass (curve **2010**) axis spectra at normal
20 incidence are plotted in FIG. 20a. The red bandedges for the block and pass axis at normal incidence are approximately 1160 nm and 1100 nm. The left bandedge of the block axis can be clearly seen in the figure to be at about 445 nm. This film will transmit some blue light at normal incidence and these parts were rejected in favor of slightly thinner film parts with left bandedges below at least 425 nm for later measurements.

25 Transmission measurements at 60 degrees in air for the s-pol (curve **2022**) and p-pol (curve **2020**) spectra of this film are shown in FIG. 20b. Afterwards, the same piece of film was laminated between 90 degree prisms of BK-7 glass ($n_d = 1.517$ and $n \approx 1.515$ at 633 nm) with an index matching fluid to form a cube with the film along the diagonal. The film was rotationally oriented so that the p-polarized pass axis spectrum could be
30 measured at 45 degrees with an immersion index of 1.517. This spectrum is also plotted in FIG. 20b, as curve **2024**. The angle at 45 degrees to the film in the prisms is greater than 90 degrees from air and equivalent to about 63 degrees in a film of index 1.2.

The red bandedges for the pass axis 60 deg s-pol and p-pol spectra in air are approximately 970 nm and 920 nm respectively, and 790 nm for the p-pol spectrum at 45 degrees in the BK7 glass cube. The average transmission for each spectra from 400 nm to its red band edge (450 to the RBE for the block axis spectrum) are as follows: Block = 12%, pass = 62%, T s-pol 60 = 33%, T p-pol 60 = 37%, T p-pol 45-prism = 12.3%. The reflections from the air interfaces can be subtracted, knowing that the skin layers have an index of 1.564. The formula is: $T_{internal} = 1 - (1 - R - (1 + R) * T) / (1 - R - 2 * R * T)$, where R is the reflectivity at each of the two film surfaces and T is the measured total transmissivity of the film. The calculated values are: Tblock = 12%, T00 = 66%, and T60Air s-pol = 39% and T60Air p-pol = 37% . For the glass prism, the surface reflections are 4.2% at each face, giving a calculated internal transmission of the film equal to 17.5%, or R internal = 82.5%. These properties of Optical Film 3.1 are summarized in the following table:

Table: Optical Film 3.1 Properties

	RBE (nm)	Avg %T in band	Internal %T	T60/Tpass
Block	1160	12	12	
Pass	1100	62	66	
T60 s-pol	970	33	39	0.59
T60 p-pol	920	37	37	0.56
T45 prism	790	12	17.5	

15

Portions of this film that were stretched thinner due to non-uniformities in the batch process exhibited slightly higher reflectivities for all measurements and of course lower red band edges. For example, much of the film exhibited a red band edge of 1100 nm for the block axis, and the average %T was only 10% and values of T60 p-pol as low as 32% were measured. These compare to 12% and 38% of the film described above with the 1060 nm RBE. Improved uniformity in the orientation conditions and therefore the caliper and the reflection values can be achieved by orienting the film in a continuous fashion on a commercial film line.

20

25

Optical Film 3.2: 2-axis collimating film, 275 microlayers x 2 packets (IV)

This film example was made in the same manner as Optical Film 3.1 with the exception that the casting wheel speed was increased by 25%, resulting in a film that is 20% thinner. As a result all of the red band edges were decreased by about 20%. These thinner films also stretched more uniformly on the Karo IV machine than the thicker cast web, resulting in a RBE for the block axis of about 875 nm to 925 nm over most of the film area. These films will begin to transmit red and yellow light rays that are propagating at very high angles in the low index layers. The spectra for this film all have average transmission levels which are similar to those of Optical Film 3.1.

If the reflection band had been compressed by changing the layer thickness profile instead of just shifting it towards the ultra violet, then the transmission values could have been reduced compared to that of Optical Film 3.1.

Optical Film 3.3: 2-axis collimating film, 275 microlayers x 2 packets (V)

In the process of making Optical Film 3.3, a cast web of a multilayer construction of alternating low and high index polymers was extruded onto a chilled casting wheel for in-line biaxial orientation on a sequential film orientation line. Using a feedback method (see e.g. US Patent 6,783,349 (Neavin et al.)), a reflective polarizer of alternating low and high index polymer layers was made by co-extruding a cast web of 275 layers of alternating low and high index polymer materials and subsequently orienting the cast web, first in a length orienter (LO), then in a tenter. The high index layers were made with a 90/10 coPEN (a copolyester containing 90% ethylene naphthalate repeat units and 10% ethylene terephthalate repeat units). The low index layers were made by blending in the extruder a mixture of 55% by weight of PETg GN071 (available from Eastman Chemicals) with 45% by weight of the 90/10 coPEN. 15% of the low index material was diverted from the melt train to form the protective boundary layers during the coextrusion process (7.5% to each side of the 275 layer extrudate). Skin layers of 90/10 coPEN were applied to the melt flow, immediately preceding the extrusion die, at a rate of 20% of the total melt flow, 10 % to each side of the film. The target refractive indices for the high index layers of the film were $n_x = 1.79$, $n_y = 1.675$, $n_z = 1.505$. Development of these indices requires an asymmetric orientation of the film.

For the length orientation, the LO preheat rollers were heated to 102 °C. The final heating just before the stretch gap was applied using a quartz lamp. The actual stretch

temperatures are not measurable except in terms of the index of refraction in the coPEN achieved by the process. The IR lamp was adjusted while simultaneously adjusting the tenter conditions until the indices of $n_x = 1.793$, $n_y = 1.671$, $n_z = 1.502$ were measured on the skin layers. The LO overall stretch ratio was 2.7:1 and the overall tenter stretch ratio was 4.5:1.

The LO'd film was preheated in the tenter for about 13 sec at about 140 °C. The film was then stretched at 132 °C at an initial rate of about 50%/sec. The film was then heat set for 13 seconds at 232 °C while towing in about 2% of the width.

The relative extrusion rates of the low and high index materials in each packet of layers were adjusted so that adjacent material layers in the finished film would each have approximately the same optical thickness. The extrusion rates for both the low and high index material were adjusted so that both sets of layers each had about a quarterwave optical thickness for the block axis that is tuned to reflect from about 425 nm for the thinnest layers and increasing in thickness monotonically in a power law profile to reflect about 1200 nm light for the thickest layers of the film. The extrusion casting wheel speed was adjusted so that the resultant reflection band spanned this wavelength range. The shape of the power law profile was chosen so that the resultant spectra were relatively flat across most of the spectrum for each packet. The spectral shape was fine tuned using the axial rod technique outlined in US 6,783,349 (Neavin et al.). In the final oriented film, the skin layers were each about 6 microns thick. The total finished film thickness was about 45 microns thick. Two of the resultant films made by this method were then laminated using a clear optical adhesive. The pass axes of the two films in the laminate were parallel. The transmission spectra were measured using the diode array spectrophotometer at normal and 60 degrees. The red band edges and the % transmission values were determined from those spectra and are listed in the table below. The ratio of $T(\theta = 60_{\text{air p-pol}})/T_{\text{pass}}(0)$ is lower than for Optical Film 3.1.

Table: Optical Film 3.3 Properties

	RBE (nm)	Avg %T in band	Internal %T	T60/Tpass
Block	1200	12.2	12.3	
Pass	1150	56.5	60.1	
T60 s-pol	970	29.7	34.3	0.57

T60 p-pol	950	31.7	31.9	0.53
-----------	-----	------	------	------

Optical Film 3.4: 1-axis collimating film (s-pol), 275 microlayers

Cast web of a multilayer construction of alternating low and high index polymers was extruded onto a chilled casting wheel for in-line tenter orientation on a film line.

5 Using a feedblock method (see e.g. US 6,783,349 (Neavin et al.)), a reflective polarizer of alternating low and high index polymer layers was made by co-extruding a cast web of 275 layers of alternating low and high index polymer materials and subsequently orienting the cast web, first in a length orienter (LO), then in a tenter. The high index layers were made with a 90/10 coPEN (10%PET). The low index layers were made with Ecdel
 10 polymer FN007 (available from Eastman Chemicals). 15% of the high index material was diverted from the melt train to form the protective boundary layers during the coextrusion process (7.5% to each side of the 275 layer extrudate). Skin layers of PETg 14285 (available from Eastman Chemicals) were applied to the melt flow, immediately preceding the extrusion die, at a rate to provide finished skin layers of about 8 microns thickness on
 15 each side of the film. The target indices for the high index layers of the film were $n_x = 1.82$, $n_y = 1.62$, $n_z = 1.51$. The Ecdel has an index of about 1.505 and the PETg has an index of about 1.564 at 633 nm.

The relative extrusion rates of the low and high index materials in each packet of layers were adjusted so that adjacent material layers in the finished film would each have
 20 approximately the same optical thickness. The extrusion rates for both the low and high index material were adjusted so that both sets of layers each had about a quarterwave optical thickness for the block axis that is tuned to reflect from about 400 nm for the thinnest layers and increasing in thickness monotonically in a power law profile to reflect about 950 nm light for the thickest layers of the film. The extrusion casting wheel speed
 25 was adjusted so that the resultant reflection band spanned this wavelength range. The shape of the power law profile was chosen so that the resultant spectra were relatively flat across most of the spectrum. The spectral shape was fine tuned using the axial rod technique outlined in US 6,783,349 (Neavin et al.). In the final oriented film, the skin layers were each about 6 microns thick. The total finished film thickness was about 45
 30 microns thick.

The cast web was oriented in a standard film making tenter. The cast web was preheated in the tenter for 20 sec at about 144 °C. The film was then stretched at 144 °C at an initial rate of about 50%/second. The total overall stretch ratio in the x direction was about 5.5:1. The film was then heat set for about 20 seconds at 227 °C while towing in about 1% of the width.

The block (curve **2116**), pass (curve **2112**), s-pol 60 (curve **2114**), and p-pol 60 (curve **2110**) spectra for the resulting film are plotted in FIG. 21. The long wavelength bandedges (red bandedges or RBE) and the average transmission within each plotted reflection band, are listed in the table below. The ratio of T s-pol ($\theta = 60$ degAir) /Tpass(0) for this Optical Film 3.4 is 0.29.

Table: Optical Film 3.4 Properties

	RBE (nm)	Avg %T in band	Internal %T	T60/Tpass
Block	970	1.4	1.4	
Tpass(0)	870	37.6	39.1	
T60 s-pol	725	10.8	11.3	0.29
T60 p-pol	700	39.4	39.8	1.02

Construction 1.1: Laminated LCD panel/air-guide

The Optical Films 3.1 through 3.4 were each laminated to a Samsung LCD TV panel. The panel was from Samsung commercial TV set (model#: LN32B360C5D), with the diagonal size of 32". In the experiments, only a portion of the 32" panel was illuminated by a 200 mm x 400 mm backlight behind the panel.

A schematic side-view of this backlight **2210** is shown in FIG. 22. In the figure, dimensions (in units of millimeters) are provided in parentheses. A light engine with white LEDs and parabolic-like reflectors, see item **2234**, are attached to the left of the hollow cavity. The inside of the light engine and the cavity are lined with ESR (available from 3M Company) if not otherwise specified. The hollow cavity **2232** is 17mm deep, 200 mm wide and 400 mm long. 20 cool white Rebel LEDs (available from Philips Lumileds Lighting Company, San Jose, California, USA) were arranged on a linear array along the left edge (the 200 mm edge) with the pitch of 9.8mm on metal core printed circuit boards (MCPCB), which were then attached to extruded aluminum heat sinks for thermal management.

The luminance of the backlight center as a function of viewing angle, axial luminance (in units of nits), the half-luminance angle, and contrast ratio were measured using an Autronic Conoscope Conostage 3 (available from Autronic-Melchers GmbH, Karlsruhe, Germany).

5 In all experimental examples, the reflective polarizers were arranged such that their block axis was parallel to the 400 mm edge of the backlight. The films were laminated to the TV panel according to the schematic diagram in FIG. 22. In the figure, item **2212** is the LC panel, **2214** is an optical adhesive, **2216** is the multilayer optical film being tested, **2218** is an optical adhesive, **2220** is a layer of PET, **2222** is a layer of ULI material, **2224**
10 is an optical adhesive, **2226** is a polycarbonate film, and **2228** is bead coating, similar to a beaded gain diffuser film.

As a control sample to compare the TV performance using a non-immersed film system, the TV brightness and contrast was first measured on this Samsung TV panel using this backlight but with an air gap between the panel and the film stack. For rigidity,
15 the film stack was laminated to a clear polycarbonate sheet in the position where the panel **2212** is depicted in FIG. 22. The TV panel was then positioned approximately 1 mm above the clear polycarbonate sheet. The brightness and contrast of the TV were obtained by the Autronics instrument for all polar angles out to 80 degrees at all azimuthal angles from 0 to 360 degrees. This data can be summarized by plotting the brightness and
20 contrast for light exiting the TV along the two major axis of the polarizing film – the block and pass axis. The pass axis of the reflecting polarizer is of course aligned with pass axis on the adjacent absorbing polarizer of the TV panel.

Substantially only pass axis p-polarized light enters the TV in the plane of incidence of the pass and normal axes, so this data is plotted as brightness and contrast for
25 p-polarized light. Similarly, only pass axis s-polarized light enters the TV in the plane of incidence of the block and normal axes, so this data will be plotted as brightness and contrast for s-polarized light. As indicated by the data presented below, the TV brightness and contrast is greatly affected by the transmission characteristics of the reflective polarizer for s and p-polarized light as a function of angle and value of the polarizer
30 bandwidth. The bandwidth is represented by the value listed for the long wavelength band edge, or red bandedge (RBE).

The reflective polarizing film used for the control sample was the Optical Film 3.4, which is referred to as an s-pol collimating film. The brightness and contrast of the TV for the two major axes, representative of s-polarized (curves **2310**, **2316**) and p-polarized (curves **2312**, **2318**) light are plotted in FIGS. 23a and 23b, respectively. The brightness units are only relative, and will be used for comparing the various samples described here. A half luminance viewing angle can be defined as the polar angle at which the brightness drops to half of the brightness value that is measured on-axis (0 degrees). This viewing angle is typically different for the block and pass axes.

The contrast data is a ratio of the TV brightness in the “on”, or “white” state divided by the panel brightness in the “off” or “dark” state. It is known that high angle light that enters the TV panel can degrade the contrast of the TV panel due to the scattering of this light by the various pixel elements within the LCD panel. The light scattering is typically lowest for light entering at normal incidence. For this reason, it is desirable to limit the amount of light entering the LCD panel at high angles. When the air gap is eliminated between the diffuser and the TV panel, light can be injected into the panel at angles greater than can enter from air, thus seriously degrading the panel contrast. The films described here, in combination with the ultra low index film layer, are designed to reduce the amount of light entering the panel at these extreme angles.

When the Optical Film 3.4, which was designed for use in air, is immersed by laminating the film stack to the TV panel as shown in FIG. 22, both the brightness and contrast are substantially reduced. This is evident from the measurements which are plotted in FIGS. 23c (brightness) and 23d (contrast). In these figures, curve **2320** represents s-pol with ULI, curve **2322** represents p-pol with ULI, curve **2324** represents p-pol without ULI, curve **2326** represents s-pol without ULI, curve **2330** represents p-pol with ULI, curve **2332** represents s-pol with ULI, curve **2334** represents p-pol without ULI, and curve **2336** represents s-pol without ULI. Note also the additional substantial reduction in brightness and contrast when the film is applied without the low index layer. However, the low index layer cannot block all of the high angle light by the TIR mechanism. Light propagating in an index 1.2 layer at angles from 56.4 degrees to 90 could not enter from air, but are not TIR'd by the low index layer. The light in this angle range, i.e. the “gap” range referred to earlier, can be substantially reflected by the

reflective polarizer if it is designed to have high reflectivity for pass axis light at these angles.

The Optical Film 3.3 has the widest bandwidth of the four films 3.1-3.4, and also the highest average of s-pol and p-pol reflectivity at high angles. When Optical Film 3.3 is laminated to the LCD panel in the same manner as above, the TV brightness and contrast are only slightly reduced from the construction with an air gap. This is evident from the data plotted in FIGS. 23e (brightness) and 23f (contrast). In these figures, curve **2340** represents p-pol with ULI, curve **2342** represents s-pol with ULI, curve **2344** represents p-pol without ULI, curve **2346** represents s-pol without ULI, curve **2350** represents p-pol with ULI, curve **2352** represents s-pol with ULI, curve **2354** represents s-pol without ULI, and curve **2356** represents p-pol without ULI.

The asymmetry in the brightness data for negative vs. positive angles is thought to be due to the nature of the backlight used for these measurements. All of the LEDs are placed along one edge and directed so as to inject light at high angles. The bead coating on the bottom of the film is intended to randomize the directionality of this light, but is not quite sufficient. However, note that the contrast is essentially independent of direction. The asymmetry is quite pronounced for the examples laminated without the low index layer, thus showing the great advantage of combining the low index layer with these films.

The Optical Film 3.1 has a slightly lower RBE than Optical Film 3.3. The average bandedge of Optical Film 3.1 was only about 1130 nm compared to 1200 nm for Optical Film 3.3. When the Optical Film 3.1 is laminated to the LCD panel, the contrast is slightly lower compared to Optical Film 3.3. However, the brightness is improved. This may be due to the lower block state transmission of Film 3.1 compared to Film 3.3. As was noted above, the average RBE and Tblock were both lower for most of the film area than the numbers reported simply from the one set of spectrum taken at a single point on the film. The lower value of Tblock is important for brightness, especially for cases where Tpass is also low. The large degree of light recycling with these systems can magnify the losses many times compared to a one-pass transmission measurement. The contrast and brightness results are shown in FIGS. 23g (brightness) and 23h (contrast). In these figures, curve **2360** represents p-pol with ULI, curve **2362** represents s-pol with ULI, curve **2364** represents p-pol without ULI, curve **2366** represents s-pol without ULI, curve

2370 represents s-pol with ULI, curve **2372** represents p-pol with ULI, curve **2374** represents s-pol without ULI, and curve **2376** represents p-pol without ULI.

Optical Film 3.2 is made with the same process and materials as Optical Film 3.1, but with an intentionally shifted reflection band. The RBE is shifted towards the blue, making it less effective at reflecting light which is incident at high angles. As a result, both the brightness and contrast of the TV panel is reduced when Optical Film 3.1 is replaced with Optical Film 3.2 on the TV panel, most notably when the low index layer is omitted. These data are plotted in FIGS. 23i (brightness) and 23j (contrast). In these figures, curve **2380** represents p-pol with ULI, curve **2382** represents s-pol with ULI, curve **2384** represents p-pol without ULI, curve **2386** represents s-pol without ULI, curve **2390** represents s-pol with ULI, curve **2392** represents p-pol with ULI, curve **2394** represents s-pol without ULI, and curve **2396** represents p-pol without ULI.

Several of the film parameters for each of Films 3.1-3.4 are listed in Table C below along with the corresponding brightness and contrast for each configuration. The T60s/T(0) and T60p/ T(0) values refer to measurement in air at 60 and 0 degrees, and are corrected to report the internal transmission values. These values are taken from the tables associated with each example. The results are listed in order according to the measured TV contrast.

Table C

	Control/air	Film 3.3	Film 3.1	Film 3.2	Film 3.4
RBE	970	1200	1130	900	970
T60s/T(0)		0.57	0.59	0.59	0.29
T60p/T(0)		0.53	0.56	0.56	1.02
Avg T60/T(0)		0.55	0.575	0.575	0.655
Brightness with ULI	94	86	92	85	71
Brightness without ULI		68	56	32	31
Contrast with ULI	2710	2600	2360	2075	1600
Contrast without ULI		1520	1100	516	431

20

The fact that Optical Film 3.2, with a RBE of only 900 nm provides for both higher brightness and contrast than Optical Film 3.3 which has a RBE of 970 nm indicates that both RBE and the reflectivity at high angles are important parameters.

To better understand the combined effect of RBE value and the T60/T(0) ratio, the contrast values (curve 2410), the product of RBE*T(0)/T60 (curve 2412), and the relative brightness*T(0)/T60 (curve 2414) are all plotted vs. film sample (A representing Optical Film 3.1, B representing Optical Film 3.2, C representing Optical Film 3.3, and D representing Optical Film 3.4) in FIG. 24 in the order of increasing contrast. The brightness is scaled by a factor of 10 simply for convenience in plotting the information. The nearly parallel trends of these parameters indicate that both increased RBE and higher reflectivity for high angle light are important for maintaining a high contrast and brightness in the LCD panel.

Discussion:

Laminates with Immersed Reflective Polarizing Film and no Ultra-Low Index Layer

The shift in the reflection band to lower wavelengths with increasing angle of propagation becomes quite large when the film is immersed in higher index media. For example, in U.S. Patent Application Publication US 2008/0037127 (Weber), "Wide Angle Mirror System", it is noted that when the z-index of all layers of the mirror are close to the index of the immersing medium, the RBE will shift to about zero nm at high angles for p-polarized light, no matter what the bandedge at normal incidence. This potentially infinite bandshift thus requires the use of a TIR layer of a very low index to block high angle rays of light. The s-pol reflecting Optical Film 3.4 is an example with the z-index of both layers having an index of 1.505. If this film were immersed between a standard diffuser and TV panel, using a standard adhesive with $n \approx 1.49$, then the dramatic movement of the reflection band would allow large amounts of light to transmit at high angles. However, if only the low index layer were changed to one with an index of e.g. 1.58, then the shift in the RBE with angle of incidence is greatly reduced. The high index layer need not be changed, indeed, it requires a much lower z-index than the low index layer if the film is to perform as a wide angle polarizer and if p-polarized light is to be reflected at high angles.

Thus we have discovered that reflective polarizers which are designed to reflect most block axis light and p-polarized pass axis light at high angles do not exhibit

prohibitively large bandshifts with changes in the angle of incidence. The bandshift is finite for the film and immersion indices discussed here and indeed one that can be compensated for by the addition of a reasonable number of layers that extend the bandwidth of the polarizer to a degree that an ultra low index layer is not needed to reflect the light at the highest angles. On the other hand, multilayer birefringent reflective polarizers that are designed to transmit p-polarized pass axis light and substantially reflect s-polarized pass axis light will generally require an ultra low index layer to perform when immersed in a high index medium.

Example NU-1: immersed film with no ultra low index layer

If the index set of the reflective polarizer is ($n_x = 1.80$, $n_y = 1.67$, $n_z = 1.505$) for the “high” index layers and $n = 1.585$ for the “low” index layers, the right band edge for p-pol light does not drop below about 600 nm if the film is immersed in an index of 1.49. These film indices can be obtained with an asymmetrical biaxial orientation and heat setting of a PEN or a coPEN film having a very high PEN content, e.g. 95% PEN or greater. A ratio of orientation for the block axis to the pass axis direction can be about 2:1, although one can easily vary this ratio to optimize the n_x vs. n_y index. The low index material can be made using a blend of, e.g., PETg and a coPEN. All s-polarized visible light is reflected and p-polarized light below 650 nm is reflected at angles up to about 77 degrees.

Using the suggested indices and materials listed above for this example, a continuously graded stack of 550 alternating layers of the low and high index materials can be designed to give a high reflectivity polarizer for wavelengths from 400 nm to at least 1800 nm. Alternatively, two films that are designed to reflect from e.g. 400 to 900 nm and from 850 to 1800 nm can be laminated or co-extruded to form an ultra wide reflective polarizer that can be immersed in normal adhesive bonded films. The lowest indices in typical LCD panel and backlight components are generally in an adhesive layer. Many adhesives have indices close to 1.48 or 1.49. Some may be lower, such as silicone based adhesives. Diffuser plates, light guides and diffuser coatings and other media in which this film may be immersed have indices of 1.49 or higher. The lowest index layer in the immersion stack determines the effective immersion constant. For this reason, at least one layer in the film laminate should have an index of 1.49 or lower.

1800 nm can be chosen as the red bandedge for the pass axis at normal incidence because such a bandwidth of 400 nm to 1800 nm is achievable with a practical number of layers, such as about 500 layers for PEN based polymer films and about 1000 to 2000 layers for PET based films. Most lighting and display backlights utilize visible light with wavelengths mostly less than 650 nm. Although some red light will leak through at the highest angles, the percentage of light incident above 80 degrees is generally small. Bandedges of 1600 to 2000 nm will work well for a wide range of applications.

Example NU-2: PETg/coPEN 90-10 ultra wide band polarizer

In order to demonstrate that an optical film can be made with the ultra wide bandwidths described in Example NU-1, and with an acceptable level of uniformity of transmission vs. wavelength over such a wide band, the following two films were made and then laminated with an optical adhesive. The first film reflects from about 400 nm to 900 nm and the second film reflects from about 800 nm to 1800 nm. The bandedges were designed to be gradual in order that the transitional overlap in the spectra from one film to the other in the laminate is relatively smooth. Both films were made using a feedback method such as that described in US Patent 6,783,349 (Neavin et al.) with 275 alternating layers of a 90/10 coPEN (90% PEN/10% PET) and PETg (available from Eastman Chemicals, Tennessee). The first film was optimized for uniformity of transmission and bandedge slopes, with bandedges of about 400 and 900 nm. The extrusion casting wheel was then slowed down by a factor of 2 so that the 400 nm bandedge was moved out to 800 nm and the 900 nm bandedge moved out to 1800 nm.

The wavelength range of overlap of the two films, between about 800 to 900 nm for the pass axis, exhibited some spectral ringing due to interference effects between the two films, but the spectrum acceptably smooth. This ringing and the other spectral non-uniformities evident in the spectrum will cause the transmitted light to be slightly colored. This color can be masked by the use of a moderate diffuser on the exit side of the film. This diffuser could be part of a prism array or other surface structure for further collimating the transmitted light.

The laminated film requires some overlap of the reflection bands of the two separate films and is therefore not quite as efficient as a single film made from one continuously graded stack of 550 layers. However this approach is simpler from a process

standpoint since it is difficult and expensive to make a feedblock that can generate 550 alternating $\frac{1}{4}$ wave thick layers with a continuous gradient and no intervening thick layers. The least effective optical design is a stack of two or more films that are partially reflective over the entire wavelength range. The non-coherent interference effects
5 between separate reflectors will increase the pass axis reflectivity and decrease the block axis reflectivity compared to the coherent stacks described above.

The high angle reflection of this polarizer for s and p-polarized light will not be quite as good as for Example NU-1 above. The index set for this film (at 633 nm) was: high index layer ($n_x = 1.82$, $n_y = 1.62$, $n_z = 1.51$), low index layer is PETg with $n = 1.564$.
10 However, note that Δn_y and Δn_z are both greater than 0.05. The pass axis had an external transmission of about 75% from 400 nm to 1000 nm and about 80% from 1000 nm to 1800 nm at normal incidence. The block axis showed a transmission of about 5% for light from 400 nm to 1000 nm and about 8% for light from 1000 nm to 1800 nm at normal incidence. Both of these transmission measurements were made with polarized light
15 which was arranged to be parallel to the axis being measured, as was the case for all the examples.

Item 1 is a film construction, comprising a plurality of microlayers configured to selectively transmit and reflect light as a function of angle and polarization over an extended wavelength region including visible wavelengths, the microlayers defining a pass
20 axis for normally incident visible light of a first polarization and a block axis for normally incident visible light of a second polarization, the microlayers also characterized by increased reflectivity at oblique angles so as to transmit visible light of the first polarization in a compressed viewing cone; and an optically thick low index layer having an ultra low refractive index coupled to the microlayers in such a way as to limit
25 propagation of highly oblique light in the microlayers, or to redirect such highly oblique propagating light back towards the microlayers.

Item 2 is the construction of item 1, wherein the ultra low refractive index, averaged over visible wavelengths, is at least 1.1 but no more than 1.3.

Item 3 is the construction of item 2, wherein the ultra low refractive index,
30 averaged over visible wavelengths, is at least 1.15 but no more than 1.25.

Item 4 is the construction of item 1, wherein the plurality of microlayers has a pass axis, a block axis, and a normal axis, and wherein the plurality of microlayers has an

average internal reflectivity over visible wavelengths, as a function of propagation angle θ ,
of: $RP_{\text{pass}}(\theta)$ for p-polarized light incident in a pass plane containing the pass axis and
the normal axis; $RS_{\text{block}}(\theta)$ for s-polarized light incident in the pass plane; $RP_{\text{block}}(\theta)$
for p-polarized light incident in a block plane containing the block axis and the normal
5 axis; and $RS_{\text{pass}}(\theta)$ for s-polarized light incident in the block plane; wherein $R_{\text{block}}(\theta)$ is
an average of $RS_{\text{block}}(\theta)$ and $RP_{\text{block}}(\theta)$, and $R_{\text{pass}}(\theta)$ is an average of $RS_{\text{pass}}(\theta)$ and
 $RP_{\text{pass}}(\theta)$; wherein the plurality of microlayers has an average internal transmission over
visible wavelengths, as a function of the propagation angle θ , of: $TP_{\text{pass}}(\theta)$ for p-
polarized light incident in the pass plane; $TS_{\text{block}}(\theta)$ for s-polarized light incident in the
10 pass plane; $TP_{\text{block}}(\theta)$ for p-polarized light incident in the block plane; and $TS_{\text{pass}}(\theta)$ for
s-polarized light incident in the block plane; and wherein $T_{\text{block}}(\theta)$ is an average of
 $TS_{\text{block}}(\theta)$ and $TP_{\text{block}}(\theta)$, and $T_{\text{pass}}(\theta)$ is an average of $TS_{\text{pass}}(\theta)$ and $TP_{\text{pass}}(\theta)$.

Item 5 is the construction of item 4, wherein $T_{\text{block}}(0)$ is less than 20%, and
wherein $T_{\text{pass}}(0)$ is in a range from 40% to 80%.

15 Item 6 is the construction of item 5, wherein $T_{\text{block}}(0)$ is less than 10%, and
wherein $T_{\text{pass}}(0)$ is in a range from 55% to 75%.

Item 7 is the construction of item 5, wherein the propagation angle θ is an angle
 θ_{air} measured in air, and wherein $T_{\text{pass}}(\theta_{\text{air}} = 60^\circ) < 0.85 * T_{\text{pass}}(0)$.

Item 8 is the construction of item 7, wherein $T_{\text{pass}}(\theta_{\text{air}} = 60^\circ) < 0.75 * T_{\text{pass}}(0)$.

20 Item 9 is the construction of item 5, wherein the propagation angle θ is an angle
 $\theta_{\text{low index}}$ measured in the optically thick low index layer, and wherein $T_{\text{pass}}(\theta_{\text{low index}} =$
 $90^\circ) < 0.6 * T_{\text{pass}}(0)$.

Item 10 is the construction of item 9, wherein $T_{\text{pass}}(\theta_{\text{low index}} = 90^\circ) < 0.3 *$
 $T_{\text{pass}}(0)$.

25 Item 11 is the construction of item 1, wherein the plurality of microlayers contain
less than 1000 microlayers.

Item 12 is the construction of item 1, further comprising: a first and second
optically thick layer arranged such that the optically thick low index layer and the plurality
of microlayers are both disposed between the first and second optically thick layers;
30 wherein the first and second optically thick layers have higher refractive indices than that
of the optically thick low index layer.

Item 13 is the construction of item 12, wherein the first optically thick layer comprises a light guide.

Item 14 is the construction of item 12, wherein the first optically thick layer comprises a diffusing layer.

5 Item 15 is the construction of item 12, wherein the first optically thick layer comprises a display panel.

Item 16 is a film construction, comprising a multilayer optical film configured to operate substantially as a reflective polarizer for visible light at normal incidence and to operate substantially as a mirror for visible light at oblique angles; and an optically thick
10 low index layer having an ultra low refractive index attached to the multilayer optical film.

Item 17 is the construction of item 16, wherein the ultra low refractive index, averaged over visible wavelengths, is at least 1.1 but no more than 1.3.

Item 18 is the construction of item 17, wherein the ultra low refractive index, averaged over visible wavelengths, is at least 1.15 but no more than 1.25.

15 Item 19 is the construction of item 16, wherein the multilayer optical film has a pass axis, a block axis, and a normal axis, and wherein the multilayer optical film has an average internal reflectivity over visible wavelengths, as a function of propagation angle θ , of: $R_{Ppass}(\theta)$ for p-polarized light incident in a pass plane containing the pass axis and the normal axis; $R_{Spass}(\theta)$ for s-polarized light incident in the pass plane; $R_{Pblock}(\theta)$ for
20 p-polarized light incident in a block plane containing the block axis and the normal axis; and $R_{Sblock}(\theta)$ for s-polarized light incident in the block plane; wherein $R_{block}(\theta)$ is an average of $R_{Sblock}(\theta)$ and $R_{Pblock}(\theta)$, and $R_{pass}(\theta)$ is an average of $R_{Spass}(\theta)$ and $R_{Ppass}(\theta)$; wherein the multilayer optical film has an average internal transmission over visible wavelengths, as a function of the propagation angle θ , of: $T_{Ppass}(\theta)$ for p-
25 polarized light incident in the pass plane; $T_{Spass}(\theta)$ for s-polarized light incident in the pass plane; $T_{Pblock}(\theta)$ for p-polarized light incident in the block plane; and $T_{Sblock}(\theta)$ for s-polarized light incident in the block plane; and wherein $T_{block}(\theta)$ is an average of $T_{Sblock}(\theta)$ and $T_{Pblock}(\theta)$, and $T_{pass}(\theta)$ is an average of $T_{Spass}(\theta)$ and $T_{Ppass}(\theta)$.

30 Item 20 is the construction of item 19, wherein $T_{block}(0)$ is less than 20%, and wherein $T_{pass}(0)$ is in a range from 40% to 80%.

Item 21 is a film construction, comprising a multilayer optical film configured to operate substantially as a reflective polarizer for visible light at normal incidence and to operate substantially as a mirror for visible light at oblique angles; and wherein the value of $RBE \cdot T_{pass}(0) / T_{pass}(60) > 1500$.

5 Item 22 is a film construction, comprising a multilayer optical film configured to operate substantially as a reflective polarizer for visible light at normal incidence and to operate substantially as a mirror for visible light at oblique angles, the multilayer optical film being characterized by layer-to-layer refractive index differences Δn_x , Δn_y , and Δn_z , and wherein $\Delta n_x \geq 0.10$, $\Delta n_y \geq 0.05$, and $\Delta n_z \leq -.05$.

10 Item 23 is the construction of item 22, further wherein the film exhibits a reflection band having a red band edge (RBE), the RBE being disposed at a wavelength of at least 1000 nm.

15 Unless otherwise indicated, all numbers expressing quantities, measurement of properties, and so forth used in the specification and claims are to be understood as being modified by the term “about”. Accordingly, unless indicated to the contrary, the numerical parameters set forth in the specification and claims are approximations that can vary depending on the desired properties sought to be obtained by those skilled in the art utilizing the teachings of the present application. Not as an attempt to limit the application
20 of the doctrine of equivalents to the scope of the claims, each numerical parameter should at least be construed in light of the number of reported significant digits and by applying ordinary rounding techniques. Notwithstanding that the numerical ranges and parameters setting forth the broad scope of the invention are approximations, to the extent any numerical values are set forth in specific examples described herein, they are reported as
25 precisely as reasonably possible. Any numerical value, however, may well contain errors associated with testing or measurement limitations.

 Various modifications and alterations of this invention will be apparent to those skilled in the art without departing from the spirit and scope of this invention, and it should be understood that this invention is not limited to the illustrative embodiments set
30 forth herein. For example, the reader should assume that features of one disclosed embodiment can also be applied to all other disclosed embodiments unless otherwise indicated. It should also be understood that all U.S. patents, patent application

publications, and other patent and non-patent documents referred to herein are incorporated by reference, to the extent they do not contradict the foregoing disclosure.

CLAIMS

1. A film construction, comprising:

5 a plurality of microlayers configured to selectively transmit and reflect light as a function of angle and polarization over an extended wavelength region including visible wavelengths, the microlayers defining a pass axis for normally incident visible light of a first polarization and a block axis for normally incident visible light of a second polarization, the microlayers also
10 characterized by increased reflectivity at oblique angles so as to transmit visible light of the first polarization in a compressed viewing cone; and an optically thick low index layer having an ultra low refractive index coupled to the microlayers in such a way as to limit propagation of highly oblique light in the microlayers, or to redirect such highly oblique propagating light back
15 towards the microlayers.

2. The construction of claim 1, wherein the ultra low refractive index, averaged over visible wavelengths, is at least 1.1 but no more than 1.3.

20 3. The construction of claim 1, wherein the plurality of microlayers has a pass axis, a block axis, and a normal axis, and

wherein the plurality of microlayers has an average internal reflectivity over visible wavelengths, as a function of propagation angle θ , of: $RP_{\text{pass}}(\theta)$ for p-polarized light incident in a pass plane containing the pass axis and the normal axis; $RS_{\text{block}}(\theta)$ for s-polarized light incident in the pass plane; $RP_{\text{block}}(\theta)$ for p-polarized light incident in a block plane containing the block axis and the
25 normal axis; and $RS_{\text{pass}}(\theta)$ for s-polarized light incident in the block plane; wherein $R_{\text{block}}(\theta)$ is an average of $RS_{\text{block}}(\theta)$ and $RP_{\text{block}}(\theta)$, and $R_{\text{pass}}(\theta)$ is an average of $RS_{\text{pass}}(\theta)$ and $RP_{\text{pass}}(\theta)$;

30 wherein the plurality of microlayers has an average internal transmission over visible wavelengths, as a function of the propagation angle θ , of: $TP_{\text{pass}}(\theta)$ for p-polarized light incident in the pass plane; $TS_{\text{block}}(\theta)$ for s-polarized light

incident in the pass plane; TPblock(θ) for p-polarized light incident in the block plane; and TSpass(θ) for s-polarized light incident in the block plane; and

wherein Tblock(θ) is an average of TSblock(θ) and TPblock(θ), and Tpass(θ) is an average of TSpass(θ) and TPpass(θ).

5

4. The construction of claim 3, wherein Tblock(0) is less than 10%, and wherein Tpass(0) is in a range from 55% to 75%.

10

5. The construction of claim 4, wherein the propagation angle θ is an angle θ_{air} measured in air, and wherein $T_{\text{pass}}(\theta_{\text{air}} = 60^\circ) < 0.85 * T_{\text{pass}}(0)$.

15

6. The construction of claim 4, wherein the propagation angle θ is an angle $\theta_{\text{low index}}$ measured in the optically thick low index layer, and wherein $T_{\text{pass}}(\theta_{\text{low index}} = 90^\circ) < 0.6 * T_{\text{pass}}(0)$.

20

7. The construction of claim 1, further comprising:

a first and second optically thick layer arranged such that the optically thick low index layer and the plurality of microlayers are both disposed between the first and second optically thick layers;

wherein the first and second optically thick layers have higher refractive indices than that of the optically thick low index layer.

25

8. The construction of claim 7, wherein the first optically thick layer comprises a light guide.

9. The construction of claim 7, wherein the first optically thick layer comprises a diffusing layer.

30

10. The construction of claim 7, wherein the first optically thick layer comprises a display panel.

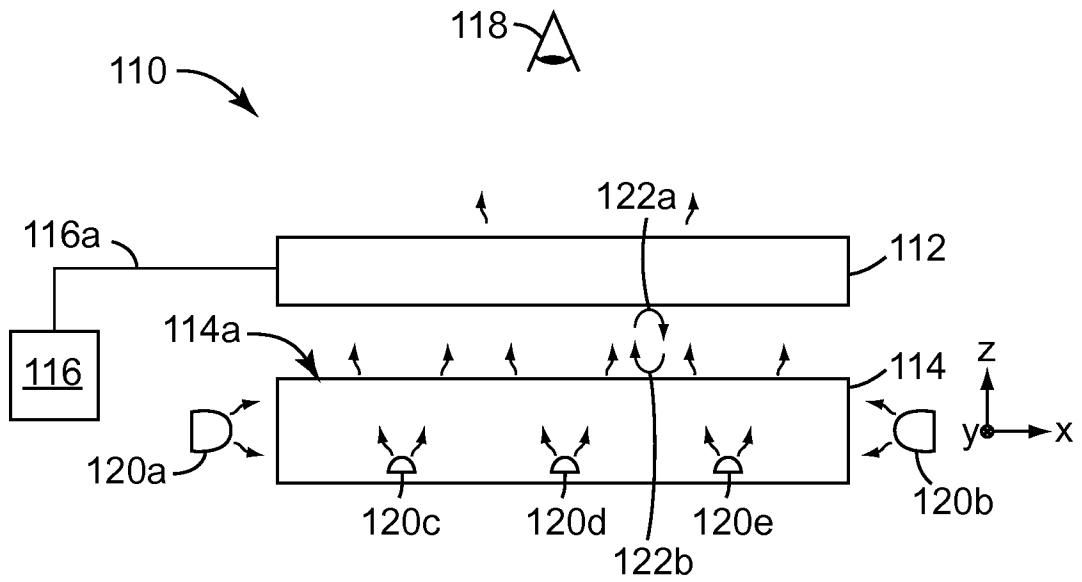

Fig. 1

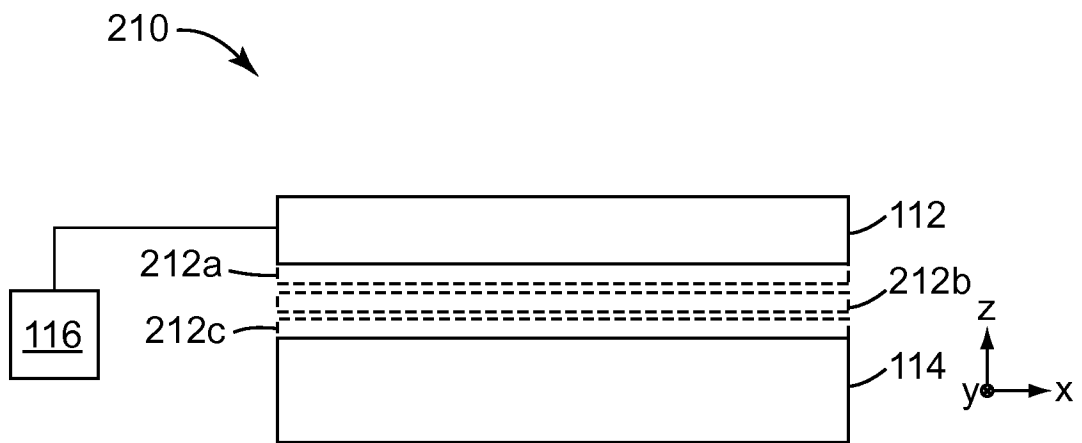

Fig. 2

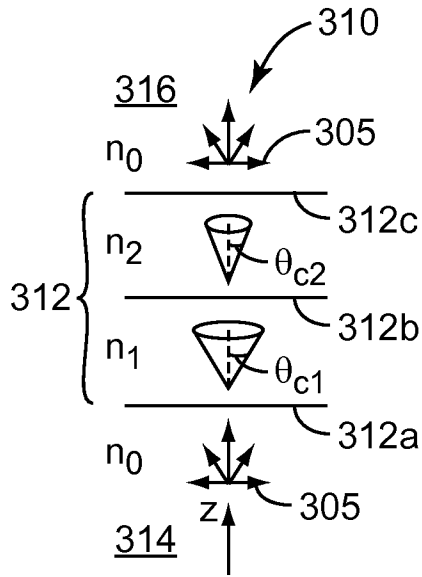

Fig. 3a

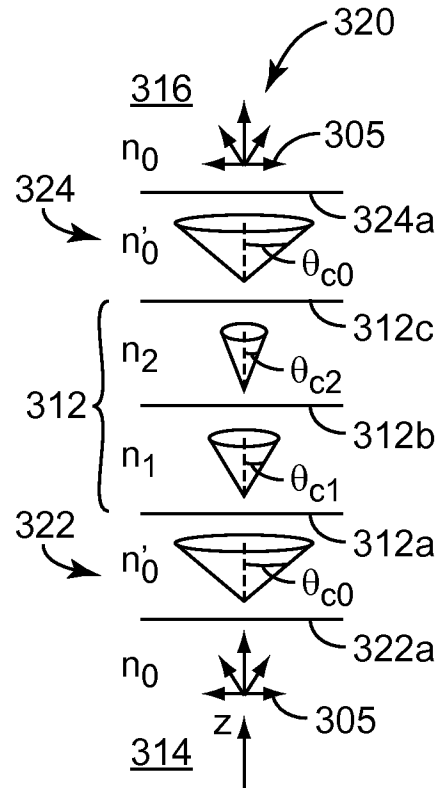

Fig. 3b

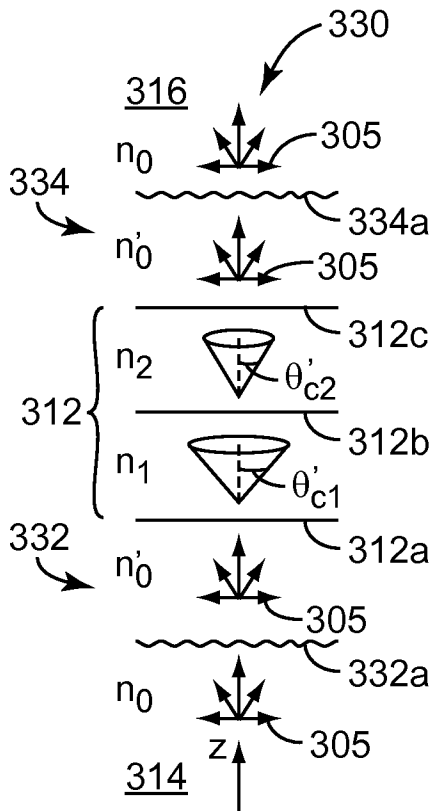

Fig. 3c

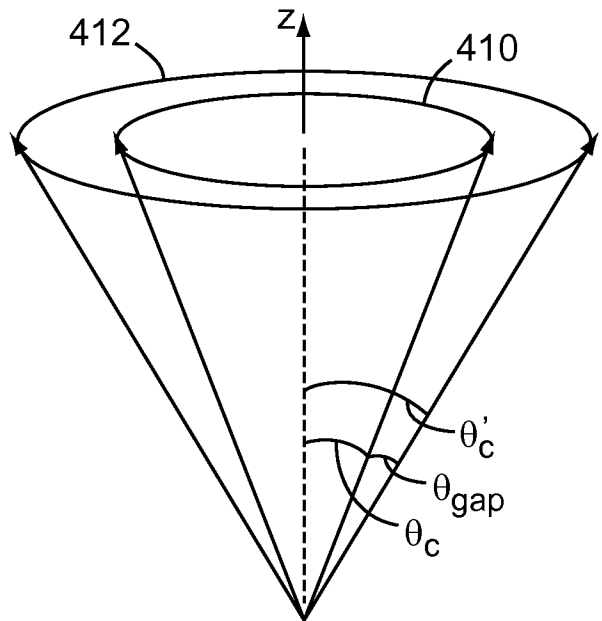

Fig. 4

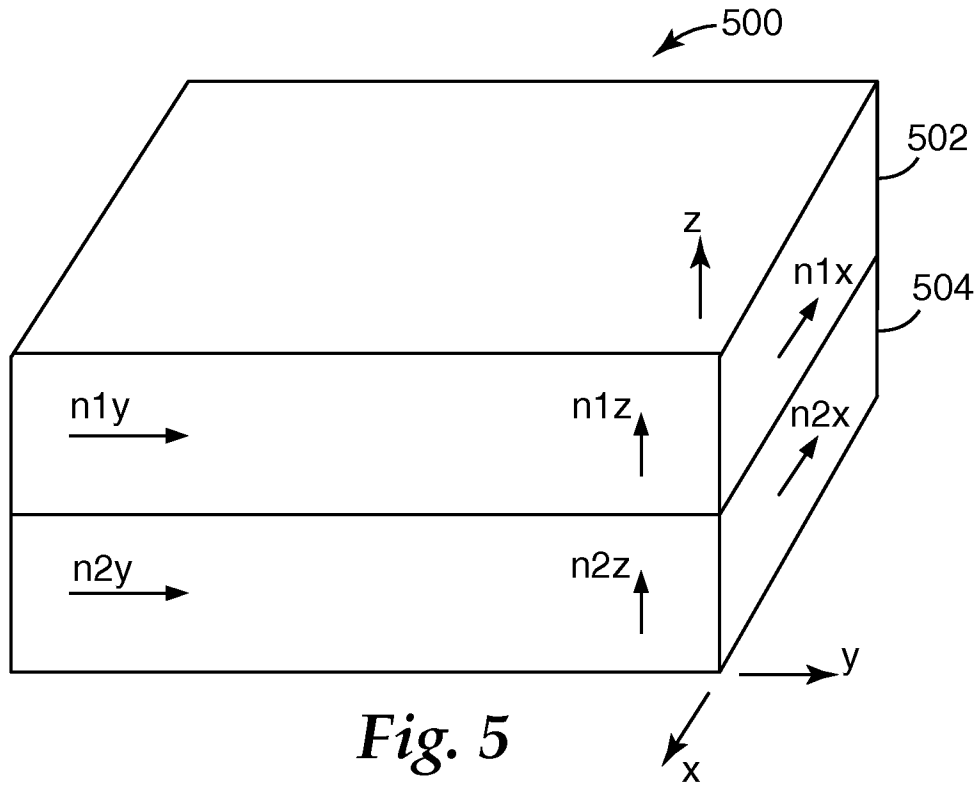

Fig. 5

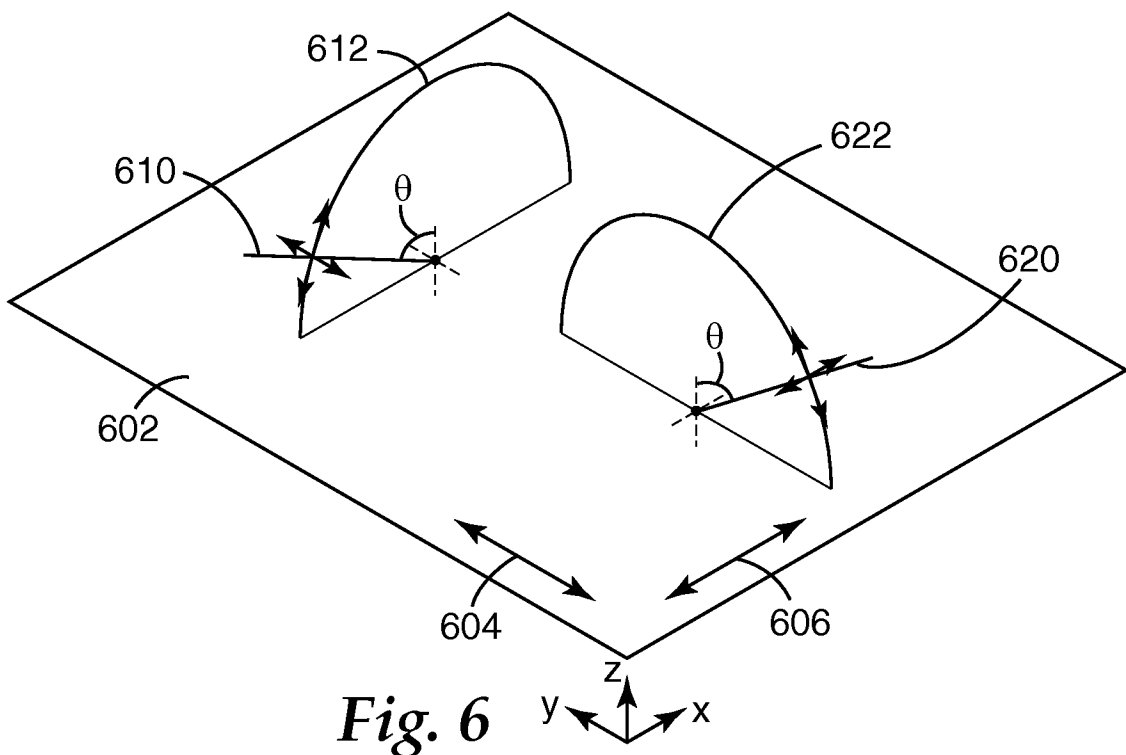
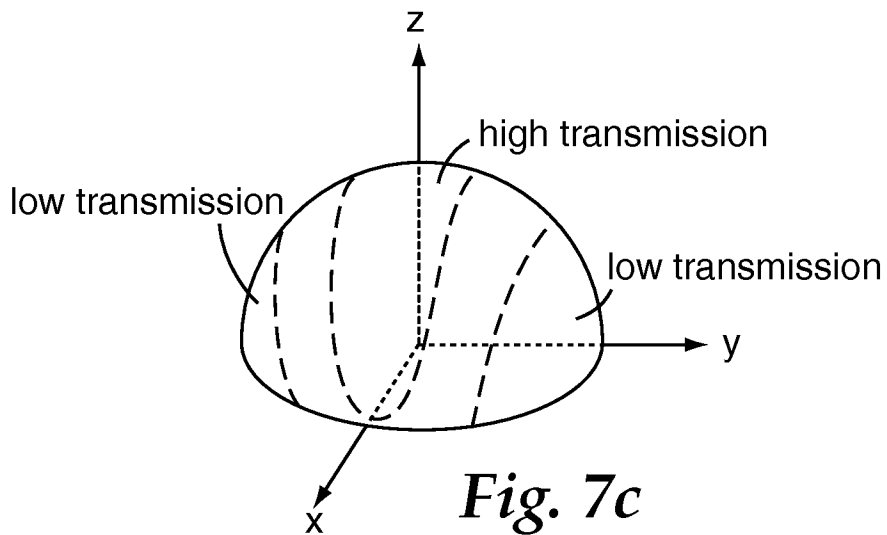
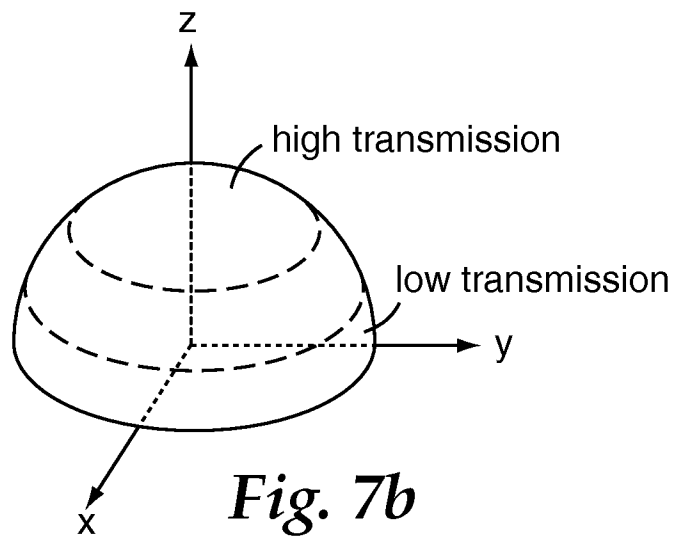
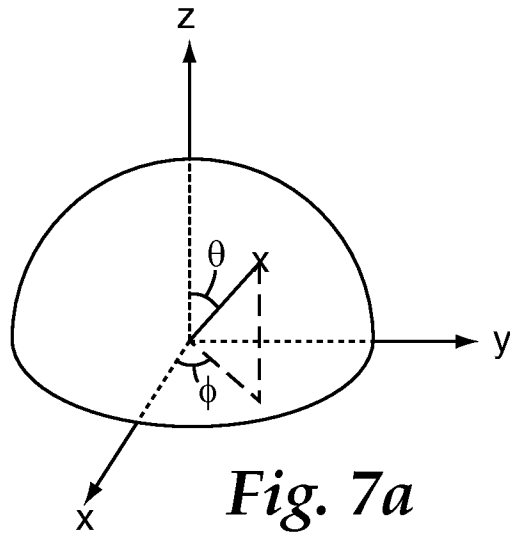

Fig. 6



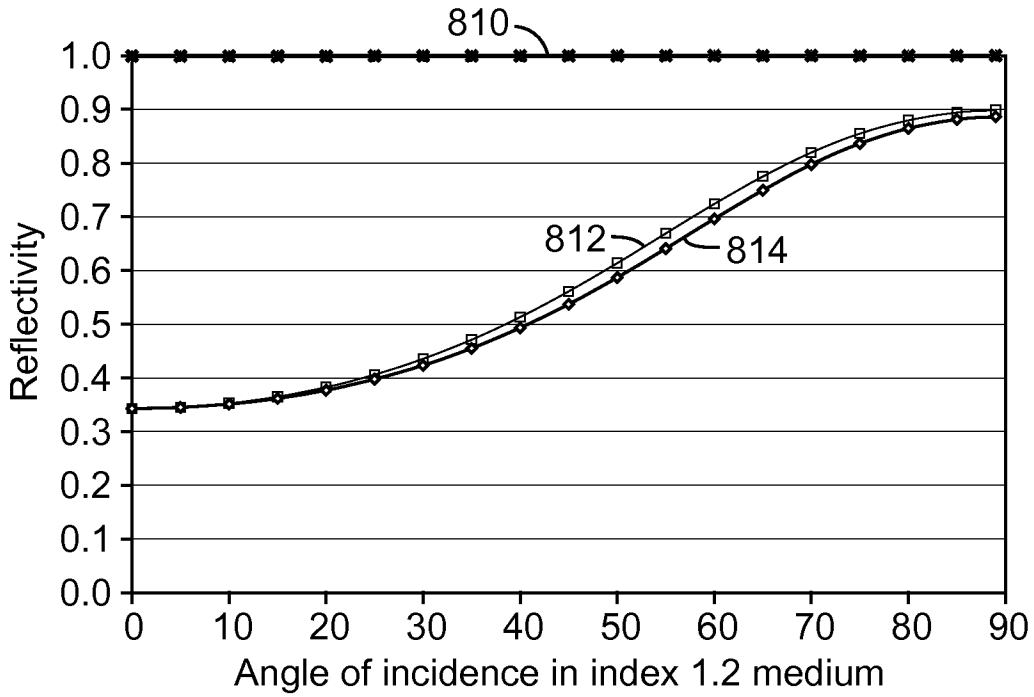

Fig. 8a

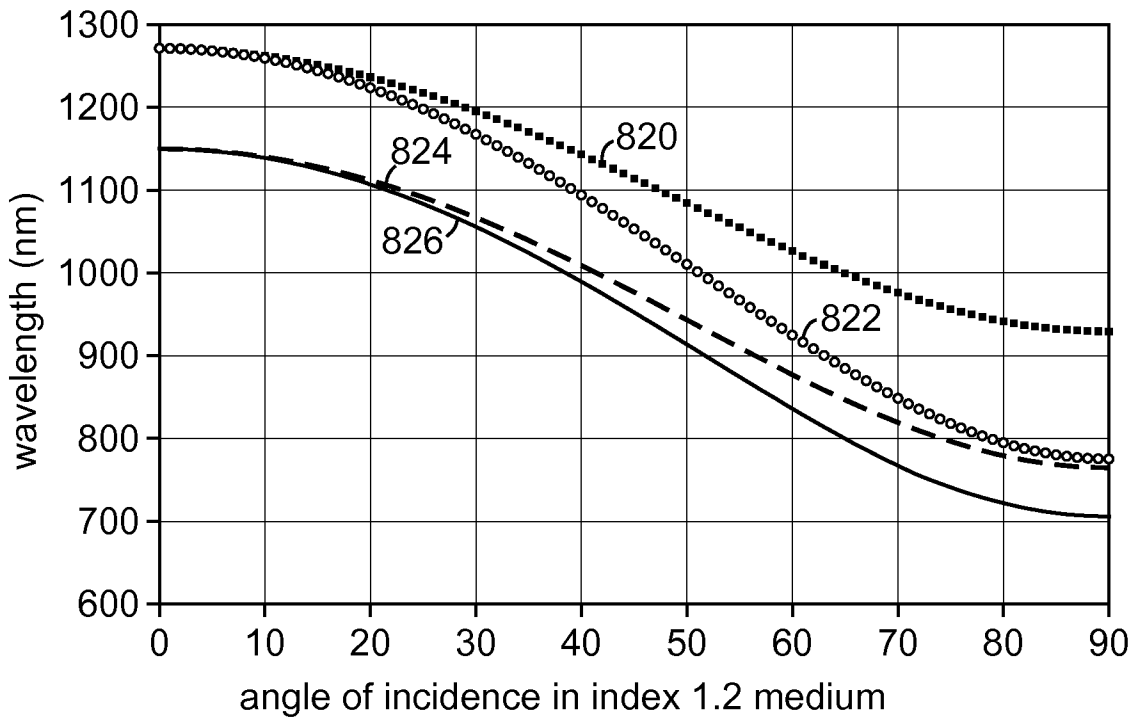

Fig. 8b

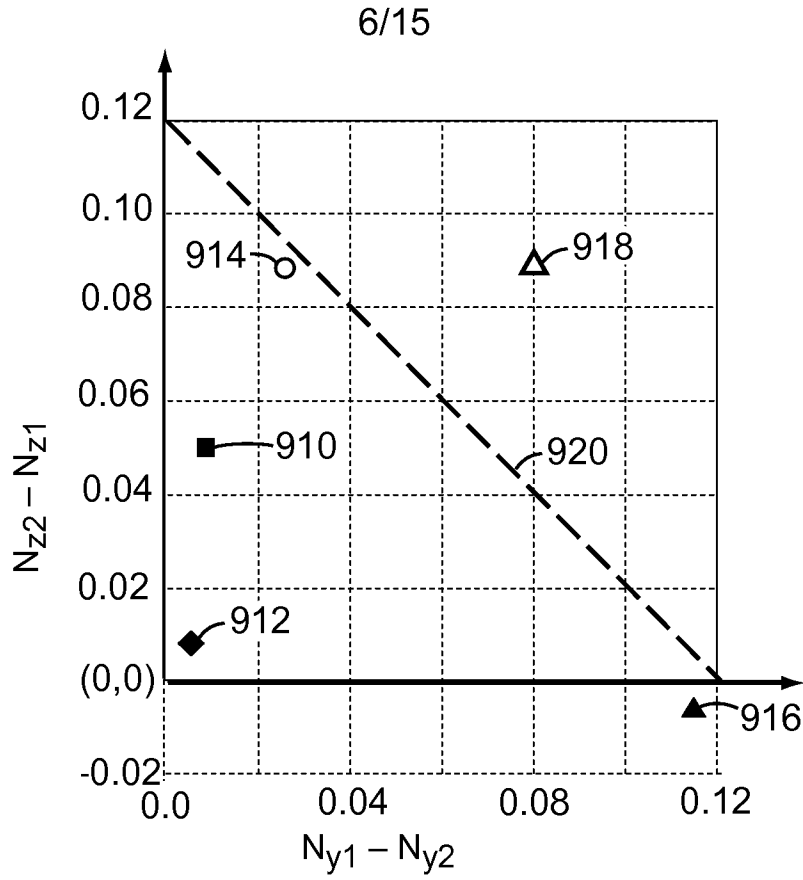

Fig. 9

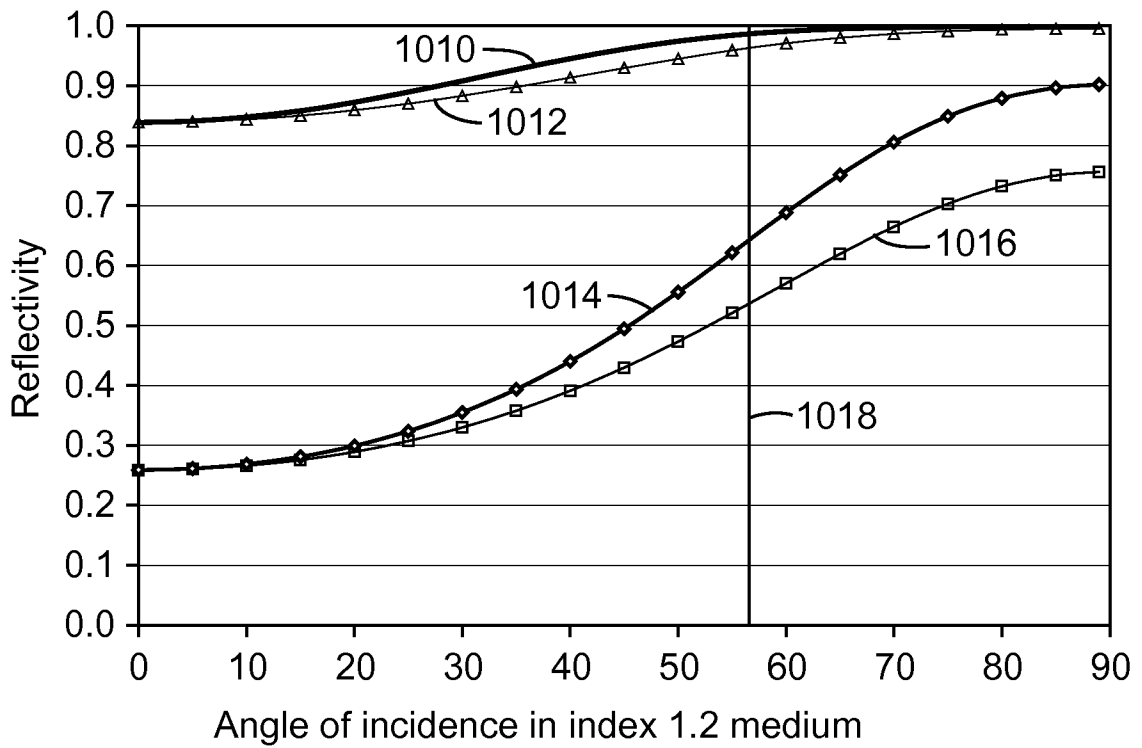

Fig. 10

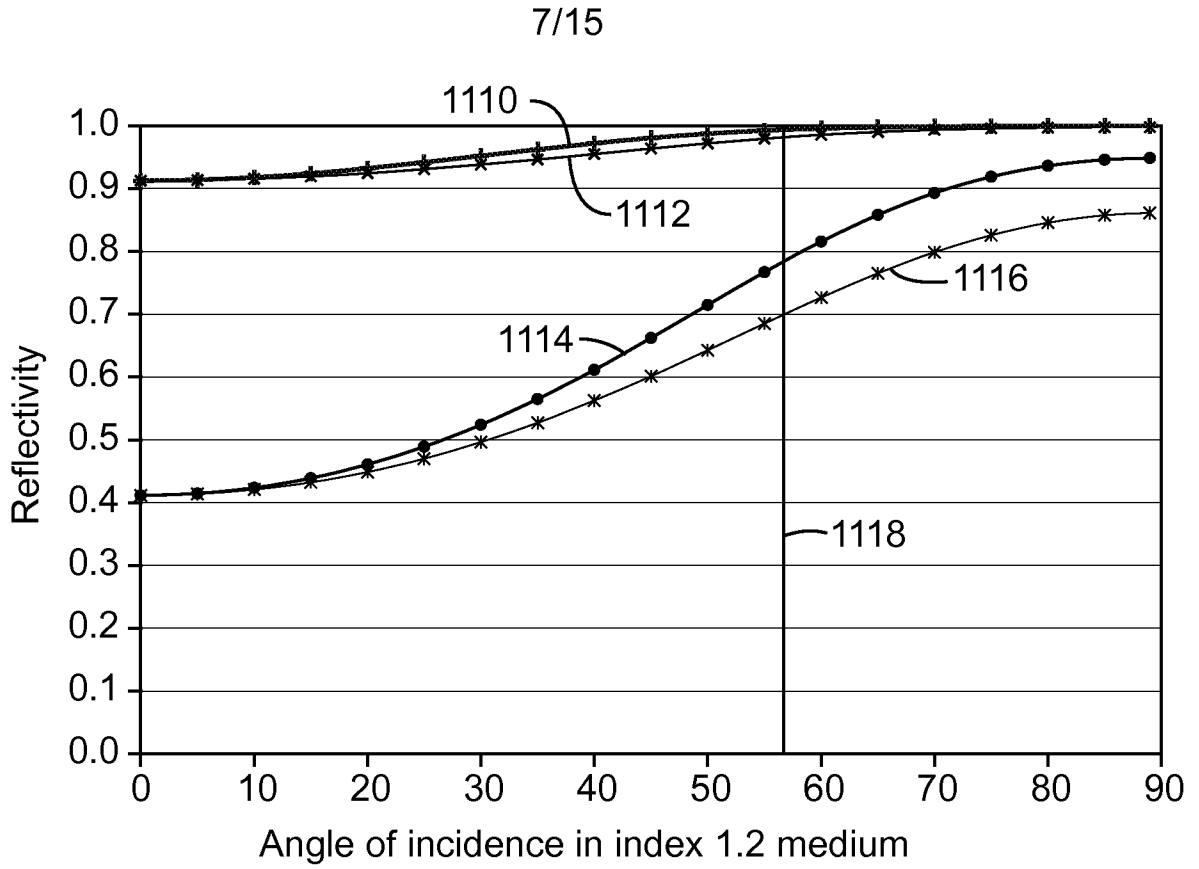

Fig. 11

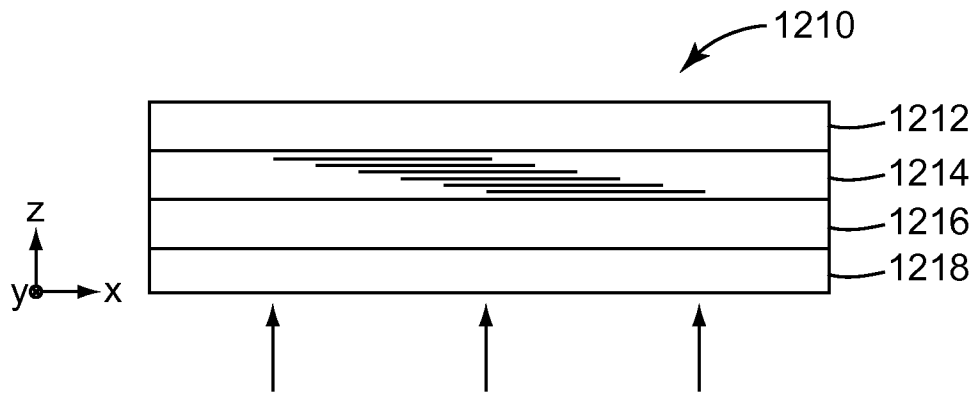

Fig. 12

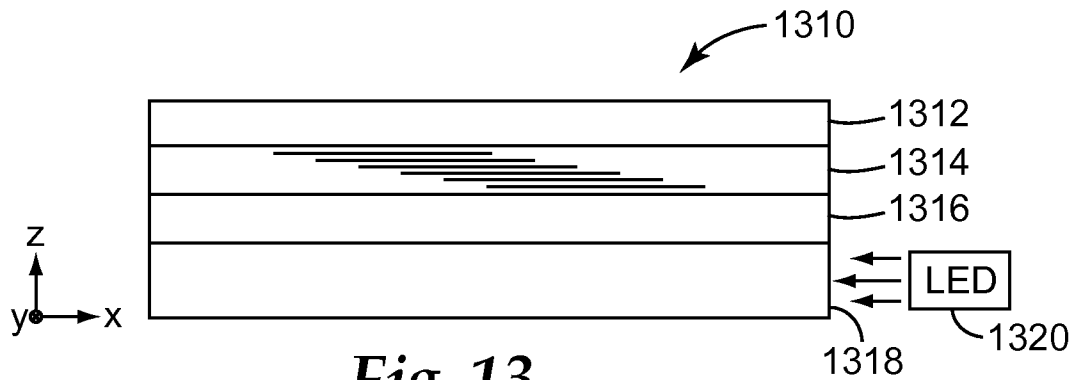

Fig. 13

8/15

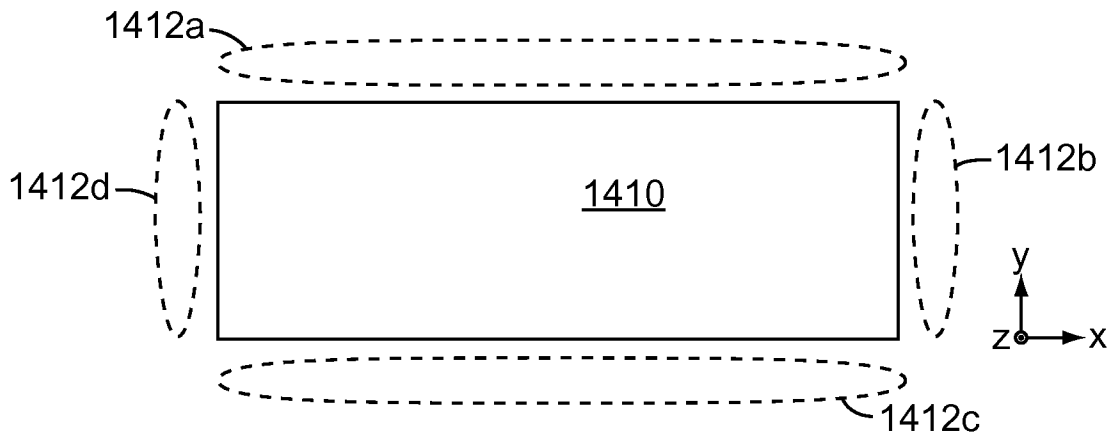

Fig. 14

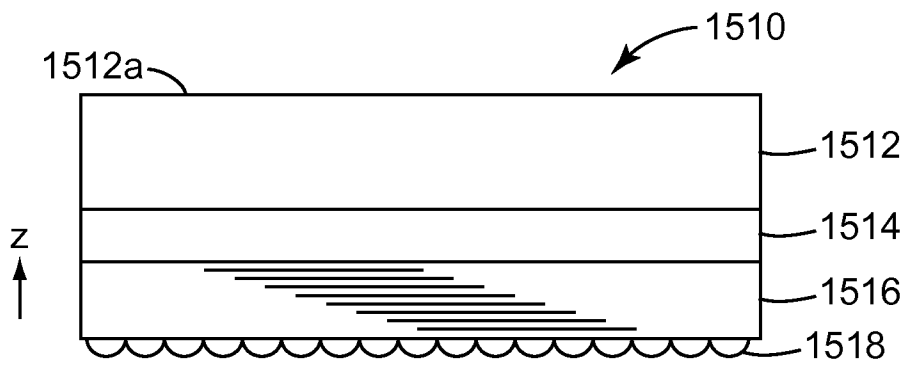

Fig. 15

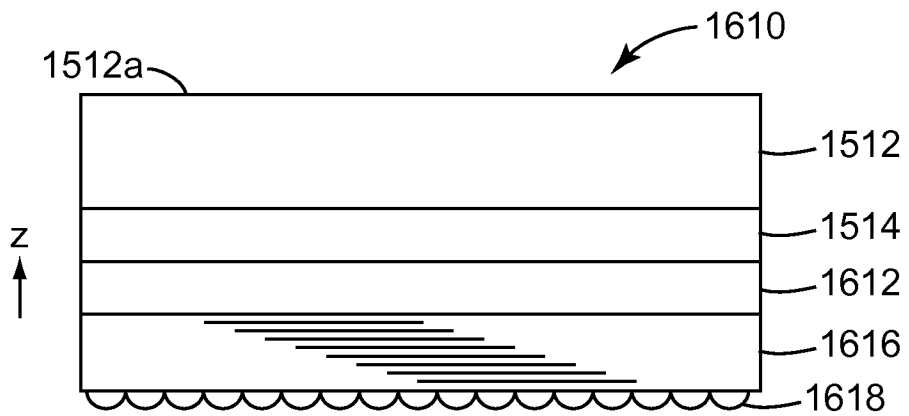

Fig. 16

9/15

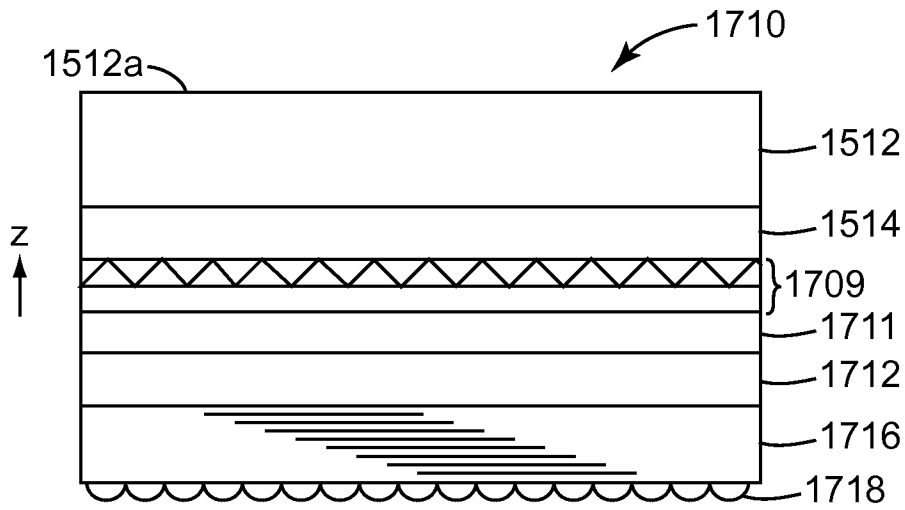

Fig. 17

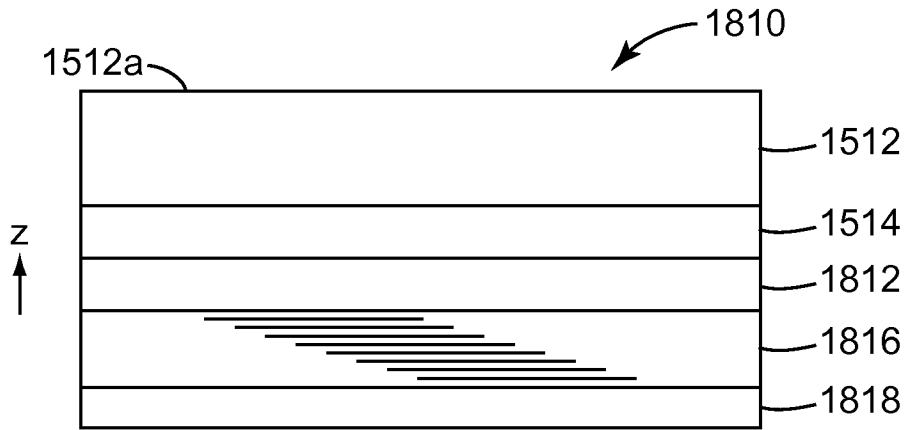

Fig. 18

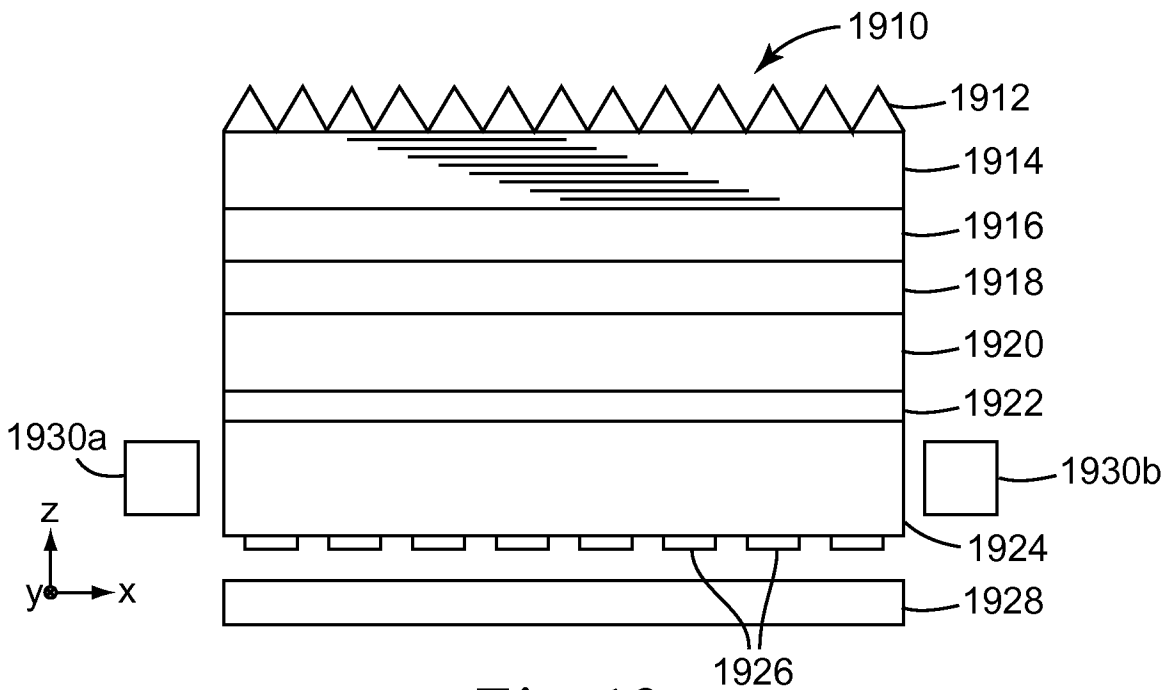

Fig. 19

10/15

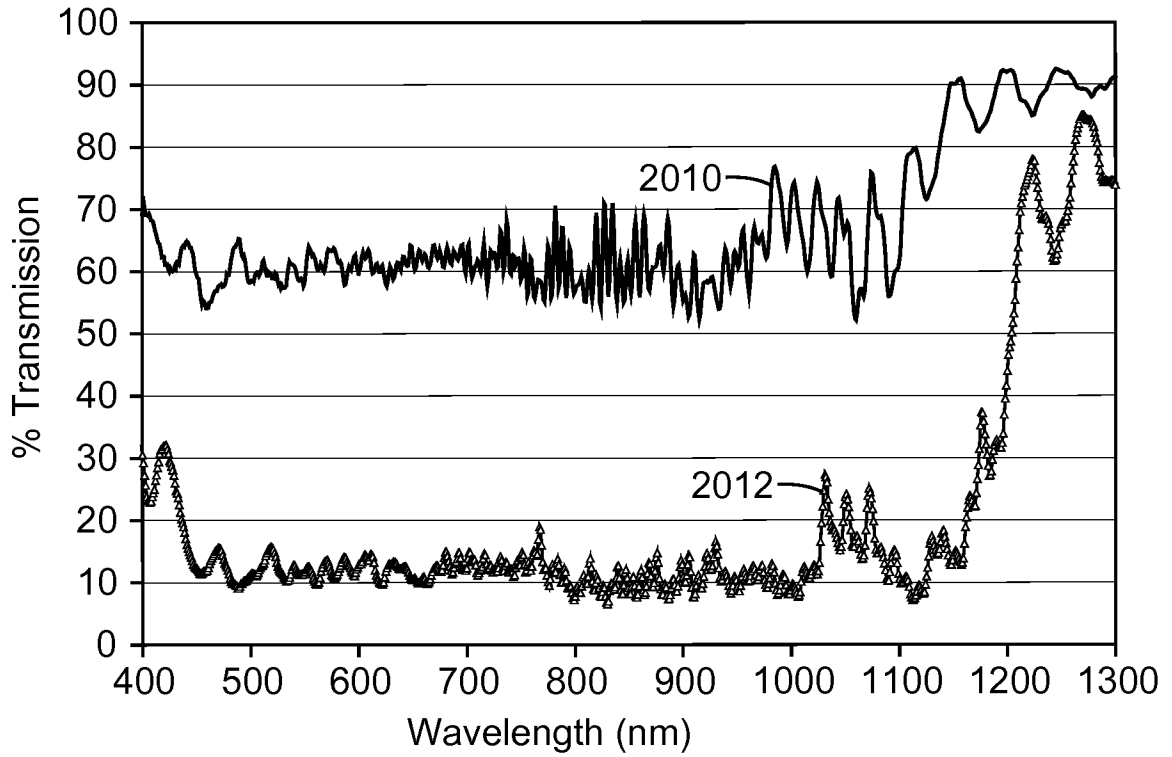

Fig. 20a

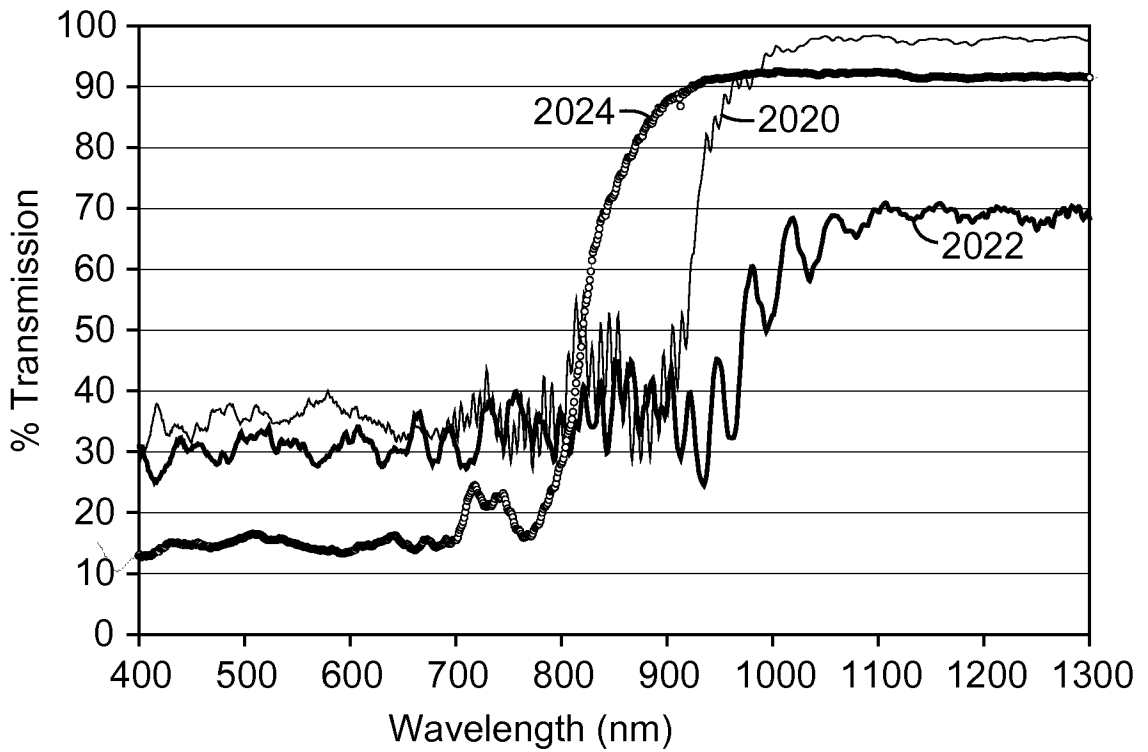

Fig. 20b

11/15

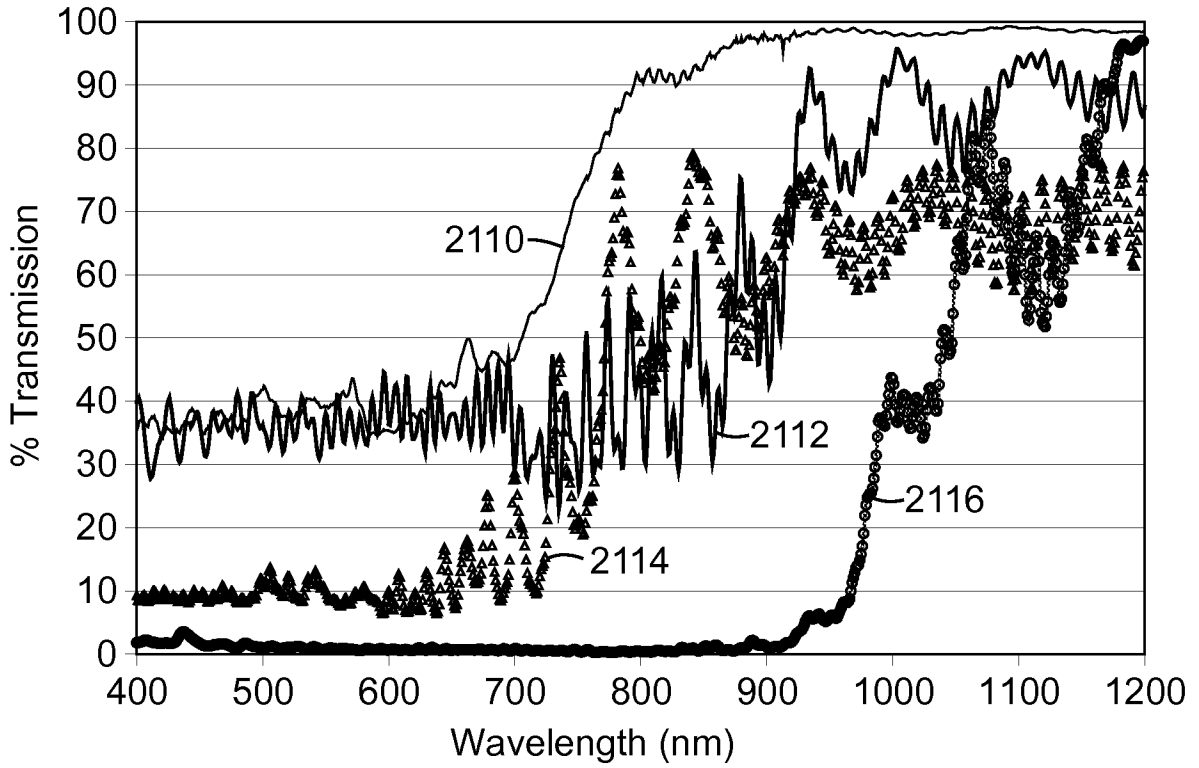

Fig. 21

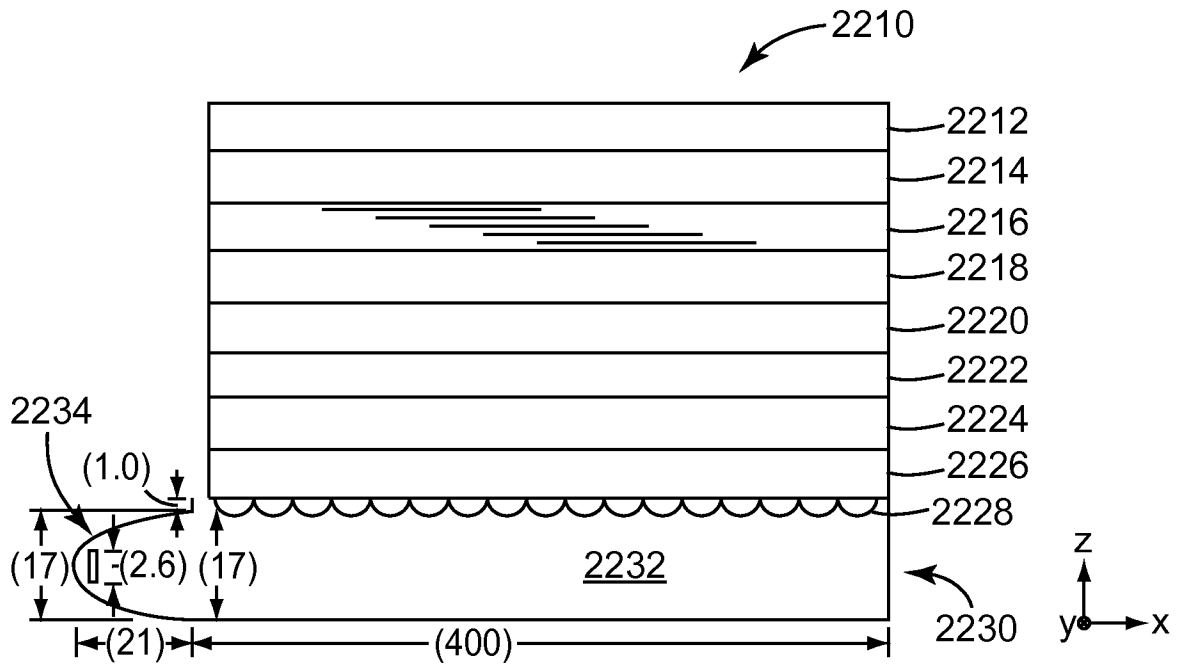

Fig. 22

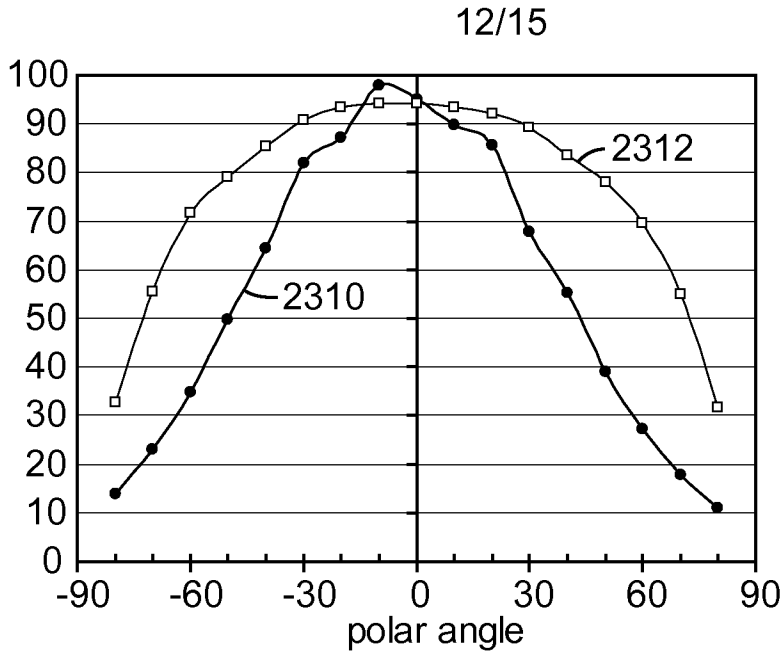

Fig. 23a

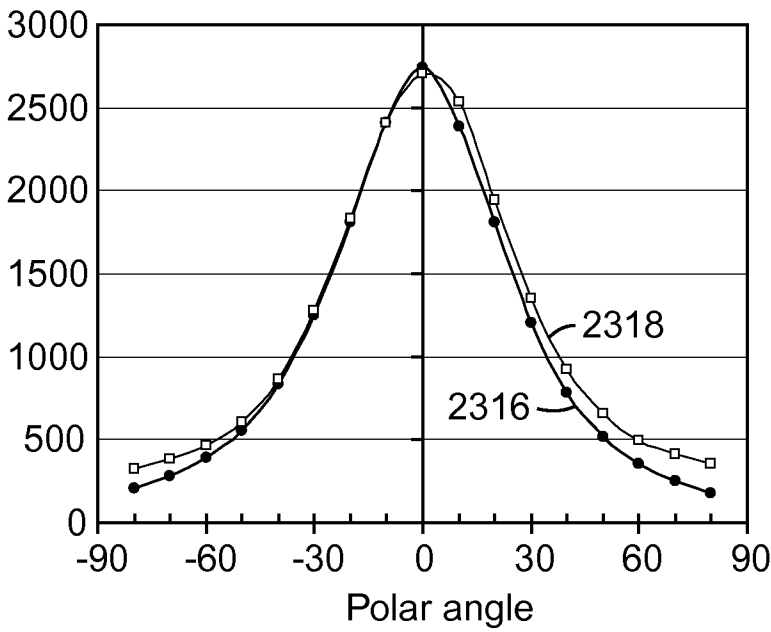

Fig. 23b

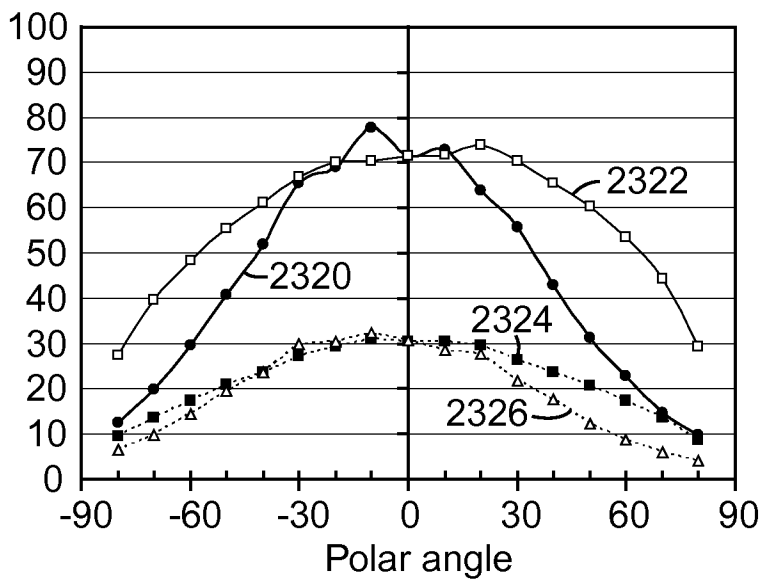

Fig. 23c

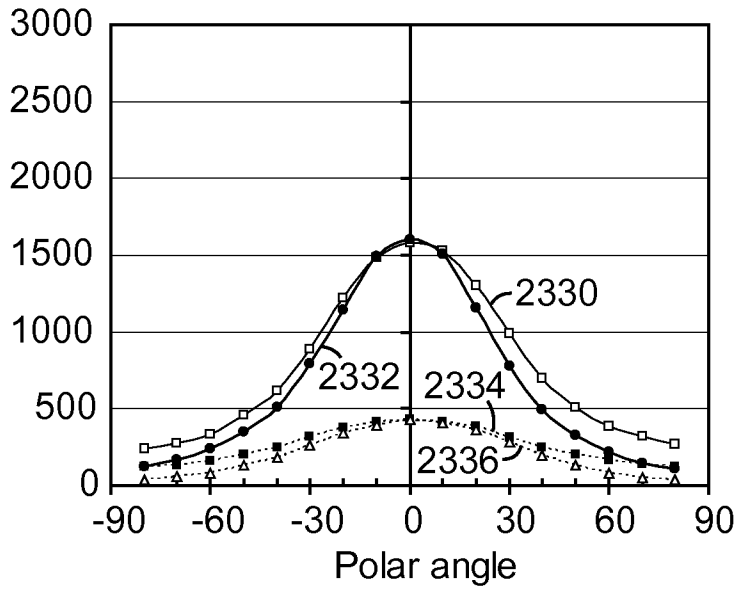

Fig. 23d

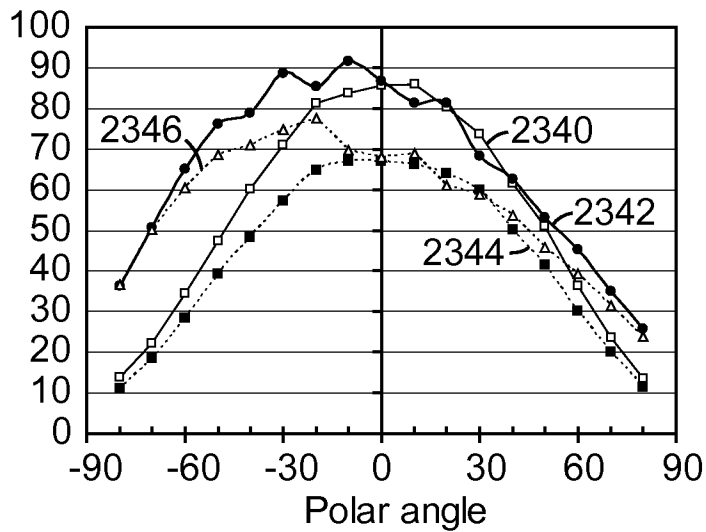

Fig. 23e

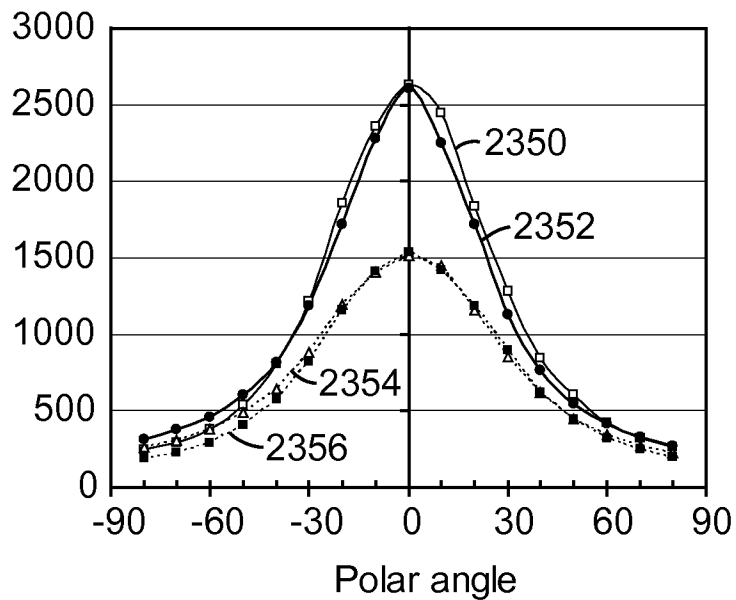

Fig. 23f

14/15

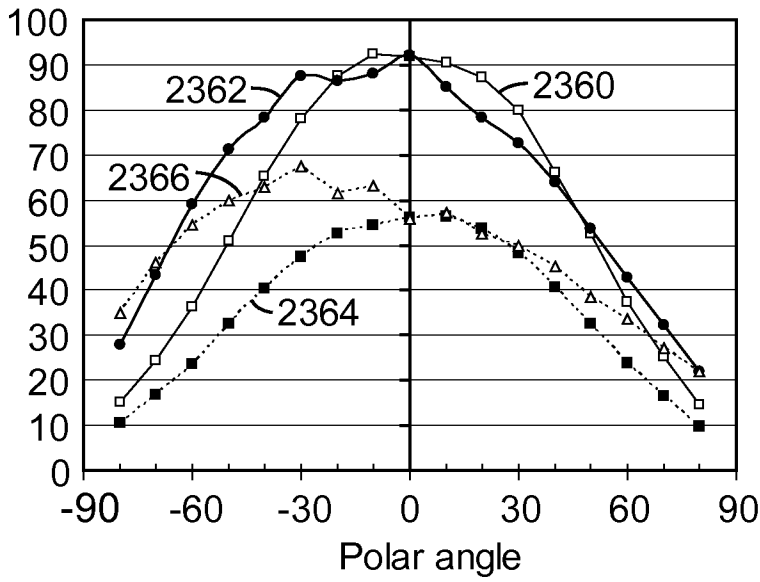

Fig. 23g

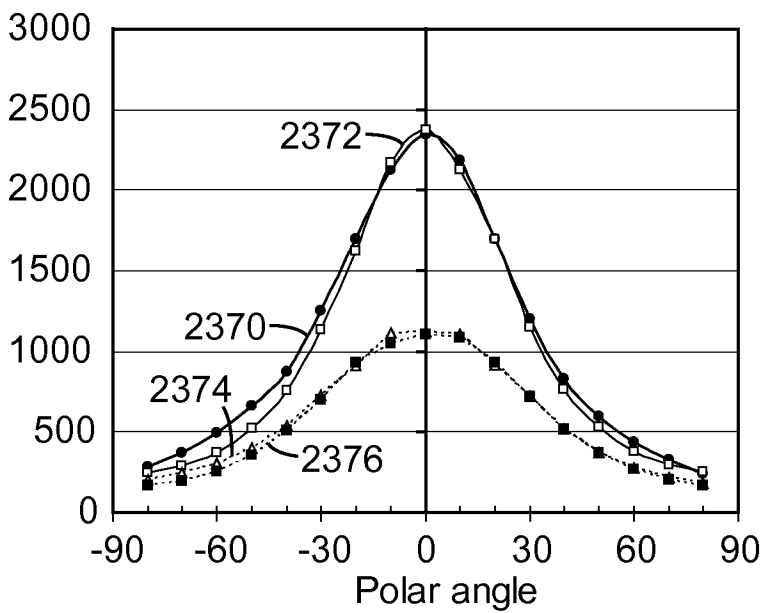

Fig. 23h

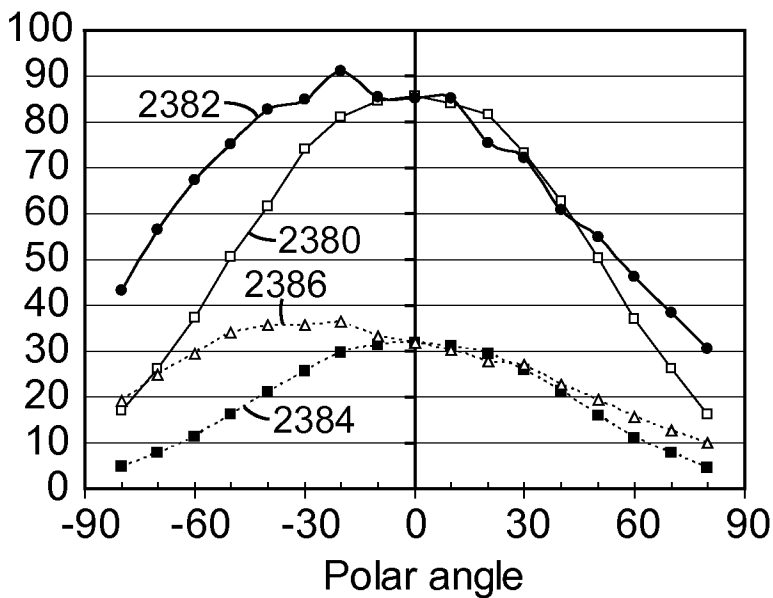

Fig. 23i

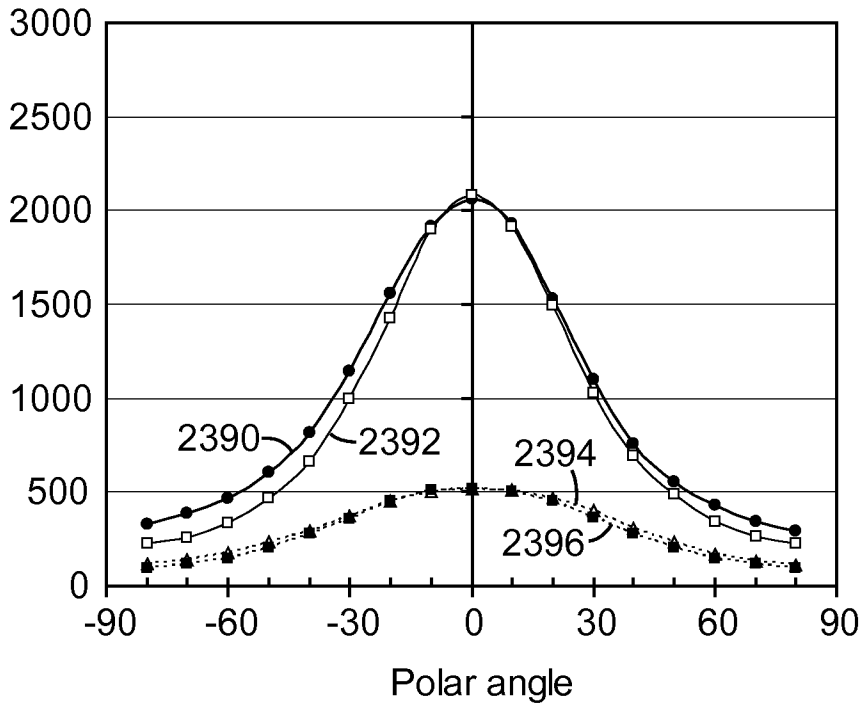

Fig. 23j

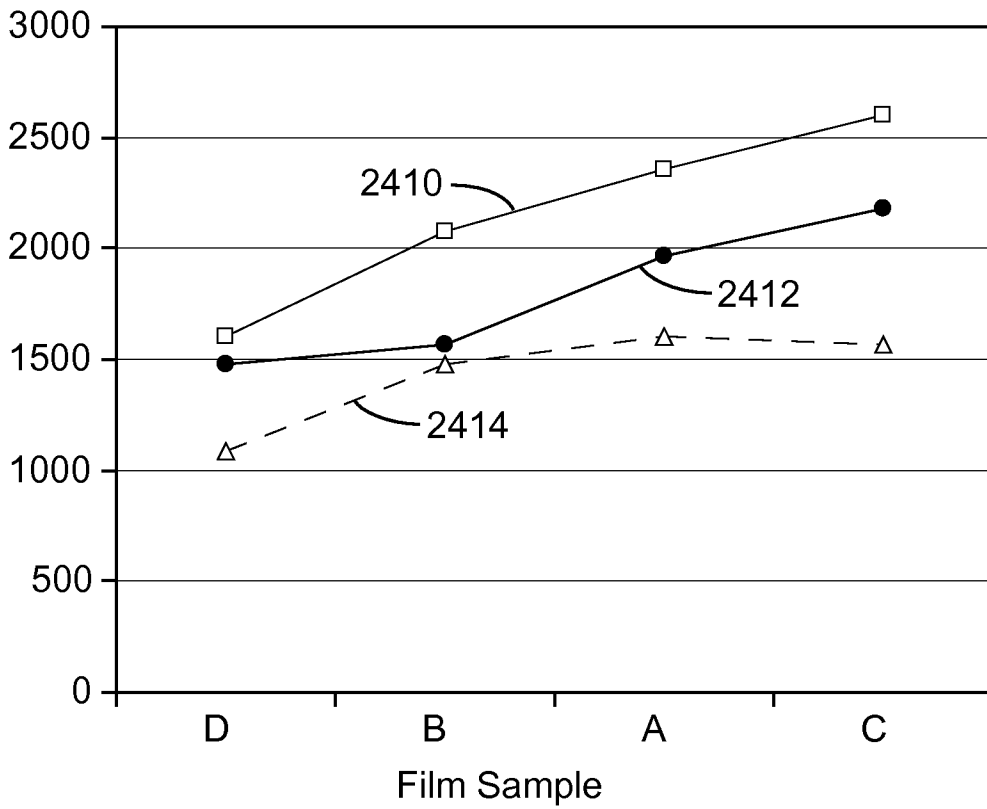

Fig. 24

INTERNATIONAL SEARCH REPORT

International application No
PCT/US2010/053751

A. CLASSIFICATION OF SUBJECT MATTER
INV. G02B5/30 G02F1/1335
ADD.
According to International Patent Classification (IPC) or to both national classification and IPC

B. FIELDS SEARCHED
Minimum documentation searched (classification system followed by classification symbols)
G02B G02F

Documentation searched other than minimum documentation to the extent that such documents are included in the fields searched

Electronic data base consulted during the international search (name of data base and, where practical, search terms used)
EPO-Internal

C. DOCUMENTS CONSIDERED TO BE RELEVANT

Category*	Citation of document, with indication, where appropriate, of the relevant passages	Relevant to claim No.
X	US 2008/037127 A1 (WEBER MICHAEL F [US]) 14 February 2008 (2008-02-14)	1-6
Y	paragraphs [0005], [0008], [0036], [0049], [0059] - [0062]; figures 4,9	1-10
Y	US 5 882 774 A (JONZA JAMES M [US] ET AL) 16 March 1999 (1999-03-16) cited in the application column 12, line 34 - line 42	1-6
X,P	WO 2010/120971 A1 (3M INNOVATIVE PROPERTIES CO [US]; HAO ENCAI [US]; LU FEI [US]; KOLB WI) 21 October 2010 (2010-10-21) page 13, line 28; figure 1 page 7, line 8 - line 24	1,2
	----- -/--	

Further documents are listed in the continuation of Box C.

See patent family annex.

* Special categories of cited documents :

- "A" document defining the general state of the art which is not considered to be of particular relevance
- "E" earlier document but published on or after the international filing date
- "L" document which may throw doubts on priority claim(s) or which is cited to establish the publication date of another citation or other special reason (as specified)
- "O" document referring to an oral disclosure, use, exhibition or other means
- "P" document published prior to the international filing date but later than the priority date claimed

- "T" later document published after the international filing date or priority date and not in conflict with the application but cited to understand the principle or theory underlying the invention
- "X" document of particular relevance; the claimed invention cannot be considered novel or cannot be considered to involve an inventive step when the document is taken alone
- "Y" document of particular relevance; the claimed invention cannot be considered to involve an inventive step when the document is combined with one or more other such documents, such combination being obvious to a person skilled in the art.
- "&" document member of the same patent family

Date of the actual completion of the international search 8 March 2011	Date of mailing of the international search report 18/03/2011
Name and mailing address of the ISA/ European Patent Office, P.B. 5818 Patentlaan 2 NL - 2280 HV Rijswijk Tel. (+31-70) 340-2040, Fax: (+31-70) 340-3016	Authorized officer Hornung, André

INTERNATIONAL SEARCH REPORT

International application No
PCT/US2010/053751

C(Continuation). DOCUMENTS CONSIDERED TO BE RELEVANT

Category*	Citation of document, with indication, where appropriate, of the relevant passages	Relevant to claim No.
Y	US 2006/082699 A1 (GEHLSSEN MARK D [US] ET AL) 20 April 2006 (2006-04-20) paragraphs [0003], [0042] - [0050], [0076], [0078]; figures 1,4C -----	1,7-10

INTERNATIONAL SEARCH REPORT

International application No.
PCT/US2010/053751

Box No. II Observations where certain claims were found unsearchable (Continuation of item 2 of first sheet)

This international search report has not been established in respect of certain claims under Article 17(2)(a) for the following reasons:

1. Claims Nos.:
because they relate to subject matter not required to be searched by this Authority, namely:

2. Claims Nos.:
because they relate to parts of the international application that do not comply with the prescribed requirements to such an extent that no meaningful international search can be carried out, specifically:

3. Claims Nos.:
because they are dependent claims and are not drafted in accordance with the second and third sentences of Rule 6.4(a).

Box No. III Observations where unity of invention is lacking (Continuation of item 3 of first sheet)

This International Searching Authority found multiple inventions in this international application, as follows:

see additional sheet

1. As all required additional search fees were timely paid by the applicant, this international search report covers all searchable claims.

2. As all searchable claims could be searched without effort justifying an additional fees, this Authority did not invite payment of additional fees.

3. As only some of the required additional search fees were timely paid by the applicant, this international search report covers only those claims for which fees were paid, specifically claims Nos.:

4. No required additional search fees were timely paid by the applicant. Consequently, this international search report is restricted to the invention first mentioned in the claims; it is covered by claims Nos.:

Remark on Protest

- The additional search fees were accompanied by the applicant's protest and, where applicable, the payment of a protest fee.
- The additional search fees were accompanied by the applicant's protest but the applicable protest fee was not paid within the time limit specified in the invitation.
- No protest accompanied the payment of additional search fees.

INTERNATIONAL SEARCH REPORT

Information on patent family members

International application No

PCT/US2010/053751

Patent document cited in search report	Publication date	Patent family member(s)	Publication date
US 2008037127	A1	14-02-2008	
		CN 101432641 A	13-05-2009
		EP 2033025 A2	11-03-2009
		JP 2009532720 T	10-09-2009
		KR 20080108255 A	12-12-2008
		US 2008291361 A1	27-11-2008
		WO 2007115040 A2	11-10-2007

US 5882774	A	16-03-1999	NONE

WO 2010120971	A1	21-10-2010	NONE

US 2006082699	A1	20-04-2006	
		EP 1800179 A2	27-06-2007
		JP 2008517328 T	22-05-2008
		KR 20070068454 A	29-06-2007
		US 2010188754 A1	29-07-2010
		WO 2006044475 A2	27-04-2006

FURTHER INFORMATION CONTINUED FROM PCT/ISA/ 210

This International Searching Authority found multiple (groups of) inventions in this international application, as follows:

1. claims: 1-6

Film construction comprising a plurality of multilayers selectively transmitting and reflecting light as a function of angle and polarization and a thick layer whose index is between 1.1 and 1.3, and wherein transmission values fulfill certain numerical conditions.

2. claims: 7-10

Film construction comprising a plurality of multilayers selectively transmitting and reflecting light as a function of angle and polarization, a thick low index layer and two further optically thick layer.
