

Aug. 8, 1961

A. W. KAWALLE

2,995,646

REMOVABLE TYPE ELECTRIC HEATING ELEMENT

Filed Feb. 26, 1959

2 Sheets-Sheet 1

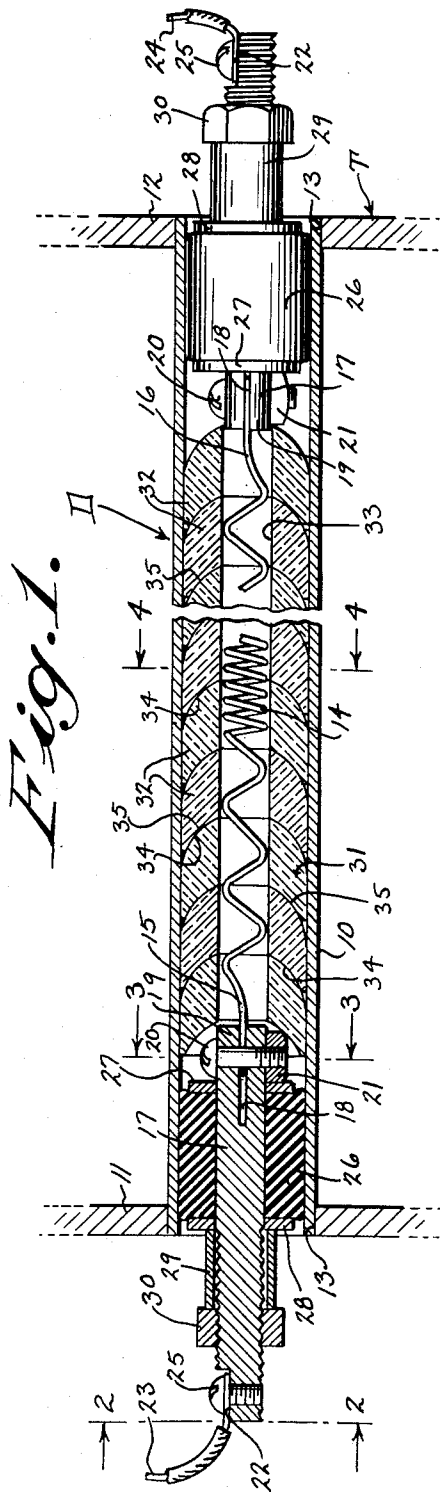

Fig. 1.

Fig. 4.

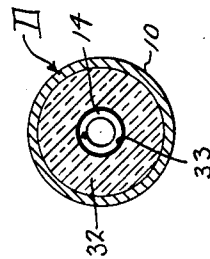

Fig. 3.

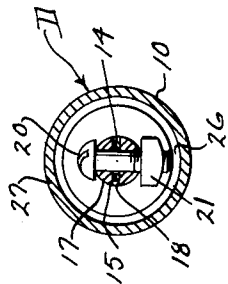
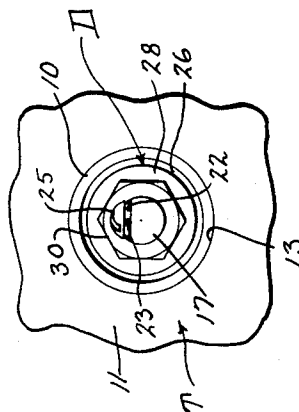

Fig. 2.



INVENTOR
ARTHUR W. KAWALLE

BY *Wright Wright*

ATTORNEYS

Aug. 8, 1961

A. W. KAWALLE

2,995,646

REMOVABLE TYPE ELECTRIC HEATING ELEMENT

Filed Feb. 26, 1959

2 Sheets-Sheet 2

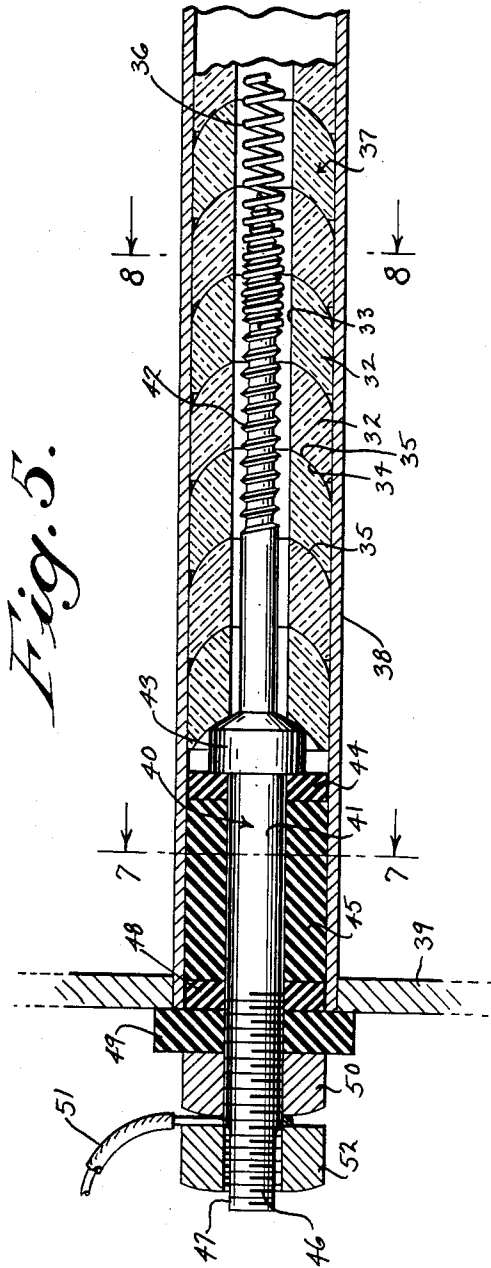
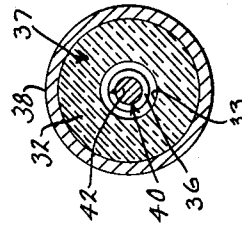
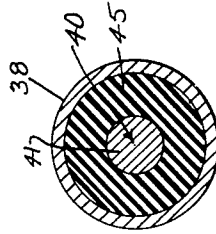
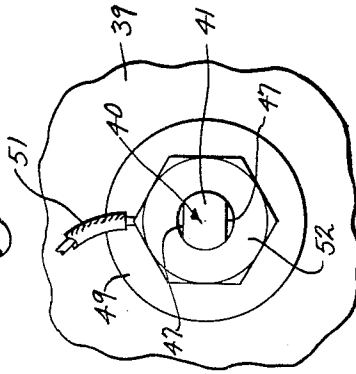

Fig. 5.

Fig. 6. Fig. 7. Fig. 8.



INVENTOR
ARTHUR W. KAWALLE

BY *Wright Wright*

ATTORNEYS

1

2,995,646

REMOVABLE TYPE ELECTRIC HEATING ELEMENT

Arthur W. Kawalle, 2415 S. 10th St., Manitowoc, Wis.
 Filed Feb. 26, 1959, Ser. No. 795,764
 2 Claims. (Cl. 219-38)

This invention appertains to electric heating elements and mountings therefor, and more particularly to a removable, horizontal type electric heating element for water tanks and other installations.

One of the primary objects of my invention is to provide means for sealing and supporting an electric heating element within a protecting tube, whereby the following advantages will be had: (1) the heating element will operate within a non-oxidizing atmosphere; (2) will prevent the attraction of moisture to the electric element and its adjuncts so that electric shorts from condensation will be prevented, and, (3) whereby the heating element can operate at a pressure higher than gravity and thus promote better heat conductivity.

Another salient object of my invention is to provide means whereby the heating element can be quickly removed and replaced without disturbing the mounting of the protecting tube so that different characters of elements can be interchangeably used and so that burned out elements can be readily replaced.

A further important object of my invention is the provision of novel end mountings for the heating element embodying terminal connector studs or bolts for firmly receiving the ends of the element and for supporting expansion plugs of non-electric material for tight sealing engagement with the inner surfaces of the protecting tube, with means for expanding the plugs on the terminal studs or bolts, the terminal studs or bolts having means at the outer ends thereof for connection with electric lead wires.

A still further object of my invention is the provision of a novel sectional insulator for receiving and protecting the heating element and for extending from one terminal stud or bolt to the other, the insulator engaging the inner surface of the protecting tube, whereby to prevent accidental engagement with the tube and heating element.

A still further important object of my invention is to provide an electric heating element and mounting therefor, which will be durable and efficient in use, one that will be simple and easy to manufacture, and one which can be placed upon the market at a reasonable cost.

With these and other objects in view, the invention consists in the novel construction, arrangement and formation of parts, as will be hereinafter more specifically described and claimed, and illustrated in the accompanying drawings, in which drawings,

FIGURE 1 is a longitudinal sectional view through my improved electric heating device, the same being shown mounted within a tank for heating hot water or other liquids;

FIGURE 2 is a fragmentary end elevational view of the improved electric heating device, with a part in section, the section being taken on the line 2-2 of FIGURE 1, looking in the direction of the arrows;

FIGURE 3 is a transverse sectional view through the electric heating device taken on the line 3-3 of FIGURE 1, looking in the direction of the arrows, and illustrating the novel means of clamping one end of the electric heating element to a terminal stud or bolt;

FIGURE 4 is a transverse sectional view through the electric heating device taken on the line 4-4 of FIGURE 1, looking in the direction of the arrows, the view illustrating, more particularly, the novel insulator and protector for the heating element;

2

FIGURE 5 is a fragmentary longitudinal sectional view showing a modified form of mounting for the electric heating element;

FIGURE 6 is an end elevational view of the form of the electric heating element shown in FIGURE 5;

FIGURE 7 is a transverse sectional view taken on the line 7-7 of FIGURE 5, looking in the direction of the arrows, the view showing the mounting of the expansion plug on the terminal stud or bolt, and

FIGURE 8 is a transverse sectional view taken on the line 8-8 of FIGURE 5, looking in the direction of the arrows, showing the novel insulator and the modified form of connecting the electric heating element with the terminal stud or bolt.

Referring to the drawings in detail, wherein similar reference characters designate corresponding parts throughout the several views, the letter D generally indicates my improved heating device, and the same includes an elongated protector tube 10 formed from heat conducting material, such as copper. The tube 10 should also be of a character that will not corrode when immersed in liquids. In FIGURE 1, I have shown one use of the electric heating device, namely, within a tank T for heating liquids. As shown, the tank T includes opposite side walls 11 and 12. In the showing, I have illustrated a straight tube, but it is also to be understood that the tube can be of an arcuate shape should such be desired. It is to be also understood that the use of the electric heating device is not limited to hot water heaters, but also can be effectively used in baseboards for heating rooms and buildings.

Where the heating device D is used with a tank T the terminals of the tube 10 are welded or otherwise rigidly secured in liquid tight engagement with the walls 11 and 12 of the tank. The terminals of the tube extend through openings 13 in said walls and due to the construction and arrangement of my device, the terminals of the tube can end flush with the outer surface of the walls of the tank.

Mounted within the tube 10 is an electric heating element 14 and this element is preferably coiled to increase the efficiency thereof with the terminals 15 and 16 thereof stretched substantially straight, for a purpose which will later appear. The heating element 14 can be of various characters and types according to the voltage and wattage of the current being used and the work to be done. Arranged at the ends 15 and 16 of the heating element 14 and at the ends of the tube 10 are centrally disposed electric conducting terminal studs or bolts 17. The inner ends of the bolts are bifurcated or slotted, as at 18, to provide clamping jaws 19 which receive therebetween the stretched terminals 15 and 16 of the heating elements 14. Headed bolts 20 are passed diametrically through the slotted ends of the terminal studs or bolts and the ends of the heating element can be hooked or coiled around the intermediate portions of the bolts 20. Nuts 21 are threaded on the bolts and can be tightened into intimate contact with the inner slotted ends of the bolts 17 so as to force the jaws 19 into intimate gripping contact with the ends of the heating element. The outer ends of the terminal bolts 17 can be threaded and provided with a flattened portion 22 for receiving the inner ends of electric conducting lead wires 23 and 24, which can lead to any suitable source of electrical energy. Headed screws 25 threaded into the ends of the terminal bolts 17 can be utilized for holding the inner ends of the lead wire in electrical engagement with the terminal studs or bolts 17.

Mounted upon the terminal studs or bolts 17 are expansion plugs 26 formed from non-electric conducting material. The inner ends of the plugs can rest against washers 27 placed on said terminal studs or bolts 17, and

these washers rest against nuts 21 and limit the inward movement of the washers 27 and the expansion plugs on said terminal bolts or studs 17. The plugs 26 have a normal diameter substantially equal to the internal diameter of the tube 10 so that the plugs can be slipped into the ends of the tube. Also mounted on the terminal studs or bolts 17 are outer washers 28 which engage the outer faces of the plugs 26. Spacer sleeves 29 are placed on the terminal studs against the washers 28 and these spacer sleeves are engaged by adjusting nuts 30 threaded on the terminal studs or bolts 17.

By tightening the nuts 30 it can be seen that the plugs 26 can be compressed longitudinally and thus bring about the expansion thereof circumferentially. The expansion of the plugs permits the tight sealing thereof with the inner surface of the tube 10.

The heating element 14 is protected by a novel insulator 31 preferably formed of refractory material. This insulator 31 includes a plurality of independent sections 32 all of the same shape and design. Each section is provided with an axial bore 33 which receives the heating element 14. One face of each section is concaved, as at 34, and the opposite face is of a convex shape, as at 35, and one face of one section fits within the adjacent face of an adjoining section. The ends of the insulator 31 fit against and engage the terminal studs or bolts 17.

In assembly, one end of an electric heating element 14 is secured to its terminal stud or bolt 17 after which the sections of the insulator 31 are threaded over the heating element and the heating element with the insulator and with the plugs are slipped into the tube 10 through one end thereof. After these parts are correctly placed within the tube, then the nuts 30 are tightened.

It can be seen that the heating element is confined within an air tight chamber and hence the creeping of moisture into the tube is prevented and corrosion is eliminated. As the element is sealed within the tube the same operates in a non-oxidizing atmosphere.

It can be seen also that the construction is such that the heating element can be quickly removed from the tube and replaced when so desired.

By stretching the ends 15 and 16 of the heating element 14 temperature is reduced at the terminal posts or bolts 17.

It is to be noted that the nut 21 and the bolt 20 not only function to draw the jaws 19 of the terminal studs or bolts 17 into gripping contact with the ends of the heating element, but also as stops for the washer 27 and the expansion plug 26.

In FIGURES 5 to 8, inclusive, I have shown a modified form of terminal support for the heating element.

In this form, the heating element, now indicated by the reference character 36, does not have the ends thereof stretched, and consequently, the heating element 36 is a continuous coil from one end to the other. The heating element is confined and protected by an insulator 37 of the same type and character as the insulator 32 and the insulator 37 and heating element 36 is confined within the protector tube 38. This tube is in turn rigidly secured to a desired support, such as a wall 39 of a water tank.

Extending axially within the tube 38 and into the bore of the insulator 37 is a terminal stud or bolt 40. This terminal stud or bolt includes a cylindrical body portion 41 and a pointed threaded shank 42. This shank is in the nature of a screw and its diameter is such that the same can be threaded into an end of the heating element 36. The threads of the shank are so formed as to receive and hold the coils of the heating element. The body portion 41 and the shank 42 are separated by an annular enlargement or head 43, which constitutes a stop for an insulating washer 44 and an expanding resilient plug 45. The plug 45 and the washer 44 are provided with bores and are slipped on the body portion 41. The

outer end of the body portion is provided with threads 46 and this threaded end protrudes beyond the tube 38. The extreme end of the threaded portion of the body is preferably flattened on at least one side, as at 47, for a purpose which will later appear. The body portion 41 also has slipped thereon an insulating washer 48 of the same type and character as the washer 44 and hence the expansion plug 45 is confined between the washer 44 and the washer 48. In this form of my invention, I employ an insulating plate or washer 49 of a greater diameter than the washer 48 and this washer 49 engages the outer surface of the wall 39 and the outer edge of the tube 38. An adjusting nut 50 is threaded on the body portion 41 against the washer 49 and by tightening the nut 50 the terminal stud or bolt can be drawn outwardly to compress the plug 45 longitudinally and thus bring about the radial expansion thereof so that the plug will tightly engage the inner surface of the tube 38 and hold the assembly sealed within the tube. A lead in wire 51 is placed on the bolt and the flattened surface 47 tends to prevent the turning thereof and this lead in wire is held in intimate contact with the nut 50 by means of a second nut 52 threaded on said terminal stud or bolt 40.

In this form, it can be seen that I have provided means for permitting the quick association of the heating element 36 with the terminal stud or bolt.

Various changes in details may be made without departing from the spirit or the scope of this invention, but what I claim as new is:

1. In a tank for heating liquids having side walls provided with aligned openings and an electrical heating element for the liquid of the immersion type including, a heat conducting tube having its opposite ends open and disposed within said openings in liquid tight engagement therewith, the outer ends of said tubes being flush with the outer surface of said walls, an electric heating element within said tube, means for sealing the element within said tube including end terminal studs having their inner ends extending into the tube and their outer ends disposed externally of the tube, means securing the ends of the element to the inner ends of the terminal studs, expansion plugs fitted on said studs, means for limiting inward movement of the plugs on the studs, means on the outer ends of the studs for contracting the plugs longitudinally and for expanding the plugs radially into intimate sealing contact with the inner surface of the tube, an insulator disposed within said tube and extending from one terminal stud to the other having an axial bore receiving said heating element, said insulator engaging the inner surface of the tube and including a plurality of like mating sections with each of said sections including a concave face and a convex face, and means for electrically connecting lead wires to the outer ends of the studs.

2. In an electric heating device, a heat conducting tube, a coiled electric heating element disposed axially within the tube, a terminal stud extending into said tube and having a body portion and a pointed threaded shank, said shank being adapted to be threaded into the coils of the element for supporting the element, a stop head formed on the stud between the body portion and shank, an expansion plug on the body portion disposed within the tube and limited in its inward movement by said head, an insulator disposed within said tube and extending from one terminal stud to the other having an axial bore receiving said heating element, said insulator engaging the inner surface of the tube and including a plurality of like mating sections with each of said sections including a concave face and a convex face, a washer on the outer end of said stud for the expansion plug, and a nut threaded on said stud and against said washer for contracting the plug longitudinally and expanding the plug radially into intimate sealing contact with the tube upon adjustment of said nut.

References Cited in the file of this patent

UNITED STATES PATENTS		
885,769	Low et al. -----	Apr. 28, 1908
1,103,171	Bower -----	July 14, 1914
1,367,341	Abbott -----	Feb. 1, 1921
1,480,922	Weydell -----	Jan. 15, 1924
1,736,451	MacInnes -----	Nov. 19, 1929
1,999,037	Dodd -----	Apr. 23, 1935

5

2,489,998
2,624,829
2,672,546
2,780,704

631,407
867,185

Charbonneau et al. ----- Nov. 29, 1949
Dzaack ----- Jan. 6, 1953
Klingner et al. ----- Mar. 16, 1954
Charbonneau ----- Feb. 5, 1957

FOREIGN PATENTS

Germany ----- June 19, 1936
France ----- Apr. 30, 1941