

C. E. ONGLEY.  
ELECTRICALLY CONTROLLED WHISTLE AND VALVE FOR OPERATING SAME.  
No. 522,694. Patented July 10, 1894.

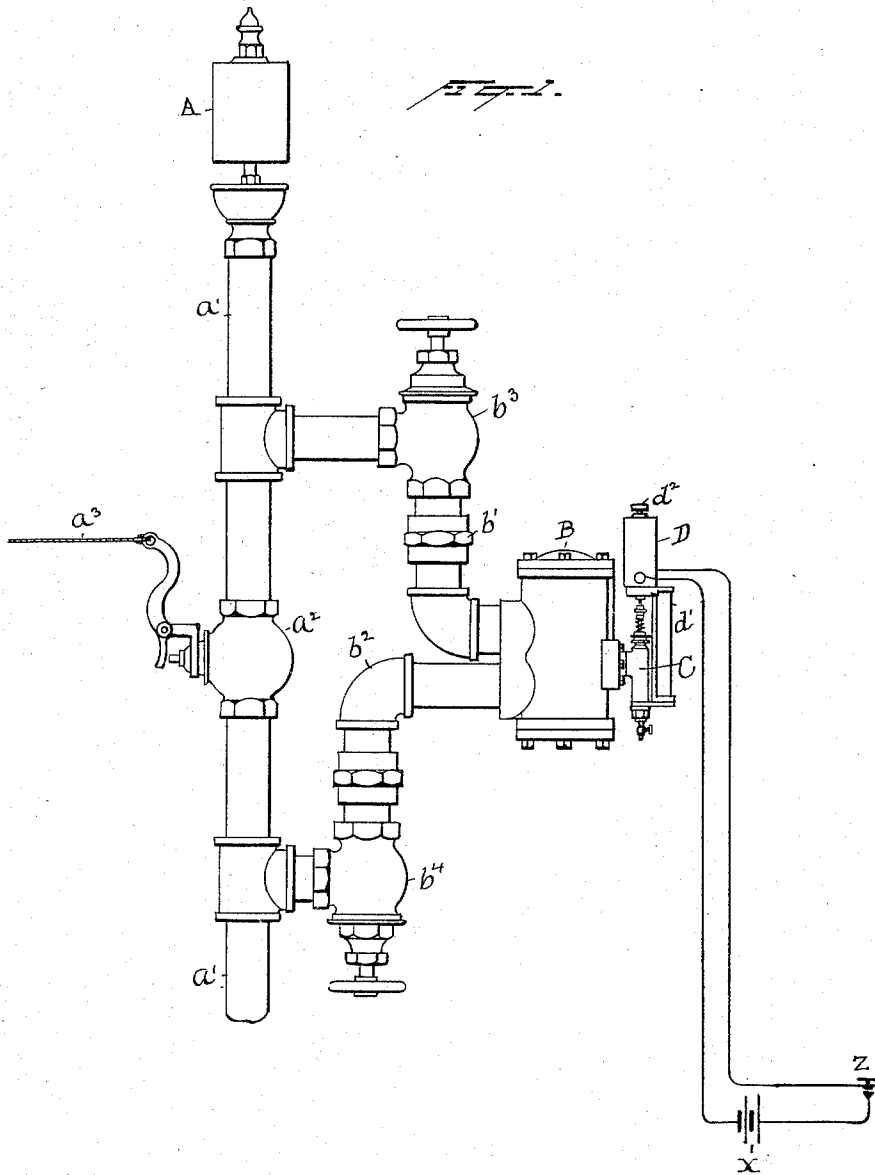

Witnesses  
Norris A. Clark.  
Geot. B. Crouk.

Charles E. Ongley Inventor  
By his Attorneys Ogden & Selig

C. E. ONGLEY.

ELECTRICALLY CONTROLLED WHISTLE AND VALVE FOR OPERATING SAME.

No. 522,694.

Patented July 10, 1894.

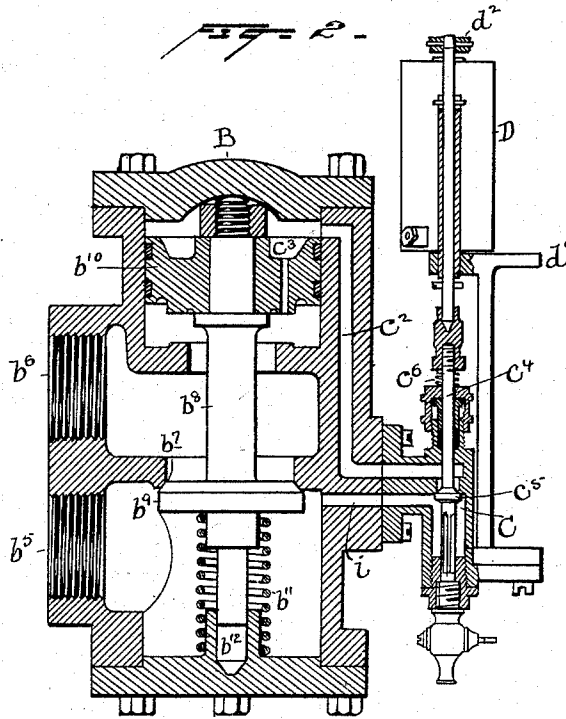

Witnesses  
 Norris A. Clark,  
 Geo. B. Crout.

Charles E. Ongley, Inventor  
 By his Attorneys Ogden & Ogden

# UNITED STATES PATENT OFFICE.

CHARLES E. ONGLEY, OF NEW YORK, N. Y., ASSIGNOR TO GEORGE J. SCHOEFFEL, OF SAME PLACE.

ELECTRICALLY-CONTROLLED WHISTLE AND VALVE FOR OPERATING SAME.

SPECIFICATION forming part of Letters Patent No. 522,694, dated July 10, 1894.

Application filed October 30, 1893. Serial No. 489,507. (No model.)

## To all whom it may concern:

Be it known that I, CHARLES E. ONGLEY, a citizen of the United States, residing at New York city, in the county and State of New York, have invented a certain new and useful Improvement in Electrically-Controlled Whistles and Valves for Operating the Same, of which the following is a specification.

My invention relates to apparatus in which the operation of a whistle is performed or controlled electrically without interfering with means to control said whistle otherwise than electrically and to the construction of a valve especially adapted for this purpose.

In the drawings like letters refer to like parts.

Figure 1 is a view in elevation of apparatus embodying my invention, and Fig. 2 is a sectional view of the valve, and its operating parts.

A is a whistle and  $a'$  and  $a'$  is a pipe to supply pressure to the whistle to operate the same, such as steam or air,  $a^2$  is a valve in said supply pipe moved by the cord  $a^3$  to operate the whistle by hand when necessary, said valve being normally in a closed position.

B is a valve chest connected with the supply pipe  $a'$  and  $a'$  above and below the valve  $a^2$  by the pipes  $b'$  and  $b^2$ . These pipes are preferably provided with valves  $b^3$  and  $b^4$ , which are open during the operation. The pipe  $b^2$  delivers its supply to the valve chest B through the port  $b^5$  and the exit for the same to the whistle is through port  $b^6$  and pipe  $b'$ . Between these ports is the valve seat  $b^7$ . The valve stem  $b^8$  is provided with a valve head  $b^9$ , to rest in the valve seat  $b^7$  and with a piston  $b^{10}$  working in the valve chest B. The valve is normally held seated by the tension of the spring  $b^{11}$ . The valve stem  $b^8$  plays in the sleeve  $b^{12}$  to steady the same. An auxiliary valve C is annexed to the valve chest B, and is constructed in the usual form of a valve, with the valve stem  $c^4$  having a head  $c^5$  and a seat for said head, and a spring  $c^6$  normally holding the same closed. A channel  $c^7$  leads from the valve chest B below the head  $b^9$  into the valve chest of the valve C below the valve, and a channel leads from above the valve C into the valve chest B

above the piston  $b^{10}$ ; this piston  $b^{10}$  is provided with a channel  $c^3$  passing through the same.

D is an electromagnet suitably mounted on the bracket  $d'$ , having an armature  $d^2$  secured to the valve stem  $c^4$ . The said magnet is suitably connected with a battery or other electric generator X and the current is controlled by any suitable form of controlling device. I have shown an ordinary Morse key Z for this purpose.

The operation of my device is as follows: The pressure lying within the valve chest B and below the head  $b^9$  and below the valve C, and it being desired to operate the whistle electrically, I make the circuit to the magnet D. This operates to draw down the armature  $d^2$  to the magnet and to open the valve C, thus admitting pressure into the valve chest B above the piston  $b^{10}$  which moves the valve head  $b^9$  to open the valve and admit the pressure to the whistle A through the port  $b^5$  and pipe  $b'$ . The circuit being again broken the valve C is closed and the valve stem  $b^8$  is subjected to the tension of the spring  $b^{11}$ . Opposed to this tension is the pressure still remaining above the piston  $b^{10}$ . This pressure escapes through the channel  $c^3$ . It will be noted that the channels  $c^7$ , valve C and channel  $c^2$  are of greater size than channel  $c^3$ , thus allowing the pressure introduced to operate the valve, notwithstanding a certain amount of leakage through the channel  $c^3$  and yet the channel  $c^3$  being of sufficient size to admit of the escape of the pressure under the tension of the spring  $b^{11}$ .

It will be noted that by my arrangement I do not interfere with the valve usually employed to control the whistle otherwise than electrically, but I provide a by-pass in which the valve that I control electrically is located, thus enabling me to adapt my device to existing conditions, without interfering with the same, as the valve  $a^2$  may be operated at will by the cord  $a^3$ .

By my apparatus it will be readily seen that, in addition to the ordinary use of the whistle, I can operate it by a key to signal according to a code of signals with accuracy and precision.

What I claim is—

1. The combination with a whistle, of a

hand-operated valve for controlling the supply of pressure thereto, a by-pass around said valve, a valve in said by-pass, an electro-magnet for operating said last-named valve, and means for controlling the flow of current to said magnet, whereby said whistle can be operated either by the hand-operated valve or by the electric valve, substantially as and for the purpose set forth.

2. The combination with a whistle, of a valve for controlling the supply of pressure thereto, a by-pass around said valve, a valve located in said by-pass, consisting of a valve-chest having ports, a valve stem having a valve-head and a piston thereon, a spring normally holding the valve-head seated, an auxiliary valve for controlling the valve in said by-pass and operated electrically, whereby said whistle can be operated by

either the valve in the by-pass or the first-named valve, substantially as and for the purpose set forth.

3. In a valve, the combination of a valve chest, having ports and valve seat, a valve stem having two heads one to fit the seat and the other the chest, and a spring normally holding the valve head seated, and means controlled electrically to admit pressure into the valve chest and between the head of the valve chest and the valve stem head, and means to allow the escape of the pressure thus admitted, substantially as described.

This specification signed and witnessed this 25th day of October, 1893.

CHARLES E. ONGLEY.

Witnesses:

V. BLOOM,

GEO. J. SCHOEFFEL.