

(19) World Intellectual Property Organization
International Bureau



(43) International Publication Date
4 March 2004 (04.03.2004)

PCT

(10) International Publication Number
WO 2004/019059 A1

(51) International Patent Classification⁷: **G01T 1/20**

PHILIPS ELECTRONICS N.V. [NL/NL]; Groenewoudseweg 1, NL-5621 BA Eindhoven (NL).

(21) International Application Number:
PCT/IB2003/003614

(72) Inventors; and

(22) International Filing Date: 14 August 2003 (14.08.2003)

(75) Inventors/Applicants (for US only): **JUESTEL, Thomas** [DE/DE]; c/o Philips Intellectual Property & Standards GmbH, Weissshausstr. 2, 52066 Aachen (DE). **MAYR, Walter** [DE/DE]; c/o Philips Intellectual Property & Standards GmbH, Weissshausstr. 2, 52066 Aachen (DE). **WIECZOREK, Herfried, Karl** [DE/DE]; c/o Philips Intellectual Property & Standards GmbH, Weissshausstr. 2, 52066 Aachen (DE).

(25) Filing Language: English

(26) Publication Language: English

(30) Priority Data:
102 38 398.7 22 August 2002 (22.08.2002) DE

(71) Applicant (for DE only): **PHILIPS INTELLECTUAL PROPERTY & STANDARDS GMBH** [DE/DE]; Stein-damm 94, 20099 Hamburg (DE).

(74) Agent: **VOLMER, Georg**; Philips Intellectual Property & Standards GmbH, Weissshausstr. 2, 52066 Aachen (DE).

(71) Applicant (for AE, AG, AL, AM, AT, AU, AZ, BA, BB, BE, BG, BR, BY, BZ, CA, CH, CN, CO, CR, CU, CY, CZ, DK, DM, DZ, EC, EE, ES, FI, FR, GB, GD, GE, GH, GM, GR, HR, HU, ID, IE, IL, IN, IS, JP, KE, KG, KP, KR, KZ, LC, LK, LR, LS, LT, LU, LV, MA, MD, MG, MK, MN, MW, MX, MZ, NI, NO, NZ, OM, PG, PH, PL, PT, RO, RU, SC, SD, SE, SG, SK, SL, SY, SZ, TJ, TM, TN, TR, TT, TZ, UA, UG, UZ, VC, VN, YU, ZA, ZM, ZW only): **KONINKLIJKE**

(81) Designated States (national): AE, AG, AL, AM, AT, AU, AZ, BA, BB, BG, BR, BY, BZ, CA, CH, CN, CO, CR, CU, CZ, DE, DK, DM, DZ, EC, EE, ES, FI, GB, GD, GE, GH, GM, HR, HU, ID, IL, IN, IS, JP, KE, KG, KP, KR, KZ, LC, LK, LR, LS, LT, LU, LV, MA, MD, MG, MK, MN, MW, MX, MZ, NI, NO, NZ, OM, PG, PH, PL, PT, RO, RU, SC, SD, SE, SG, SK, SL, SY, TJ, TM, TN, TR, TT, TZ, UA, UG, US, UZ, VC, VN, YU, ZA, ZM, ZW.

[Continued on next page]

(54) Title: DEVICE FOR GENERATING IMAGES AND/OR PROJECTIONS

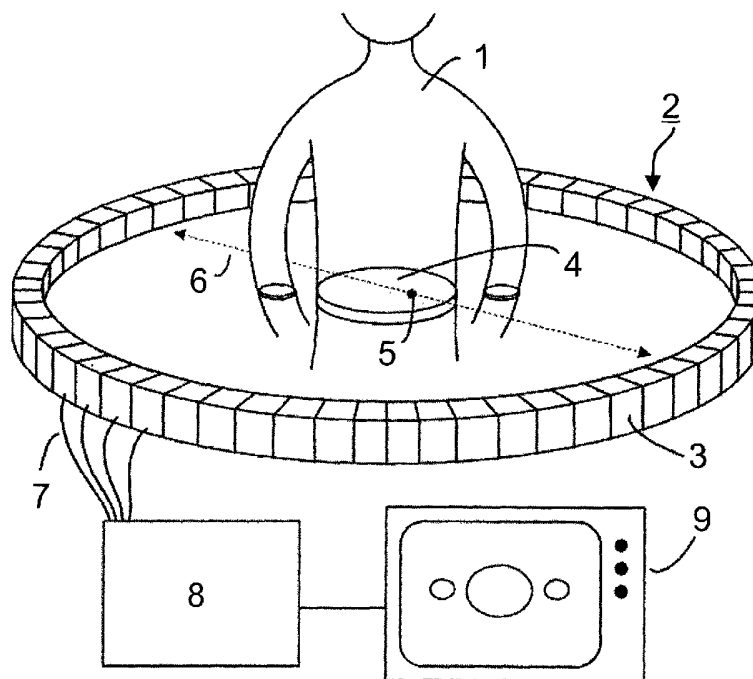

(57) Abstract: The invention relates to a device for generating images and/or projections, which device includes a device for the detection of input radiation. The device for the detection of input radiation comprises a sensor with a Pr³⁺-activated scintillator for converting the input radiation into UV radiation. The Pr³⁺-activated scintillators have short excitation and decay times.

WO 2004/019059 A1



(84) Designated States (regional): ARIPO patent (GH, GM, KE, LS, MW, MZ, SD, SL, SZ, TZ, UG, ZM, ZW), Eurasian patent (AM, AZ, BY, KG, KZ, MD, RU, TJ, TM), European patent (AT, BE, BG, CH, CY, CZ, DE, DK, EE, ES, FI, FR, GB, GR, HU, IE, IT, LU, MC, NL, PT, RO, SE, SI, SK, TR), OAPI patent (BF, BJ, CF, CG, CI, CM, GA, GN, GQ, GW, ML, MR, NE, SN, TD, TG).

Published:

— with international search report

For two-letter codes and other abbreviations, refer to the "Guidance Notes on Codes and Abbreviations" appearing at the beginning of each regular issue of the PCT Gazette.

Device for generating images and/or projections

The invention relates to a device for generating images and/or projections by means of an imaging method, which device includes a device for the detection of input radiation which includes at least one acquisition element which comprises a sensor for converting the input radiation and a photodiode which converts an optical signal into an electrical signal. The invention also relates to a device for the detection of input radiation.

Tomography is a slice imaging method used in the field of medical X-ray diagnosis. According to this method a coupled motion of the tube and the film takes place in opposite directions while the patient remains stationary. A given, selected depth zone is thus sharply imaged on the film, whereas parts of the objects which are situated higher or deeper are blurred because of the continuously changing projection.

In X-ray tomography the attenuation of X-rays by a given slice of the body of the patient is measured by means of a plurality of detectors in different projection directions. To this end, a narrow X-ray beam (fan beam) is formed by means of an X-ray tube and diaphragms. This beam traverses the relevant part of the body and is attenuated to a different degree by the various structures within the body (for example, the skin, fat, muscles, organs, bones).

Exactly opposite the X-ray tube there is arranged a plurality of detectors which receive the attenuated signal and process it electronically so as to propagate it to a computer for evaluation. Subsequently, the X-ray tube and the oppositely situated detectors are rotated slightly further around the patient.

The described procedure is then repeated. Various views (projections) of the same slice are thus generated and converted into a grey scale image in the computer. This image can be viewed and evaluated on a display screen or an X-ray film. This technique yields images which contain significantly more contrast than those produced by a conventional X-ray technique.

A further method based on the principle of tomography is called Emission Computer Tomography (ECT) which is based on the measurement in slices of temporarily incorporated radionuclides (scintigraphy). The emission of positrons from ^{15}O carbon dioxide or ^{68}Ge (Positron Emission Computer Tomography or PET) or photons from $^{99\text{m}}\text{Tc}$ or ^{123}I

(Single Photon Emission Computer Tomography or SPECT) is then measured. Such nuclear medical tomography methods offer the advantage that they present the viewer of the tomographically generated image with information which goes beyond pure morphology and which possibly also images physiological events.

5 In contemporary computer tomography two basic types of radiation detectors can be distinguished: direct converters (for example, xenon gas detectors) and scintillation detectors. In the case of solid-state detectors, made of a scintillation material (scintillator), the visible light emitted after excitation is collected by photodiodes. In X-ray computer tomography solid-state detectors contain either cadmium tungstate (CdWO_4) or materials on
10 the basis of rare earths. Frequently used scintillators are Ce^{3+} -doped materials such as, for example, $\text{Lu}_2\text{SiO}_5:\text{Ce}$ or $\text{Gd}_2\text{SiO}_5:\text{Ce}$. In PET methods or in SPECT methods the scintillator often used is NaI:Tl or bismuth germanate $\text{Bi}_4\text{Ge}_3\text{O}_{12}$ (BGO). Detectors provided with a scintillator in the form of Ce^{3+} -doped materials are known, for example, from EP 1 004 899.

The scintillator must satisfy some conditions. For example, the scintillator
15 must have a high density, a high luminous efficiency and a short excitation and decay time.

The decay time τ of NaI:Tl amounts to 250 ns, that of BGO to 300 ns, that of $\text{Lu}_2\text{SiO}_5:\text{Ce}$ to 40 ns and that of $\text{Gd}_2\text{SiO}_5:\text{Ce}$ to 56 ns. For many applications it is desirable to utilize scintillators having even shorter decay times.

Therefore, it is an object of the invention to provide a device for tomography
20 which comprises a scintillator having a shorter decay time τ .

This object is achieved by means of a device for generating images and/or projections by means of an imaging method, which device includes a device for the detection of input radiation which includes at least one acquisition element which comprises a sensor with a Pr^{3+} -activated scintillator for converting the input radiation into UV radiation and a
25 photodiode which converts an optical signal into an electrical signal.

Pr^{3+} -activated scintillators have short decay times τ in the range below 25 ns which, therefore, are even shorter than those of Ce^{3+} -activated scintillators.

Because of the short decay time τ , the integration time can be reduced during the determination of the intensity of the input radiation, so that the image rate for the
30 generating of images and/or projections can be significantly increased. Because of the increased image rate, the occurrence of artifacts, for example, shadow images, is reduced. Furthermore, the examination time is reduced for the patient, because more single images can be measured within a shorter period of time.

The advantageously selected Pr³⁺-activated scintillators in conformity with claim 2 have short excitation times and short decay times τ . Furthermore, they emit UV radiation in response to excitation by means of X-rays or γ quanta.

For the advantageously chosen imaging methods in conformity with the claims 3 to 5 it is important that the scintillator has a short decay time and hence enables a high image rate. The time window is of major importance notably for the PET method and it is particularly advantageous to utilize a scintillator having a short decay time in the device for determining input radiation.

The advantageous embodiments in conformity with the claims 6 to 8 make it possible to use a larger part of the input radiation for the image analysis. The luminous substance that can be excited by ultraviolet radiation absorbs the ultraviolet radiation emitted by the scintillator and converts it into long-wave radiation adapted to the spectral sensitivity of the photodiode. As a result, overlapping of the emission spectrum of the scintillator and the sensitivity spectrum of the photodiode is maximum and the photodiode can operate with a maximum quantum efficiency.

The invention also relates to a device for the detection of input radiation which includes at least one acquisition element which comprises a sensor with a Pr³⁺-activated scintillator for converting the input radiation into ultraviolet radiation and a photodiode which converts an optical signal into an electrical signal.

Embodiments of the invention will be described in detail hereinafter with reference to the accompanying Figures. Therein:

Fig. 1 is a diagrammatic representation of the construction of a device for generating images and/or projections by means of the PET method,

Fig. 2 shows the excitation and emission spectrum of CaLi₂SiO₄:Pr, Na,

Fig. 3 shows the excitation and emission spectrum of LuPO₄:Pr,

Fig. 4 shows the excitation and emission spectrum of Lu₂SiO₅:Pr, and

Fig. 5 shows the excitation and emission spectrum of LaPO₄:Pr.

A device for generating images and/or projections can operate with various imaging methods. Preferably, the device is arranged to carry out the PET method or the SPECT method as the imaging method, or to carry out the imaging method by means of X-rays.

In conformity with the PET method, a metabolic preparation marked with given, unstable nuclides is injected into a patient; this preparation is taken up in a tissue-specific or function-specific manner. The radionuclides used decay, giving rise to two γ

quanta in different successive processes in the vicinity of the location of decay; these two quanta fly in exactly opposite directions and leave the patient so as to be detected by the sensors which are arranged in the form of a ring around the patient in the device for the detection of input radiation. During their travel from the location of origin to the location
5 where they emerge from the patient the γ quanta traverse further tissue of the patient; this tissue can absorb the γ quanta more or less in dependence on the type of tissue. Generally speaking, the γ quanta are attenuated in a tissue-specific manner. All detected γ quanta together form a set of projections of the image wherefrom a slice image or volume image is reconstructed in known manner during a subsequent reconstruction operation. The PET
10 method yields functional images of the object.

The two γ quanta have the same energy of 511 keV. The detection of the γ quanta is performed by means of scintillators in the sensor of the device for the detection of input radiation.

Fig. 1 is a diagrammatic representation of a device for forming a slice image
15 by means of the PET method. The patient, or the object to be examined 1, is arranged within a ring-like device 2 for the detection of input radiation which consists of individual detection or acquisition elements 3. The plane defined by the ring intersects the object 1, for example, in the plane of intersection 4. The described decay process takes place at the location 5 where
20 two γ quanta leave the object 1 in opposite directions along the double arrow 6. The individual sensor elements 3 of the device 2 for the detection of input radiation are connected, via leads 7, to a data processing unit 8 which evaluates the signals from the detection elements 3. The slice image formed is subsequently displayed on a display device
8.

A high temporal resolution is very important for the PET method, because the
25 entire process from the emission of the positron until the detection of the γ quanta takes place within a few nanoseconds. Because of the short decay time τ , the integration time during the determination of the intensity of the input radiation can be reduced, so that the image rate can be significantly increased. As a result of the increased image rate, a higher dose of nuclides can be administered to the patient so as to reduce the overall examination time.

30 Furthermore, for the PET method it is also important to determine the energy of the γ quanta in order to ensure that they have not left their original trajectory due to scattering processes. Such γ quanta have an energy value which is lower than 511 keV. The energy value of the γ quanta is determined from the level of the detected signal. In this

respect it is important that the scintillator is in the normal state again and not in an excited state still, as otherwise an energy value of 511 keV will be unduly determined, despite the fact that the γ quantum was scattered and has a lower energy value.

The SPECT method also is a nuclear medical examination method. The
5 nuclides used for the SPECT method originate from natural decay and emitted γ quanta with energies of 141 keV (^{99m}Tc) at 159 keV (^{123}I). Like in the PET method, the emitted γ quanta are detected by the device for the detection of input radiation and their signal is amplified. However, a collimator is arranged in front of each detection element. The collimator serves as an objective and consists of a lead plate which is provided with bores which are arranged
10 in parallel or in a converging fashion. γ quanta which are incident at an angle are absorbed by the collimator, thus enabling the three-dimensional imaging.

In the case of X-ray computer tomography the device for generating images or projections includes an X-ray tube which emits a fine, usually fan-shaped beam and moves in a circle around the longitudinal axis of the object to be examined. After having traversed the
15 object, the X-rays transmitted by the tissue of the object are captured again by an oppositely situated device for the detection of input radiation. For small fields of a format of approximately 1.5x1.5 mm the computer calculates the difference between the emitted energy and the received intensity of the X-ray beam and forms from the different values a grey scale image which is displayed on a display device. The grey values correspond to the
20 respective relative density of the tissue.

Like in the PET method, according to the latter two methods the integration time during the detection of the intensity of the input radiation can again be reduced as a result of the short decay time τ , so that the image rate for the generating of images and/or projections can be significantly increased. As a result of the increased image rate, the
25 occurrence of artifacts, such as shadow images, is reduced and also the period of time required to carry out the imaging method.

The device for the detection of input radiation may be composed of a plurality of acquisition elements, each acquisition element comprising a sensor for converting the input radiation into UV radiation and a photodiode. It is particularly advantageous when each
30 acquisition element comprises an array of photodiodes. The sensor and the photodiode array are customarily formed as a respective layer and combined so as to form a system of layers.

The sensor layer constitutes the entrance screen for the input radiation which is preferably formed by X-rays or γ rays. Underneath the sensor layer there is arranged the

layer with the photodiodes. Electrical contact leads extend from the layer with the photodiodes to the electronic read-out circuitry.

The essential element of the sensor is formed by a layer of a Pr^{3+} -activated scintillator which converts the input radiation into UV radiation. It is very advantageous when the sensor comprises a layer of $\text{LaPO}_4:\text{Pr}$, $\text{LuF}_3:\text{Pr}$, $\text{LuCl}_3:\text{Pr}$, $\text{LuBr}_3:\text{Pr}$, $(\text{Lu}_{1-x}\text{Y}_x)\text{PO}_4:\text{Pr}$, where $0 \leq x \leq 1$, $(\text{Lu}_{1-x}\text{Y}_x)\text{SiO}_5:\text{Pr}$, where $0 \leq x \leq 1$, $(\text{Lu}_{1-x}\text{Y}_x)\text{Si}_2\text{O}_7:\text{Pr}$, where $0 \leq x \leq 1$, $(\text{Lu}_{1-x}\text{Y}_x)\text{BO}_3:\text{Pr}$, where $0 \leq x \leq 1$, or $\text{Ca}_{1-2y}\text{Li}_2\text{SiO}_4:\text{Pr}_y\text{Na}_y$, where $0.001 \leq y \leq 0.2$. Such Pr^{3+} -activated materials emit UV radiation after excitation and have short decay times.

Table 1: Emission bands and decay times of selected Pr^{3+} -activated and Ce^{3+} -activated scintillators.

| Scintillator | Emission wavelength λ_{max} [nm] | Decay time τ [ns] |
|-------------------------------------|-------------------------------------------------|------------------------|
| $\text{LuPO}_4:\text{Pr}$ | 235 | 9 |
| $\text{Lu}_2\text{SiO}_5:\text{Pr}$ | 270 | 16 |
| $\text{LuPO}_4:\text{Ce}$ | 350 | 24 |
| $\text{Lu}_2\text{SiO}_5:\text{Ce}$ | 420 | 40 |

The shorter decay time τ of the Pr^{3+} -activated scintillators, that is, in comparison with the corresponding Ce^{3+} -activated scintillators, can be derived from the ratio $\tau \approx 1/\lambda_{\text{max}}^2$. The 5d levels of the free Pr^{3+} cation are situated approximately 62000 cm^{-1} above the 4f levels, whereas this energy difference amounts to only 50000 cm^{-1} in the free Ce^{3+} cation. This larger energy difference is also responsible for the fact that the emission bands of Pr^{3+} -activated scintillators, originating from 5d-4f transitions, are of higher energy than the emission bands of corresponding Ce^{3+} -activated scintillators. Therefore, their main emission bands of the Pr^{3+} -activated scintillators in accordance with the invention are situated in the range from 220 to 350 nm, so in the range of UV radiation, whereas the emission bands of Ce^{3+} -activated scintillators are of a significantly longer wavelength.

The sensor layer with the Pr^{3+} -activated scintillator is customarily formed by pressing. A powder of the appropriate Pr^{3+} -activated scintillator is formed first; this powder is subsequently converted into a crystal layer by means of a pressing method, for example, high-pressure cold pressing or high-temperature isostatic pressing. The size of such pressed

crystals is in the range of from a few millimeters to a few centimeters. A sensor layer of this kind is bonded to the layer with the photodiodes.

The powdery scintillator material can be formed from the starting compounds by a solid-state reaction as well as by reactions in an aqueous or aqueous-alcoholic solution.

5 During the latter reaction the relevant metal salts and/or metal oxides are possibly dissolved or suspended with a combination of the anion of the scintillator in water or a water-alcohol mixture so as to be reacted.

In the photodiodes the UV radiation is converted into electrical signals.

10 Because of the emission in the range of UV radiation, only UV-sensitive photodiodes can be used in the device for the detection of input radiation. For example, photodiodes with Cs₃Sb photocathodes, bialkaline photocathodes or multialkaline photocathodes can be used. Furthermore, use can also be made of photodiodes based on Si, GaN or AlGaN.

15 In order to enlarge the choice of suitable photodiodes, a color converter which converts UV radiation into radiation of longer wavelength can be arranged between the sensor layer and the layer with the photodiodes. To this end, the color converter contains a luminous substance which can be excited by UV radiation. The color converter thus converts the UV radiation emitted by the sensor into radiation having a wavelength range which corresponds to the maximum of the spectral sensitivity of the photodiode used. The radiation of longer wavelength may comprise colored light or infrared radiation.

20 For the luminous substances use can notably be made of organic luminous substances with a high photoluminescence quantum efficiency and a short decay time τ . Particularly attractive luminous substances are Coumarins such as Coumarin 1 ($\lambda_{\max} = 430 \text{ nm}$) or Coumarin 120 ($\lambda_{\max} = 442 \text{ nm}$) or lumogen dyes such as Lumogen F Violet 570 marketed by BASF. The decay times τ of these luminous substances are less
25 than 10 ns.

The color converter may comprise, for example, a polymer light guide which is doped with the luminous substance. The polymer light guide may contain, for example, polymethylmethacrylate, polystyrol, polytetrafluoroethylene, polycarbonate, polyimide or polyvinylchloride. Alternatively, the color converter may comprise two components, that is,
30 the polymer light guide and a separate layer with the luminous substance. In this embodiment the polymer light guide adjoins the sensor layer of the acquisition element; the separate layer with the luminous substance adjoins the polymer light guide and is adjoined itself by the layer with the photodiodes.

Example 1

For the production of $\text{Ca}_{0.98}\text{Li}_2\text{SiO}_4:\text{Pr}_{0.01},\text{Na}_{0.01}$, 25.0 g (278 mmol) Li_2SiO_3 , 147 mg (1.39 mmol) Na_2CO_3 , 27.3 g (272 mmol) CaCO_3 and 1.21 g (2.78 mmol) $\text{Pr}(\text{NO}_3)_3 \cdot 6\text{H}_2\text{O}$ were mixed in demineralized H_2O and suspended. The water was removed by distillation and the residue obtained was dried. Subsequently, the reaction product was
5 annealed once in air at 700 °C for two hours and annealed twice in a CO atmosphere at 850 °C for each time 12 hours. The scintillator powder was rinsed several times with water and ethanol, dried and ground on a roller device for several hours. The resultant scintillator powder had an average particle size of 3 μm . The excitation and emission spectrum of this scintillator is shown in Fig. 2. The decay time τ of $\text{Ca}_{0.98}\text{Li}_2\text{SiO}_4:\text{Pr}_{0.01},\text{Na}_{0.01}$ amounts to
10 16 ns.

Example 2

40.0 g (101 mmol) Lu_2O_3 and 883 mg (2.03 mmol) $\text{Pr}(\text{NO}_3)_3 \cdot 6\text{H}_2\text{O}$ were suspended in 200 ml ethanol in order to produce $\text{LuPO}_4:\text{Pr}$. 25.8 g (223 mmol) 85% phosphoric acid was added slowly while stirring. The suspension was stirred for twenty-four
15 hours and subsequently concentrated in a rotary evaporator. The residue was dried at 100 °C, mortarized and mixed with 500 mg NH_4Cl . Subsequently, the scintillator powder was calcinated twice for 2 hours at 1250 °C in a CO atmosphere and subsequently mortarized each time again. Finally, the scintillator powder was calcinated once more in air at 1250 °C for 1 hour. The excitation and emission spectrum of this scintillator is shown in Fig. 3. The
20 decay time τ of $\text{LuPO}_4:\text{Pr}$ amounts to 9 ns.

Example 3

10.0 g (25.1 mmol) Lu_2O_3 , 1.51 g (25.1 mmol) and 86.0 mg (84.1 μmol) Pr_6O_{11} were suspended in 200 ml ethanol in order to produce $\text{Lu}_2\text{SiO}_5:\text{Pr}$. The suspension was treated in an ultrasound bath for ten minutes and subsequently concentrated in a rotary
25 evaporator. The residue obtained was dried at 100 °C, mortarized and mixed with 500 mg CsF . Subsequently, calcination took place in a CO atmosphere for 6 hours at 1350 °C and the scintillator powder obtained was subsequently mortarized. Finally, the scintillator powder was rinsed in 500 ml water for two hours, sucked off and dried at 100 °C. The excitation and emission spectrum of this scintillator is shown in Fig. 5. The decay time τ of
30 $\text{Lu}_2\text{SiO}_5:\text{Pr}$ amounts to 16 ns.

Example 4

91.4 g (282 mmol) La_2O_3 and 883 mg (2.48 mmol) $\text{PrCl}_3 \cdot 6\text{H}_2\text{O}$ were suspended in 200 ml water in order to manufacture $\text{LaPO}_4:\text{Pr}$. 69.0 g (598 mmol) 85%

phosphoric acid was added slowly while stirring. The suspension was stirred for 24 hours and subsequently concentrated in a rotary evaporator. The residue obtained was dried at 100 °C, mortarized and mixed with 1.2 g LiF. The scintillator was calcinated in a nitrogen atmosphere for 2 hours at 1000 °C. The scintillator powder obtained was rinsed in diluted
5 HNO₃ for 6 hours at 60 °C. Finally, the scintillator was sucked off, rinsed acid free with water and dried at 100 °C. Fig. 6 shows the excitation and emission spectrum of this scintillator. The decay time τ of LaPO₄:Pr amounts to 11 ns.

CLAIMS:

1. A device for generating images and/or projections by means of an imaging method, which device includes a device for the detection of input radiation which includes at least one acquisition element which comprises a sensor with a Pr^{3+} -activated scintillator for converting the input radiation into UV radiation and a photodiode which converts an optical
5 signal into an electrical signal.
2. A device for generating images and/or projections as claimed in claim 1, characterized in that the Pr^{3+} -activated scintillator is chosen from the group $\text{LaPO}_4:\text{Pr}$, $\text{LuF}_3:\text{Pr}$, $\text{LuCl}_3:\text{Pr}$, $\text{LuBr}_3:\text{Pr}$, $(\text{Lu}_{1-x}\text{Y}_x)\text{PO}_4:\text{Pr}$ where $0 \leq x \leq 1$, $(\text{Lu}_{1-x}\text{Y}_x)\text{SiO}_5:\text{Pr}$, where
10 $0 \leq x \leq 1$, $(\text{Lu}_{1-x}\text{Y}_x)\text{Si}_2\text{O}_7:\text{Pr}$, where $0 \leq x \leq 1$, $(\text{Lu}_{1-x}\text{Y}_x)\text{BO}_3:\text{Pr}$, where $0 \leq x \leq 1$, and $\text{Ca}_{1-2y}\text{Li}_2\text{SiO}_4:\text{Pr}_y\text{Na}_y$, where $0.001 \leq y \leq 0.2$.
3. A device for generating images and/or projections as claimed in claim 1 or claim 2, characterized in that the device is arranged to carry out the PET method as the
15 imaging method.
4. A device for generating images and/or projections as claimed in claim 1 or claim 2, characterized in that the device is arranged to carry out the SPECT method as the
20 imaging method.
5. A device for generating images and/or projections as claimed in claim 1 or claim 2, characterized in that the device is arranged to carry out the imaging method by means of X-rays.
- 25 6. A device for generating images and/or projections as claimed in one of the claims 1 to 5, characterized in that a color converter which contains a luminous substance which can be excited by UV radiation is arranged between the sensor and the photodiode in the device for the detection of input radiation.

7. A device for generating images and/or projections as claimed in claim 6, characterized in that the color converter comprises a polymer light guide which is doped with the luminous substance that can be excited by UV radiation.
- 5 8. A device for generating images and/or projections as claimed in claim 6, characterized in that the color converter comprises a polymer light guide and a separate layer with the luminous substance that can be excited by UV radiation.
9. A device for the detection of input radiation which includes at least one
10 acquisition element which comprises a sensor with a Pr^{3+} -activated scintillator for converting the input radiation into UV radiation and a photodiode which converts an optical signal into an electrical signal.

1/3

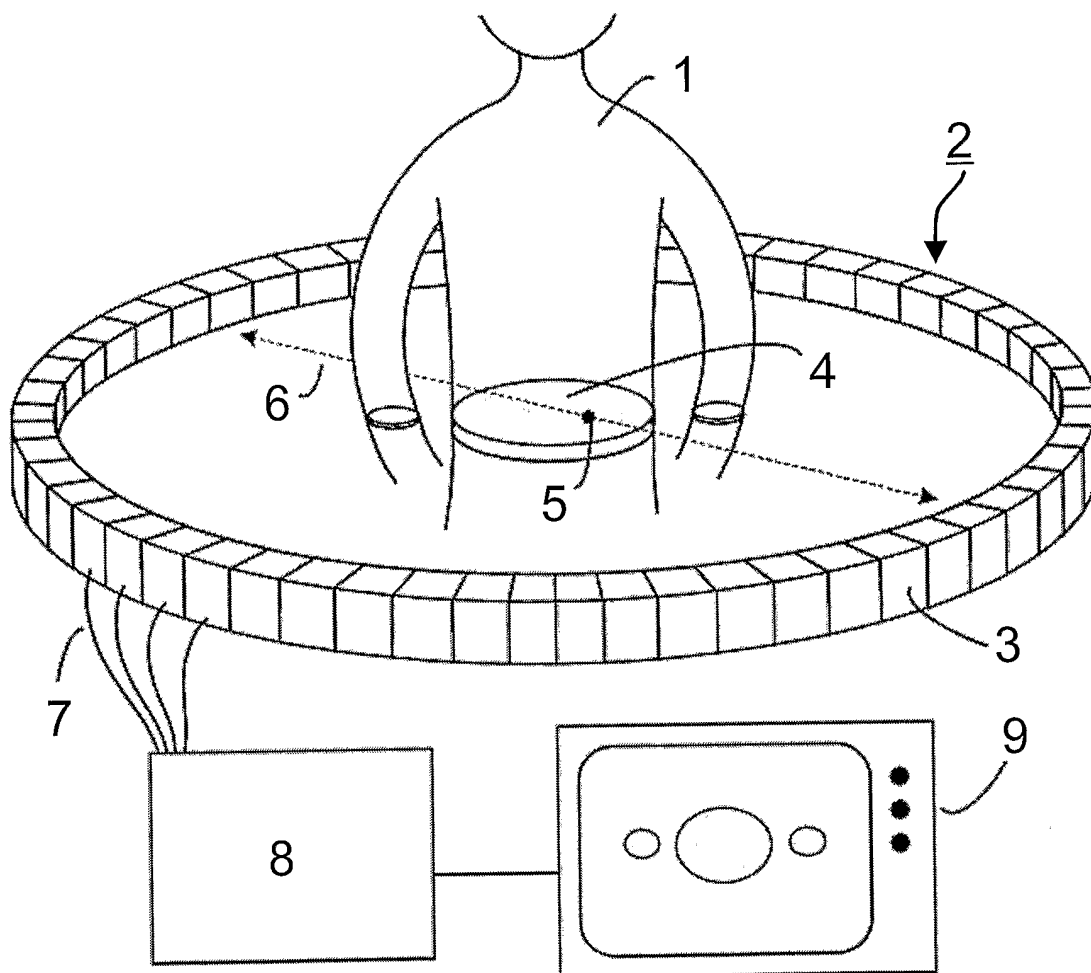

Fig. 1

2/3

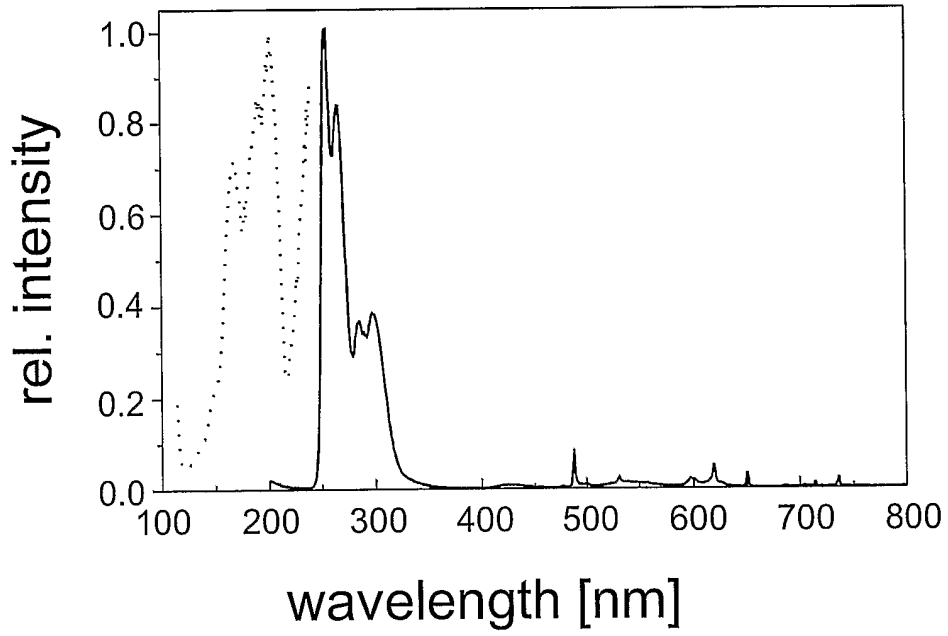

FIG. 2

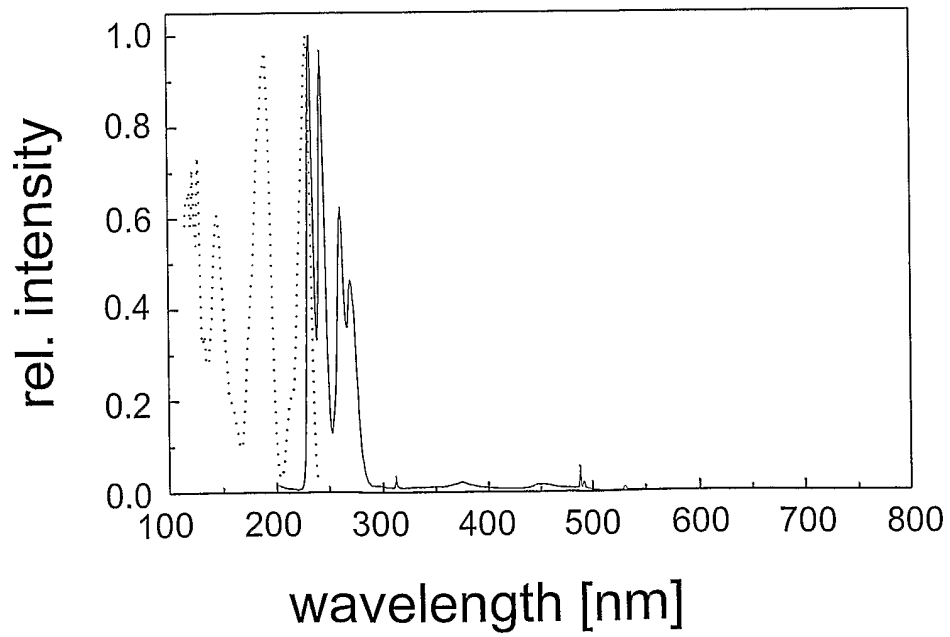

FIG. 3

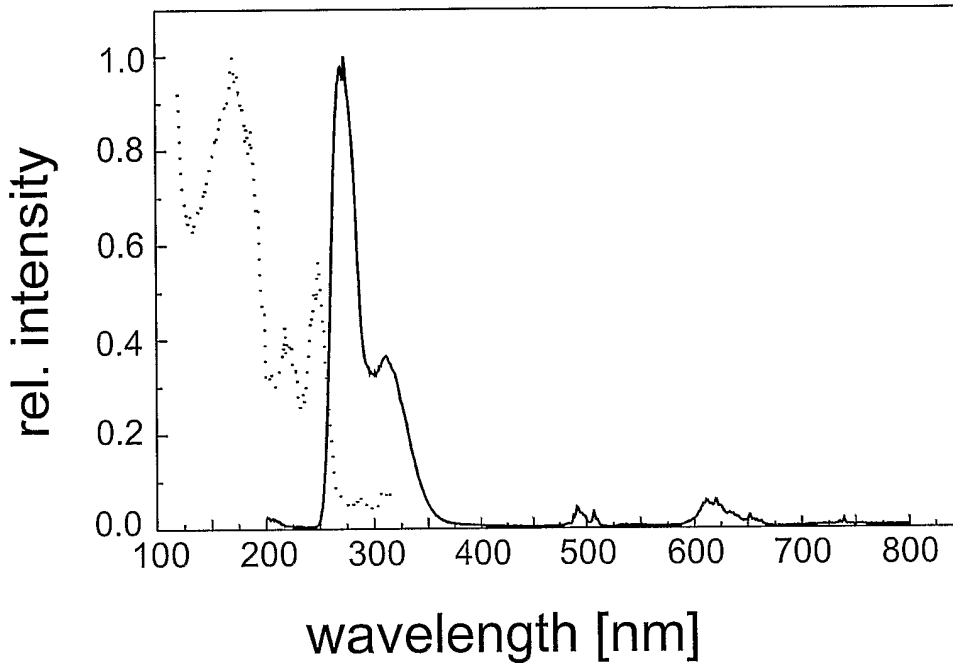

FIG. 4

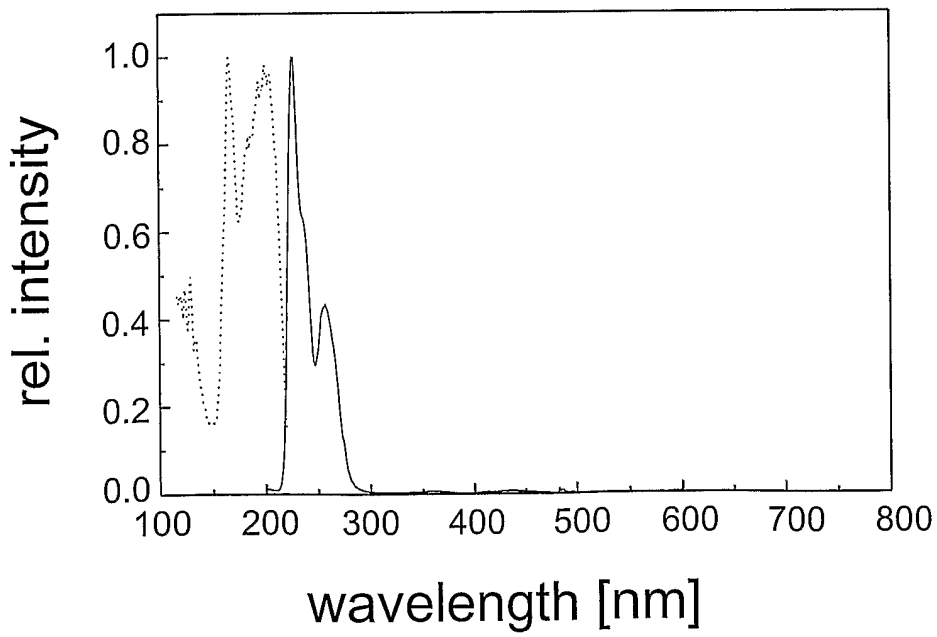

FIG. 5

INTERNATIONAL SEARCH REPORT

Internatic plication No
PCT/IB 03/03614

A. CLASSIFICATION OF SUBJECT MATTER
IPC 7 G01T1/20

According to International Patent Classification (IPC) or to both national classification and IPC

B. FIELDS SEARCHED

Minimum documentation searched (classification system followed by classification symbols)
IPC 7 G01T C09K H01J

Documentation searched other than minimum documentation to the extent that such documents are included in the fields searched

Electronic data base consulted during the international search (name of data base and, where practical, search terms used)

EPO-Internal, WPI Data, PAJ, INSPEC, COMPENDEX

C. DOCUMENTS CONSIDERED TO BE RELEVANT

| Category ° | Citation of document, with indication, where appropriate, of the relevant passages | Relevant to claim No. |
|------------|----------------------------------------------------------------------------------------------------------------------------------------------------------------------------------------------------------------------------------------------------------------------------------------------|-----------------------|
| X | EIJK VAN C W E ET AL: "ND3+ AND PR3+ DOPED INORGANIC SCINTILLATORS" RECORD OF THE NUCLEAR SCIENCE SYMPOSIUM AND MEDICAL IMAGING CONFERENCE SAN FRANCISCO, OCT. 30 - NOV. 6, 1993, NEW YORK, IEEE, US, vol. 1, 30 October 1993 (1993-10-30), pages 664-667, XP000481430 the whole document | 1, 3-5, 9 |
| Y | --- | 2, 6-8 |
| Y | US 2001/006214 A1 (BOERNER HERBERT FRIEDRICH ET AL) 5 July 2001 (2001-07-05) paragraphs '0007!, '0008!, '0016!, '0017!, '0022!, '0028! --- | 6-8 |
| | -/-- | |

Further documents are listed in the continuation of box C.

Patent family members are listed in annex.

° Special categories of cited documents :

- *A* document defining the general state of the art which is not considered to be of particular relevance
- *E* earlier document but published on or after the international filing date
- *L* document which may throw doubts on priority claim(s) or which is cited to establish the publication date of another citation or other special reason (as specified)
- *O* document referring to an oral disclosure, use, exhibition or other means
- *P* document published prior to the international filing date but later than the priority date claimed

- *T* later document published after the international filing date or priority date and not in conflict with the application but cited to understand the principle or theory underlying the invention
- *X* document of particular relevance; the claimed invention cannot be considered novel or cannot be considered to involve an inventive step when the document is taken alone
- *Y* document of particular relevance; the claimed invention cannot be considered to involve an inventive step when the document is combined with one or more other such documents, such combination being obvious to a person skilled in the art.
- *&* document member of the same patent family

Date of the actual completion of the international search

6 November 2003

Date of mailing of the international search report

20/11/2003

Name and mailing address of the ISA

European Patent Office, P.B. 5818 Patentlaan 2
NL - 2280 HV Rijswijk
Tel. (+31-70) 340-2040, Tx. 31 651 epo nl,
Fax: (+31-70) 340-3016

Authorized officer

Coda, R

INTERNATIONAL SEARCH REPORT

 Internatic _ application No
 PCT/IB 03/03614

C.(Continuation) DOCUMENTS CONSIDERED TO BE RELEVANT

| Category ° | Citation of document, with indication, where appropriate, of the relevant passages | Relevant to claim No. |
|------------|---------------------------------------------------------------------------------------------------------------------------------------------------------------------------------------------------------------------------------------------------------------------------------------------------------------------------------------------------------------------------------------------------------------|-----------------------|
| Y | US 2001/033133 A1 (JUSTEL THOMAS ET AL) 25 October 2001 (2001-10-25) paragraphs '0009!', '0027!' --- | 2 |
| A | HORCHANI K ET AL: "Scintillation properties of CsPrP4012 and RbPrP4012" NUCLEAR INSTRUMENTS & METHODS IN PHYSICS RESEARCH, SECTION - A: ACCELERATORS, SPECTROMETERS, DETECTORS AND ASSOCIATED EQUIPMENT, NORTH-HOLLAND PUBLISHING COMPANY. AMSTERDAM, NL, vol. 486, no. 1-2, 21 June 2002 (2002-06-21), pages 283-287, XP004367489 ISSN: 0168-9002 the whole document --- | 1-9 |
| A | DORENBOS P ET AL: "Scintillation properties of some Ceand Prdoped inorganic crystals" NUCLEAR SCIENCE SYMPOSIUM AND MEDICAL IMAGING CONFERENCE, 1992., CONFERENCE RECORD OF THE 1992 IEEE ORLANDO, FL, USA 25-31 OCT. 1992, NEW YORK, NY, USA, IEEE, US, 25 October 1992 (1992-10-25), pages 281-283, XP010108406 ISBN: 0-7803-0884-0 the whole document ----- | 1-9 |

INTERNATIONAL SEARCH REPORT

International Application No
PCT/IB 03/03614

| Patent document cited in search report | Publication date | Patent family member(s) | Publication date |
|----------------------------------------|------------------|-------------------------|------------------|
| US 2001006214 A1 | 05-07-2001 | DE 19961673 A1 | 28-06-2001 |
| | | EP 1111405 A2 | 27-06-2001 |
| | | JP 2001228254 A | 24-08-2001 |
| US 2001033133 A1 | 25-10-2001 | DE 10009916 A1 | 13-09-2001 |
| | | EP 1130621 A2 | 05-09-2001 |
| | | JP 2001283739 A | 12-10-2001 |