

(No Model.)

2 Sheets—Sheet 1.

J. F. KUHLMAN.

WASHING MACHINE.

No. 358,400.

Patented Feb. 22, 1887.

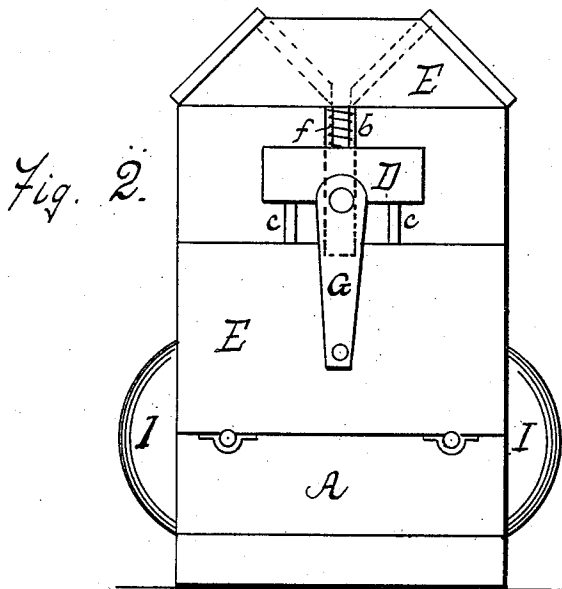
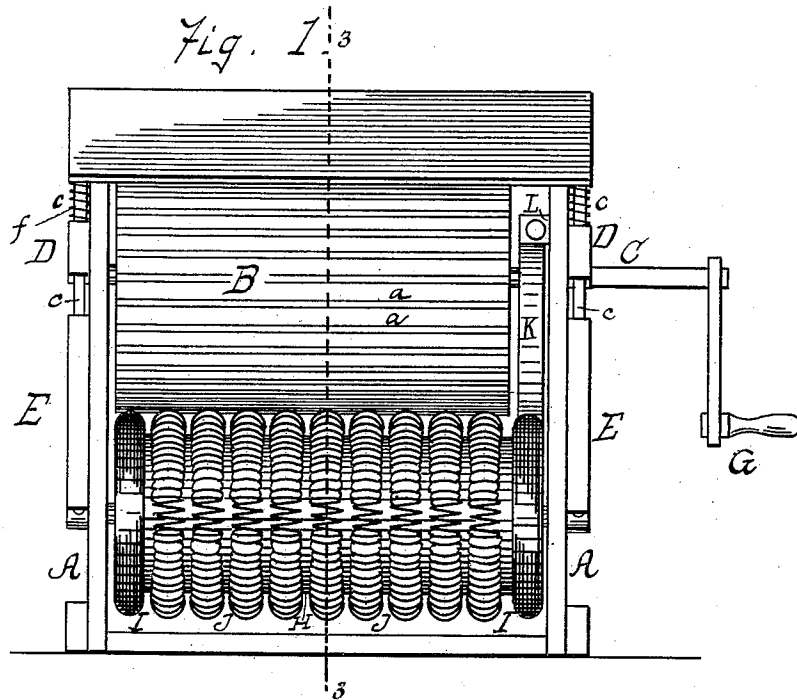

Witnesses  
*[Signature]*  
*[Signature]*

Inventor  
Joseph Frederick Kuhlman.  
By his Attorneys  
*[Signature]*

J. F. KUHLMAN.  
WASHING MACHINE.

No. 358,400.

Patented Feb. 22, 1887.

*Fig. 3.*

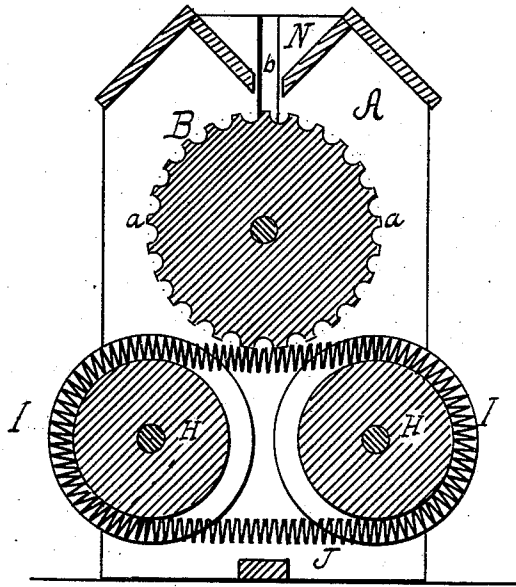

*Fig. 4.*

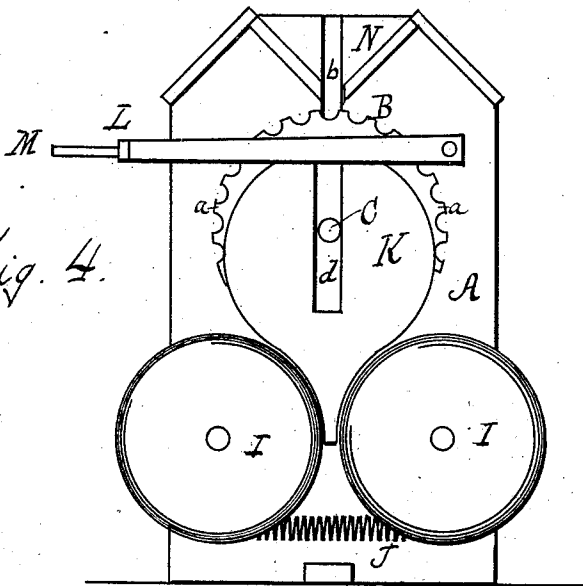

Witnesses  
*[Signature]*  
*[Signature]*

Inventor  
 Joseph Frederick Kuhlman.  
 By *[Signature]* Attorneys  
*[Signature]*

# UNITED STATES PATENT OFFICE.

JOSEPH FREDERICK KUHLMAN, OF ANAMOSA, IOWA.

## WASHING-MACHINE.

SPECIFICATION forming part of Letters Patent No. 358,400, dated February 22, 1887.

Application filed April 13, 1886. Serial No. 198,660. (No model.)

*To all whom it may concern:*

Be it known that I, JOSEPH FREDERICK KUHLMAN, a citizen of the United States, residing at Anamosa, in the county of Jones and State of Iowa, have invented certain new and useful Improvements in Washing-Machines; and I do declare the following to be a full, clear, and exact description of the invention, such as will enable others skilled in the art to which it appertains to make and use the same, reference being had to the accompanying drawings, and to the letters and figures of reference marked thereon, which form a part of this specification.

This invention relates to that class of washing-machines wherein a rotatable ribbed roller co-operates with an endless traveling bed to scrub and clean the clothes.

The present invention consists in an improved construction of the traveling bed, and in a brake mechanism by means of which the belt may be held stationary, whereby a particular spot of the fabric being washed may be subjected for a longer period to the action of the ribbed roller.

This improved washing-machine is illustrated in the accompanying drawings, in which Figure 1 is a front view of the washing mechanism. Fig. 2 is an end view thereof; Fig. 3, a central vertical section in a plane indicated by the line 3 3 in Fig. 1, and Fig. 4 a side view with the framing removed.

The washing mechanism here illustrated is shown as mounted in a frame-work which is adapted to be placed within a tub in which the washing is to be done. The frame-work consists of two side frames, A A, suitably connected together and braced. Journalled between these side frames is the rotary roller B, having the usual longitudinal ribs, *a a*. The shaft C of this roller passes through slots *b b* in the side frames, and is yieldingly mounted in sliding blocks D D, located outside of the side frames. Each of these blocks D has short rods *c c* secured thereto, which enter and slide in suitable apertures in plates E E, secured to the side frames. Surrounding the rod *c*, and held between the sliding block D and upper plate, E, is a coiled spring, *f*, which presses the block D downward, thus giving a yielding downward pressure to the ribbed roller B. To

one end of the shaft C is secured the operating-crank handle G.

Beneath the ribbed roller two drums, H H, in the same horizontal plane, are rotatively mounted in the side frames, A A. Each of these drums carries at each end a projecting wheel, I. These two drums carry the endless traveling scrubbing-bed. This bed is made up of a series of independent endless coiled wire springs, J J, placed side by side. These springs are retained on the drums and held in proper position by the projecting wheels I. These springs pass beneath the roller B, and upon them the roller presses, owing to the tension of the coiled springs F. The rotation of the roller B causes the spring-bed to travel, the drums H H turning easily for that purpose.

In using the machine the tub is filled with sufficient water to cover the traveling spring-bed. The clothes to be washed are then placed upon the bed, and the turning of the crank-handle G causes the clothes to be carried between the spring-bed and the ribbed roller. Through the action of the bed and roller the clothes are thoroughly rubbed and cleansed. This spring-bed offers many advantages. The coiled springs offer a ribbed or corrugated surface upon which the clothes are rubbed, and at the same time a yielding surface which enables different thicknesses of cloth to be cleaned without injury and with ease. The spring-bed also permits the dirt from the clothes to fall at once to the bottom of the tub and admits a free circulation of the water. The independence of each coiled spring-belt from the others constituting the bed is also an important feature, since an independent movement of each spring is thus possible, which is of great advantage in washing garments which present different thicknesses and folds in their widths. Each spring, thus yielding and traveling independently, equalizes the pressure upon different portions of the cloth under treatment, and renders the operation of the machine uniform and steady.

When a portion of a fabric is more soiled than the rest of it, as is often the case, it is desirable that such portion should be subjected for a longer period to the scrubbing action of the roller and bed. To that end I provide a brake mechanism by means of which the move-

ment of the traveling bed may be retarded or entirely stopped. My brake consists of a cam-shaped block, K, which rests upon two of the wheels I I of the drums H H. This block is retained in position by occupying the space between one end of the ribbed roller B and one of the side frames, A. A slot, *d*, is cut in the block K, through which the shaft C of roller B extends, and which permits a free vertical movement of the block. Above this block is a lever, L, which at one end is pivoted to the inner side of one of the side frames, A. Its other end is shaped to constitute a handle, M. This lever usually rests upon the block K, which in turn rests upon the wheels I; but they are so light as to interfere to no practical extent with the free movement of the drums H H. When, however, it is desired to retard or stop the movement of the drums, a downward pressure upon the handle M of the lever will control the movement of the drum to the desired extent. When the movement of the spring-bed has been stopped, that part of the fabric beneath the roller B may be scrubbed until thoroughly cleansed.

The upper portion of the frame-work is shaped to constitute a convenient soap-trough, N.

I am aware that ribbed rollers have been used with endless traveling beds, and I am also aware that ribbed rollers have been used

with stationary beds made of coiled wire springs, and I therefore make no claim to cover such constructions; but

What I do claim is—

1. In a washing-machine, rotating drums, an endless traveling bed carried by said drums, and a rotating rubbing-roller in frictional contact with said bed, in combination with a brake-block resting upon said drums, and a lever for applying pressure to said brake, substantially as set forth.

2. In a washing-machine, side frames, A A, a rotating ribbed roller, B, mounted in yielding bearings carried by said frames, rotating drums H H, mounted in said frames beneath said roller B, wheels I I upon the ends of said drums, and an endless bed composed of coiled springs J J, which pass around said drums in frictional contact with said roller B, in combination with a brake-block, K, which rests upon said wheels I I, and a pivoted lever, L, resting upon said block K, whereby pressure may be applied to said brake and the rotation of said drums H H may be retarded or stopped, substantially as set forth.

In testimony whereof I affix my signature in presence of two witnesses.

JOSEPH FREDERICK KUHLMAN.

Witnesses:

JOHN G. CUDWORTH,

W. F. QUIGLEY.