

Nov. 18, 1924.

1,515,827

R. E. BRESSLER

RAILROAD WAY CONSTRUCTION AND MAINTENANCE CAR

Filed Dec. 22, 1920

4 Sheets-Sheet 1

Fig. 1.

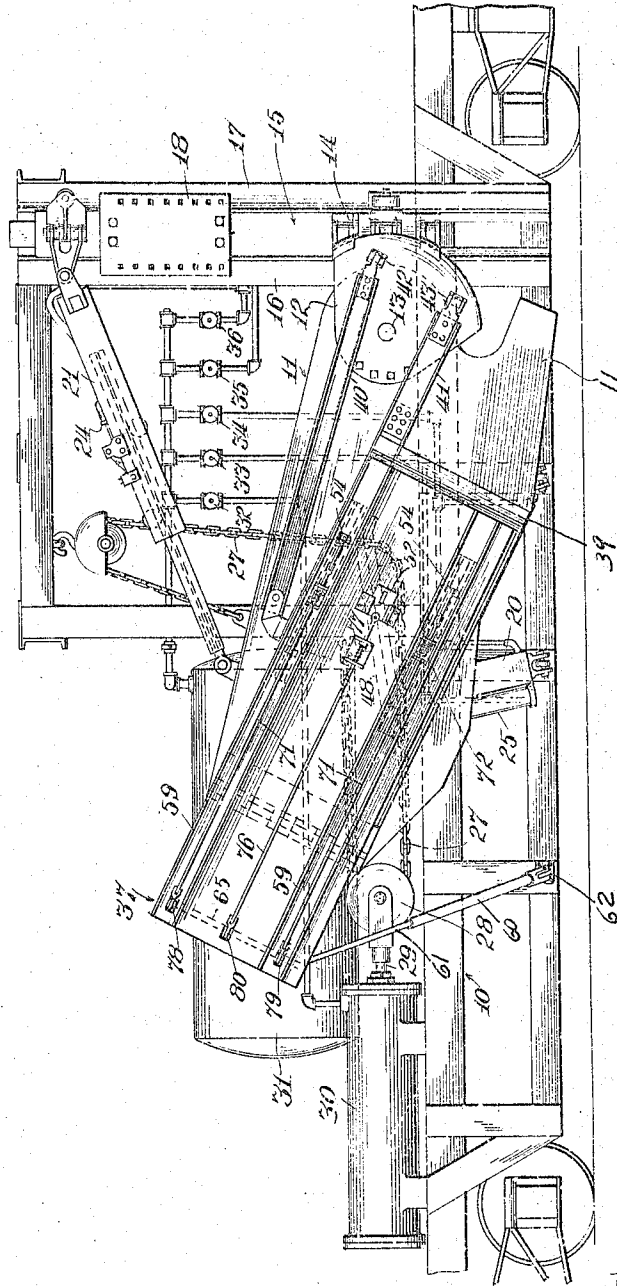

Witness
Milton Lenoir

Inventor
Robert E. Bressler,
Attorney
James Lawson,
Attorneys

Nov. 18, 1924.

1,515,827

R. E. BRESSLER

RAILROAD WAY CONSTRUCTION AND MAINTENANCE CAR

Filed Dec. 22, 1920

4 Sheets-Sheet 2

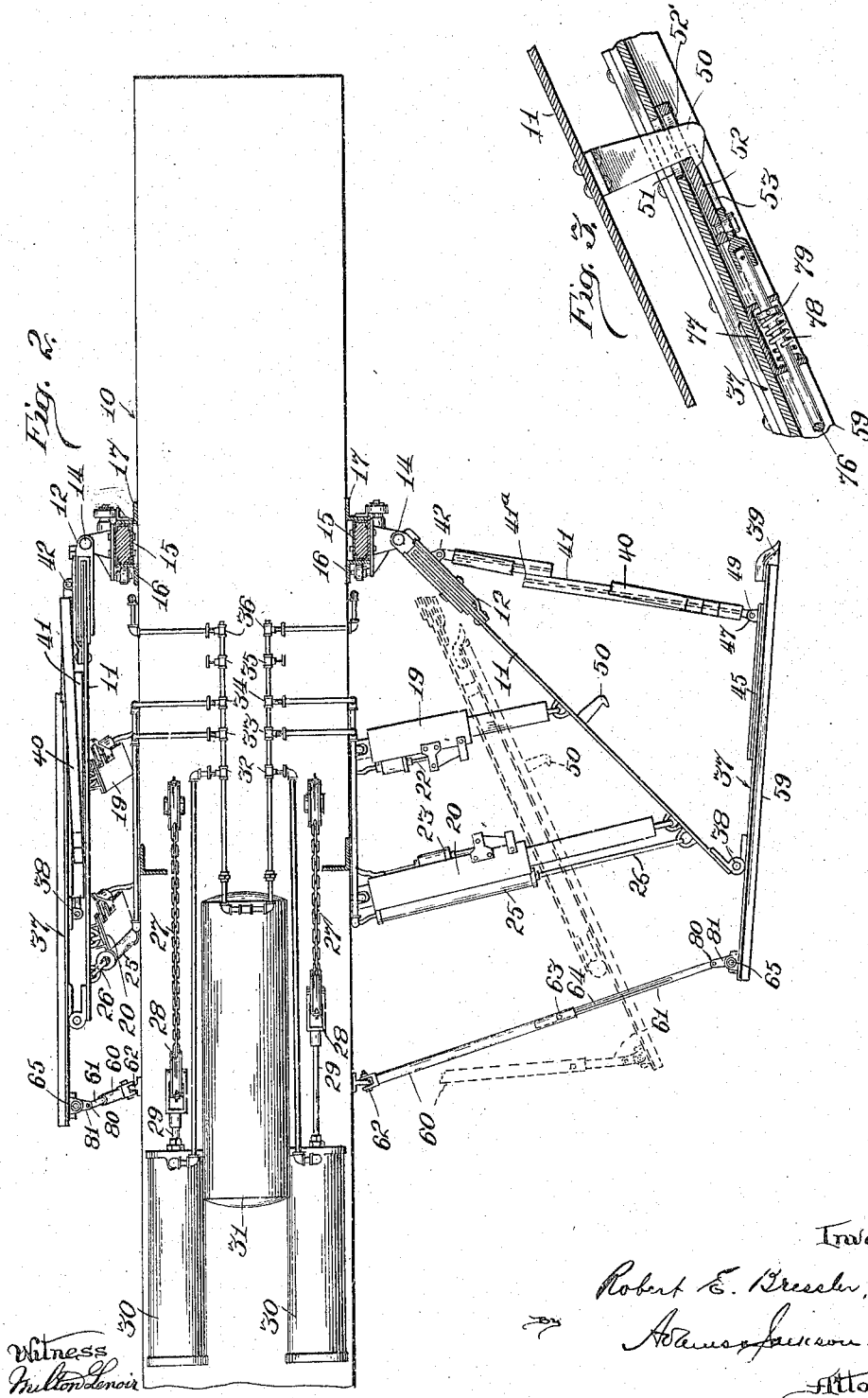

Witness
M. L. Anderson

Inventor

Robert E. Bressler,

Hans Jackson.

Attorney.

Nov. 18, 1924.

1,515,827

R. E. BRESSLER

RAILROAD WAY CONSTRUCTION AND MAINTENANCE CAR

Filed Dec. 22, 1920

4 Sheets-Sheet 3

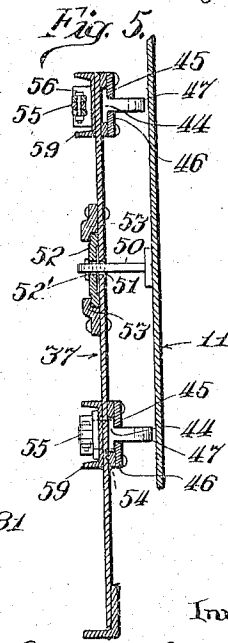
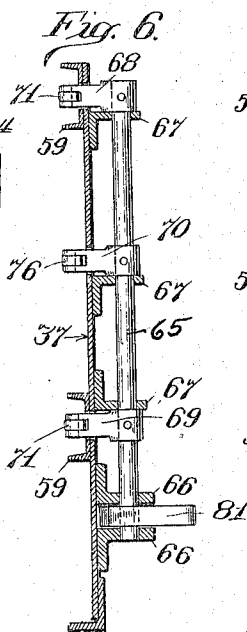
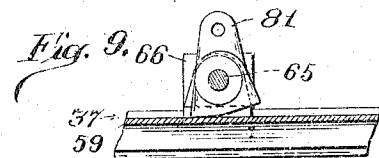
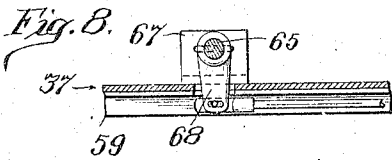
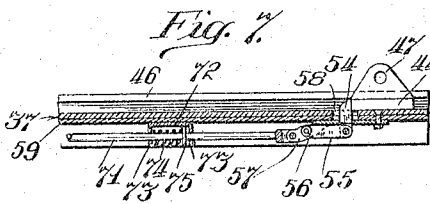
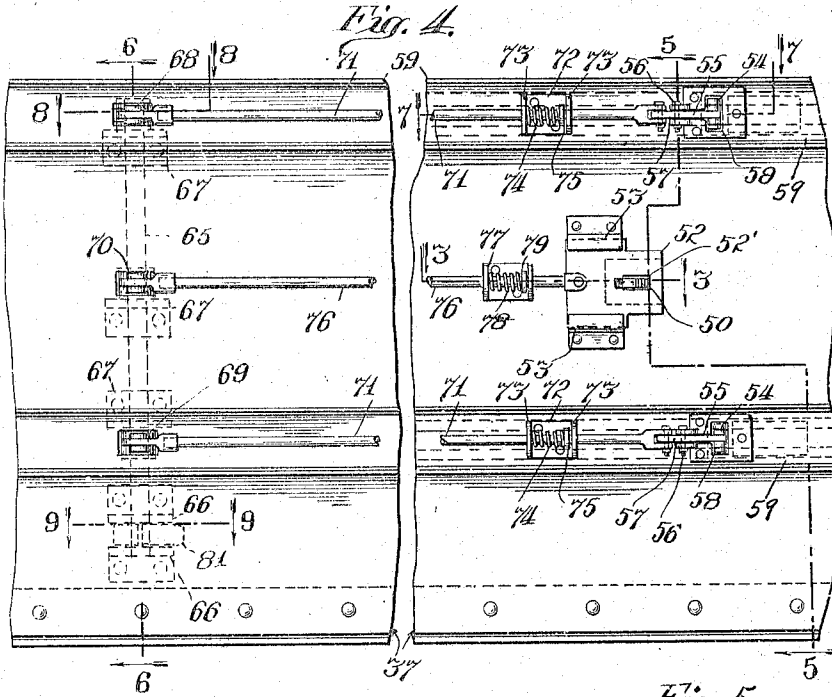

Witness
Milton Lenoir

Inventor
Robert E. Bressler,
Adams & Jackson,
Attorneys

Nov. 18, 1924.

1,515,827

R. E. BRESSLER

RAILROAD WAY CONSTRUCTION AND MAINTENANCE CAR

Filed Dec. 22, 1920

4 Sheets-Sheet 4

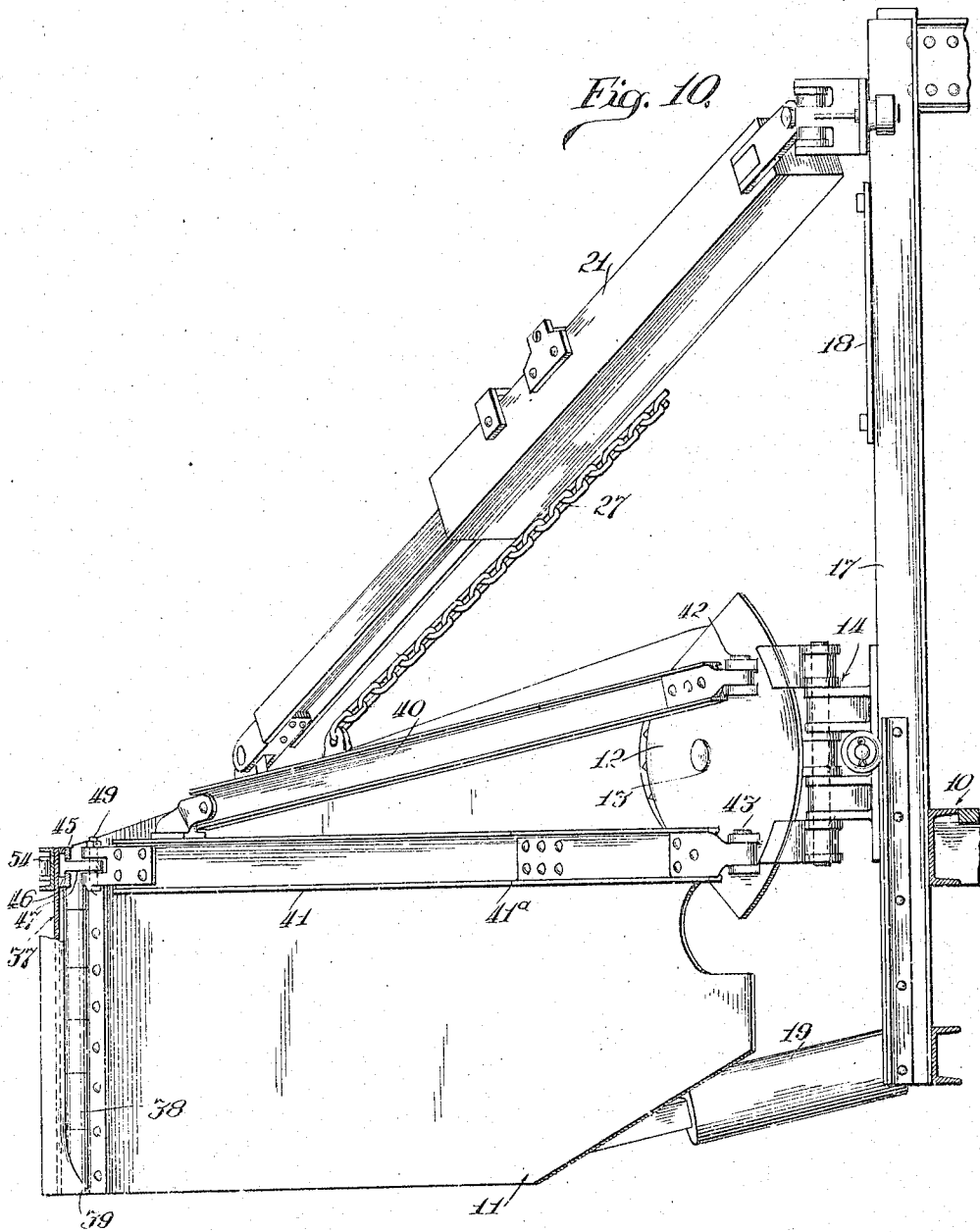

Fig. 10.

Inventor

Robert E. Bressler

By Adams & Jackson

Attorneys

*Witness
W. H. Lenoir*

UNITED STATES PATENT OFFICE.

ROBERT E. BRESSLER, OF AURORA, ILLINOIS, ASSIGNOR TO WESTERN WHEELED
SCRAPER COMPANY, OF AURORA, ILLINOIS, A CORPORATION OF ILLINOIS.

RAILROAD WAY CONSTRUCTION AND MAINTENANCE CAR.

Application filed December 22, 1920. Serial No. 432,481.

To all whom it may concern:

Be it known that I, ROBERT E. BRESSLER, a citizen of the United States, and a resident of Aurora, in the county of Kane and State of Illinois, have invented certain new and useful Improvements in Railroad Way Construction and Maintenance Cars, of which the following is a specification, reference being had to the accompanying drawings.

My invention relates to railway cars used for grading and road maintenance work, and has particularly to do with cars provided with means for spreading or grading earth along the right of way. Such cars usually comprise wings mounted at one or both sides of the car and connected at one end with the car by pivotal connections arranged to permit the wing either to be extended at a greater or less angle with the car while occupying a horizontal or approximately a horizontal position, or to be raised and swung back substantially parallel with the sides of the car when not in use. These wings are necessarily made strong and heavy in order to withstand the heavy strains to which they are subjected when in use, and are provided with braces which hold them firmly in operative position and at the same time are so constructed that they do not interfere with the raising and folding back of the wings when that operation is to be performed. The pivotal connections about which the wings swing are also usually arranged to be vertically adjustable so that the height of the inner end of the wings may be regulated to suit varying conditions.

My present invention has to do with cars of this general type and has for its object to provide the spreading or grading wings with auxiliary wings disposed at their outer ends and arranged to retain and carry material along so that it may be deposited in low spots along the right of way or discharged in a fill, in connection with means for holding such material carrying wings firmly in operative position when the grader wings are extended, and for folding them into a position substantially parallel with the grader wings when the latter are swung back out of operative position. The several improvements by which I accomplish this object will clearly appear from the following description of the embodiment thereof illustrated in the accompanying drawings, in

which I have illustrated them as applied to a car equipped with compressed air actuated mechanism for operating the grader wings which is fully shown and described in my pending application, Serial No. 421,845, filed November 5, 1920. It should be understood, however, that the improvements which constitute the subject-matter of my present application may be applied to the grader or spreader wings of cars equipped with other forms of operating mechanism by which said wings may be swung toward or from the sides of the car.

In the accompanying drawings,—

Fig. 1 is a side elevation of my improved car showing the spreader wing and material carrying wing at one side thereof in their folded or inoperative positions;

Fig. 2 is a diagrammatic plan view showing the wings at one side of the car folded, and those at the other side thereof extended in operative position, certain parts being in section and one of the forward braces for the material carrying wing being partly broken away;

Fig. 3 is a detail, being a partial horizontal section on line 3—3 of Fig. 4;

Fig. 4 is an enlarged detail, being a partial side elevation of the outer surface of one of the material carrying wings, some parts being broken away;

Fig. 5 is a vertical section on line 5—5 of Fig. 4;

Fig. 6 is a vertical section on line 6—6 of Fig. 4;

Fig. 7 is a partial longitudinal section on line 7—7 of Fig. 4;

Fig. 8 is a partial longitudinal section on line 8—8 of Fig. 4;

Fig. 9 is a partial longitudinal section on line 9—9 of Fig. 4; and

Fig. 10 is an enlarged detail, being a front view of the wings and their braces at one side of the car with some parts in section, the view being substantially one as seen from the right of Fig. 2.

Referring to the drawings,—10 indicates the body or frame of a car which is of any suitable construction to support the side wings and the operating mechanism thereof. 11 indicates the spreader or grader wings, two of which are provided disposed at opposite sides of the car, and so mounted that their rear ends are capable of swinging toward and from the car and also ver-

tically. This is best accomplished by connecting the forward end of each wing 11 to a hinged plate 12 by means of a horizontal pivot 13, the plate 12 being connected
 5 by hinges 14 with a sliding block 15 mounted to slide vertically between upright guides 16, 17 secured at the side of the car. By this construction the wing 11 is capable of swinging laterally about the hinges 14
 10 and vertically about the pivot 13, and its forward end is capable of being adjusted vertically. I prefer also to provide a locking plate 18 by which the sliding block 15 may be secured at different heights. For
 15 moving the spreader wing 11 into or out of its operative position and holding it in its different positions, I prefer to employ telescopic braces 19, 20 and 21 provided with compressed air actuated locking devices 22,
 20 23 and 24, and with a compressed air operated cylinder 25 and plunger 26. The plunger 26 serves to extend the wing 11, the braces 19, 20 hold it in its extended position, and the brace 21 holds it against upward
 25 movement except when the several locking devices are released by the operation of the compressed air actuated mechanism to permit the wing to be retracted and swung upwardly to the position shown in
 30 Fig. 1. This retraction and elevation of the wing are accomplished by the operation of a cable 27, one end of which is connected with the upper portion of the wing and the other end with a fixed support. The cable
 35 operates over suitable pulleys and is actuated by a pulley 28 carried by a plunger rod 29 operating in a compressed air actuated cylinder 30 shown in Fig. 1. Compressed air is supplied from a reservoir 31, and
 40 suitable valves 32, 33, 34, 35 and 36 are provided for controlling the admission of compressed air to the several compressed air operated devices by which the different movements of the spreader wing are controlled. The details of the mechanism
 45 which I prefer to employ for this purpose, and which is illustrated in a general way in the drawings, are all fully shown and described in my said pending application, and it is not believed to be necessary to illustrate
 50 and describe them here, as my present invention is not dependent upon the specific mechanism employed for controlling the operation of the spreader wing, it being essential only that it be capable of swinging
 55 laterally and vertically in the manner described.

Coming now to the improvements which constitute the subject-matter of my present invention,—37 indicates my improved material carrying wing, which, as shown in Fig. 1, is similar in shape to the spreader wing 11 and is preferably a rectangular metal plate of suitable dimensions. The
 60 wing 37 is connected between its ends, and

preferably near its rear end, with the outer end portion of the spreader wing 11 by a vertical hinge 38 so that the material carrying wing is capable of being folded up
 against the spreader wing substantially 70 parallel therewith, as indicated by dotted lines in Fig. 2, or of being extended relatively thereto to form a pronounced angle therewith, as shown in full lines in said figure. At its forward end the wing 37 is
 75 provided with a plow or earth cutting member 39, as shown in Figs. 1 and 2. The forward end portion of the material carrying wing 37 is held in operative position when extended by a pair of rearwardly converg-
 80 ing braces 40, 41, preferably in the form of channel bars, which are connected with the hinged plate 12 by hinges 42, 43, as shown in Figs. 1 and 10, the rear ends of said braces being pivotally connected with sliding plates
 85 44 mounted to slide longitudinally of the inner surface of the wing 37. The arrangement of these plates is best shown in Fig. 5, from which it will be seen that they bear against the surface of the wing 37 and
 90 are held in position and guided by separated guide plates 45, 46 arranged in pairs and secured to the wing 37. One of these plates 44 is preferably placed near the upper margin of the wing 37 and the other somewhat
 95 below the vertical center of said wing, and they are provided with lugs or ribs 47 which project through the spaces between the guides 45, 46 and serve as means for the attachment of the operative connections of
 100 said plates. As indicated by dotted lines in Fig. 1, the upper and lower plates 44 are connected together by a cross-connection 48, and the braces 40, 41 are pivotally connected to the lug 47 of the upper plate by a pivot
 105 49, as shown in Figs. 2 and 10. The arrangement is such that when the material carrying wing 37 is in its extended or operative position the pivot 49 is near the forward end of said wing and the braces 40, 41 are
 110 approximately perpendicular to the plane of said wing. Said braces, therefore, serve to hold the forward portion of the wing against further outward movement, and when the plates 44 are locked in position, as will be
 115 hereinafter described, they also serve to hold the wing against inward movement. When, however, said plates are released so that they are free to slide rearwardly along the wing the forward portion of the wing may be
 120 swung toward the spreader wing 11 until it is substantially parallel therewith. In order to permit the wing 37 to lie closely against the wing 11 the brace 41 is preferably offset as shown at 41^a in Fig. 2 to
 125 provide a space to accommodate the projecting portion of the hinge plate 12. When the wing 37 is swung into parallel relation with the spreader wing 11 it is automatically locked in such position by means of a fixed
 130

hook 50 which is secured to the intermediate portion of the outer or forward face of the wing 11, as shown in Figs. 2 and 3, and is adapted to project through a slot 51 in the material carrying wing 37 and to be engaged by a latch plate 52 mounted to slide on the outer face of the latter wing, as best shown in Figs. 3 and 5. This latch plate is fitted between guides 53 and is preferably provided with a slot 52' through which the hook 50 projects when in operative position, as shown in Fig. 3. The slot 52' is made long enough so that the latch plate 52 may be moved longitudinally of the wing 37 far enough to permit the hook 50 to disengage it, thereby permitting the wing 37 to be swung outwardly away from the wing 11. The devices for operating the latch plate 52 will presently be described.

The sliding plates 44 are arranged to be locked in position when the wing 37 is extended to its operative position, by means of bolts 54 pivotally connected with the forward end portions of bell-crank levers 55 which are pivotally mounted upon the outer face of the wing 37 by pivots 56 shown in Fig. 7, the arrangement being such that by pulling back upon the rearwardly-extending arm 57 of said levers the bolts 54 may be moved perpendicularly with reference to the wing 37. When the bolts 54 are in operative position they extend through slots 58 in the wing 37 adjacent to the lugs 47 carried by the sliding plates 44, as best shown in Fig. 7, thereby preventing rearward movement of said plates. When, however, the bolts 54 are withdrawn from the slots 58 by the actuation of the bell-crank levers 55 the plates 44 are free to slide rearwardly as the forward end of the wing 37 is swung toward the wing 11. Preferably the levers 55, as well as the operating parts therefor hereinafter described, are mounted between the flanges of channel bars 59 which extend longitudinally of the wing 37, as shown in Figs. 4 and 5, and serve to reinforce said wing.

The bolts 54 and also the latch plate 52 are automatically operated to release the parts which they severally engage when the spreader wing 11 is swung inwardly out of operative position by mechanism which will now be described.

60, 61 indicate the members of a telescopic brace or thrust bar which at its inner end is pivoted at one side of the car so that it is free to swing laterally and vertically, as shown at 62. The member 61 is adapted to slide in the member 60 within certain limits, its range of movement being limited by a pin 63 in the member 60 which passes through a longitudinal slot 64 in the member 61. The outer end of the member 61 is connected by a pivot 80 to the outer end of a rocking lever 81 which is mounted upon

and non-rotatably secured to the lower end of a pivot rod 65 and extends between brackets 66 secured to the rear end portion of the wing 37, which, as shown in Fig. 2, extends some little distance back of the hinge 38. The lever 81 is mounted between its ends upon the rod 65, which extends parallel with the rear edge of the wing 37, and the inner end of said lever is rounded or inclined at its forward side so that when said lever stands substantially perpendicularly with relation to the wing 37 it cannot swing to the left as viewed in Fig. 9, but is capable of swinging to a limited extent to the right. As shown in Fig. 6, the brackets 66 are located near the lower edge of the wing 37 and the pivot rod 65 extends up to near the upper edge of said wing, being journaled in brackets 67 secured at intervals to said wing. Said rod is provided with rigidly attached arms 68, 69, 70 which extend through slots in the wing 37, as shown in Fig. 6. The uppermost arm 68 and the lowermost arm 69 are connected respectively with rods 71 which extend longitudinally of the wing 37 between the flanges of the channel bars 59, as best shown in Fig. 4, and are connected with the rearwardly extending arms 57 of the bell-crank levers 55. Intermediately of the length of the rods 71 brackets 72 are secured to the channel bars 59 having outwardly projecting flanges 73 through passages in which the rods 71 extend. Between the arms of each bracket 73 a spring 74 is mounted which at one end bears against one of the flanges 73 and at the other end bears against a collar 75 carried by the rod 71, so that said spring tends to move the rod 71 toward the right as viewed in Fig. 4 and therefore to actuate the bell-crank levers 55 to move the bolts 54 carried thereby into operative position. In like manner the arm 70 carried by the pivot rod 65 is connected by a rod 76 with the locking plate 52, as shown in Fig. 4, and said rod passes through a guide bracket 77 similar to the bracket 72, and is provided with a spring 78 and collar 79 similar to the spring 74 and collar 75. The spring 78, therefore, tends to move the locking plate 52 to the right, as viewed in Fig. 4, or in other words to hold it in locking position, as will be clearly understood from an inspection of Figs. 3 and 4.

When the parts are in operative position, shown in full lines in Fig. 2, the brace member 61 is extended to its extreme position and the pivot 80 lies forward of a line intersecting the pivot 62 and the pivot rod 65. At this time the wing 37 is held in its operative position by the braces 40, 41, which resist swinging movement of said wing in either direction, and also by the brace comprising members 60, 61 which resists inward swinging of the forward portion of said wing. When, with the parts in this posi-

tion, the side wing 11 is swung inwardly and upwardly toward the car the wing 37 does not change its angular relation to the wing 11 until the brace member 61 is moved into the brace member 60 to the limit of its movement, this inward movement of the brace member 61 being caused by the inward movement of the wing 11. As soon as the outer end of the slot 64 in the brace member 61 engages the pin 63, further inward movement of the brace member 61 is prevented, and as the wing 11 continues to swing inwardly the brace members 60, 61 operate as a thrust bar which acts upon the lever 81 in such manner as to tend to rotate said lever in a clockwise direction, as viewed in Fig. 2. This causes the arms 68, 69, 70 carried by the rod 65 to swing to the left as viewed in Figs. 4 and 8, thereby releasing the locking devices controlled by them. The release of the sliding plates 44 permits said plates to slide rearwardly along the wing 37 and consequently said wing is free to swing into parallelism with the wing 11 under the action of gravity and the thrust of the thrust bars 60, 61. When the wing 37 moves into approximate parallelism with the wing 11 the hook 50 passes through the slot 51 in the wing 37 and into position to be engaged by the latch-plate 52, and as the inward swinging of the wing 37 operates to draw the member 61 somewhat out of the member 60 the lever 81 is relieved from pressure and consequently is free to rock in the opposite direction under the action of the springs 74, 78. The latch plate 52 is, therefore, caused to move into engagement with the hook 50, thereby locking the wing 37 in parallelism with the wing 11. When the parts are in this position, as shown by dotted lines in Fig. 2, the outward swinging of the rear end of the wing 37 carries the pivot 80 to the rear of a line intersecting the pivots 62 and 65, and, therefore, when the spreader wing 11 is again swung outwardly toward its operative position the member 61 is first drawn out of the member 60 to the limit of its movement, and when the pin 63 reaches the inner end of the slot 64 further outward movement of the wing 11 exerts a pull upon the lever 81 which tends to rock it in a clockwise direction as viewed in Fig. 2, thereby operating said lever to move the locking plate 52 out of engagement with the hook 50. This releases the material carrying wing 37 so that upon further outward movement of the wing 11 the material carrying wing is swung outwardly into its operative position, and this outward swinging of the wing 37 causes the sliding plates 44 to move forward along said wing until they reach the position shown in full lines in Fig. 2. The early part of the outward turning movement of the wing 37 releases the pull upon the member 61 and consequently under

the action of the springs 74 the levers 55 are rocked to carry the bolts 54 into locking position. These bolts are bevelled as shown in Fig. 7 so that the sliding plates 44 may trip past them into the locking position shown in said figure.

From the foregoing description it will be seen that the material carrying wing 37 is automatically moved into or out of operative position; that when in its operative position it is locked against movement in either direction with reference to the spreader wing 11; and that when said spreader wing is moved into its inoperative position the material carrying wing is automatically folded against it and is locked in such folded position. So far as I am aware I am the first in the art to provide a material carrying wing operating in this way, and the claims hereinafter made are, therefore, to be construed generically, except in so far as they may be directed to specific features of construction shown and described.

What I claim as my invention and desire to secure by Letters Patent, is—

1. A car in combination with a side wing, a material carrying wing pivoted to the side wing and extending across the outer end thereof, and a brace extending between said wings.
2. A car in combination with a side wing, a material carrying wing pivoted to the side wing and extending across the outer end thereof, braces extending between the side wing and the car, and means for swinging the side wing to substantially parallel relation with the car.
3. A car in combination with a side wing, a material carrying wing intermediately pivoted to the outer end of the side wing, and a telescopic brace connecting the rear end of the material carrying wing and the car.
4. A car in combination with a side wing pivotally connected thereto, a material carrying wing pivotally connected intermediately thereof to the side wing, braces connecting the side wing and the car, and means connecting the rear end of the material carrying wing and the car whereby the material carrying wing is swung to substantially parallel relation with the side wing when the side wing is swung inwardly.
5. A car in combination with a side wing pivotally connected thereto, a material carrying wing pivotally connected to the side wing, a brace connecting the material carrying wing and the side wing and having a sliding connection with said side wing, and a guide on the material carrying wing for guiding the movement of said brace.
6. A car in combination with a side wing pivotally connected thereto, a material carrying wing pivoted to the side wing, a brace

connecting the side wing and the material carrying wing and having a sliding connection with said side wing, a guide on the material carrying wing for guiding the movement of said brace, and means for locking said brace in operative position.

7. A car in combination with a side wing pivotally connected thereto, a material carrying wing pivotally connected to the side wing, a brace connecting the material carrying wing and the side wing, a guide mounted on the material carrying wing for guiding the movement of said brace, locking means for holding said brace in operative position, and automatic means for releasing said lock when said wings are swung inwardly toward the car.

8. A car in combination with a side wing pivotally connected thereto, a material carrying wing pivotally connected to the side wing, and automatically interlocking means mounted respectively on the side wing and on the material carrying wing for locking said wing to the side wing when it is brought into substantially parallel relation thereto.

9. A car in combination with a side wing pivotally connected thereto, a material carrying wing pivotally connected to the side wing, locking means mounted on the material carrying wing for locking said wing to the side wing when it is brought into substantially parallel relation thereto, and automatic means for releasing said lock when the side wing is swung outwardly.

10. A car in combination with a side wing pivotally connected thereto, a material carrying wing pivotally connected to the side wing, a brace extending between said wings, locking means for locking said brace in operative position, locking means for locking said wings in parallel relation to each other, and means actuated by swinging movement of the side wing for releasing said locks.

11. A car in combination with a side wing pivotally connected thereto, a material carrying wing pivotally connected intermediately thereof to the side wing, a brace connecting the rear end of the material carrying wing and the car, a connection between said brace and said material carrying wing arranged so that movement of said material carrying wing will rock said connection, and locking devices for said material carrying wing controlled by said connection.

12. A car in combination with a side wing pivotally connected thereto, a material carrying wing pivotally connected to the side wing forward of the rear end of the material carrying wing, a lever positively connected to a shaft and pivotally connected to the material carrying wing, a brace telescopically connecting said lever and the car whereby swinging movement is imparted to said lever when swinging movement is imparted to the side wing, and locking devices

for said material carrying wing controlled by said lever.

13. A car in combination with a side wing pivotally connected thereto, a material carrying wing pivotally connected intermediately thereof to the side wing, a telescopic brace connecting the rear end of the material carrying wing and the car, a lever pivotally connected to said brace, a shaft positively connected to said lever, arms positively connected to said shaft so that rotary movement is imparted to said arms when swinging movement is imparted to the side wing, and locking devices for said material carrying wing controlled by said arms.

14. A car in combination with a side wing pivotally connected thereto, a material carrying wing pivotally connected intermediately thereof to the side wing, a telescopic brace connecting the rear end of the material carrying wing and the car, a lever pivotally connected to said brace, a shaft positively connected to said shaft so that rotary movement of said shaft imparts rotary movement to said arms, locks for locking the material carrying wing in extended and retracted position, and means connecting said arms with said locks and operating so that said locks are caused to release automatically when swinging movement is imparted to the side wing.

15. A car in combination with a side wing pivotally connected therewith, means mounted on the car for swinging said wing into or out of operative position, a material carrying wing pivotally connected with the outer portion of said side wing to swing toward or away therefrom, and longitudinally-extensible means actuated by the swinging of said side wing for aiding in controlling the movement of said material carrying wing into or out of operative position.

16. A car in combination with a side wing pivotally connected therewith, means mounted on the car for swinging said wing into or out of operative position, a material carrying wing pivotally connected with the outer portion of said side wing to swing toward or away therefrom, longitudinally-extensible means actuated by the swinging of said side wing for aiding in controlling the movement of said material carrying wing into or out of operative position, and means controlled by said extensible means for locking the latter wing in operative position.

17. A car in combination with a side wing pivotally connected therewith, means mounted on the car for swinging said wing into or out of operative position, a material carrying wing pivotally connected with the outer portion of said side wing to swing toward or away therefrom, longitudinally-extensible means actuated by the swinging of said side wing for aiding in controlling the

movement of said material carrying wing into or out of operative position, and means controlled by said extensible means for locking the latter wing in inoperative position.

5 18. A car in combination with a side wing pivotally connected therewith, means mounted on the car for swinging said wing into or out of operative position, a material carrying wing pivotally connected with the
10 outer portion of said side wing to swing toward or away therefrom, longitudinally-extensible means actuated by the swinging of said side wing for aiding in controlling the movement of said material carrying
15 wing into or out of operative position, means for locking the latter wing in operative position, and means for locking the latter wing in inoperative position, both of said locking means being controlled by said longitudinally-extensible means.

19. A car in combination with a side wing pivotally connected therewith, means mounted on the car for swinging said wing into or out of operative position, a material carrying wing pivotally connected with the
25 outer portion of said side wing to swing toward or away therefrom, extensible bracing means connected with one end portion of the material carrying wing and actuated by the swinging of said side wing for aiding in
30 controlling the movement of said material carrying wing into or out of operative position, and means connected with the other end portion of the material carrying wing for bracing the material carrying wing in operative position.

20. A car in combination with a side wing pivotally connected therewith, means mounted on the car for swinging said wing into or out of operative position, a material carrying wing pivotally connected with the
40 outer portion of said side wing to swing toward or away therefrom, means actuated by

the swinging of said side wing for moving said material carrying wing into or out of
45 operative position, means for locking the latter wing in operative position, and means actuated by movement of the side wing for controlling said locking means.

21. A car in combination with a side wing
50 pivotally connected therewith, means mounted on the car for swinging said wing into or out of operative position, a material carrying wing pivotally connected with the outer portion of said side wing to swing to-
55 ward or away therefrom, means actuated by the swinging of said side wing for moving said material carrying wing into or out of operative position, means for locking the latter wing in inoperative position, and
60 means actuated by movement of the side wing for controlling said locking means.

22. A car in combination with a side wing pivotally connected therewith, means mounted on the car for swinging said wing into
65 or out of operative position, a material carrying wing pivotally connected intermediately of the length thereof with the outer portion of said side wing, and braces connected with the car and with said material
70 carrying wing at opposite sides of the pivot thereof.

23. A car in combination with a side wing pivotally connected therewith, means mounted on the car for swinging said wing into
75 or out of operative position, a material carrying wing pivotally connected between its ends with the outer portion of said side wing and arranged to swing toward or away therefrom, a telescopic brace connected with
80 the car and with the rear end portion of said material carrying wing, and bracing means for the front end portion of the latter wing.

ROBERT E. BRESSLER.