



(51) International Patent Classification:

A61B 1/005 (2006.01) A61B 1/008 (2006.01)

A61B 1/00 (2006.01) A61B 1/01 (2006.01)

(21) International Application Number:

PCT/EP2020/064017

(22) International Filing Date:

20 May 2020 (20.05.2020)

(25) Filing Language:

English

(26) Publication Language:

English

(30) Priority Data:

62/850669 21 May 2019 (21.05.2019) US

(71) Applicant: KONINKLIJKE PHILIPS N.V. [NL/NL]; High Tech Campus 52, 5656 AG Eindhoven (NL).

(72) Inventors: CUSCUNA, Dino, Francesco; High Tech Campus 5, 5656 AE Eindhoven (NL). CHAN, Edward; High Tech Campus 5, 5656 AE Eindhoven (NL). CASWELL, John, Bench; High Tech Campus 5, 5656 AE Eindhoven (NL). BISHOP, Brian, Michael; High Tech Campus 5, 5656 AE Eindhoven (NL).

(74) Agent: PHILIPS INTELLECTUAL PROPERTY & STANDARDS; High Tech Campus 5, 5656 AE Eindhoven (NL).

(81) Designated States (unless otherwise indicated, for every kind of national protection available): AE, AG, AL, AM, AO, AT, AU, AZ, BA, BB, BG, BH, BN, BR, BW, BY, BZ, CA, CH, CL, CN, CO, CR, CU, CZ, DE, DJ, DK, DM, DO, DZ, EC, EE, EG, ES, FI, GB, GD, GE, GH, GM, GT, HN, HR, HU, ID, IL, IN, IR, IS, JO, JP, KE, KG, KH, KN, KP, KR, KW, KZ, LA, LC, LK, LR, LS, LU, LY, MA, MD, ME, MG, MK, MN, MW, MX, MY, MZ, NA, NG, NI, NO, NZ, OM, PA, PE, PG, PH, PL, PT, QA, RO, RS, RU, RW, SA,

SC, SD, SE, SG, SK, SL, ST, SV, SY, TH, TJ, TM, TN, TR, TT, TZ, UA, UG, US, UZ, VC, VN, WS, ZA, ZM, ZW.

(84) Designated States (unless otherwise indicated, for every kind of regional protection available):

ARIPO (BW, GH, GM, KE, LR, LS, MW, MZ, NA, RW, SD, SL, ST, SZ, TZ, UG, ZM, ZW), Eurasian (AM, AZ, BY, KG, KZ, RU, TJ, TM), European (AL, AT, BE, BG, CH, CY, CZ, DE, DK, EE, ES, FI, FR, GB, GR, HR, HU, IE, IS, IT, LT, LU, LV, MC, MK, MT, NL, NO, PL, PT, RO, RS, SE, SI, SK, SM, TR), OAPI (BF, BJ, CF, CG, CI, CM, GA, GN, GQ, GW, KM, ML, MR, NE, SN, TD, TG).

Declarations under Rule 4.17:

— as to applicant's entitlement to apply for and be granted a patent (Rule 4.17(ii))

Published:

— with international search report (Art. 21(3))

(54) Title: PULL-CABLE MANAGEMENT FOR STEERABLE CATHETER

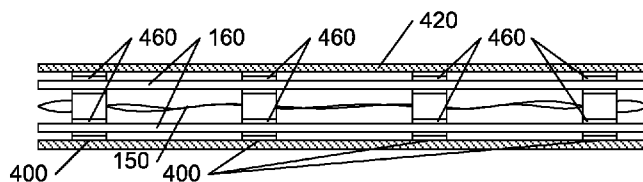

FIG. 5

(57) Abstract: A steerable catheter comprises a transducer that is situated at a flexible distal end, and is coupled to the handle of the catheter via an insertion tube. The flexible distal end is controlled by a plurality of articulation pull-cables that extend from an articulation control device in the handle to the far end of the distal end, such that when one articulation pull-cable is pulled, and the opposing articulation pull-cable is slackened, the flexible distal end bends in the direction of the tensioned articulation pull-cable. To minimize pull-resistance over time, while still providing insertion-tube flexibility, inserts having pull-cable lumens are situated in the insertion tube to isolate each articulation pull-cable from each other, and from other cables that couple the transducer to the handle.



PULL-CABLE MANAGEMENT FOR STEERABLE CATHETER

FIELD OF THE INVENTION

This invention relates to the field of medical instruments, and in particular to a method and system for managing articulation pull-cables in a steerable catheter or other steerable instruments, such as endoscopes, gastroscopes, and transesophageal
5 echocardiography (TEE) probes.

BACKGROUND OF THE INVENTION

Catheters are commonly used for situating elements within passages in a patient's body, to monitor particular biometrics, perform surgical procedures, administer medication,
10 and so on. To navigate through the passages, steerable catheters having an articulating distal end have been developed.

FIGs. 1A-1C illustrate an example prior-art steerable catheter 100. The catheter 100 comprises a handle 110, an insertion tube 120, a flexible distal end 130, and a transducer 170. The transducer 170 acquires imaging data via ultrasound. Other devices may be substituted
15 for transducer 170, these devices may receive biometrics of a patient and/or optical images of internal passages, or it may execute tasks such as making incisions, clearing blockages, administering medication, and so on. To perform these actions, the handle 110 is coupled to a medical-instrument controller (not shown) and is coupled to the transducer 170 via one or more transducer cables 150 within the insertion tube 120. In the example of the ultrasound
20 transducer 170 above, the steerable catheter 100 may be an ultrasound probe, such as a transesophageal echocardiography (TEE) ultrasound probe, a transvaginal ultrasound probe, for use with an ultrasound system.

FIG. 1B illustrates the catheter 100 in a 'neutral' state wherein the flexible distal end 130 is not bent or twisted. The handle 110 includes an articulation controller 115 that is
25 coupled to the flexible distal end 130 via articulation pull-cables 160a, 160b (collectively, articulation pull-cables 160) that extend through the insertion tube 120 to the flexible distal end 130.

As illustrated in cross-section 2A, these articulation pull-cables 160 are fixedly attached to a terminator 175 that is situated at the transducer-end of the flexible distal end 130, and can be selectively tensioned/pulled by the articulation controller 115.

As illustrated, the articulation pull-cables 160a, 160b are situated opposite each other at an outer perimeter area of the terminator 175. This enables two degrees of freedom for adjusting the orientation of the flexible distal end 130. In some embodiments, the flexible distal end 130 includes structural details that limit the bending of the flexible distal end 130 in the two opposite directions. When the upper cable 160b is pulled via the articulation controller 115, and the lower cable 160a is correspondingly slackened, via rotation 118 of the articulation controller 115, the tension causes the flexible distal end 130 to twist upwards, as illustrated in FIG. 1A. Reversing the rotation 119 on the articulation controller 115 causes the lower cable 160a to be pulled and the upper cable 160b to be slackened, causing the flexible distal end 130 to twist downward, as illustrated in FIG. 1C.

Although two articulation pull-cables 160a, 160b are illustrated, a steerable catheter may include a larger plurality of cables situated on the perimeter of the terminator 175 to provide additional degrees of freedom of movement. Typically, four articulation pull-cables are provided to provide horizontal and vertical bending of the flexible distal end 130.

In some embodiments, as illustrated in FIG. 3, pull-cable lumens 165 are provided through the flexible distal end 130 to provide a more uniform tension within the flexible distal end 130 as the articulation pull-cables 160 are tensioned/pulled.

For proper articulated steering, the flexible distal end 130 should be more flexible than the insertion tube 120, yet the insertion tube 120 must provide sufficient flexibility to minimize a patient's discomfort as the insertion tube 120 travels within the patient's internal vessels. Accordingly, a single lumen 190 is provided for routing the transducer cables 150 and articulation pull-cables 160, as illustrated in the cross-section of FIG. 2B, so that the flexibility of the insertion tube 120 may be determined primarily by the dimensions and composition of the material forming the cylindrical insertion tube 120. The single lumen 190 also facilitates the insertion/routing of the cables 150, 160 within the insertion tube 120. However, this structure-less lumen 190 introduces issues that affect the reliability and longevity of the steerable catheter 100, as detailed below.

SUMMARY OF THE INVENTION

An object of this invention is to provide a more robust catheter or similar elongated medical instrument device design by providing structure for cable routing within the insertion tube of a steerable catheter or (elongated) device without significantly affecting the flexibility of the insertion tube.

5 To better address one or more of these concerns, in an embodiment of this invention, the insertion tube may include a plurality of inserts that are spaced along the insertion tube from the handle to the distal end. Each insert of the plurality of inserts may include a plurality of lumens comprising one or more transducer-cable lumens and a plurality of pull-cable lumens, wherein the plurality of lumens isolate the transducer cable and each of the plurality
10 of articulation pull-cables from each other.

BRIEF DESCRIPTION OF THE DRAWINGS

The invention is explained in further detail, and by way of example, with reference to the accompanying drawings wherein:

15 FIGs. 1A-1C illustrate an example prior art steerable catheter.
FIGs. 2A-2B illustrate example cross-sections of the prior art steerable catheter.
FIG. 3 illustrates an example prior art flexible distal end of a steerable catheter.
FIG. 4 illustrates an example insert for placement within an insertion tube.
FIG. 5 illustrates a plurality of inserts in an insertion tube.
20 FIGs. 6 and 7 illustrate alternative insert structures.
FIG. 8 illustrates a string of components for insertion into an insertion tube.
FIG. 9 illustrates an alternative insert structure.

Throughout the drawings, the same reference numerals indicate similar or corresponding features or functions. The drawings are included for illustrative purposes and
25 are not intended to limit the scope of the invention.

DETAILED DESCRIPTION

In the following description, for purposes of explanation rather than limitation, specific details are set forth such as the particular architecture, interfaces, techniques, etc., in
30 order to provide a thorough understanding of the concepts of the invention. However, it will be apparent to those skilled in the art that the present invention may be practiced in other embodiments, which depart from these specific details. In like manner, the text of this description is directed to the example embodiments as illustrated in the figures, and is not intended to limit the claimed invention beyond the limits expressly included in the claims.

For purposes of simplicity and clarity, detailed descriptions of well-known devices, circuits, and methods are omitted so as not to obscure the description of the present invention with unnecessary detail.

It is understood that the implementation of the following-described inventions in a catheter used in blood vessels is merely exemplary. The scope of the invention encompasses any steerable devices, such as elongated medical devices, including catheters, which are intended to be inserted into bodily vessels, canals, passageways and cavities, and which have steerable distal portions for use in imaging, medical procedures, placement of implants, removal of implants and the like.

Non limiting examples of other such medical devices falling within the scope of the invention are endoscopes, gastroscopes, transvaginal ultrasound probes, and transesophageal echocardiography (TEE) ultrasound probes. In an embodiment including a TEE, transducer 170 is of course an ultrasound transducer. The inventions as described below for use in the exemplary catheters may be readily implemented in these other elongated medical devices as well, and thus enjoy similar benefits and improvements over the prior art arrangements.

As mentioned above, the prior art catheter is prone to premature failure due to the structure-less lumen 190 of the insertion tube 120, illustrated in FIG. 2B. After repeated usage, the cables 150, 160 often become entangled with each other, causing an increased resistance in the tensioning and slackening of the articulation pull-cables 160. This increased resistance can often lead to a premature failure of the catheter 100 due to an inability to pull or slacken one of the articulation pull-cables 160. This increase of resistance can be lessened by encasing each articulation pull-cable 160 in a protective sleeve that is sized to enable the articulation pull-cable 160 to be pulled and slackened, and sufficiently rigid to withstand deformation by the other cables. However, such a protective shield on each articulation pull-cable 160 would significantly affect the overall flexibility of the insertion tube 120.

FIG. 4 illustrates an example insert 400 that provides structure within an insertion tube 420. The example insert 400 includes a transducer lumen 450 through which one or more transducer cables 150 transit, and a plurality of pull-cable lumens 460, through which a plurality of steering cables 160 transit. As illustrated, the pull-cable lumen 460 is C-shaped, and forms an enclosed volume when situated within the insertion tube 420.

As in a conventional catheter as illustrated in FIG. 1, the transducer cables 150 are coupled to a transducer 170 at a flexible distal end 130 of the catheter, and to the handle 110 for coupling to a medical control device (not illustrated) in the handle 110 or external to the handle 110. The articulation pull-cables 160 are fixedly attached to a terminator 175 at the far

end of the flexible distal end 130, and coupled to an articulation control element 115 in the handle 110. Depending upon the structure of the control element 115, the articulation pull-cables 160 may be fixedly attached to the control element 115, or moveably attached to the control element 115, such as a pair of articulation pull-cables 160 comprising a
5 continuous cable on a perimeter of a wheel that is rotated by the control element 115, exerting tension on one articulation pull-cable of the pair and slackening the other articulation pull-cable. The insertion tube 120 is attached to the handle 110 and the flexible distal end 130.

Non limiting examples of the transducer 170 according to the present disclosure are
10 an electromechanical transducer, an electroacoustic transducer such as an ultrasonic (or ultrasound) transducer.

The lumens 450, 460 provide isolation of the articulation pull-cables 160 from the transducer cables 150, and from each other. The pull-cable lumens 460 are sized to enable free travel of the articulation pull-cables 160. In embodiments of this invention, the
15 articulation pull-cables 160 or the pull-cable lumen 460, or both, may be coated with a lubricous material that facilitates travel of the articulation pull-cable through the pull-cable lumen. In some embodiments, the insert comprises lubricous material to facilitate insertion of the insert into the insertion tube 420. In some embodiments, the insert comprises a high-temperature resilient material.

Although the insert 400 may extend the entire length of the insertion tube 420, such a
20 structure is likely to interfere with the flexibility of the insertion tube 420. Accordingly, in embodiments of this invention, a plurality of inserts 400 are situated along the length of the insertion tube, as illustrated in FIG. 5. To prevent displacement or rotation of each insert, the inserts 400 may be attached to the insertion tube 420 using heat staking, RF welding, or other
25 attachment techniques.

FIGs. 6 and 7 illustrate alternative structures for the insert 400. In FIG. 6, an
enclosing pull-cable lumen 460 is provided for each articulation pull-cable 160, to facilitate assembly. In this embodiment, the transducer cables 150, the articulation pull-cables 160, and the inserts 400 can be pre-assembled as a string of components that are subsequently
30 enclosed by the insertion tube 420, as detailed further below.

FIG. 7 illustrates an example embodiment wherein the transducer cables 150 are embedded in the insert 400. That is, each insert 400 is molded or otherwise formed around the transducer cables 150 such that the cables 150 are fixedly attached to each insert 400. In

this embodiment, closed transducer-cable lumens 450 are formed by the cables 150 as each insert is formed.

FIG. 8 illustrates an example string of components 800 comprising the transducer cables 150 embedded in each of a plurality of inserts 400. Also embedded in each insert 400 is a draw wire 850. The draw wire 850 may be used to pull the string 800 through the insertion tube 420 to create the assembly illustrated in FIG. 5.

If the inserts 400 include enclosing pull-cable lumens 460 as illustrated in FIG. 6, the articulation pull-cables 160 may be strung through the pull-cable lumens 460 of this string of components 800. Alternatively, if the inserts 400 comprise open pull-cable lumens 460 as illustrated in FIG. 7, the articulation pull-cables 160 may be laid into each pull-cable lumen 460 of the inserts 400 as a string of components similar to the string of components 800 are drawn into the insertion tube 420.

FIG. 9 illustrates an example insert that is structured to capture each articulation pull-cable 160 as it is laid into the pull-cable lumen 460. As illustrated, the insert 400 includes a trough that has an opening 960 that is slightly smaller than the diameter of the articulation pull-cable 160. In this embodiment, the insert 400 comprises a resilient material that enables the larger articulation pull-cable 160 to be inserted through the smaller opening 960. Once inserted, the articulation pull-cable 160 is captured by the pull-cable lumen 460 within the pliable material as it returns to its original state of having a smaller opening 960 than the diameter of the articulation pull-cable 160.

FIG. 10 illustrates an example flow diagram 1000 for assembling a steering catheter with articulation pull-cable support within the insertion tube. One of skill in the art will recognize that the illustrated order of steps is provided for ease of understanding, and the steps may be performed in different order, and/or some steps may be performed concurrently. One of skill in the art will also recognize that, with the exception of installing the inserts with articulation pull-cable and transducer cable lumens in the insertion tube, the assembly of the steering catheter is consistent with known prior art techniques that do not require detailed descriptions in this specification.

At 1010, a plurality of inserts having pull-cable lumens are obtained. These may be pre-formed inserts, or created by extrusion or molding about a draw wire and/or transducer cables. At 1015, a draw wire is attached to each insert, and at 1020, one or more transducer cables are routed through each insert. As noted above, steps 1010, 1015, and 1020 may be performed concurrently, as when the inserts are coextruded over the draw wire and the transducer cable(s).

At 1025, the articulation pull-cables are routed through the pull-cable lumens of each insert. If the pull-cable lumens are troughs, the articulation pull-cables may be temporarily held in place until the insert is about to be drawn into the insertion tube.

At 1030, the draw wire is passed through the insertion tube, and at 1035, the draw
5 wire is drawn to draw the assembly of inserts, transducer cable(s), and articulation pull-cables into the insertion tube. In alternative embodiments, the insertion tube may be extruded or otherwise formed over the assembly, eliminating the need for a draw wire.

At 1040, the inserts are attached to the insertion tube. This attachment is optional; if
10 the inserts are sufficiently held in place by elastic pressure from the walls of the insertion tube, or by the formation of the insertion tube upon the assembly, further attachment may be unnecessary. As noted above, if attachment is necessary, heat staking, RF welding, or other attachment techniques may be used. In some embodiments, the insertion tube may be a heat-shrink material that facilitates placement of the assembly in the insertion tube, and heat is subsequently applied to attach the insertion tube to each insert.

At 1045, the transducer cables are attached at each end to couple the transducer to the
15 handle, and at 1050, the articulation pull-cables are attached at each end of the assembly so as to couple the flexible distal end to an articulation control in the handle.

Final assembly of the catheter is performed by coupling the insertion tube to the
20 handle and the flexible distal end, at 1055.

While the invention has been illustrated and described in detail in the drawings and
25 foregoing description, such illustration and description are to be considered illustrative or exemplary and not restrictive; the invention is not limited to the disclosed embodiments.

For example, it is possible to operate the invention in an embodiment wherein a
30 continuous insert is coextruded over the transducer cables, then selectively etched or otherwise reduced in diameter to create a plurality of full-size (unetched) inserts between these thinner (etched) segments. For example, the material between the pull-cable lumens
460 along the perimeter of the continuously extruded insert can be selectively removed, leaving only the transducer cables embedded in the residual material between the unmodified inserts.

Other variations to the disclosed embodiments can be understood and effected
35 by those skilled in the art in practicing the claimed invention, from a study of the drawings, the disclosure, and the appended claims. In the claims, the word "comprising" does not exclude other elements or steps, and the indefinite article "a" or "an" does not exclude a plurality. The mere fact that certain measures are recited in mutually different dependent

claims does not indicate that a combination of these measures cannot be used to advantage. Reference signs in the claims, if any, should not be construed as limiting the scope of the claims.

CLAIMS:

1. An elongated medical device comprising:

a handle (110) comprising a steering element (115);

a flexible distal end (130);

an insertion tube (120) disposed between the handle and the distal end;

wherein the distal end comprises a transducer (170);

at least one transducer cable (150), wherein the at least one transducer cable couples the handle to the transducer, via the insertion tube; and

a plurality of articulation pull-cables (160), wherein the plurality of articulation pull-cables couples the steering element to the distal end, via the insertion tube;

wherein the plurality of articulation pull-cables are controlled at the steering element so as to articulate the distal end in a desired direction;

wherein the insertion tube includes a plurality of inserts (400);

wherein the plurality of inserts are spaced along the insertion tube from the handle to the distal end;

wherein each insert of the plurality of inserts includes a plurality of lumens (450, 460);

wherein the plurality of lumens comprise:

one or more transducer-cable lumens (450) through which the at least one transducer cable extends, and

a plurality of pull-cable lumens (460) through which the plurality of articulation pull-cables extends; and

wherein the plurality of lumens isolate the transducer cable and each of the plurality of articulation pull-cables from each other.

2. The device of claim 1, wherein a flexibility of the flexible distal end is substantially greater than a flexibility of the insertion tube.

3. The device of claims 1 or 2,

wherein each of the one or more transducer-cable lumens is situated in a center area of each insert, and

wherein each of the plurality of pull-cable lumens is situated along a perimeter area of each insert.

4. The device of any of the claims 1 to 3, wherein the pull-cable lumens comprise C-shaped lumens at a perimeter of the insert.

5. The device of claim 4, wherein an opening (960) in the C-shaped lumen is smaller than a diameter of the articulation pull-cable.

6. The device of any of the claims 1 to 5, wherein the one or more transducer-cable lumens are closed and fixedly attached to the one or more transducer cables.

7. The device of any of the claims 1 to 6, wherein each of the pull-cable lumens are sized to allow each articulation pull-cable to freely travel through the pull-cable lumens.

8. The device of any of the claims 1 to 7, wherein each of the plurality of pull-cable lumens includes a lubricous material that facilitates travel of the articulation pull-cable through the pull-cable lumen.

9. The device of any of the claims 1 to 8, wherein each insert comprises a high-temperature resilient material.

10. The device of any of the claims 1 to 9, wherein each insert is secured to the insertion tube.

11. The device of any of the claims 1 to 10, wherein the at least one transducer cable, the plurality of articulation pull-cables, and the plurality of inserts are arranged as a string of components (800) that is inserted into the insertion tube.

12. The device of any of claims 1 to 11, comprising a draw wire (850) that is fixedly attached to each of the inserts and enables the plurality of inserts to be drawn into the insertion tube.

13. An assembly of components (800) comprising:
- a plurality of inserts (400) that are structured to be inserted in an insertion tube (120) of an elongated medical device;
 - one or more transducer cables (150) that traverse each of the plurality of inserts; and
 - a draw wire (850) that is fixedly attached to the plurality of inserts;
- wherein each of the plurality of inserts includes a plurality of pull-cable lumens (460) that enable a plurality of articulation pull-cables (160) to freely travel through each of the plurality of inserts.
14. The assembly of claim 13, further comprising the plurality of articulation pull-cables.
15. The assembly of claims 13 or 14,
- wherein each insert comprises a resilient material, and each pull-cable lumen is C-shaped,
 - wherein each pull-cable lumen comprises an opening (960) in the C-shape,
 - wherein the opening (960) is narrower than a diameter of the articulation pull cables.
16. The assembly of any of the claims 13 to 15, wherein each of the one or more transducer cables are fixedly attached to each insert.
17. A method of assembling an elongated medical device comprising:
- providing (10) a handle (110), an insertion tube (120), a flexible distal end (130), and a transducer (170);
 - creating (15-20) an assembly of components comprising a plurality of inserts (400), one or more transducer cables (150) that traverse each of the plurality of inserts; and a draw wire (850) that is fixedly attached to the plurality of inserts;
- wherein each of the plurality of inserts includes a plurality of pull-cable lumens (460);
- threading (25) a plurality of articulation pull-cables (160) through each of the plurality of inserts via the plurality of pull-cable lumens in each insert;
 - passing (30) the draw wire through the insertion tube;
 - drawing (35) the draw wire to draw the assembly of components into the insertion tube;

attaching (50) the plurality articulation pull-cables to an articulation control at the handle, and to a terminator at the flexible distal end;

coupling (45) the one or more transducer cables to the handle and to the transducer at a far end of the flexible distal end; and

coupling (55) the insertion tube to the handle and to the flexible distal end.

18. The method of claim 17, comprising attaching (40) the plurality of inserts to the insertion tube.

19. The method of claim 17 or 18, wherein the inserts are resilient and each pull-cable lumen is C-shaped, with an opening (960) that is narrower than a diameter of the articulation pull-cables, and the method includes pressing the articulation pull-cables through the opening using the resilience of the insert to expand the opening.

20. The method of any of the claims 17 to 19, wherein the inserts comprise a lubricious material that facilitates the drawing of the assembly of components into the insertion tube.

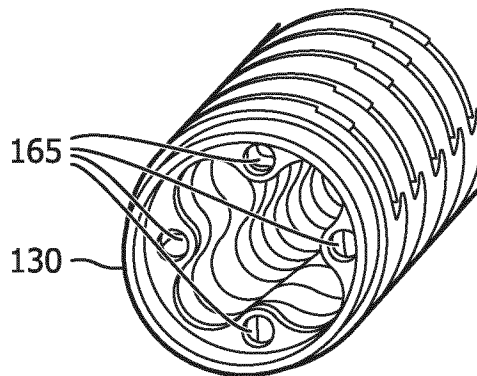
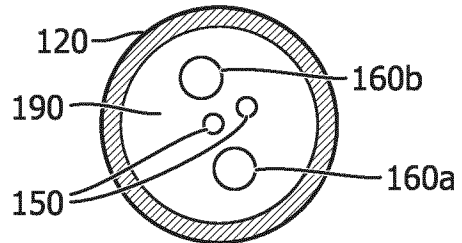
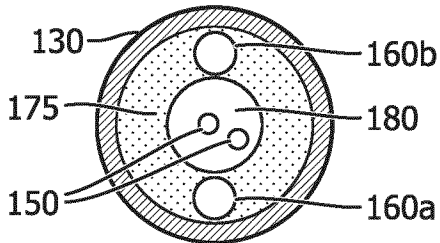
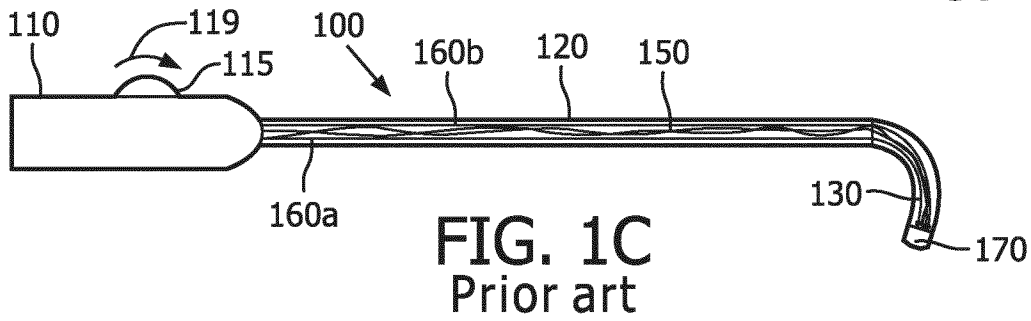
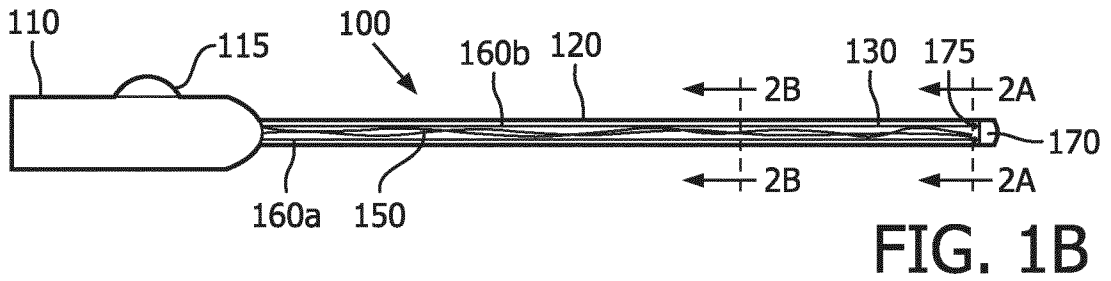
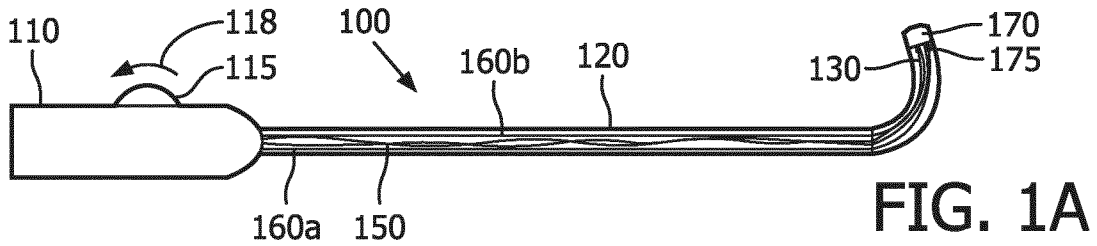

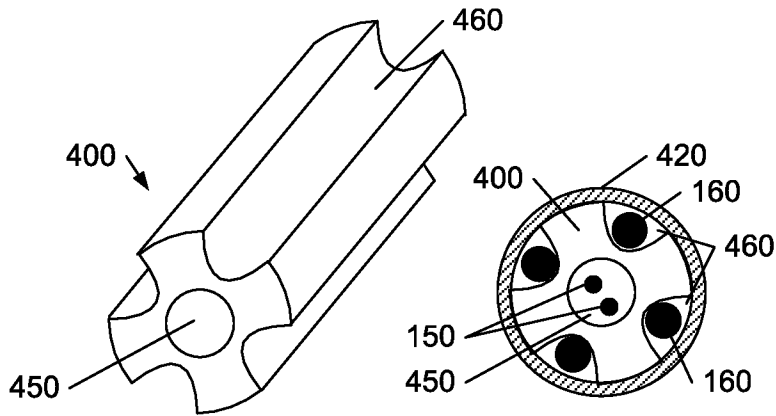

FIG. 4

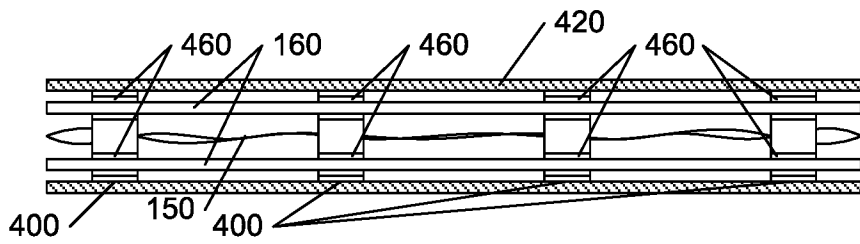

FIG. 5

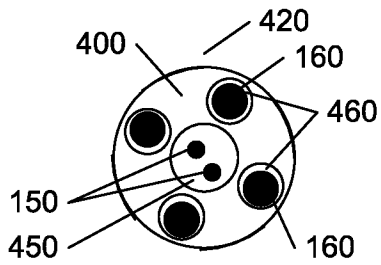

FIG. 6

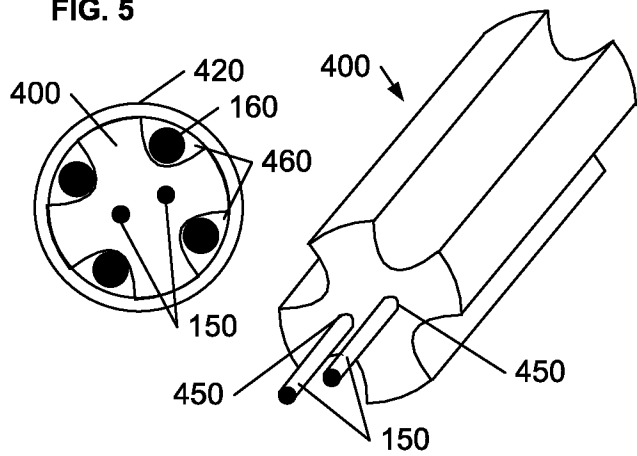

FIG. 7

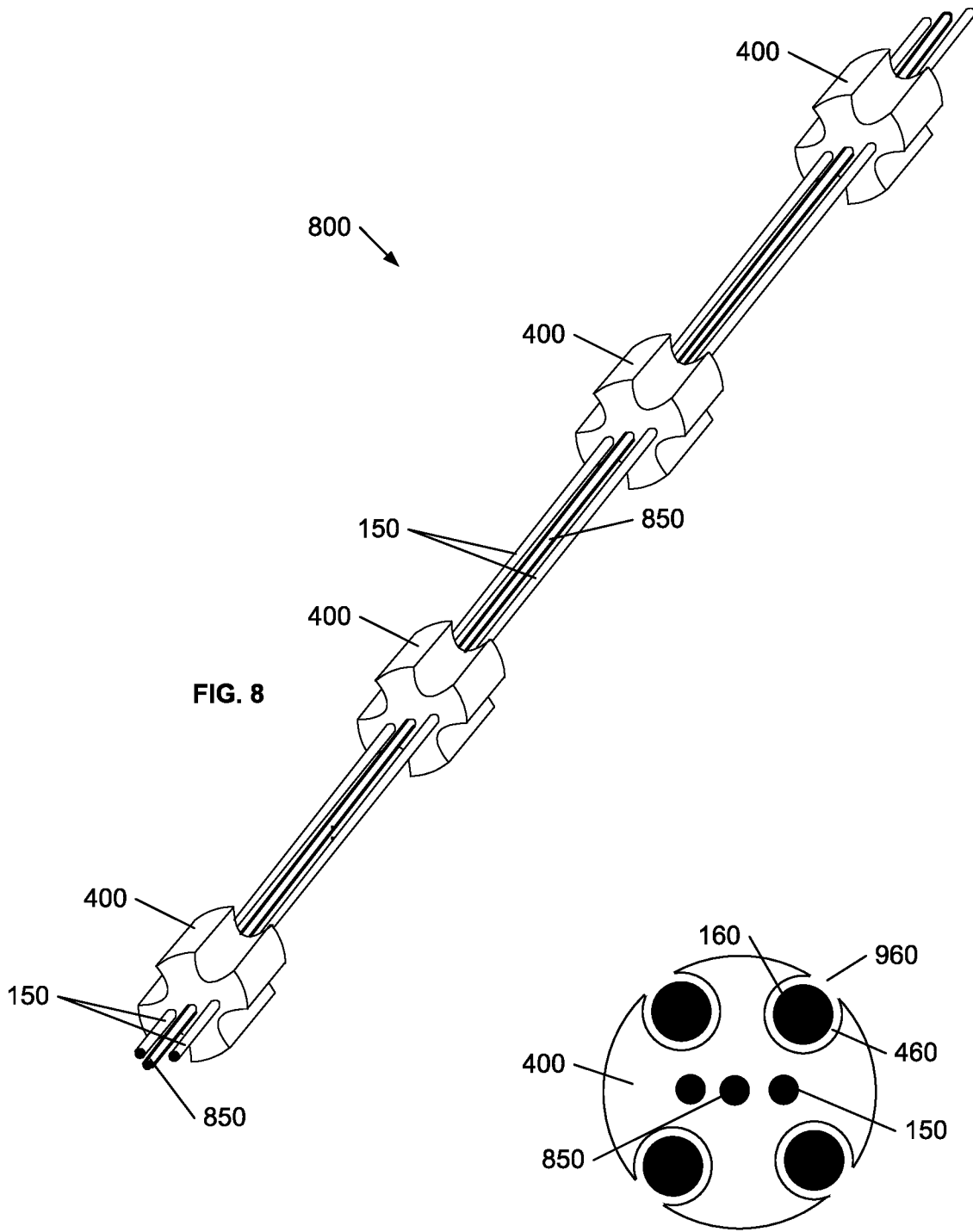

FIG. 9

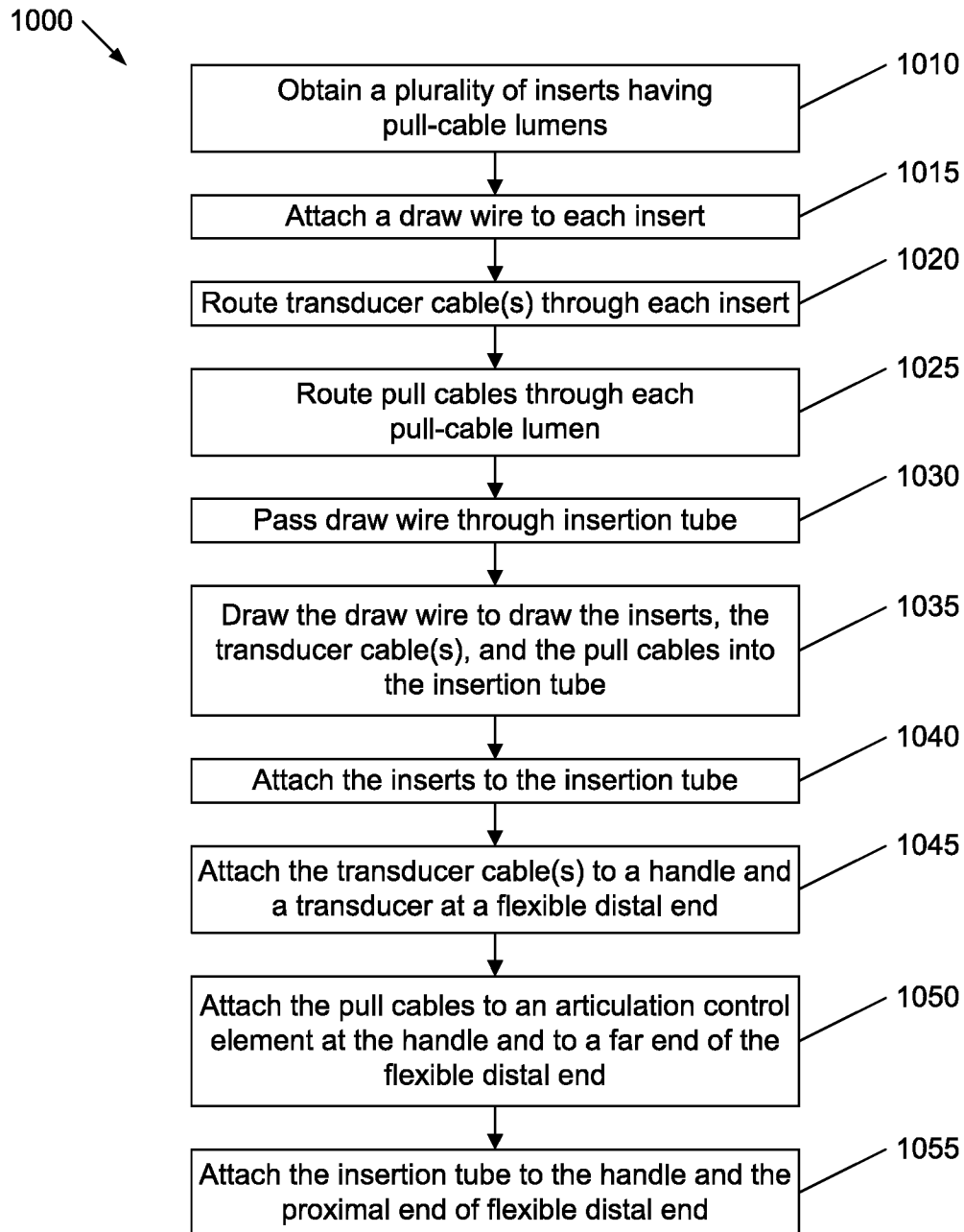

FIG. 10

INTERNATIONAL SEARCH REPORT

International application No
PCT/EP2020/064017

A. CLASSIFICATION OF SUBJECT MATTER
 INV. A61B1/005 A61B1/00
 ADD. A61B1/008 A61B1/01

According to International Patent Classification (IPC) or to both national classification and IPC

B. FIELDS SEARCHED

Minimum documentation searched (classification system followed by classification symbols)
 A61B A61M

Documentation searched other than minimum documentation to the extent that such documents are included in the fields searched

Electronic data base consulted during the international search (name of data base and, where practicable, search terms used)
 EPO-Internal, WPI Data

C. DOCUMENTS CONSIDERED TO BE RELEVANT

Category*	Citation of document, with indication, where appropriate, of the relevant passages	Relevant to claim No.
X	US 2015/094594 A1 (HARHEN EDWARD PAUL [US] ET AL) 2 April 2015 (2015-04-02)	1-3,7,10,11
Y	paragraphs [0020] - [0050]; figures 1-8	6,12-20
X	WO 2008/070556 A1 (BOSTON SCIENT SCIMED INC [US]) 12 June 2008 (2008-06-12)	1,2,8-11
Y	paragraphs [0137] - [0182], [0408], [0428]; figures 2, 7A-7E, 109, 120A	5,15,19,20
X	US 7 235 089 B1 (MCGUCKIN JR JAMES F [US]) 26 June 2007 (2007-06-26)	1,3,4,7,10,11
Y	column 12, line 1 - column 16, line 50; figures 1A - 14	5,15
X	EP 0 782 836 A1 (HEWLETT PACKARD CO [US]) 9 July 1997 (1997-07-09)	1,3,4,7,10,11
	column 3, line 25 - column 6, line 17; figures 2A-6	
	----- -/--	

Further documents are listed in the continuation of Box C.

See patent family annex.

* Special categories of cited documents :

"A" document defining the general state of the art which is not considered to be of particular relevance

"E" earlier application or patent but published on or after the international filing date

"L" document which may throw doubts on priority claim(s) or which is cited to establish the publication date of another citation or other special reason (as specified)

"O" document referring to an oral disclosure, use, exhibition or other means

"P" document published prior to the international filing date but later than the priority date claimed

"T" later document published after the international filing date or priority date and not in conflict with the application but cited to understand the principle or theory underlying the invention

"X" document of particular relevance; the claimed invention cannot be considered novel or cannot be considered to involve an inventive step when the document is taken alone

"Y" document of particular relevance; the claimed invention cannot be considered to involve an inventive step when the document is combined with one or more other such documents, such combination being obvious to a person skilled in the art

"&" document member of the same patent family

Date of the actual completion of the international search	Date of mailing of the international search report
5 August 2020	14/08/2020

Name and mailing address of the ISA/ European Patent Office, P.B. 5818 Patentlaan 2 NL - 2280 HV Rijswijk Tel. (+31-70) 340-2040, Fax: (+31-70) 340-3016	Authorized officer Mäki-Mantila, M
--	---

INTERNATIONAL SEARCH REPORT

International application No
PCT/EP2020/064017

C(Continuation). DOCUMENTS CONSIDERED TO BE RELEVANT		
Category*	Citation of document, with indication, where appropriate, of the relevant passages	Relevant to claim No.
X	US 2013/096572 A1 (DONHOWE CAITLIN Q [US] ET AL) 18 April 2013 (2013-04-18) paragraphs [0016] - [0030]; figures 1,2 -----	1,2,7
Y	EP 1 737 335 A2 (BOSTON SCIENT LTD [BB]) 3 January 2007 (2007-01-03) paragraph [0064]; figure 22 -----	6,16
Y	EP 2 074 928 A2 (OLYMPUS CORP [JP]) 1 July 2009 (2009-07-01) paragraphs [0104] - [0110]; figures 25-27 -----	12-20
Y	EP 1 072 280 A2 (MEDTRONIC INC [US]) 31 January 2001 (2001-01-31) paragraph [0029]; figure 1B -----	12-20

INTERNATIONAL SEARCH REPORT

Information on patent family members

International application No

PCT/EP2020/064017

Patent document cited in search report	Publication date	Patent family member(s)	Publication date
US 2015094594	A1	02-04-2015	CA 2644967 A1 13-09-2007
			CN 101437439 A 20-05-2009
			CN 102090903 A 15-06-2011
			EP 1996064 A2 03-12-2008
			JP 2009528910 A 13-08-2009
			US 2007239022 A1 11-10-2007
			US 2015094594 A1 02-04-2015
			WO 2007103872 A2 13-09-2007

WO 2008070556	A1	12-06-2008	AU 2007329516 A1 12-06-2008
			CA 2670800 A1 12-06-2008
			CA 3018269 A1 12-06-2008
			CN 101594816 A 02-12-2009
			CN 106943164 A 14-07-2017
			EP 2395902 A1 21-12-2011
			EP 3120750 A1 25-01-2017
			ES 2596516 T3 10-01-2017
			JP 5498794 B2 21-05-2014
			JP 6085530 B2 22-02-2017
			JP 6139630 B2 31-05-2017
			JP 6538104 B2 03-07-2019
			JP 2010511440 A 15-04-2010
			JP 2013223751 A 31-10-2013
			JP 2016039918 A 24-03-2016
			JP 2017164519 A 21-09-2017
			US 2008188868 A1 07-08-2008
			US 2008188869 A1 07-08-2008
			US 2008188871 A1 07-08-2008
			US 2008188890 A1 07-08-2008
			US 2008221391 A1 11-09-2008
			US 2008243176 A1 02-10-2008
			US 2012004502 A1 05-01-2012
			US 2015238180 A1 27-08-2015
			US 2016089007 A1 31-03-2016
			US 2016228113 A1 11-08-2016
			US 2017007345 A1 12-01-2017
			US 2019231466 A1 01-08-2019
			US 2020163733 A1 28-05-2020
			WO 2008070556 A1 12-06-2008

US 7235089	B1	26-06-2007	US 7235089 B1 26-06-2007
			US 2007213743 A1 13-09-2007

EP 0782836	A1	09-07-1997	EP 0782836 A1 09-07-1997
			JP H09182737 A 15-07-1997
			US 5749828 A 12-05-1998

US 2013096572	A1	18-04-2013	US 2013096572 A1 18-04-2013
			US 2016302873 A1 20-10-2016
			US 2020146757 A1 14-05-2020

EP 1737335	A2	03-01-2007	AU 2005228956 A1 13-10-2005
			CA 2558796 A1 13-10-2005
			EP 1737335 A2 03-01-2007
			ES 2409160 T3 25-06-2013
			ES 2552252 T3 26-11-2015
			JP 4764417 B2 07-09-2011
			JP 5430528 B2 05-03-2014

INTERNATIONAL SEARCH REPORT

Information on patent family members

International application No

PCT/EP2020/064017

Patent document cited in search report	Publication date	Patent family member(s)	Publication date
		JP 5864496 B2	17-02-2016
		JP 2007530155 A	01-11-2007
		JP 2011050748 A	17-03-2011
		JP 2014023945 A	06-02-2014
		US 2005272975 A1	08-12-2005
		US 2011213300 A1	01-09-2011
		US 2012209073 A1	16-08-2012
		US 2014066706 A1	06-03-2014
		US 2017231475 A1	17-08-2017
		WO 2005094665 A2	13-10-2005
EP 2074928	A2	01-07-2009	EP 2074928 A2
			US 2009171150 A1
			02-07-2009
EP 1072280	A2	31-01-2001	AT 200738 T
			AU 1429492 A
			CA 2101168 A1
			DE 69231804 T2
			DE 69233585 T2
			EP 0571531 A1
			EP 1072280 A2
			JP 3394535 B2
			JP H06505188 A
			US 5231989 A
			US 5345937 A
			WO 9214506 A1
			03-09-1992