

(12) INTERNATIONAL APPLICATION PUBLISHED UNDER THE PATENT COOPERATION TREATY (PCT)

(19) World Intellectual Property Organization  
International Bureau



(43) International Publication Date  
7 November 2002 (07.11.2002)

PCT

(10) International Publication Number  
**WO 02/089421 A2**

- (51) International Patent Classification<sup>7</sup>: **H04L 12/46**
- (21) International Application Number: PCT/EP02/04286
- (22) International Filing Date: 18 April 2002 (18.04.2002)
- (25) Filing Language: English
- (26) Publication Language: English
- (30) Priority Data:  
01250155.7 2 May 2001 (02.05.2001) EP
- (71) Applicant (for all designated States except US): **THOMSON LICENSING S.A.** [FR/FR]; 46, quai A. le Gallo, F-92100 Boulogne-Billancourt (FR).
- (72) Inventors; and
- (75) Inventors/Applicants (for US only): **SCHWEIDLER, Siegfried** [DE/DE]; Suedfeld 10, 30989 Gehrden (DE). **HAUPT, Dieter** [DE/DE]; Steinkuhler Garten 2, 31832 Springe (DE). **GAEDKE, Klaus** [DE/DE]; Schaumannweg 22, 30659 Hannover (DE). **BORSUM, Malte** [DE/DE]; Kniestr. 6, 30167 Hannover (DE). **SCHÜTZE, Herbert** [DE/DE]; Ringweg 2, 29227 Celle (DE).
- (74) Agent: **SCHÄFERJOHANN, Volker**; DEUTSCHE THOMSON-BRANDT GMBH, European Patent Operations, Karl-Wiechert-Allee 74, 30625 Hannover (DE).
- (81) Designated States (national): AE, AG, AL, AM, AT, AU, AZ, BA, BB, BG, BR, BY, BZ, CA, CH, CN, CO, CR, CU, CZ, DE, DK, DM, DZ, EC, EE, ES, FI, GB, GD, GE, GH, GM, HR, HU, ID, IL, IN, IS, JP, KE, KG, KP, KR, KZ, LC, LK, LR, LS, LT, LU, LV, MA, MD, MG, MK, MN, MW, MX, MZ, NO, NZ, OM, PH, PL, PT, RO, RU, SD, SE, SG, SI, SK, SL, TJ, TM, TN, TR, TT, TZ, UA, UG, US, UZ, VN, YU, ZA, ZM, ZW.
- (84) Designated States (regional): ARIPO patent (GH, GM, KE, LS, MW, MZ, SD, SL, SZ, TZ, UG, ZM, ZW), Eurasian patent (AM, AZ, BY, KG, KZ, MD, RU, TJ, TM), European patent (AT, BE, CH, CY, DE, DK, ES, FI, FR, GB, GR, IE, IT, LU, MC, NL, PT, SE, TR), OAPI patent (BF, BJ, CF, CG, CI, CM, GA, GN, GQ, GW, ML, MR, NE, SN, TD, TG).

**Published:**  
— without international search report and to be republished upon receipt of that report

For two-letter codes and other abbreviations, refer to the "Guidance Notes on Codes and Abbreviations" appearing at the beginning of each regular issue of the PCT Gazette.

(54) Title: INTERFACE CIRCUIT

Start	Req-type	Address	Data	Stop
-------	----------	---------	------	------

(57) Abstract: The invention deals with a wireless extension of the IEEE 1394 bus. Considered is a scenario where two clusters of 1394 devices are linked to each other by means of a wireless bridge (9). The devices of one cluster shall communicate with devices of the other cluster without being bridge-aware. The wireless bridge, however, provides for a bus reset isolation. This causes a problem each time a bus reset occurs in one of the clusters. To solve this problem it is proposed to implement a buffer memory (22) for self-identification packets in the 1394 interfaces (11) of both boxes of said wireless bridge (9). In particular these buffer memories (22) shall be implemented in the physical layer section (21) of the 1394 interfaces (11). With these buffer memories the self-identification packets of the bus stations in the other cluster can be collected and they can easily be read out during the self-configuration phase of the network after a bus reset when the bus grant is assigned to the box of the wireless bridge that is also connected to the bus where the bus reset has occurred. The physical layer section of the 1394 interface transmits artificial self-identification packets for all bus stations of the other cluster so that data communication can continue without long delays.



WO 02/089421 A2

## Interface circuit

The invention relates to an interface for connecting a device to a communication bus which device has a bridge portal function for a bridge between a first communication bus and a second communication bus.

### Background

In the field of home systems the IEEE 1394 bus has become an important communication system with asynchronous and isochronous transport capability. The IEEE 1394 serial bus already provides an internationally standardized and very widely accepted bus for data exchange between terminals from both, the consumer electronics field and the computer industry. The precise designation of the aforementioned standard is: IEEE Standard for high performance serial bus, (IEEE) STD 1394-1995, IEEE New York, August 1996. In 2000 an improved version has been finalised with the reference IEEE 1394-2000.

20

The IEEE 1394 bus is a wired bus and it is specified that a maximum of 63 stations can participate in the communication over the bus lines. The 63 stations can be distributed in a flat or house. The maximum distance between two stations is 4.5 m. However, there are also solutions existing that extend the distance.

A problem with all wired bus systems is that the bus cable needs to be installed in every room where a bus station shall be located. This problematic gave rise to the wish of a wireless extension of the IEEE 1394 standard. A standalone device or a cluster of devices shall communicate with a first cluster by means of a wireless link.

In the meantime there are wireless protocols existing that can be used for the wireless link. The document 'Broadband Radio Access Networks (BRAN); Hiperlan Type 2; Packet based convergence layer; Part 3: IEEE 1394 Service Specific Convergence Sublayer (SSCS)' defines a sublayer emulating

the IEEE 1394 link layer over a ETSI BRAN Hiperlan/2 wireless network. As such, it may be present in bridge devices between wired 1394 busses, or in standalone wireless devices. When two busses are connected through a bridge, these two busses are still considered distinctly from the point of view of the IEEE 1394 standard. Moreover, since the sublayer has to be present in a standalone device, standard 1394 devices first have to be modified in order to be linked to a network through a wireless link.

10

The interconnection of the different busses (with different bus\_IDs) involves a IEEE 1394 bridge, which is currently under definition by the IEEE P1394.1 working group. Because of the use of different bus\_IDs, an application operating on bridges shall be bridge aware.

15

The box that connects the 1394 bus cable of a cluster to the wireless bridge needs to have a standard conform interface but on the other hand it needs to have some additional functionality which concerns the self configuration phase of the network. The 1394 bus has live insertion capability and each time a device is added or removed from the bus a bus reset is performed. After a bus reset each bus node sends a self-id packet to the bus, with which all other stations on the bus become aware of how many stations are present on the bus. The ID-number is a 6 bit number so that 64 devices can be distinguished. There is a specific process defined in the 1394 standard with which the ID-numbers are assigned to the stations. This will be described in more detail later on.

25  
30

If all the stations in the network shall be configured as belonging to one 1394 bus, the self-configuration phase must be performed in coordinated fashion in both clusters with the bridge circuit in-between.

35

The devices of the second cluster are not aware that they are connected via a wireless link to the network. To achieve transparent operation, it is necessary that the wireless

converters shall generate Self-ID packets that are reflecting the topology on both busses.

#### Invention

5 According to IEEE 1394 standard the generation of self-ID packets after a bus reset is performed in the physical layer section of the 1394 interface circuit. According to the invention the interfaces connecting the boxes for the wireless link shall have an enhanced 1394 interface in each  
10 case. They shall include a buffer memory in which the self-ID packets of the stations not belonging to the same cluster are stored. This buffer memory shall be part of the physical layer circuit section of the interface. This has the reason that after a bus reset communication shall be commenced as  
15 early as possible. With the implementation of the buffer in the physical layer section it is assured that there is the slightest delay between bus grant and self-ID packet transmission. The buffer memory that is used to buffer application data can therefore be smaller.

20

Further improvements of the interface circuit according to the invention are possible by virtue of the measures evinced in the dependent claims. During self-ID packet collection the buffer memory is addressed by means of a node counter  
25 and a data word counter in order to store the data words of the self-identification packets. As the self-ID packets are received in ascending order, they can be written in memory in the same order and it is not necessary to implement a complex address management logic.

30

A number of specific control registers can be used to control the operation of the node counter and data word counter such as incrementing, presetting and resetting a counter.

35

Further registers can be implemented as a pointer to a start and end value for a specific range in the buffer memory, such as the range where the box shall just listen to the received self-ID packets or the range where the box needs to

send self-ID packets to the bus. This facilitates address generation during the self-configuration phase.

It is also advantageous that the interface circuit comprises  
5 means for calculating an offset value for the buffer memory  
addressing each time after a bus reset wherein the offset  
value is calculated as the difference of the number of  
received self-ID packets from the communication bus on the  
other side of the bridge plus 1 and the start or end address  
10 in one of the above mentioned further registers. This allows  
for a direct generation of the self-ID packets when after a  
first bus reset the self-configuration phase of the network  
had been finished but due to a second bus reset phase some  
modification is required. Here, the data communication  
15 between stations that were present already before the second  
bus reset can be maintained very fast.

#### Drawings

20 Exemplary embodiments of the invention are illustrated in  
the drawings and are explained in more detail in the  
description below. In the figures:  
Figure 1 shows two 1394 clusters connected to each other  
via a wireless bridge;  
25 Figure 2 shows a block diagram of the interface circuit  
according to the invention;  
Figure 3 shows the format of a self-ID packet;  
Figure 4 shows the format of a write request to a register  
in the interface circuit;  
30 Figure 5 shows a block diagram for addressing the buffer  
memory for storing self-ID packets in the self-  
configuration phase;  
Figure 6 shows a first example of a buffer memory  
configuration according to the invention, and  
35 Figure 7 shows a second example of a buffer memory  
configuration according to the invention.

#### Exemplary embodiments of the invention

Figure 1 shows two 1394 busses with 1394 bus stations and a wireless bridge in-between. The first 1394 bus has assigned reference number 7. A first and second 1394 device is shown with reference numbers 1 and 2. Such a device can be a consumer electronics device such as TV set, VCR, Camcorder, Set Top Box, DVD player, etc. or a computer device like PC, Notebook, etc. Each of these devices is a standard conform 1394 device and has a corresponding 1394 interface 10.

10

With reference number 3 a first transceiver box for the wireless link 9 is denoted. This box also needs to have a 1394 interface because it is also connected to the 1394 bus lines 7. The corresponding interface has got reference number 11 in Fig. 1. This indicates already that it is not the same 1394 interface as that of devices 1 and 2. 1394 interface 11 has additional functionality involving the invention. Transceiver box 3 further has another interface 12 for wireless transmission. There are wireless protocols already existing supporting high speed communication. As an example the Hiperlan system is mentioned. The document 'Broadband Radio Access Networks (BRAN); Hiperlan Type 2; Packet based convergence layer; Part 3: IEEE 1394 Service Specific Convergence Sublayer (SSCS)' defines a sublayer emulating the IEEE 1394 link layer over a ETSI BRAN Hiperlan/2 wireless network. Other examples of wireless communication protocols for the wireless link are the IEEE 802.11 system and the Bluetooth system.

15

20

25

30

35

There is another cluster of 1394 devices shown in Fig. 1 having its own 1394 bus 8. Again, two 1394 devices 4 and 5 are depicted having standard 1394 interfaces 10. A second box 6 for the wireless bridge 9 is connected to the bus 8 as well. For the conception of the invention it is required that the total amount of bus stations in both clusters together inclusive wireless transceiver boxes 3 and 6 is less than or equal to 63. This is because with the wireless bridge 9 both clusters are merged together and data communication between devices from different clusters is

from the point of view of the 1394 devices by no means different than for communication between devices in one cluster. The maximum allowed number of bus nodes in a 1394 cluster is however 63. It is defined that the bus where a  
5 transceiver box of a wireless bridge has become the root device will be the remote bus. If in both busses a transceiver box of a wireless bridge has become the root device, a decision has to be made for example by game of dice.

10

A scenario with only one 1394 device in the remote cluster is described in the European Patent Application 00402901.3. A scenario with more than one 1394 device in the remote cluster is described in the European Patent Application  
15 01400826.2.

Fig. 2 shows the principal structure of a 1394 interface 10. The 1394 interface is subdivided in two parts a physical layer section 21 and a data link layer section 20. Both can  
20 be integrated in one single chip or two distinct chips. In principle it would also be possible that the data link layer section is implemented in software running on a powerful micro controller. Also the modified 1394 interface 11 has the same principle structure. The modification concerns a  
25 specific buffer memory 22 in the physical layer section and its management that will be explained later on.

To understand the modification of the physical layer chip it is helpful to first explain what happens in case of a bus  
30 reset. A bus reset is performed each time a 1394 device is plugged off (disconnected) from or plugged in (connected) to the bus. The 1394 bus standard provides full live insertion capability. This means that a device can be removed from or inserted in the bus lines without switching off the network.  
35 An insertion or removal of a bus station is accompanied by a specific voltage change on the bus lines that is detected by electronic means providing the bus reset. After a bus reset a self-configuration phase follows for the network. During the self configuration phase each bus station sends it self-

ID packet to the bus to inform every other user in the network that it is existing.

A self-ID packet has the format of that in Fig. 3. It  
5 consists of 64 bits where the last 32 bits are the inverse  
of the first 32 bits. Of course all bits of the self-ID  
packets are explained in the 1394 standard itself. Some of  
them will be expressively explained here. At the beginning  
of a self-ID packet there is the physical ID-number of the  
10 bus station. This field has a length of 6 bits corresponding  
to the numbers 0 ... 63. At the end of the self-ID packets  
there are 2-bit fields for the ports P0 to P2 of a bus  
station. With the two bits it can be notified not only the  
existence of the port in the station but also whether the  
15 port is active and connected to a parent or child in the bus  
topology. According to the IEEE1394 bus standard a bus  
station can be equipped with up to 16 ports. If a station  
has more than 3 ports their status will be reported in a  
second or third self-ID packet. The last bit m in the self-  
20 ID packet has the function to indicate whether the station  
has some further ports or not. With the 1394 bus data  
communication is possible with half-duplex operation mode.  
Therefore, only one station is sending data to the bus and  
the rest is listening. The bus is granted to the stations in  
25 a deterministic manner depending on the bus topology (in  
particular whether a station is branch or leaf). The  
physical ID number is assigned to the stations in the order  
of bus grant beginning from Zero. For addressing a data  
packet not only the physical ID-number (node-ID) is used.  
30 Each bus also has a bus-ID which also needs to be taken into  
account during addressing.

In case of the bus structure shown in Fig. 1 a number of  
problems occur during self-configuration after a bus reset.  
35 The devices are not aware that they are connected via a  
wireless link to the network. The bridge makes a bus reset  
isolation. The self-ID packets need to be forwarded from one  
cluster to the other via the wireless link.

Now it is considered that a bus reset happened in the cluster bus 7. The reset is detected by all stations 1, 2, 3 in the cluster. After the bus reset the stations will send their self-ID packets one after the other. Each station in the cluster will collect the corresponding information in a higher software layer, e.g. in the transaction layer in order to be able to generate the right addresses later on. The interface 11 in the transceiver box 3 also receives each self-ID packet and forwards them via the wireless link to the second transceiver box 6. Also the box 3 generates a self-ID packet and sends it to the 1394 bus 7. In the first attempt wireless transceiver box 3 operates in legacy mode and generates a self-ID packet without taking into account that in case that the bridge is replaced by a 1394 cable, it would have a different physical ID number.

After having collected all self-ID packets from the cluster bus, the box 3 initiates a bus reset on the cluster bus by software means. Again the self-ID packets are transmitted over the bus. The difference is that when it is the turn of the box 3 to send its self-ID packet, it will generate not only its own self-ID packet but also all the self-ID packets of the stations in the remote cluster whereby the box 3 generates the self-ID packets under consideration of the topology which would result if the wireless link would be replaced by a 1394 cable. In the following the self-ID packets generated by the box 3 in representation of the stations in the cluster bus are called artificial self-ID packets.

Next, a bus reset is also initiated on the remote bus 8 by software means in box 6. The box 6 has collected all self-ID packets from the cluster bus and generates the corresponding artificial self-ID packets in this phase. After this phase the self-configuration is finalised and normal data communication can continue.

As explained above to achieve transparent operation, it is necessary that the Physical Layer chip in the interfaces 11

of the wireless transceiver box 3 and 6 generate self-ID packets that are reflecting the topology on both busses.

To do that the content of artificial self-ID packets to be  
5 generated automatically by the PHY IC will be stored in an  
specific buffer memory 22 in the PHY IC which can be a  
register bank (or RAM). Taking into account the format of a  
self-ID packet, only the information of the first quadlet of  
each self-ID packet will be stored in this register bank.  
10 The second quadlet of each self-ID packet will be created on  
the fly by the PHY chip itself (logical inverse of the first  
quadlet).

The number of self-ID packets per node is dependent on the  
15 implemented ports per node. The maximum number is three  
self-ID packets per node according to the IEEE1394-2000  
version and four in the standard IEEE 1394-1995. To be  
compatible with the old version leads to a minimum size of  
the register bank of

20

$$16 \text{ byte} * 62 \text{ nodes} = 992 \text{ bytes.}$$

The micro controller of the wireless link will provide the  
25 information of the artificial self-ID packets. This  
information is stored in the register bank of the PHY. In  
the following it is explained how the data is written in the  
register bank by means of link requests LREQs to PHY  
registers located in a reserved register page (register page  
30 2..7).

The concept of link requests is disclosed in the IEEE 1394  
standard itself. Every control command from the link IC is  
transferred to the PHY IC in the format shown in Fig. 4,  
35 which is defined in the 1394 standard. The command is  
delivered in serial form from LINK to PHY. After a start bit  
a three bit request type field and a 4 bit address field  
follows. Thereafter the instruction data byte follows. With  
the stop bit the command is finished.

The register bank should be organized in fixed areas corresponding to the node ID's (e.g. the reserved register space for self-ID packets of one node may be 16 byte). This will enable the PHY chip to respond immediately to PING packets addressed to a specific node ID by a simplified address resolve mechanism.

If the Self ID packets are placed in ascending order of node numbers in the buffer, the buffer size can be reduced by 6 bits per self-ID packet, which contains the physical node number. In addition the leading 10b bits in each self-ID packet has not to be stored in the register bank. From this it follows that the minimum size of the register bank will be:

$$12 \text{ byte} * 62 \text{ nodes} = 744 \text{ bytes.}$$

To address the buffer 10 binary digits are needed, whereby the 4 least significant bits, in the following denoted byte address, represent the address space for the self-ID data from one node, the 6 most significant bits represent the number of the node, in the following denoted node address.

The addressing scheme is shown in Fig. 5. Reference number 22 denotes the register bank or buffer memory. For addressing the buffer 22 during self-ID packet collection a node counter 30 and a byte counter 31 are provided. The node counter is 6 bits wide and the byte counter is a 4 bit counter. Both outputs together build the 10 bit address bus for the buffer memory. An 8 bit data bus is provided for delivering a data byte of a self-ID packet to the memory. The buffer memory can be of the DPRAM type (dual port RAM). In this case its content can be read out independently from the writing operation. Corresponding address and data busses are therefore also available at the other side of the buffer. A 6 bit data bus is connected to the node counter. This is necessary to be able to preset the node counter to a specific value.

The buffer memory is loaded by means of link requests. For this purpose the following instructions are newly defined (see table 1):

5

Address	Instruction	Actions
1000b	Write_byte	A byte of self-ID content will be written to the register bank. The byte counter is incremented. The node counter shall remain unchanged.
1001b	Write_last_of_ID	A byte of self-ID content will be written to the register bank. The byte counter is set to zero. The node counter is incremented.
1010b	Write_complete	A byte of a self-ID packet is written to the register bank. The node counter and byte counter are set to zero. The PHY chip shall respond to bus resets and PING packets in accordance to the content stored in the register bank.
1011b	Set_node_id_pointer	The node counter is set to the value given in the argument. The byte counter is set to zero. The content of the register bank will remain unchanged.
1100b	Tx/Rx_start	Defines the start value of the node counter for the register bank to transmit <b>or</b> receive self-ID packets depending on whether the register bank is in the transceiver box of the cluster bus or remote bus.
1101	Tx/Rx_end	Defines the end value of the node counter for the register bank to transmit <b>or</b>

		receive self-ID packets depending on whether the register bank is in the transceiver box of the cluster bus or remote bus.
1110b	Mode Remote ID_end	The 6 least significant bits of the ID_end register define the valid end address of the register bank in the current configuration. The Mode bit of this register enables/disables the transmission of artificial self-ID packets. The Remote bit defines the operation mode for reading the register bank.

**Table 1 Extended PHY instruction list**

The instructions listed in table 1 can be easily implemented by using reserved PHY registers in the PHY chip. In the IEEE 1394 standard eight register pages á 16 registers are provided among them the pages 2 ... 7 are reserved. The  
 5 extended PHY register map is shown in table 2.

	0	1	2	3	4	5	6	7
1000 <sub>2</sub>	Write byte							
1001 <sub>2</sub>	Write last of ID							
1010 <sub>2</sub>	Write complete							
1011 <sub>2</sub>			Set node id pointer					
1100 <sub>2</sub>			Tx/Rx start					
1101 <sub>2</sub>			Tx/Rx end					
1110 <sub>2</sub>	Mode	Remote	ID_end					
1111 <sub>2</sub>			Offset					

**Table 2 Extended PHY register map**

From Fig. 5 it is evident how the node counter 30 and byte  
 10 counter 31 are controlled by the different actions of the instructions in the table above.

In case that no self-ID packet information has been loaded in the register bank 22, the modified PHY IC should behave as a standard conform Physical layer IC (possibly with the  
5 *Root hold-off* bit and the *L* bit set to one). Physical Layer ICs are commercially available. E.g. the chip TSB21LV03 from Texas Instruments is a PHY IC for the IEEE 1394 bus.

Only when the register bank is completely loaded, indicated  
10 by writing the last byte of the register bank to the special register address "Write\_complete" and the number of nodes plus 128 (MSB set to one) has been written to ID\_end, the PHY IC shall respond to a bus reset (or to PING packets) with artificial self-ID packets according to the method  
15 described below.

A Physical layer IC shall send artificial self-ID packets in the node number range from zero to ID\_end **only** if one of the bits 24..29 (NPORT bits, port connection status) or bit 31  
20 (more\_packets) of the self-ID packet information is unequal zero. If the m (more\_packets) bit is set it shall provide immediately an additional self-ID packet for this node. If the content of the bits 24..29 or 31 is equal zero the Phy shall release the bus to allow other local nodes to provide  
25 their own self-ID packets. The Phy shall respond to PING packet only if the port\_connection\_status bits 24..29 or 31 are not equal zero for the requested node.

The modification of the two reserved bits (bridge bits) in  
30 the standard conform self-ID packet shall be implemented.

Additional the Phy shall recalculate the physical ID's for the artificial SelfID packets after every bus reset in case that a device is plugged in or plugged off. The new physical  
35 ID (Node\_ID\*) is calculated with the simple formula

$$\text{Node\_ID*} = \text{Node\_ID} + \text{Offset}$$

whereby Offset is defined as the difference of the number of received SelfID packets in the cluster after a bus reset plus one and the Rx/Tx\_start or Rx/Tx\_end value from the self-configuration phase before the bus reset.

5

In case the Phy is part of the remote bus:

$$\text{Offset} = (\text{number of received self-ID packets} + 1) - \text{Rx/Tx\_end}$$

10

In case the Phy is part of the cluster bus:

$$\text{Offset} = (\text{number of received self-ID packets} + 1) - \text{Rx/Tx\_start}.$$

15

Taking into account to which bus the node number '0' belongs, different buffer memory configurations are possible. They are shown in Fig. 6 and 7. Fig 6 shows the configurations in interface 11 at the transceiver box 6 of the remote bus for the case that the lowest node number '0' belongs i) to the remote bus and ii) to the cluster bus. Fig 7 shows the configurations in interface 11 at the transceiver box 3 of the cluster bus for the case that the lowest node number '0' belongs i) to the remote bus and ii) to the cluster bus. For example the case node ID 0 at cluster bus in Fig.6 is characterized that artificial self-ID packets need to be transmitted to the remote bus starting from physical ID '0' to physical ID 'tx/rx\_start minus 1' and in the range 'tx/rx\_end' to 'ID\_end minus 1'. In the range 'tx/rx\_start' to 'tx/rx\_end' the interface listens to the self-ID packets from the remote bus and forwards them to the other transceiver box 3. The buffer is empty from the address ID-end on.

20  
25  
30

35 With the concept of the offset value calculation for the node IDs each time after a bus reset it is possible to restart data communication very fast. This is because the transmittance of artificial self-ID packets is accelerated because it need not be waited until after a bus reset all

artificial self-ID packets are updated in the buffer memory. Instead the old entries are used again, apart from the physical-ID numbers that are modified with the offset value.

**Claims**

1. Interface circuit (11) for connecting a device to a first communication bus (7), the interface circuit (11) comprising a physical layer section (21) and a data link layer section (20), **characterized in that** the physical layer section (21) includes a buffer memory (22) in which self-identification packets received via a wireless bridge (9) from a second communication bus (8) are collected in order to be able to forward them to said first communication bus (7) after a bus reset or on demand.
2. Interface circuit according to claim 1, wherein a self-identification packet has a defined length and identifies a node on a communication bus.
3. Interface circuit according to claim 1 or 2 wherein during self-identification packet collection the buffer memory (22) is addressed by means of a node counter (30) and a data word counter (31) in order to store the data words of the self-identification packet.
4. Interface circuit according to claim 3, comprising a first control register which when addressed initiates an increment of the node counter (30) and said first control register is addressed each time the last data word of a self-identification packet is written in said buffer memory (22).
5. Interface circuit according to claim 4 wherein the first control register when addressed also initiates a reset of the data word counter (31).
6. Interface circuit according to one of claims 3 to 5, comprising a second control register which when addressed initiates an increment of the data word counter (31) and the second control register is addressed each time a data word is written into said buffer memory (22).

7. Interface circuit according to one of claims 3 to 6, further comprising a third control register which when addressed initiates a reset of the node counter (30) and data word counter (31), and the third control register is  
5 addressed each time the last data word of the self-identification packet is written into said buffer memory (22).

8. Interface circuit according to one of claims 3 to 7,  
10 comprising a fourth control register which when addressed initiates a preset of the node counter (30) to a value specified on corresponding data lines.

9. Interface circuit according to claim 8, wherein the  
15 fourth control register when addressed also initiates a reset of the data word counter (31).

10. Interface circuit according to one of claims 1 to 9 further comprising a fifth and sixth register in which a  
20 start value and an end value of a specific range in said buffer memory (22) are stored for facilitating determination of the memory location that needs to be read out during a self-configuration phase of said network of bus stations of said first and second communication bus.

25

11. Interface circuit according to one of claims 1 to 10 further comprising a seventh register in which the address of the last valid entry in the buffer memory (22) is stored.

30 12. Interface circuit according to claim 11 wherein the seventh register includes an additional bit position with which the transmission of artificial self-identification packets can be enabled or disabled.

35 13. Interface circuit according to one of claims 1 to 12, further comprising means for calculating an offset value for the modification of node ID numbers in the stored self-identification packets each time after a bus reset, wherein the offset value is calculated as the difference of the

number of received self-identification packets after a bus reset on either the first or second communication bus plus one and the start or end value in the fifth and sixth register depending on whether the interface circuit (11) is  
5 part of a cluster (7) or remote bus (8).

14. Interface circuit according to claims 12 or 13, wherein the seventh register includes an additional bit position with which two modes of reading self-identification  
10 packets out of the buffer memory (22) can be distinguished, namely whether or not the interface circuit (22) is part of a remote bus (8) or cluster bus (7).

15. Interface circuit according to one of claims 1 to 14, wherein the first and second communication bus is a standard wired IEEE 1394 bus and said wireless bridge (9) is a wireless bridge particular in accordance with Hiperlan/2, IEEE 802.11 or Bluetooth standard.

20

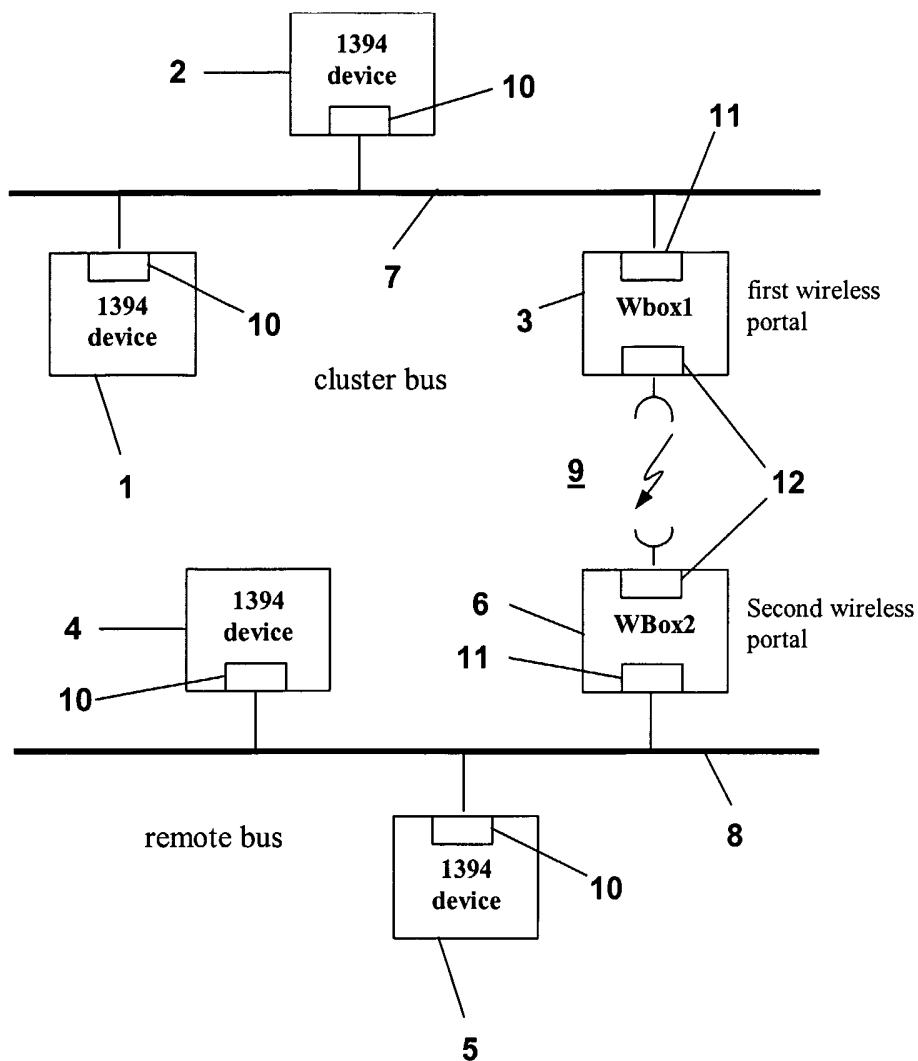

Fig. 1

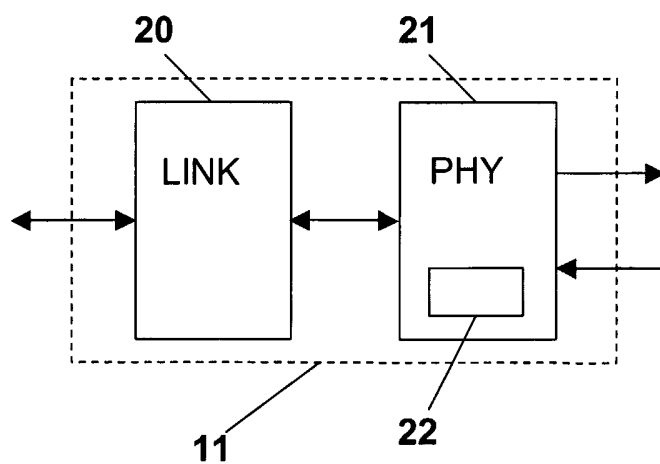

Fig. 2

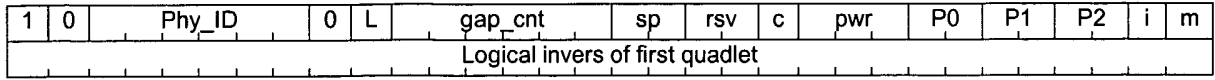

Fig. 3



Fig. 4

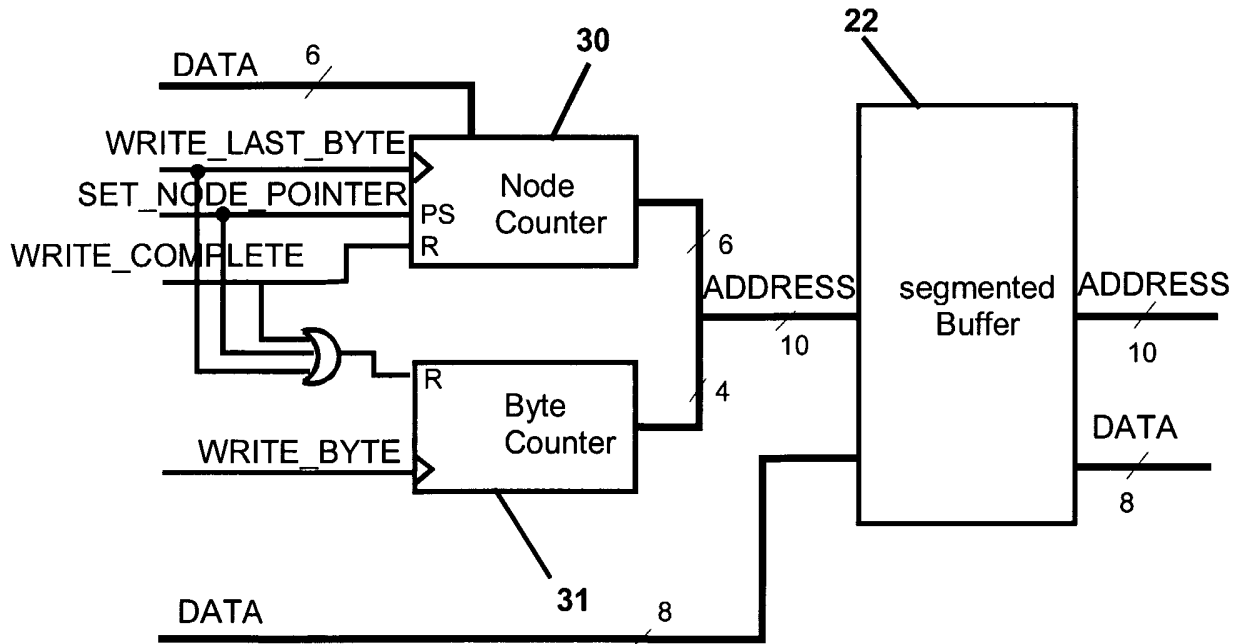
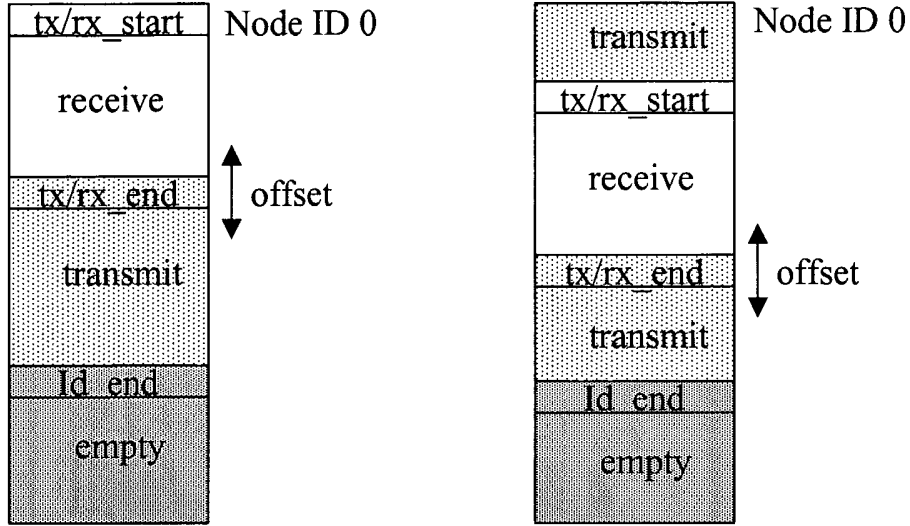

Fig. 5

### NodeID Register bank at the remote side



Node ID 0 at remote bus

Node ID 0 at cluster bus

**Fig. 6**

### NodeID Register bank at the cluster side

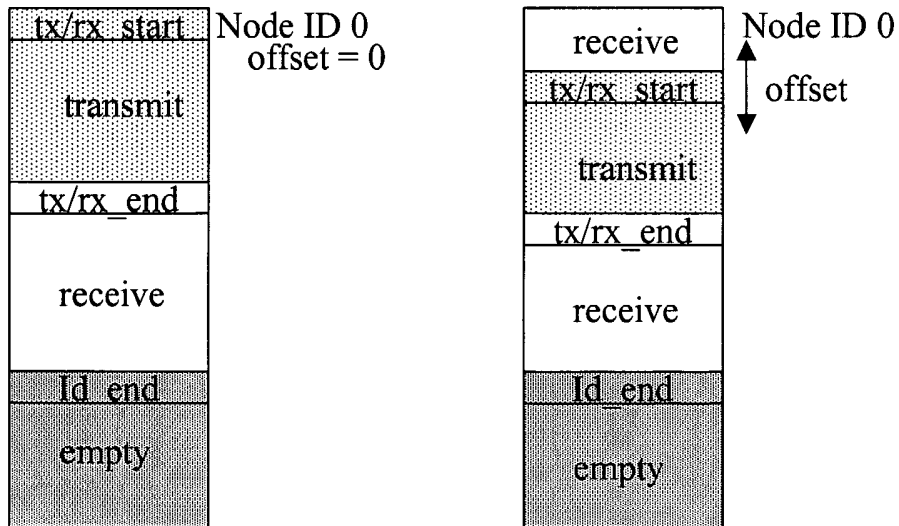

Node ID 0 at remote bus

Node ID 0 at cluster bus

**Fig. 7**