

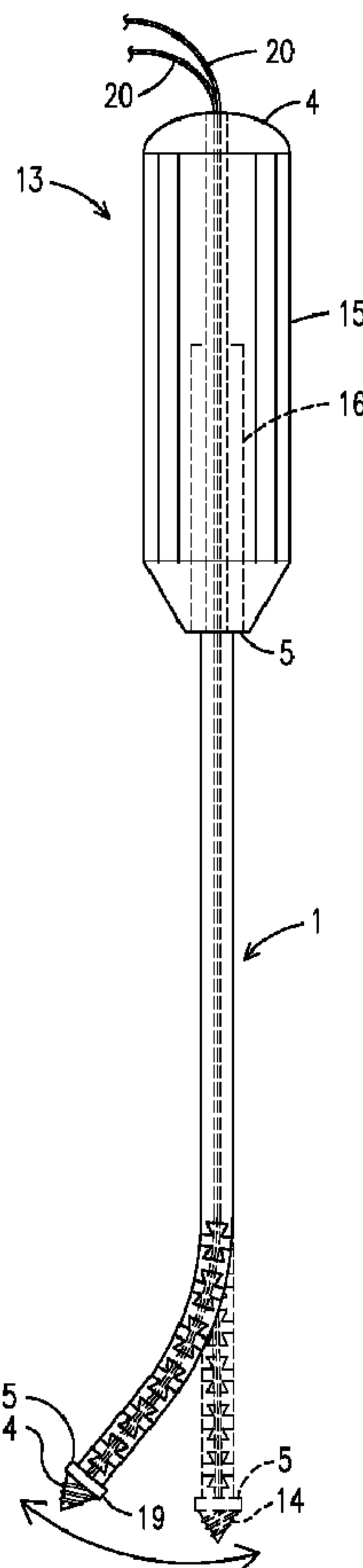

(86) **Date de dépôt PCT/PCT Filing Date:** 2011/04/05  
 (87) **Date publication PCT/PCT Publication Date:** 2011/12/29  
 (45) **Date de délivrance/Issue Date:** 2016/10/04  
 (85) **Entrée phase nationale/National Entry:** 2012/12/11  
 (86) **N° demande PCT/PCT Application No.:** US 2011/031202  
 (87) **N° publication PCT/PCT Publication No.:** 2011/162853  
 (30) **Priorités/Priorities:** 2010/06/23 (US61/357,651);  
 2010/12/15 (US12/968,556)

(51) **Cl.Int./Int.Cl. A61B 17/16** (2006.01)  
 (72) **Inventeurs/Inventors:**  
 PAPENFUSS, HANS B., US;  
 PAPENFUSS, ERIK H., US  
 (73) **Propriétaire/Owner:**  
 LENKBAR, LLC, US  
 (74) **Agent:** BLAKE, CASSELS & GRAYDON LLP

(54) **Titre : TIGE DE COMMANDE FLEXIBLE CANULEE**  
 (54) **Title: CANNULATED FLEXIBLE DRIVE SHAFT**



(57) **Abrégé/Abstract:**

The current invention is described using a preferred embodiment that uses indicator dilution, such as injecting a saline solution and sensing the presence of indicator and its concentration with an ultrasound sensor. Those of ordinary skill in the art, once they



**(57) Abrégé(suite)/Abstract(continued):**

understand the principles of the current invention will realize that other physical properties of the blood can be changed and other types of sensors can be used to obtain the dilution curves without departing from the spirit of the invention. Among potential changes in blood properties possible are its optical properties, electrical proprieties (electrical impedance), thermal properties, or any other appropriate physical or chemical properties of the blood. Accordingly, optical sensors, electrical sensors, thermal sensors, or other appropriate physical or chemical sensors can be used, maybe used depending on the change in the property of the blood made. Additionally, isotope tracers with appropriate sensors could be used. This is not meant to be an exhaustive list. The equations can be modified to work with different indicators which will not depart from the spirit of the invention.

**[0041]** The current invention is described using a preferred embodiment that uses indicator dilution, such as injecting a saline solution and sensing the presence of indicator and its concentration with an ultrasound sensor. Those of ordinary skill in the art, once they understand the principles of the current invention will realize that other physical properties of the blood can be changed and other types of sensors can be used to obtain the dilution curves without departing from the spirit of the invention. Among potential changes in blood properties possible are its optical properties, electrical properties (electrical impedance), thermal properties, or any other appropriate physical or chemical properties of the blood. Accordingly, optical sensors, electrical sensors, thermal sensors, or other appropriate physical or chemical sensors can be used. maybe used depending on the change in the property of the blood made. Additionally, isotope tracers with appropriate sensors could be used. This is not meant to be an exhaustive list. The equations can be modified to work with different indicators which will not depart from the spirit of the invention.

## CANNULATED FLEXIBLE DRIVE SHAFT

### CROSS REFERENCE TO RELATED APPLICATION

This application claims the benefit of U.S. Provisional Patent Application No.61/357,651, filed June 23, 2010.

5

### BACKGROUND OF THE INVENTION

This invention relates to tools used for performing surgeries, such as arthroscopic or orthopedic procedures, more particularly, a cannulated flexible drive shaft having a plurality of interlocking sections, preferably locked together by multi-angled dovetails, along the shaft that allow a distal end to be flexible while withstanding the torque from being rotated clockwise or counterclockwise thereby preventing the dovetails from separating and failing.

The limitations on maneuverability imposed by arthroscopic surgery mean that conventional straight drive shafts are not well suited for such procedures. Therefore, various arthroscopic surgical procedures utilize flexible drive shafts to drill into bone, ream bone, punch holes into bone, push anchors or screws into bone, tap anchors or screws into bone, screw anchors or screws into bone and securing sutures to bone, tendons and so forth. Conventional flexible drive shafts have a helical coil located along the entire drive shaft or along a portion of the distal end of the drive shaft. The helical coil allows a user to pass the drive shaft through a bent guide. However, depending on the orientation of a helical design, the coils will tighten together when turned clockwise and separate or pull apart when turned

counterclockwise or vice versa for drive shafts having a helical design with an opposite orientation. Therefore, currently a surgeon needs two flexible drive shafts. One that will transmit torque in a clockwise direction and one that will transmit torque in a counterclockwise direction.

5 Therefore, a need exists for a cannulated flexible drive shaft that will transmit torque in a clockwise direction as well as a counterclockwise direction without the drive shaft being pulled apart.

	<u>Patent/Serial No.</u>	<u>Inventor</u>	<u>Issue/Publication Date</u>
	<u>U.S. Patent Documents</u>		
10	7,604,643	Ciccone et al.	10-20-2009
	2009/0182288	Spenciner	07-16-2009
	2008/0221392	Jorgensen	09-11-2008
	2005/0033365	Courage	02-10-2005
	6,447,518	Krause et al.	09-10-2002
15	6,214,012	Karpman et al.	04-10-2001
	6,053,922	Krause et al.	04-25-2000
	6,010,507	Rudloff	01-04-2000
	5,681,333	Burkhart et al.	10-28-1997
	5,584,839	Gieringer	12-17-1996
20	5,562,667	Shuler et al.	10-08-1996
	5,464,407	McGuire	11-07-1995
	<u>Foreign Patent Documents</u>		
	EP2140824	Biederman et al.	06-01-2010
	CN2642256	Wang	09-22-2004
25	<u>Other Publications</u>		
	"Percutaneous Closed Reduction of Fracture Dislocation of the Shoulder," by Silver et al.;		
	"Endius launches NorthStar Cannulated Screw Delivery System," Biotech Week October, 2006;		
	"Strategic Orthopaedics," by Jackie Orsagh, Business People September, 2006.		

## SUMMARY OF THE INVENTION

The primary object of the present invention is to provide a flexible drive shaft that will transmit torque in a clockwise direction as well as a counterclockwise direction.

A further object of the present invention is to provide a flexible drive shaft that is  
5 strong enough to withstand the torque being placed on it while in use.

The present invention fulfills the above and other objects by providing a flexible cannulated drive shaft having a plurality of interlocking sections having an angled dovetail design cut into the drive shaft. Each interlocking section has a proximal end, a distal end and a dovetail design comprising substantially triangular-shaped pins and substantially triangular-  
10 shaped sockets that alternate around the circumference of the proximal end and/or distal end of each interlocking section. The pins of one interlocking section moveably engage the sockets of a second interlocking section and vice versa. The substantially triangular-shaped pins and substantially triangular-shaped sockets secure the interlocking sections together while allowing the drive shaft to be flexible. An additional benefit of the interlocking  
15 sections is that the distance between each section may be cut larger or smaller to achieve a more or less flexible drive shaft. Furthermore, the substantially triangular-shaped pins and substantially triangular-shaped sockets stay locked together whether the drive shaft is being rotated clockwise or counterclockwise. The drive shaft may be used as a manual tool, such as a screw driver, or attached to a rotational tool, such as a drill. A guide allows a user to  
20 control the placement and depth of the distal end of the drive shaft during operations.

The above and other objects, features and advantages of the present invention should become even more readily apparent to those skilled in the art upon a reading of the following detailed description in conjunction with the drawings wherein there is shown and described illustrative embodiments of the invention.

5

#### BRIEF DESCRIPTION OF THE DRAWINGS

In the following detailed description, reference will be made to the attached drawings in which:

**FIG. 1** is an isometric perspective view of a flexible cannulated drive shaft of the present invention;

10

**FIG. 2** is a side view of dovetail sections from a flexible cannulated drive shaft of the present invention;

**FIG. 3** is an exploded top plan view of a laid flat interlocking section dovetail design and a top view of a laid flat opposing interlocking section dovetail design of the present invention;

15

**FIG. 4** a cross section of an interlocking section along line 4-4 of **FIG. 3**;

**FIG. 5** a cross section of an interlocking section along line 5-5 of **FIG. 3**;

**FIG. 6** a cross section of an interlocking section along line 6-6 of **FIG. 3**;

**FIG. 7** a cross section of an interlocking section along line 7-7 of **FIG. 3**;

**FIG. 8** a cross section of an interlocking section along line 8-8 of **FIG. 3**;

20

**FIG. 9** a cross section of an interlocking section along line 9-9 of **FIG. 3**;

**FIG. 10** is a side plan view of a screwdriver having a flexible cannulated drive shaft of the present invention therein;

**FIG. 11** is a side plan view of an external guide of the present invention;

**FIG. 12** is a side view of an internal guide of the present invention;

5 **FIG. 13** is a side perspective view of a flexible cannulated drive shaft of the present invention comprising a dovetail design having substantially round-shaped pins and substantially round-shaped sockets; and

**FIG. 14** is a protective sheath of the present invention.

DESCRIPTION OF THE PREFERRED EMBODIMENTS

10 For purposes of describing the preferred embodiment, the terminology used in reference to the numbered components in the drawings is as follows:

- |                         |                             |
|-------------------------|-----------------------------|
| 1. drive shaft          | 15. handle                  |
| 2. outer surface        | 16. hollow portion          |
| 3. inner surface        | 17. external guide          |
| 15 4. proximal end      | 18. stop                    |
| 5. distal end           | 19. head                    |
| 6. interlocking section | 20. suture                  |
| 7. pin                  | 21. inward angled surface   |
| 8. socket               | 22. outward angled surface  |
| 20 9. template          | 23. inner portion of socket |
| 10. tubular shaft       | 24. side portion of pin     |
| 11. cut                 | 25. outer portion of pin    |
| 12. edge                | 26. internal guide          |
| 13. screw driver        | 27. handle                  |
| 25 14. suture anchor    | 28. protective sheath       |

With reference to **FIGS. 1** and **2**, a side perspective view of a flexible cannulated drive shaft **1** of the present invention and a side view of interlocking sections **6** of the present

invention, respectively, are shown. The drive shaft 1 is preferably tubular and comprises an outer surface 2, an inner surface 3, a proximal end 4 and a distal end 5. A plurality of interlocking sections 6 are located along the drive shaft 1. As shown in FIG. 2, each interlocking section 6 has a proximal end 4, a distal end 5 and a dovetail design 9 comprising

5 substantially triangular-shaped pins 7 and substantially triangular-shaped sockets 8 that alternate around the circumference of the proximal end 4 and/or distal end 5 of each interlocking section 6. The preferred shape of the pins 7 and sockets 8 is substantially triangular shaped, however the pins 7 and sockets 8 may also be substantially round shaped.

The pins 7 of one interlocking section 6 moveably engage the sockets 8 of a second

10 interlocking section 8 and vice versa. The substantially triangular-shaped pins 7 and substantially triangular-shaped sockets 8 secure the interlocking sections 6 together while allowing the drive shaft 1 to be flexible. The substantially triangular-shaped pins 7 and corresponding substantially triangular-shaped sockets 8 are cut at opposing angles (as illustrated further in FIGS. 4-10) to allow for increased flexibility and to further lock the

15 sections 6 together and prevent the interlocking sections from separating. Furthermore, the substantially triangular-shaped pins 7 and substantially triangular-shaped sockets 8 stay locked together whether the drive shaft 1 is being rotated clockwise or counterclockwise.

Now referring to FIG. 3, an exploded top view of a laid flat interlocking section 6 dovetail design 9 and a top view of a laid flat opposing interlocking section 6 dovetail design

20 9 of the present invention is shown. The flexible portion of the drive shaft 1 is made by

cutting interlocking sections **6** into a tubular shaft **10**. Each cut **11** is made around the entire circumference of the tubular shaft **10** to create a dovetail design **9** comprising alternating substantially triangular-shaped pins **7** and substantially triangular-shaped sockets **8**. The substantially triangular-shaped pins **7** and corresponding substantially triangular-shaped sockets **8** are cut at opposing angles to allow for increased flexibility and to further lock the sections **6** together and prevent the interlocking sections from separating. Each triangular-shaped pins **7** has inward angled surfaces **21** and outward angled surfaces **22** that correspond to inward angled surfaces **21** and outward angled surfaces **22** of an opposing triangular-shaped socket **8**. The inward angled surfaces **21** or outward angled surfaces **22** may be located on inner portions **23** of triangular-shaped sockets **8**, side portions **24** of triangular-shaped pins **7** or outer portions **25** of triangular-shaped pins **7**.

Now referring to **FIG. 4**, a cross section of an interlocking section along line 4-4 of **FIG. 3** showing inward angled surfaces **21** located on inner portions **23** of triangular-shaped sockets **8**.

Now referring to **FIG. 5**, a cross section of an interlocking section along line 5-5 of **FIG. 3** showing outward angled surfaces **22** located on side portions **24** of a triangular-shaped pin **7**.

Now referring to **FIG. 6**, a cross section of an interlocking section along line 6-6 of **FIG. 3** showing inward angled surfaces **21** located on outer portions **25** of triangular-shaped pins **7**.

Now referring to **FIG. 7**, a cross section of an interlocking section along line 7-7 of **FIG. 3** showing outward angled surfaces **22** located on inner portions **23** of triangular-shaped sockets **8**.

Now referring to **FIG. 8**, a cross section of an interlocking section along line 8-8 of **FIG. 3** showing inward angled surfaces **21** located on side portions **24** of a triangular-shaped pin **7**.

Now referring to **FIG. 9**, a cross section of an interlocking section along line 9-9 of **FIG. 3** showing outward angled surfaces **22** located on outer portions **25** of triangular-shaped pins **7**.

Now referring to **FIG. 10**, a side plan view of a screwdriver **13** having a flexible cannulated drive shaft **1** of the present invention therein is shown. The screwdriver **13** may be used for inserting a suture anchor **14** into a bone. The screwdriver **13** comprises a proximal end **4** and a distal end **5**. A handle **15** is located on the proximal end **4** of the screwdriver **13**. A flexible cannulated drive shaft **1** extends outward from the distal end **5** of the handle **15**. A hollow portion **16** of the handle **15** accepts a proximal end **4** of an external guide **17** (as shown in **FIG. 11**) and works in conjunction with a stop **18** located on the guide **17** to control the distance that the drive shaft **1** is able to extend from a distal end **5** of the guide **17**. A head **19** located on the distal end **5** of the drive shaft **1** is used to engage and rotate the suture anchor **14**. A plurality of interlocking sections **6** are located along the drive shaft **1** near the distal end **5** of the screwdriver **13**. The handle **15** of the screwdriver **13** is

preferably tubular to allow for a suture **20** attached to the suture anchor **14** to be passed through the handle **15**. Although the flexible cannulated drive shaft **1** shown here is attached to a handle **15**, it may be attached to any rotational tool, such as a drill.

Now referring to **FIG. 11**, a side plan view of an external guide **17** of the present invention is shown. The external guide **17** is preferably a tubular shaft having a proximal end **4** and a distal end **5**. The external guide **17** may be bent and curved to control the positioning of the drive shaft **1** during operations. The distal end **8** of the external guide **17** is preferably pointed so that the pointed distal end can be inserted into a bone, thereby locking the external guide **17** in place on the bone. A stop **18** is located on the near the proximal end **4** of the external guide **17**. A hollow portion **16** of the handle **15** (as shown in **FIG. 5**) accepts the proximal end **4** of the external guide **17** and works in conjunction with the stop **18** located on the external guide **17** to control the depth that the drive shaft **1** is able to extend out of the distal end **5** of the external guide **17**. The stop **18** may be adjustable to allow a user to increase the distance between the proximal end **4** of the external guide **17** and the stop **18**.

Now referring to **FIG. 12**, a side view of an internal guide **26** of the present invention is shown. The internal guide **26** is preferably a tubular shaft having a proximal end **4** and a distal end **5**. A handle **27** is preferably located on the proximal end **4** of the internal guide **26**. The internal guide **26** is preferably constructed from shape memory alloy or any other shape memory material that has an elastic effect, thereby allowing a user to forge a constant curve in the material that can be temporarily straitened when pressure is applied the curve.

The internal guide **26** is used to control the positioning of the drive shaft **1** during operations. The curved section of the internal guide **26** may be temporarily straitened to be passed through the tubular handle **15** of the screwdriver **13** and through the cannulated drive shaft **1**. The curved section of the internal guide **26** will the return to its curved shape, thereby  
5 placing a desired curve in the flexible portion of the cannulated drive shaft **1**.

Now referring to **FIG. 13**, a side perspective view of a flexible cannulated drive shaft **1** of the present invention comprising a dovetail design **9** having substantially round-shaped pins **7** and substantially round-shaped sockets **8**

Finally referring to **FIG. 14**, a protective sheath **28** of the present invention is shown.  
10 The protective sheath **28** is preferable made of a plastic or rubber material and is placed over the cannulated drive shaft **1** to cover the interlocking sections **6**. The protective sheath **28** prevents the gaps between the interlocking sections **6** from becoming filled with foreign matter.

It is to be understood that while a preferred embodiment of the invention is  
15 illustrated, it is not to be limited to the specific form or arrangement of parts herein described and shown. It will be apparent to those skilled in the art that various changes may be made without departing from the scope of the invention and the invention is not to be considered limited to what is shown and described in the specification and drawings.

**CLAIMS:**

1. A cannulated flexible drive shaft comprising:
  - a tubular shaft having a proximal end, a distal end, an inner surface and an outer surface; and
  - at least two interlocking sections located on the tubular shaft, said at least two interlocking sections each having at least one pin and at least one socket,
  - said at least two interlocking sections comprising a first interlocking section and a second interlocking section,
  - the at least one pin on the first interlocking section having a circumferential width that increases as said at least one pin on the first interlocking section extends from the outer surface of the shaft to the inner surface of the shaft, so that said at least one pin on the first interlocking section becomes gradually wider toward the inner surface,
  - the at least one pin on the second interlocking section having a circumferential width that decreases as said at least one pin on the second interlocking section extends from the outer surface of the shaft to the inner surface of the shaft, so that said at least one pin on the second interlocking section becomes gradually narrower toward the inner surface.
2. The cannulated flexible drive shaft of claim 1 wherein: said at least two interlocking sections are cut at opposing angles to create at least one inward angled surface and at least one outward angled surface; and said at least one inward angled surface is adjacent to the at least one outward angled surface.
3. The cannulated flexible drive shaft of claim 1 wherein: each of the pins is substantially triangular shaped; and each of the sockets is substantially triangular shaped.
4. The cannulated flexible drive shaft of claim 3 wherein: the pins and sockets are cut at opposing angles to create at least one inward angled surface and at least one outward angled surface; and said at least one inward angled surface is adjacent to the at least one outward angled surface.
5. The cannulated flexible drive shaft of claim 1 wherein: each of the pins is substantially round shaped; and each of the sockets is substantially round shaped.

6. The cannulated flexible drive shaft of claim 5 wherein: the pins and sockets are cut at opposing angles to create at least one inward angled surface and at least one outward angled surface; and said at least one inward angled surface is adjacent to the at least one outward angled surface.
7. The cannulated flexible drive shaft of claim 1 further comprising: a handle located on the proximal end of the tubular shaft.
8. The cannulated flexible drive shaft of claim 7 wherein: said handle is substantially tubular, thereby allowing a user to pass an object through the handle and through the tubular shaft.
9. The cannulated flexible drive shaft of claim 1 further comprising: a substantially tubular shaped external guide configured for placement over the external surface of the drive shaft to control a curve of the tubular shaft.
10. The cannulated flexible drive shaft of claim 1 further comprising: an internal guide configured for placement into the tubular shaft to control a curve of the tubular shaft.
11. The cannulated flexible drive shaft of claim 10 wherein: said internal guide is constructed out of a shape memory alloy.
12. The cannulated flexible drive shaft of claim 1 further comprising: a protective sheath configured to cover a predetermined portion of the external surface of the tubular shaft.
13. A cannulated flexible drive shaft comprising:
  - a tubular shaft having a proximal end, a distal end, an inner surface and an outer surface; and
  - at least two interlocking sections located on the tubular shaft, said at least two interlocking sections each having at least one pin and at least one socket,
  - said at least two interlocking sections are cut at opposing angles to create at least one inward angled surface and at least one outward angled surface, said at least one inward angled surface is adjacent to the at least one outward angled surface,

said at least two interlocking sections comprising a first interlocking section and a second interlocking section,

the at least one pin on the first interlocking section having a circumferential width that increases as said at least one pin on the first interlocking section extends from the outer surface of the shaft toward the inner surface of the shaft, so that said at least one pin on the first interlocking section becomes gradually wider toward the inner surface,

the at least one pin on the second interlocking section having a circumferential width that decreases as said at least one pin on the second interlocking section extends from the outer surface of the shaft toward the inner surface of the shaft, so that said at least one pin on the second interlocking section becomes gradually narrower toward the inner surface.

14. The cannulated flexible drive shaft of claim 13 wherein: each of the pins is substantially triangular shaped; and each of the sockets is substantially triangular shaped.

15. The cannulated flexible drive shaft of claim 14 wherein: the pins and sockets are cut at opposing angles to create said at least one inward angled surface and said at least one outward angled surface.

16. The cannulated flexible drive shaft of claim 13 wherein: each of the pins is substantially round shaped; and each of the sockets is substantially round shaped.

17. The cannulated flexible drive shaft of claim 16 wherein: the pins and sockets are cut at opposing angles to create said at least one inward angled surface and said at least one outward angled surface.

18. The cannulated flexible drive shaft of claim 13 further comprising: a handle located on the proximal end of the tubular shaft.

19. The cannulated flexible drive shaft of claim 18 wherein: said handle is substantially tubular, thereby allowing a user to pass an object through the handle and through the tubular shaft.

20. The cannulated flexible drive shaft of claim 13 further comprising: a substantially tubular shaped external guide configured for placement over the external surface of the drive shaft to control a curve of the tubular shaft.

21. The cannulated flexible drive shaft of claim 13 further comprising: an internal guide configured for placement into the tubular shaft to control a curve of the tubular shaft.

22. The cannulated flexible drive shaft of claim 21 wherein: said internal guide is constructed out of a shape memory alloy.

23. The cannulated flexible drive shaft of claim 13 further comprising: a protective sheath configured to cover a predetermined portion of the external surface of the tubular shaft.

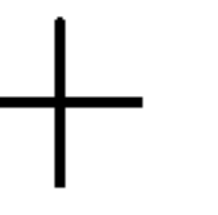

1/4

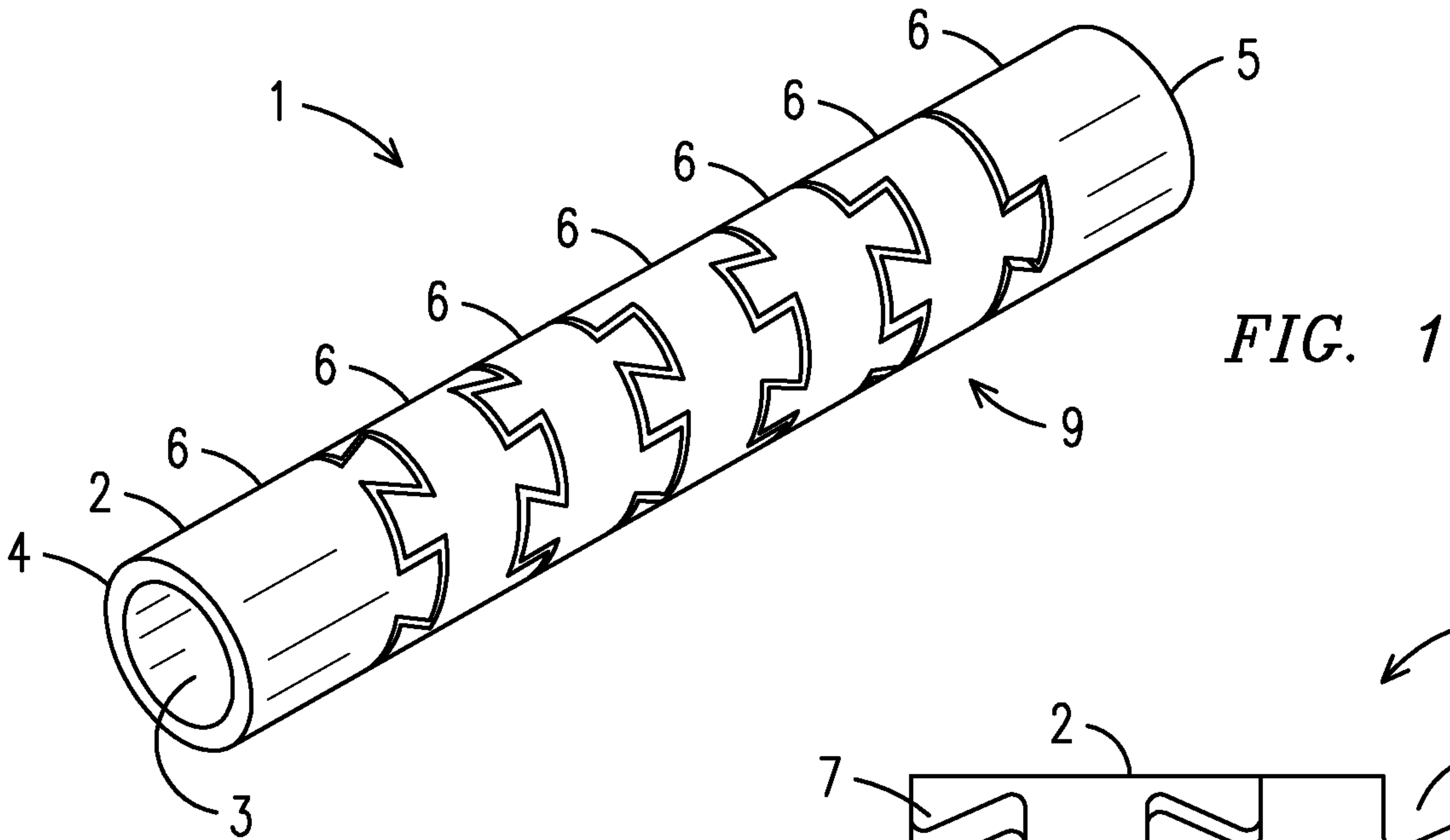
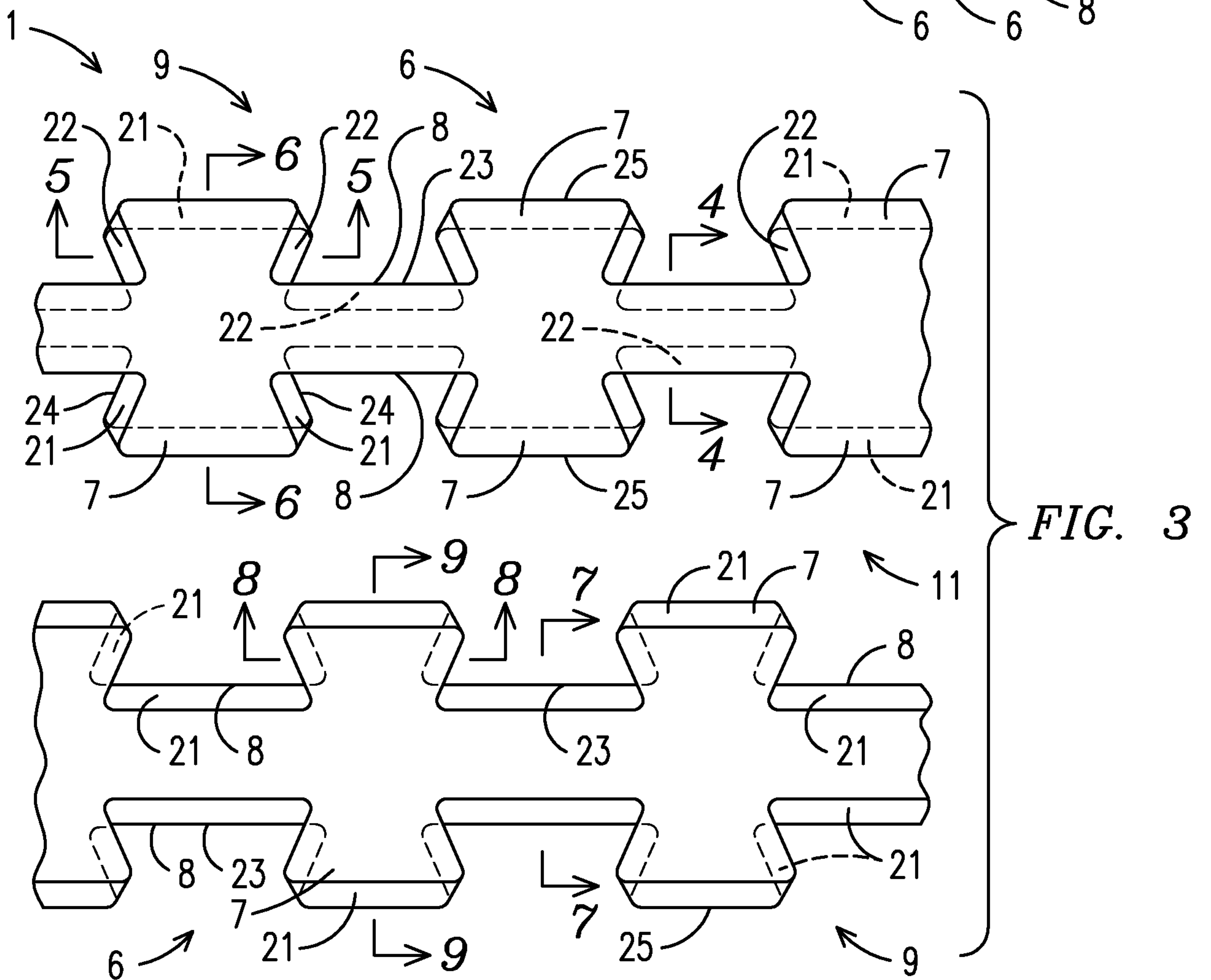
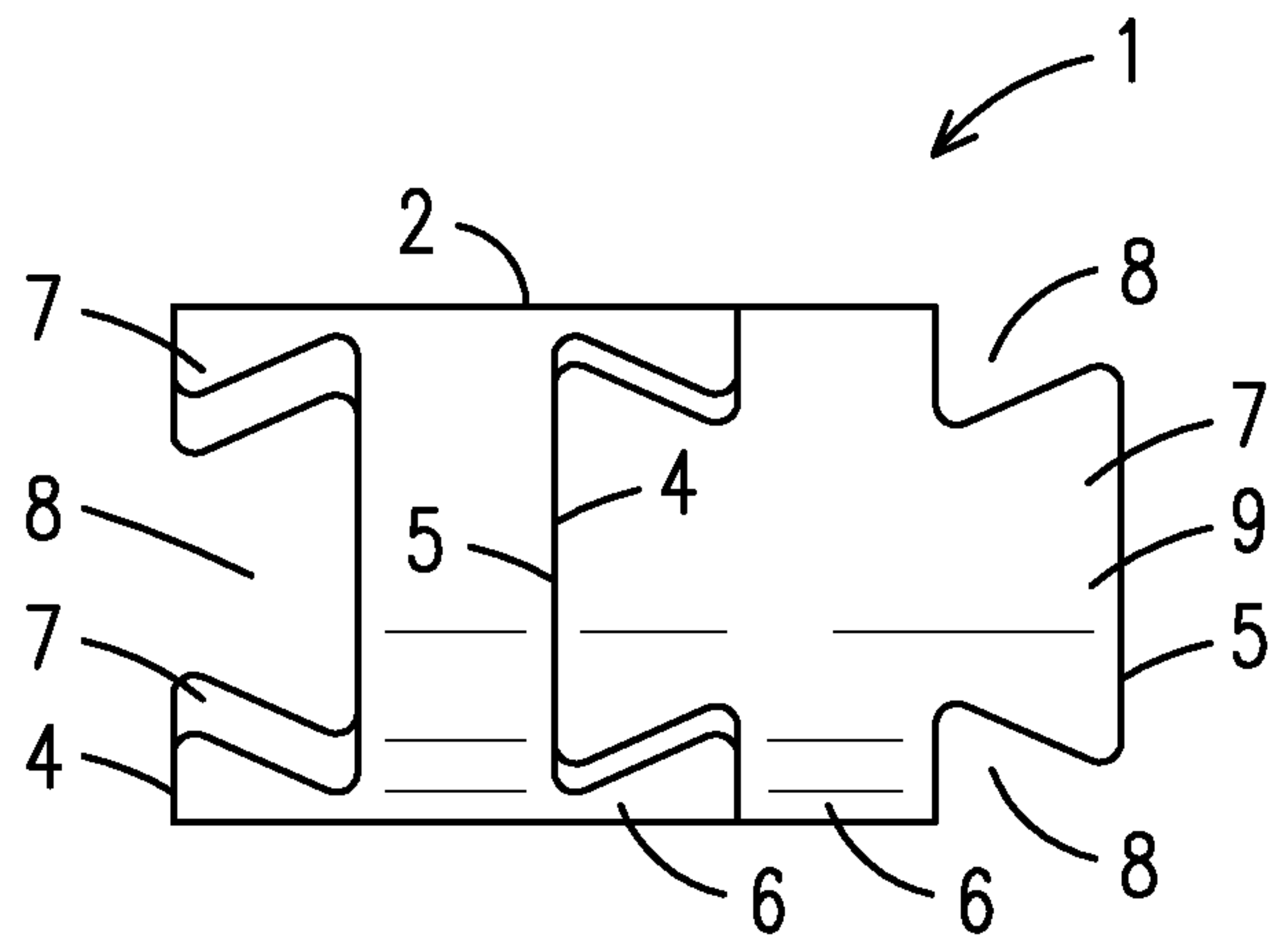

FIG. 2



2/4

+

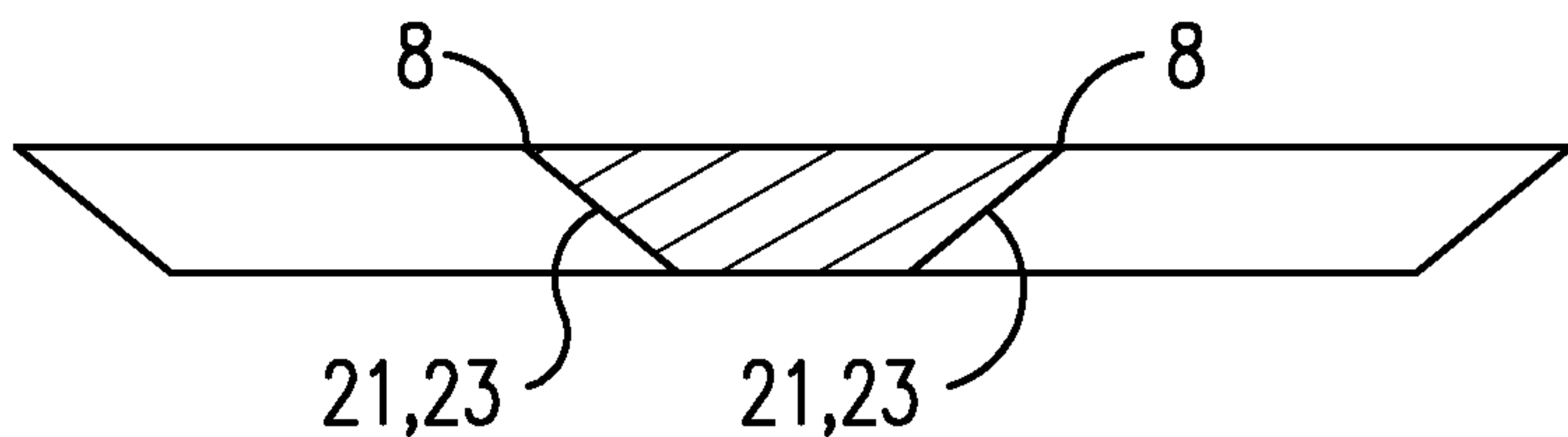

FIG. 4

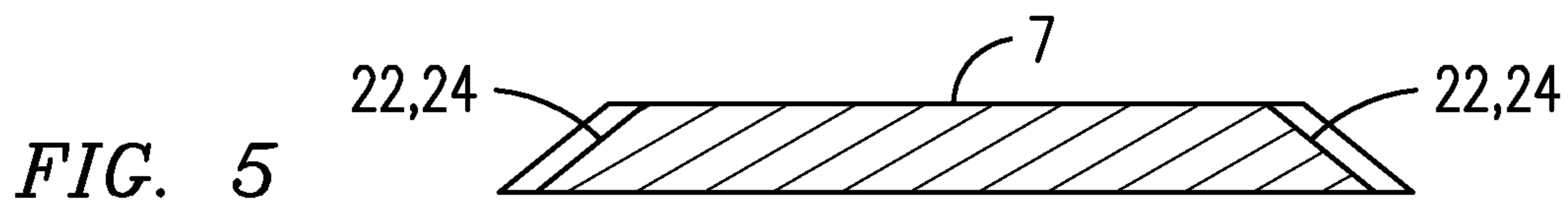

FIG. 5

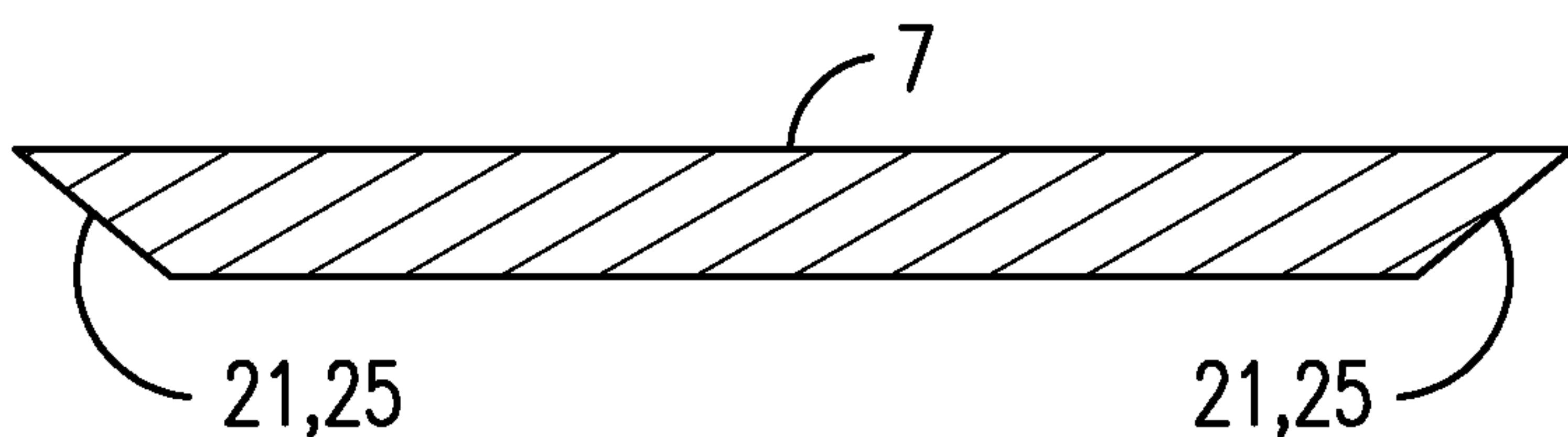

FIG. 6

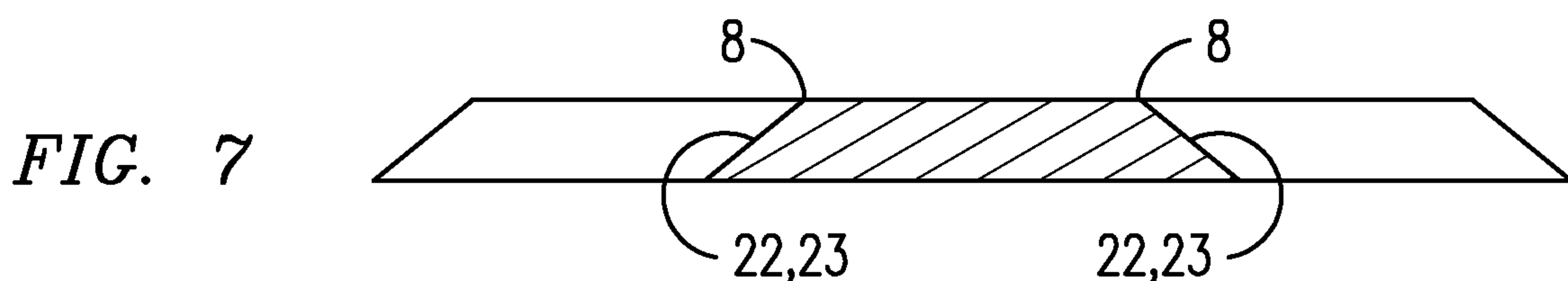

FIG. 7

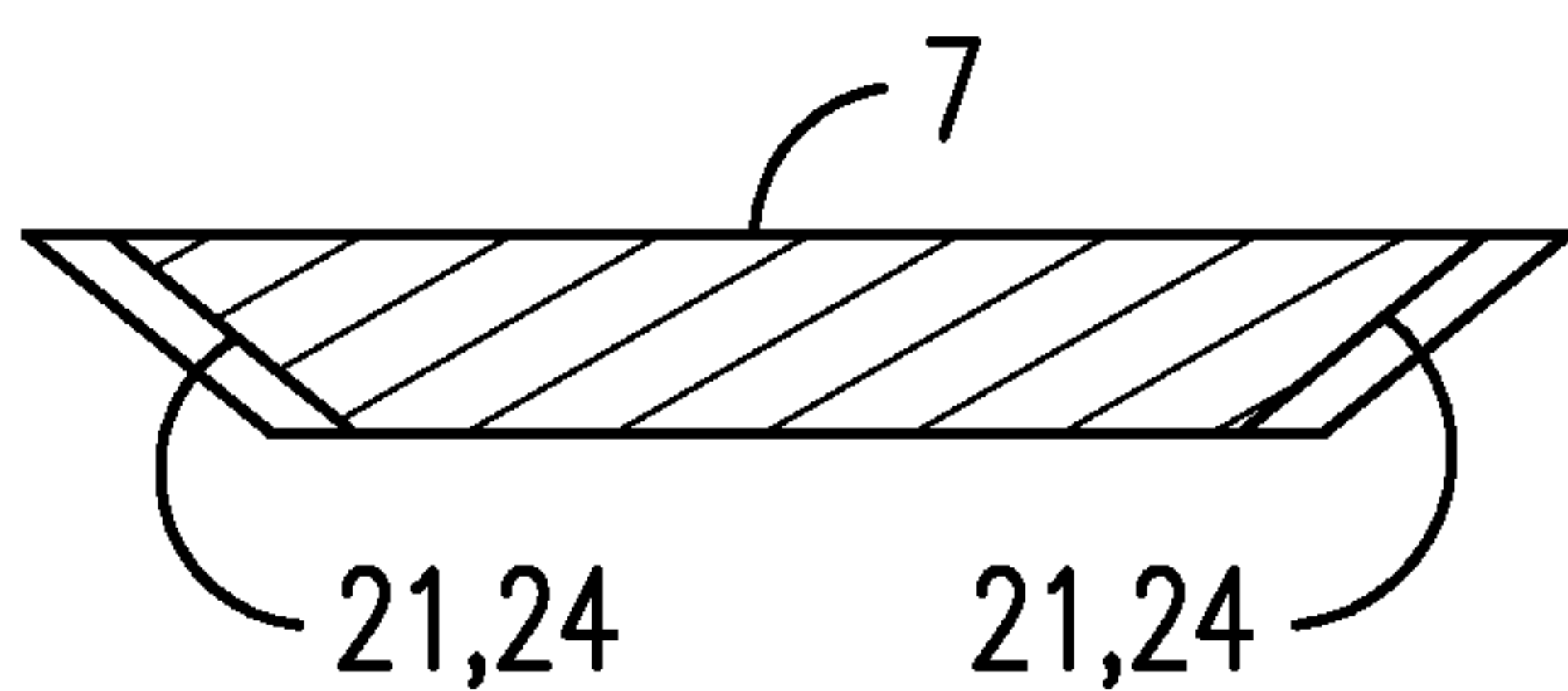

FIG. 8

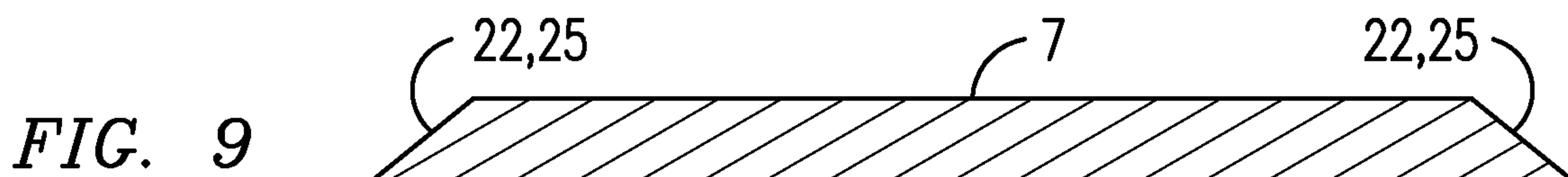

FIG. 9

+

3/4

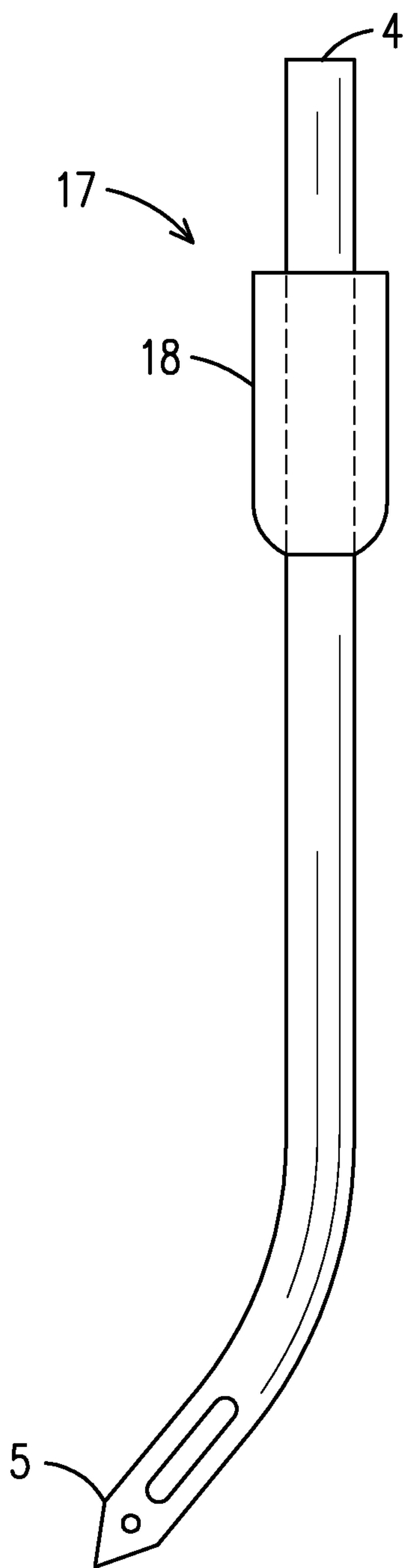

FIG. 11

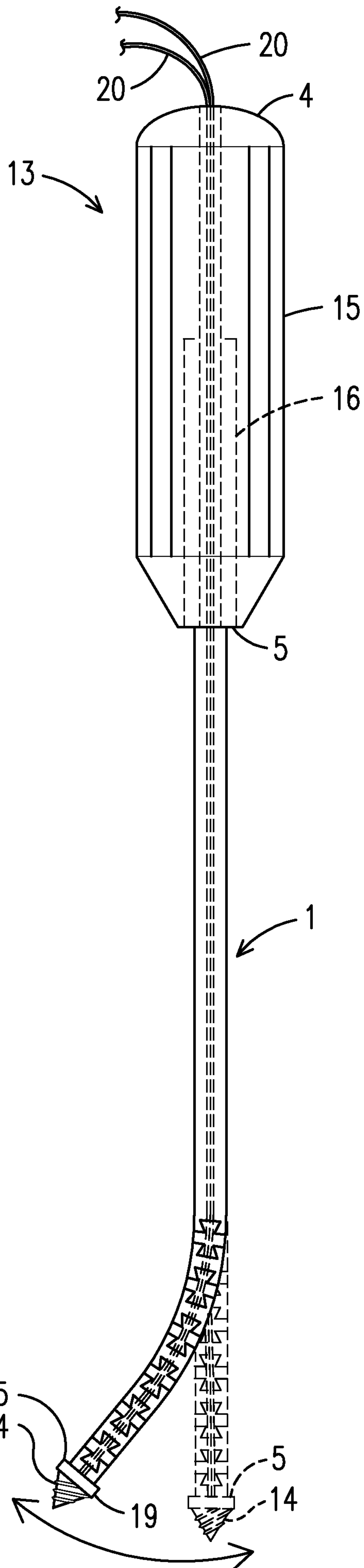

FIG. 10

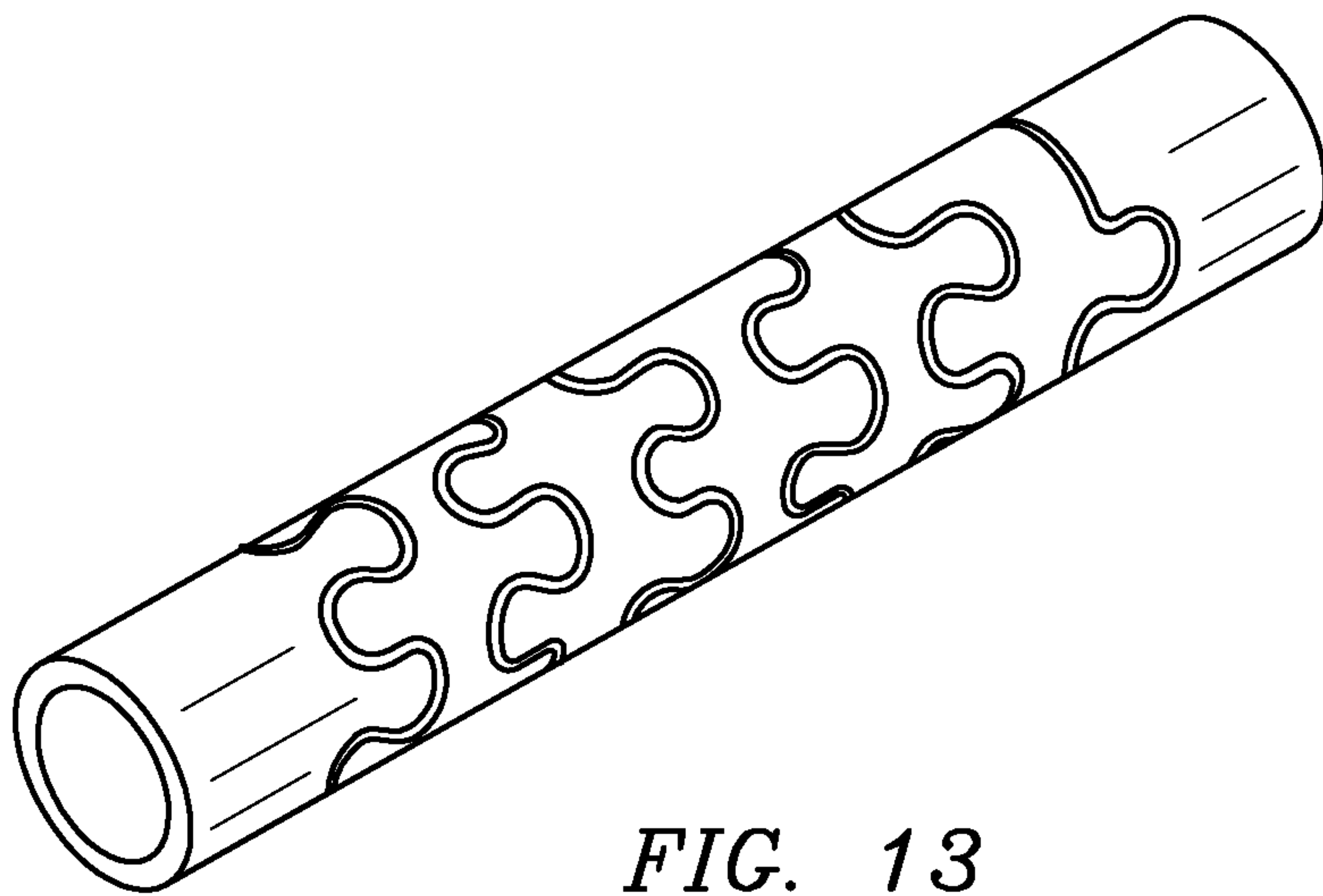

FIG. 13

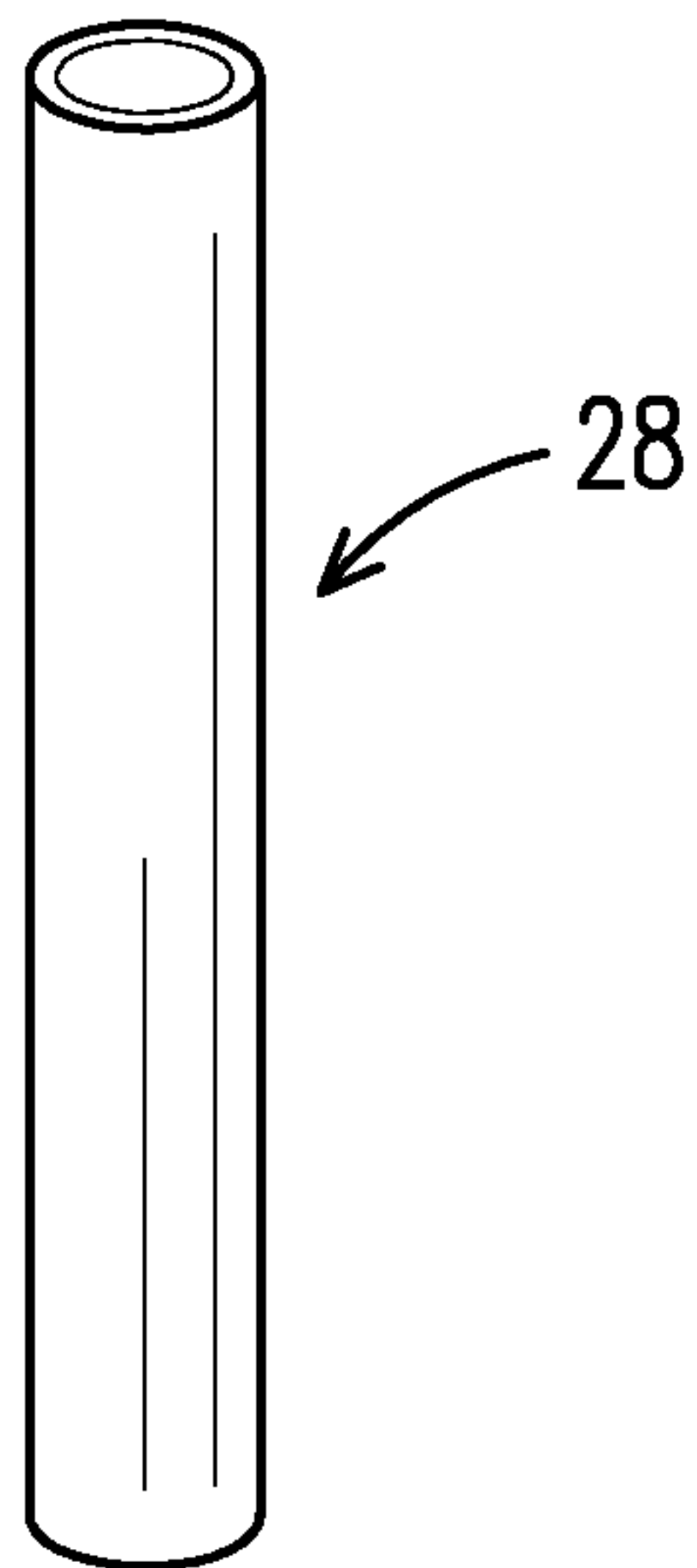

FIG. 14

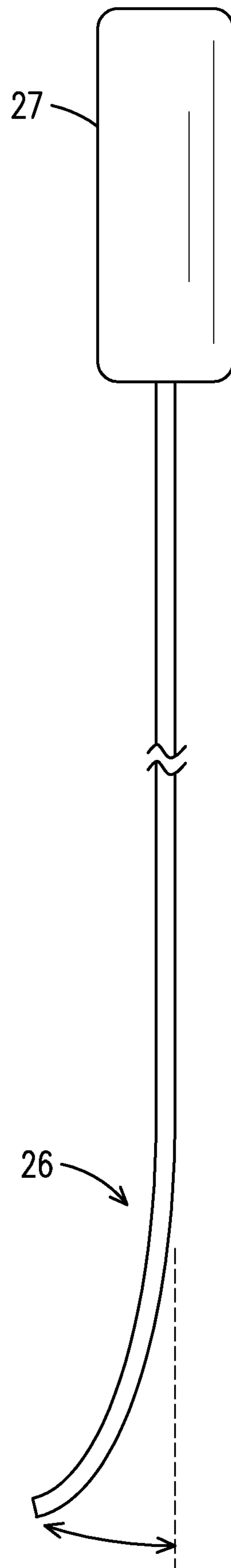

FIG. 12

