

(No Model.)

J. HOOPER.

DIE FOR LEAD PRESSES.

No. 347,607.

Patented Aug. 17, 1886.

Fig. 1.

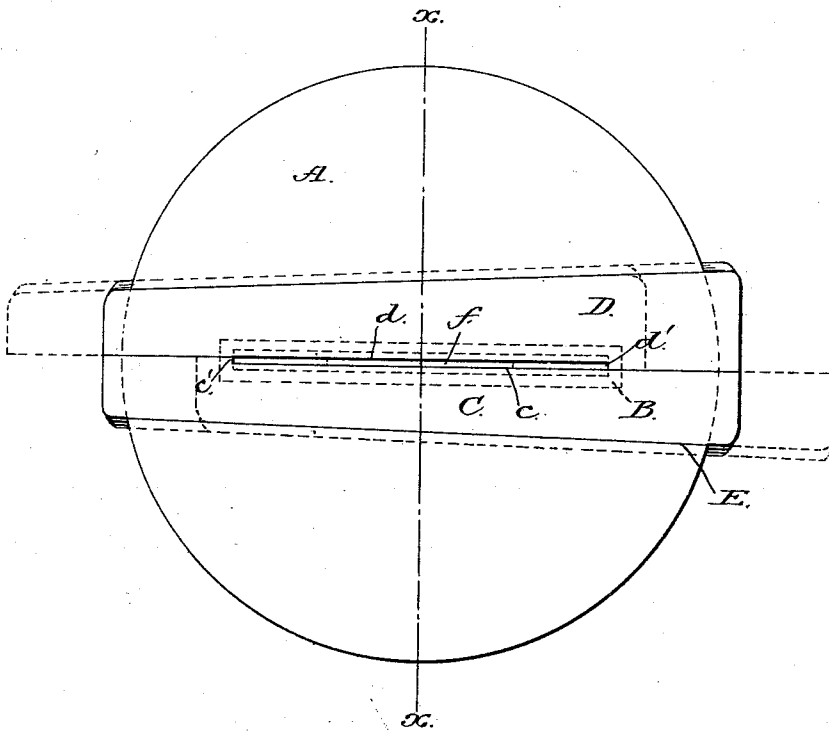

Fig. 2.

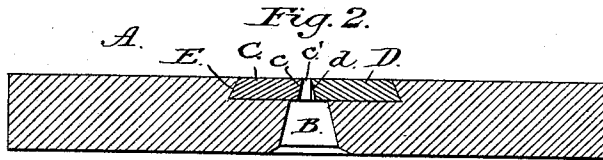
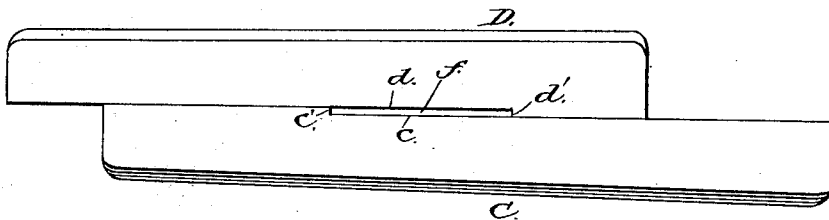

Fig. 3.



WITNESSES:

*John A. Ellis*  
*Co. Sedgwick*

INVENTOR:

*J. Hooper*  
BY *Munn & Co.*  
ATTORNEYS.

# UNITED STATES PATENT OFFICE.

JOHN HOOPER, OF NEW YORK, N. Y., ASSIGNOR TO THE COLWELL LEAD COMPANY, OF SAME PLACE.

## DIE FOR LEAD-PRESSES.

SPECIFICATION forming part of Letters Patent No. 347,607, dated August 17, 1886.

Application filed May 26, 1886. Serial No. 203,276. (No model.)

### To all whom it may concern:

Be it known that I, JOHN HOOPER, of the city, county, and State of New York, have invented a new and useful Improvement in Dies for Lead-Presses, of which the following is a full, clear, and exact description.

My invention relates to an improvement in lead-press dies for making sheet-lead; and the invention consists, principally, of a set of adjustable die plates or keys adapted to be placed in a bed-plate, both die-plates being offset at their meeting edges to form, when placed together, a narrow slot, the length of which may be increased or diminished by sliding the die-plates in opposite directions in the bed-plate, so that sheets of lead of different widths may be made with the same set of die-plates or keys, thus avoiding the necessity of having a separate die for each width of lead to be provided, as is now the practice.

The invention also consists in beveling the offset edges of the die-plates so that they will present sharp edges to the lead being forced between them to prevent warping or buckling of the sheet being formed.

Reference is to be had to the accompanying drawings, forming a part of this specification, in which similar letters of reference indicate corresponding parts in all the figures.

Figure 1 is a plan view of my new and improved lead-press die. Fig. 2 is a sectional elevation of the same, taken on the line *xx* of Fig. 1; and Fig. 3 is a plan view of the die-plates removed from the bed-plate.

A represents the bed-plate, made of metal, and preferably circular in form, and of a size adapting it to be placed in the bottom of an ordinary hydraulic lead-press. In the center of the plate A is formed an opening, B, through which the sheet of lead passes after passing between the die-plates C D, held in line with the opening B in a dovetailed recess, E, formed in the upper surface of the bed-plate A. The die-plates C D are wedge-shaped or made slightly tapering, and are beveled at their outer edges to fit the dovetailed or under-cut edges of the recess E.

The inner edge of the plate C is offset at *c*, to form the shoulder or stop *c'*. The adjacent edge of the plate D is offset at *d*, to form the shoulder or stop *d'*. The shoulders *c'* *d'*, when the plates C D are placed in the recess E, space said plates to form a slot, *f*, through which the lead is pressed and formed into sheets. The shoulders *c'* *d'* close the said slot *f* at its ends, and the shoulders being formed one on each plate, the length of the slot may be increased or diminished by moving the plates C D longitudinally, as indicated in full and dotted lines in Fig. 1, and in full lines in Fig. 3. In this manner sheets of different widths may be produced with a single set of plates C D.

The offset portions *c d* of the plates C D are beveled downward and toward the outer edges of the said plates, so the upper adjacent edges are made sharp, as shown in Fig. 2, thus causing the plates to have a cutting action upon the lead forced between them, which will prevent the sheets from warping or buckling and will give them smooth surfaces.

My new die-plates may be used in any form of press and for forming tin, zinc, lead, and other soft or composite metals into sheets.

Having thus fully described my invention, I claim as new and desire to secure by Letters Patent—

1. A die composed of a recessed and apertured bed-plate, A, and two die-plates, C D, each offset to form the slot *f*, the plate C being formed with the shoulder *c'*, the plate D with the opposing shoulder *d'*, so that by adjusting the plates C D the length of the slot may be increased or diminished, substantially as described.

2. The bed-plate A, having the opening B and tapering recess E, in combination with the die-plates C D, made tapering to fit the recess E, and formed with the shoulders *c'* and *d'*, substantially as and for the purposes set forth.

JOHN HOOPER.

Witnesses:

H. A. WEST,  
EDGAR TATE.