



(51) International Patent Classification:

D01F 6/00 (2006.01) D01F 4/00 (2006.01)
D01F 6/88 (2006.01) D01F 2/00 (2006.01)
D01F 6/44 (2006.01) D01F 9/00 (2006.01)
A61L 17/10 (2006.01)

(21) International Application Number:

PCT/IB2010/000600

(22) International Filing Date:

22 February 2010 (22.02.2010)

(25) Filing Language:

English

(26) Publication Language:

English

(30) Priority Data:

61/154,379 21 February 2009 (21.02.2009) US

(71) Applicants (for all designated States except US):

SOFRADIM PRODUCTION [FR/FR]; 116 avenue du Formans, F-01600 Trevoux (FR). TYCO HEALTH-CARE GROUP LP [US/US]; 60 Middletown Road, North Haven, CT 06473 (US).

(72) Inventors; and

(75) Inventors/Applicants (for US only): HADBA, Ahmad, Robert [US/US]; 23 High Meadow Lane, Middlefield, CT 06455 (US). LADET, Sebastien [FR/FR]; 129 avenue Thiers, F-69006 Lyon (FR).

(74) Agent: CABINET GERMAIN & MAUREAU; BP

6153, F-69466 Lyon Cedex 06 (FR).

(81) Designated States (unless otherwise indicated, for every

kind of national protection available): AE, AG, AL, AM, AO, AT, AU, AZ, BA, BB, BG, BH, BR, BW, BY, BZ, CA, CH, CL, CN, CO, CR, CU, CZ, DE, DK, DM, DO, DZ, EC, EE, EG, ES, FI, GB, GD, GE, GH, GM, GT, HN, HR, HU, ID, IL, IN, IS, JP, KE, KG, KM, KN, KP, KR, KZ, LA, LC, LK, LR, LS, LT, LU, LY, MA, MD, ME, MG, MK, MN, MW, MX, MY, MZ, NA, NG, NI, NO, NZ, OM, PE, PG, PH, PL, PT, RO, RS, RU, SC, SD, SE, SG, SK, SL, SM, ST, SV, SY, TH, TJ, TM, TN, TR, TT, TZ, UA, UG, US, UZ, VC, VN, ZA, ZM, ZW.

(84) Designated States (unless otherwise indicated, for every

kind of regional protection available): ARIPO (BW, GH, GM, KE, LS, MW, MZ, NA, SD, SL, SZ, TZ, UG, ZM, ZW), Eurasian (AM, AZ, BY, KG, KZ, MD, RU, TJ, TM), European (AT, BE, BG, CH, CY, CZ, DE, DK, EE, ES, FI, FR, GB, GR, HR, HU, IE, IS, IT, LT, LU, LV, MC, MK, MT, NL, NO, PL, PT, RO, SE, SI, SK, SM, TR), OAPI (BF, BJ, CF, CG, CI, CM, GA, GN, GQ, GW, ML, MR, NE, SN, TD, TG).

Published:

- with international search report (Art. 21(3))
- before the expiration of the time limit for amending the claims and to be republished in the event of receipt of amendments (Rule 48.2(h))

(54) Title: CROSSLINKED FIBERS AND METHOD OF MAKING SAME BY EXTRUSION

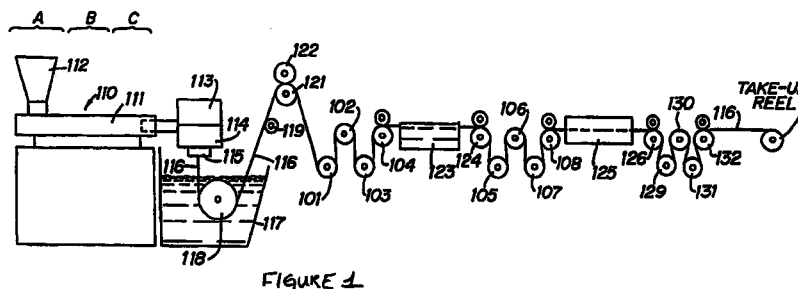

(57) Abstract: The present disclosure relates to a method of forming fibers. First and second precursors, each possessing a core and at least one functional group known to have click reactivity, are mixed. The mixed precursors are then extruded under heat to cross-link during fiber production.

WO 2010/095049 A1

**CROSSLINKED FIBERS AND
METHOD OF MAKING SAME BY EXTRUSION**

5

BACKGROUND

Technical Field

10 The present disclosure relates to crosslinked fibers, and more particularly to the use of click chemistry to form the crosslinked fibers, methods of preparing such fibers, and surgical devices made from such fibers.

Background of Related Art

15 Methods for making monofilaments that are suitable to fabricate surgical articles, such as sutures, generally include the steps of extruding at least one bioabsorbable or nonbioabsorbable polymer to provide filaments, drawing or stretching the solidified filaments to achieve molecular orientation, and annealing the drawn filaments to relieve internal stresses.

 Various spinning methods may be employed, such as melt spinning, wet or dry solvent
20 spinning, and reaction spinning. Melt spinning uses heat to melt the fiber polymer to a viscosity suitable for extrusion through the spinneret. Solvent spinning uses large amount of organic solvents to dissolve the fiber polymer into a fluid polymer solution suitable for extrusion through a spinneret. Reaction spinning involves the formation of filaments from prepolymers and monomers that are further polymerized and cross-linked after the filament is formed.

25 Click chemistry refers to a collection of reactions capable of forming a highly reliable molecular connection in solution or bulk state. Click chemistry reactions may be highly selective, high yield reactions which should not interfere with one another as well as other reactions.

It would be desirable to make filaments useful in making surgical devices by extruding a mixture containing first and second precursors functionalized for crosslinking by click chemistry and aided by the process controls of the spinning process, such as temperature, pressure, and time.

5

SUMMARY

A first aspect of the present invention is a method for forming fibers comprising:
obtaining a mixture by mixing first and second precursors each possessing a core and at least one functional group known to have click reactivity; and
10 extruding said mixture in order to crosslink the first and second precursors to produce a fiber.

In the present application, unless otherwise specified, the expressions ‘functional group’, ‘functional group known to have click reactivity’ and ‘reactive member’ are used interchangeably to designate a functional group known to have click reactivity.

15 In the present application, unless otherwise specified, the expression ‘functionalized polymer’ or ‘functionalized precursor’ means the polymer or the precursor possessing the functional group as defined herein.

Another aspect of the present invention is a fiber prepared by :

- obtaining a mixture by mixing first and second precursors each possessing a core and at
20 least one functional group known to have click reactivity; and
extruding said mixture in order to crosslink the first and second precursors to produce a fiber.

In embodiments, the first and second precursors are biocompatible polymers.

In embodiments, for each of said first and second precursors, the core comprises synthetic materials selected from poly(lactic acid), poly (glycolic acid), poly(lactide), poly(glycolide), poly(trimethylene carbonate), poly (dioxanone), poly (hydroxybutyrate), poly (phosphazine), polyesters, polyethylene terephthalate, ultra-high molecular weight polyethylene, polyethylene glycols, polyethylene oxides, polyacrylamides, polyhydroxyethylmethacrylate, polyvinylpyrrolidone, polyvinyl alcohols, polyacrylic acid, polyacetate, polycaprolactone, polypropylene, aliphatic polyesters, glycerols, poly(amino acids), copoly (ether-esters), polyalkylene oxalates, poly (saccharides), polyamides, poly (iminocarbonates), polyalkylene oxalates, polyoxaesters, polyorthoesters, polyphosphazenes, biopolymers, polymer drugs and copolymers, block copolymers, homopolymers, blends and combinations thereof.

In embodiments, for each of said first and second precursors, the core comprises natural polymers selected from collagen, cellulose, poly (amino acids), polysaccharides, chitosan and chitosan derivatives (e.g., chitosan acetate/formate polymers), hyaluronic acid, gut, copolymers and combinations thereof.

In embodiments, for each of said first and second precursors, the functional group known to have click reactivity is selected from the group consisting in amine, sulfate, thiol, hydroxyl, azide, alkyne, alkene, and carboxyl groups.

In embodiments, the functional group of the first precursor is an azide and the functional group of the second precursor is an alkyne.

In embodiments, the functional group of the first precursor is a thiol and the functional group of the second precursor is an alkene.

In embodiments, the cores of said first and second precursors being selected from chitin and chitosan, the mixture is spun from anisotropic solution of chitin or chitosan.

In embodiments, the cores of said first and second precursors being collagen, the mixture is gel spun.

In embodiments, the functional group of the first precursor has click reactivity with the functional group of the second precursor.

5 A method for forming fibers includes mixing first and second precursors each possessing a core and at least one functional group known to have click reactivity and extruding the first and second precursors under heat to crosslink the first and second precursors to produce a cross-linked fiber.

Another aspect of the invention is a method for forming fibers comprising:

10 mixing first and second precursors each possessing a core and at least one functional group known to have click reactivity; and

extruding the first and second precursors to crosslink the first and second precursors to produce a fiber.

15 Another aspect of the invention is a fiber prepared by cross-linking a mixture of a first precursor and a second precursor during extrusion, the first precursor possessing at least one functional group and the second precursor possessing a functional group having click reactivity with the first functional group.

20 **BRIEF DESCRIPTION OF THE DRAWINGS**

The accompanying drawings, which are incorporated in and constitute a part of this specification, illustrate embodiments of the disclosure and, together with a general description of

the disclosure given above, and the detailed description of the embodiments given below, serve to explain the principles of the disclosure.

FIGURE 1 is a schematic illustration of an apparatus which is suitable for carrying out a fiber manufacturing process in accordance with the present disclosure;

5 FIGURE 2 is a schematic illustration of another apparatus which is suitable for carrying out a fiber manufacturing process in accordance with the present disclosure;

FIGURE 3 is a cross-sectional view of yet another embodiment of a fiber manufacturing process; and

10 FIGURE 4 is a schematic illustration of another apparatus suitable for spinning fiber in accordance with the present disclosure.

DETAILED DESCRIPTION OF THE EMBODIMENTS

Fibers in accordance with the present disclosure are prepared by spinning or extruding a mixture of first and second precursors each having at least one functional group known to have click reactivity. Cross-linked fibers formed in accordance with the present disclosure may be made by reaction of a functionalized first precursor with a functionalized second precursor under conditions which cause the two precursors to form covalent bonds without the use of a chemical crosslinking agent or catalyst. In this respect, process controls, such as temperature, time, and pressure will aid in the cross-linking of the precursors.

20 The first and second precursors may each possess a core functionalized with one or more reactive members.

The core of the first and second precursors may be the same or different and may be any suitable biocompatible material. Thus, the fibers may be prepared from any first and second

precursors known to form biocompatible polymers. Each core may be a homopolymer or a copolymer, including random copolymer, block copolymer, or graft copolymer. In embodiments, the first and second precursors are different materials, thus forming copolymer filaments. Each core may be a linear polymer, a branched polymer, or a dendrimer. The core of the first and second precursors may be a natural material or a synthetic material and may be bioabsorbable or non-bioabsorbable. It should of course be understood that any combination of natural, synthetic, bioabsorbable and non-bioabsorbable materials may be used to form the fibers.

Some non-limiting examples of synthetic materials from which the core may be prepared include, but are not limited to poly(lactic acid), poly (glycolic acid), poly(lactide), poly(glycolide), poly(trimethylene carbonate), poly (dioxanone), poly (hydroxybutyrate), poly (phosphazine), polyesters, polyethylene terephthalate, ultra-high molecular weight polyethylene, polyethylene glycols, polyethylene oxides, polyacrylamides, polyhydroxyethylmethacrylate, polyvinylpyrrolidone, polyvinyl alcohols, polyacrylic acid, polyacetate, polycaprolactone, polypropylene, aliphatic polyesters, glycerols, poly(amino acids), copoly (ether-esters), polyalkylene oxalates, poly (saccharides), polyamides, poly (iminocarbonates), polyalkylene oxalates, polyoxaesters, polyorthoesters, polyphosphazenes, biopolymers, polymer drugs and copolymers, block copolymers, homopolymers, blends and combinations thereof. Suitable natural polymers from which the core may be prepared include collagen, cellulose, poly (amino acids), polysaccharides, chitosan and chitosan derivatives (e.g., chitosan acetate/formate polymers), hyaluronic acid, gut, copolymers and combinations thereof.

In preparing fibers in accordance with the present disclosure, the first and second precursors may be commercially available pre-functionalized cores or may be synthesized.

With respect to each core, it is contemplated that a plurality of first reactive members may be present and that they may be terminally located, or alternatively located along the length of the polymer chain. In embodiments, the precursors have from about 2 to about 50 reactive members.

5 Examples of the types of reactions that are known to have click reactivity include cycloaddition reactions. Cycloaddition reactions can be used to form the fibers of the present disclosure. These reactions represent highly specific reactant pairs that have a chemoselective nature, meaning that they mainly react with each other and not other functional groups. One example of a cycloaddition reaction is the Huisgen 1,3-dipolar cycloaddition of a dipolarophile
10 with a 1,3 dipolar component that produce five membered (hetero)cycles. Examples of dipolarophiles are alkenes, alkynes, and molecules that possess related heteroatom functional groups, such as carbonyls and nitriles. Specifically, another example is the 2+3 cycloaddition of alkyl azides and acetylenes. Other cycloaddition reactions include Diels-Alder reactions of a conjugated diene and a dienophile (such as an alkyne or alkene).

15 Other examples of the types of reactions that are known to have click reactivity include a hydrosilation reaction of H-Si and simple non-activated vinyl compounds, urethane formation from alcohols and isocyanates, Menshutkin reactions of tertiary amines with alkyl iodides or alkyl trifluoromethanesulfonates, Michael additions, e.g., the very efficient maleimide-thiol reaction, atom transfer radical addition reactions between $-\text{SO}_2\text{Cl}$ and an olefin ($\text{R}^1, \text{R}^2\text{-C}=\text{C-}$
20 R^3, R^4), metathesis, Staudinger reaction of phosphines with alkyl azides, oxidative coupling of thiols, many of the procedures already used in dendrimer synthesis, especially in a convergent approach, which require high selectivity and rates, nucleophilic substitution, especially of small strained rings like epoxy and aziridine compounds, carbonyl chemistry like formation of ureas,

and addition reactions to carbon-carbon double bonds like dihydroxylation. Therefore, attached functionality may be chosen from acetylene bond, an azido-group, a nitrile group, acetylenic, amino group, phosphino group. The click chemistry reaction may results in the addition of a functional group selected from amino, primary amino, hydroxyl, sulfonate, benzotriazole, bromide, chloride, chloroformate, trimethylsilane, phosphonium bromide or bio-responsive functional group including polypeptides, proteins and nucleic acids, to the polymer.

Thus, suitable reactive members that may be applied to the core include, for example, an amine, sulfate, thiol, hydroxyl, azide, alkyne, alkene, and carboxyl groups. The reactive member may be a thiol. Alternatively, the reactive member may be an azide. Alternatively, the reactive member may be an alkyne. Alternatively, the reactive member may be an alkene.

The core of the first and second precursor can be provided with click reactive members using any variety of suitable chemical processes.

For example, the monomers from which the core is made can be functionalized so that the reactive members appear along the length of the core. In such embodiments, monomers can be initially functionalized with a group such as a halogen to provide a reactive site at which the desired first click reactive member can be attached after polymerization. Thus, for example, a cyclic lactone (e.g., glycolide, lactide, caprolactone, etc.) can be halogenated and then polymerized using known techniques for ring opening polymerization. Once polymerized, the halogenated sites along the resulting polyester chain can be functionalized with a click reactive member, for example, by converting pendant chlorides on the core into azides by reaction with sodium azide. See, R. Riva et al., *Polymer* 49, pages 2023–2028 (2008) for a description of such reaction schemes. Other methods for functionalizing lactones are described in Jérôme et al.,

Advanced Drug Delivery Reviews, 60, pages 1056–1076 (2008) and Shi et al., *Biomaterials*, 29, pages 1118–1126 (2008). The entire disclosure of each of these three articles is incorporated herein by this reference.

Where one of the precursors includes a core that is an amino-containing material (e.g., collagen, polypeptide, glycosaminoglycan, etc.), the core of the second precursor can be functionalized by using any method known to those skilled in the art to provide pendant portions of the core with moieties which are capable of covalently bonding with the amino groups on the first precursor. Examples of such pendant moieties, corresponding to the functional groups as defined herein, include aldehyde groups, sulfone groups, vinylsulfone groups, isocyanate groups, acid anhydride groups, epoxide groups, aziridine groups and episulfide groups. In addition, electrophilic groups such as $-\text{CO}_2\text{N}(\text{COCH}_2)_2$, $-\text{CO}_2\text{N}(\text{COCH}_2)_2$, $-\text{CO}_2\text{H}$, $-\text{CHO}$, $-\text{CHOCH}_2$, $-\text{N}=\text{C}=\text{O}$, $-\text{SO}_2\text{CH}=\text{CH}_2$, $-\text{N}(\text{COCH})_2$, $-\text{S}-\text{S}-(\text{C}_5\text{H}_4\text{N})$ may also be added to pendant chains of the core to allow covalent bonding to occur with the any cores showing amino group on their chains. Other suitable functional groups which may be added to the core include groups of the following structures wherein X is Halogen and R is hydrogen or C_1 to C_4 alkyl:

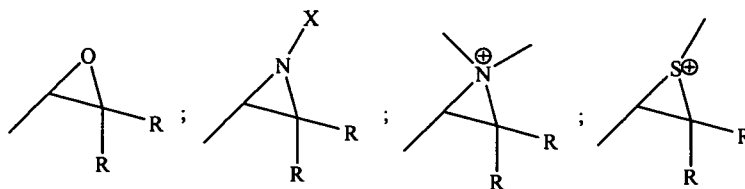

Those skilled in the art reading this disclosure will readily envision chemical reactions for activating other core materials to render them suitable for use as precursors in the presently described methods.

The first and second precursors may take the form of any solution, suspension, semi-solid, or solid material capable of allowing the two components to interact and crosslink during extrusion. The first and second precursors may be in granular, pellet, or powder form, or alternatively, may be in a dilute solution. Suitable solvents which may be utilized to form a dilute solution include any biocompatible solvent within the purview of those skilled in the art which will not interfere with the reaction of the reactive members of the first and second precursors. Suitable solvents which may be utilized include, for example, polar solvents such as water, ethanol, triethylene glycol, dimethyl sulfoxide, glymes (such as diglyme, triglyme, tetraglyme, and the like), polyethylene glycols, methoxy-polyethylene glycols, dimethylformamide, dimethylacetamide, gamma-butyrolactone, n-methylpyrrolidone, ketones such as methyl ethyl ketone, cyclohexanone, diethylene glycol monomethyl ether acetate, diethylene glycol monobutyl ether acetate, diethylene glycol monomethyl ether, diethylene glycol monoethyl ether, diethylene glycol monobutyl ether, diethylene glycol monoisobutyl ether, diisobutyl ketone, diacetone alcohol, ethyl amyl ketone, ethyl lactate, and the like. In other embodiments, solvents such as tetrahydrofuran, ethyl acetate, isopropyl acetate, butyl acetate, isopropanol, butanol, acetone, and the like, may be utilized. In embodiments, combinations of any of the foregoing solvents may be utilized to form a dilute solution. The amount of solvent used will depend on a number of factors, including the particular first precursor, second precursor, or combination thereof that are to be employed and the intended end use of the composition.

The first and second precursors may be placed in a hopper and mixed thoroughly to provide substantially uniform distribution of the first precursor among the second precursor. The first and second precursors may be mixed using any conventional technique, with or without

heating. For example, a mechanical mixer, a static mixer, or combinations thereof, may be employed to assist in providing a substantially uniform distribution of first and second precursors. After mixing, the mixture is extruded or spun to form one or more filaments or fibers.

5 The rate of cross-linking of the first and second precursors of the present disclosure may be tailored by controlling the concentration of the first precursor and the second precursor. Generally, a faster cross-link time may be observed at a higher concentration of either the first or second precursors than the rate observed for the same components at a lower concentration. In
10 embodiments, the ratio of first precursor reactive members to second precursor reactive members is from about 1:2 to about 1:1.

 Known spinning apparatuses can be used for the production of filaments, in accordance with the present disclosure. FIG. 1 schematically illustrates a filament manufacturing operation in accordance with the disclosure. Extruder unit 110 is of a known or conventional types and is equipped with controls for regulating the temperature of barrel 111 in various zones thereof, e.g.,
15 progressively higher temperatures in three consecutive zones, A, B, and C along the length of the barrel. The first and second precursors to be spun into filaments are introduced to the extruder through hopper 112. Prior to or during placement in hopper 112, the first precursor is combined with the second precursor and mixed in a one-pot process. Adding heat during the mixing and/or extruding steps aids in the curing time of the first and second precursors, as faster curing rates
20 are observed at higher temperatures.

 Motor-driven metering pump 113 delivers the melt extruded first and second precursor mixture at a constant rate and with high pressure to spin pack 114 and thereafter through spinneret 115 possessing one or more orifices of desired diameter to provide a molten

monofilament 116 which then enters quench bath 117, e.g., containing water, where the monofilament solidifies. The distance monofilament 116 travels after emerging from spinneret 115 to the point where it enters quench bath 117, i.e., the air gap, can vary. If desired, a chimney (not shown), or shield, can be provided to isolate monofilament 116 from contact with air currents which might otherwise affect the cooling of the monofilament in an unpredictable manner. In general, barrel zone A of the extruder can be maintained at a temperature of from about 100°C to 220°C, zone B at from about 160°C to 230°C and zone C at from about 170°C to about 240°C. Additional temperature parameters include: metering pump block 113 at from about 170°C to about 230°C, spin pack 114 at from about 170°C to about 230°C, spinneret 115 at from about 170°C to about 230°C and quench bath at from about 10°C to about 80°C.

Monofilament 116 is passed through quench bath 117 around driven roller 118 and over idle roller 119. Optionally, a wiper (not shown) may remove excess water from the monofilament as it is removed from quench bath 117. On exiting the quench bath the monofilament is wrapped around a first godet 121 provided with nip roll 122 to prevent slippage which might otherwise result from the subsequent stretching operation; and subsequently wrapped around godets 101, 102, 103 and 104 or any other suitable godet arrangement. Monofilament 116 passing from godet 104 is stretched, e.g., with stretch ratios on the order of from about 3:1 to about 10:1 and preferably from about 4:1 to about 7:1, to effect its orientation and thereby increase its tensile strength.

In the stretching operation, monofilament 116 may be drawn through hot water (or other suitable liquid medium) draw bath 123 by means of godets 124, 105, 106, 107 and 108 or any other suitable arrangement of godets which rotate at a higher speed than godet 104 to provide the desired stretch ratio. The temperature of hot water draw bath 123 is advantageously from about

30°C to about 90°C and preferably is from about 30°C to about 50°C. In an alternative stretching operation, generally preferred for smaller sutures sizes, e.g., sizes 3/0 to 8/0, monofilament 116 may be drawn by godets 124, 105, 106, 107, and 108 or any other suitable godet arrangement through hot air convection oven chamber 123 at a temperature of from about 5 30°C to about 140°C, and preferably from about 50°C to about 130°C to provide the desired amount of stretch.

Following the stretching operation, monofilament 116 optionally may be subjected to an on-line annealing and/or additional stretching without shrinkage or relaxation with shrinkage operation as a result of which the monofilament shrinks. In the process of FIG. 1, on-line 10 annealing with or without relaxation when desired is accomplished by driving monofilament 116 by godets 126, 129, 130, 131, and 132 or any other suitable godet arrangement through second hot air oven chamber 125 at a temperature of from about 40°C to about 150°C, and preferably from about 60°C to about 130°C. During the relaxation process, at these temperatures, monofilament 116 will generally recover to within about 80 to about 97 percent, and preferably 15 to within about 95 percent, of its pre-annealed length to provide the finished suture. For relaxation, the third godet rotates at a slower speed than the second godet thus relieving tension on the filament.

Annealing of the suture also may be accomplished without shrinkage of the suture. In carrying out the annealing operation, the desired length of suture may be wound around a creel 20 and the creel placed in a heating cabinet maintained at the desired temperature, e.g. about 60°C to about 130°C. After a suitable period of residency in the heating cabinet, e.g., about 18 hours or so, the suture will have undergone essentially no shrinkage. Variables such as the annealing temperatures, time, and pressure may affect the curing time of the fibers as well. The creel may

be rotated within the heating cabinet in order to insure uniform heating of the monofilament or the cabinet may be of the circulating hot air type in which case uniform heating of the monofilament will be achieved without the need to rotate the creel. Thereafter, the creel with its annealed suture is removed from the heating cabinet and when returned to room temperature, the suture is removed from the creel, conveniently by cutting the wound monofilament at opposite ends of the creel. The annealed sutures are then ready to be packaged and sterilized.

In embodiments, cross-linked fibers from chitin or chitin derivative cores that have been functionalized with click reactive members can be produced according to the present disclosure by spinning from anisotropic solution. Suitable methods for solution spinning chitin or chitin derivative fibers in general are disclosed in European Patent Nos. EP0328050A2 and EP0077098A2, the entire disclosures of which are incorporated herein by this reference. Such fibers can have tensile properties which typically fall between 4-8 g/d tenacity and 150-250 g/d initial modulus.

High strength chitosan fibers can be prepared by spinning an anisotropic solution of chitosan or a derivative of chitin or chitosan through an inert gas and into a coagulating bath, removing the as-spun fiber and treating it with alkali to remove N-acetyl, O-acetyl or other pendant groups at the 2, 3 and 6 carbon positions of the glucosamine repeating unit. Treatment of fibers is by immersion of the fibers into a solution of NaOH. With fine denier fibers, e.g., 4-5 dpf., a 5 minute immersion at 70° C. in a 50% wt. solution of NaOH is satisfactory. A 2-3 hr. exposure at 80° C. in a 30% wt. solution is useful with chitosan acetate formate fiber. With chitosan acetate, temperatures in the range of 80° to 116° C. at NaOH concentration of 30% have been found useful with the higher temperatures requiring less time for completion of the reaction. Severe treatments are generally to be avoided since they may cause excessive

interfilament fusion and a product of inferior quality. Conversion of the starting fiber to a chitosan fiber is confirmed if the chitosan fiber is readily soluble in dilute (3-20% wt.) acetic acid.

In using the apparatus of FIG. 2 an anisotropic solution of chitin or a chitin derivative is placed in spin cell (G). A piston (D) activated by hydraulic press (F) and associated with piston travel indicator (E) is positioned over the surface of the solution, excess air is expelled from the top of the cell and the cell is sealed. The spin cell is fitted at the bottom with the following screens (A) for solution filtration: four to six 325-mesh screens. The filtered solution is then passed into a spinneret pack (B) containing two or three 325-mesh screens. Solutions are extruded through an air gap at a controlled rate into a static bath (C) using a metering pump to supply pressure at piston (D). The fiber is passed around a pin (H), pulled through the bath, passed under a second pin (I) and wound onto a bobbin. The air gap between the spinneret face and the coagulation bath is typically 0.6 to 2.0 cm. The coagulation bath temperature is generally held below 100° C.

In using the apparatus of FIG. 3, filter plate (J) is replaced by mixing plate (R). Polymer dope is placed in cylinder bore (T) and then piston (D) and cap plate (L) is fitted to the spin cell (G). A driver fluid (e.g. water) is pumped into the upper part of bore (T) through feed line (F). The piston (D) is displaced by the driver fluid, thereby pushing the polymer dope through passages (W), (S) in mixing plate (R) and then through passage (K) in distribution plate (M) into second cylinder bore (U). This process is then reversed by pumping fluid through feed line (X). The aforementioned forward and reverse process is repeated several times to effect a mixing of the polymer dope. Component (E) acts to sense the position of cylinder (D).

After mixing is complete (about 30 cycles), mixing plate (R) is replaced by filter plate (J)

and polymer dope is extruded from bore (T) through passage (W), through filter pack (A) containing 2 Dutch Twill Weave 165×800 mesh screens, through passage (Y) in filter plate (J) and passage (Z) in spinneret mounting plate (O) and out of spin cell (G) through spinneret (B). The extruded dope is spun into a bath and taken up as described for FIG. 2. Pressure of the
5 polymer dope during spinning is measured by pressure transducer (P).

In other embodiments, cross-linked fibers from collagen or collagen derivative cores that have been functionalized with click reactive members can be produced according to the present disclosure by gel spinning. Suitable methods for gel spinning collagen fibers in general are disclosed in U.S. Patent Nos. 5,562,946 and 5,911,942, the entire disclosures of which are
10 incorporated herein by this reference.

In an illustrative apparatus for gel spinning such fibers shown in Fig. 4, collagen reservoir chamber 10 holds a liquid collagen solution. In one embodiment, a suitable chamber is a stainless steel syringe. Reservoir tube 12 is attached to collagen reservoir chamber 10 for directing collagen solution from collagen reservoir chamber 10 through infusion pump 14 to
15 spinneret 16. Infusion pump 14 is capable of raising the pressure of the collagen material such that it can be extruded through spinneret nozzle 17 of spinneret 16. In embodiments, a positive displacement metering pump is used. Spinneret 16 can be single bore or multiple bore to produce monofilament or multifilament fibers respectively. The spinneret bores can be of various
20 diameters or have tapered profiles to form fibers of different sizes and tensile strengths. Co-component fibers can be produced with other specialized spinnerets as are known in the art. In one embodiment, spinneret nozzle 17 has diameters in the range of between about 100 and 1,000 microns.

Coagulation bath 18 has a coagulation solution 20 that can cause the liquid collagen to form a collagen gel, such as a 0.75% alkaline alginic acid in a boric acid buffer or sugar solutions or polyethylene glycol solution which also has hydrophilic properties. The opening of spinneret is immersed in a flowing coagulation solution 20. Coagulation bath 18 is suitably sized for
5 allowing extrusion of fiber from spinneret 16 through coagulation solution 20 while having a sufficient residency time for collagen gel fiber 22 to form. Coagulation bath 18 can be heated and instrumented for monitoring the relevant process variables, such as temperature, pH and velocity. Coagulation bath 18 allows collagen gel fiber 22 to be formed in a horizontal trough or in a tube or vertically in a tube. Coagulation bath 18 is configured to allow circulation of
10 coagulation solution 20 through recirculating loop 26 by circulating pump 28. Coagulation bath flow can be in the same direction 30 of fiber travel. At the end of the coagulation bath 18, roller 32 is for directing fiber out of the coagulation bath. Roller 32 is motorized and can be activated to wind collagen gel fiber 22 and subsequently tow collagen gel fiber 22 at desired speeds.

Dehydrating bath 34 is adjacent to roller 32 and coagulation bath 18 and is configured to
15 allow fiber 22 to be drawn into dehydrating bath 34 from roller 32. Dehydrating bath 34 holds dehydrating solution 36, such as 90% ethanol, which allows further dehydration and annealing of the fiber and promotes polymerization of the collagen to improve fiber strength. An example of another suitable dehydration solution composition is acetone. Dehydrating bath 34 is configured to allow variable circulation of dehydrating solution 36 through recirculating loop 38 by
20 circulating pump 40 which can be adjusted directionally, such as direction 41 or in the opposite direction. Return rollers 42, which can be near each end of dehydrating bath 34, allow the fiber path to be lengthened by doubling back to make any number of multiple passes through dehydrating bath 34 to allow further dehydration and promote polymerization of the collagen.

Partially dehydrated fiber 44 is wound around roller 46 to second roller 50 and then to stretching roller means 62, wherein the fiber can undergo a controlled deformation by being stretched between two groups of rollers 64 rotating at slightly different rates of speed. The speed of rotation of rollers 64 can be precisely controlled with digital microprocessors arranged in a closed feedback loop. The fibers are wrapped around each roller 64 several times to prevent fiber slippage relative to the roller surfaces. Roller 64 surfaces can be made of a polymer or a hardened metal resistant to corrosion. Roller 64 rotations can be adjusted individually to allow the fiber to be stretched beyond the elastic yield point to produce a longer fiber of reduced diameter. Stretching roller means 62 can operate under semi-dry or dry conditions and also under high moisture content atmosphere.

Drying cabinet 68 has opening 73 for receiving stretched fiber 70 from stretching rollers 62. Drying cabinet 68 has passage 71 through drying cabinet 68 for receiving warm, dry filtered air or a dry inert gas, such as dry nitrogen gas, from gas source 72 at a suitable temperature and humidity for drying stretched fiber 70. The air can be passed through air passage opening 77 into passage 71 and exiting from air passage opening 79. In embodiments, the temperature of the air is between about 35° C. and 39° C. The humidity is in the range of between 10 and 20 percent relative humidity. Drying cabinet 68 has a series of rollers 74 which allows stretched fiber 70 to remain in drying cabinet 68 while being rolled, thereby increasing the residence time of fiber 70 in drying cabinet 68. Drying cabinet rollers 74 are adjustable in distance between each other and to compensate for the fiber line speed. Drying cabinet rollers 74 can be driven at a surface roller speed that can be synchronized with that of stretching roller means 62. Drying cabinet 68 has a door to provide access to the rollers for threading the leader thread.

Take-up winder 76 is for receiving dried fiber 78 from exit 75 of drying cabinet 68. Take-up winder 76 has spool 80 for receiving dried fiber on a removable spindle bobbin. Take-up winder 76 has a slip clutch 82 to provide a constant fiber line tension and fiber line speed as the spooled fiber rotates radially around spool 80. Fiber spool 80 can wind the fiber level or by
5 randomly winding with the take-up winder 76.

Fibers formed in accordance with the present invention may be used for a variety of surgical and wound applications. The fibers, for example, may be used alone, such as for example, for closing wounds and incisions in the form of monofilament or multifilament sutures. Multifilament sutures may be constructed using any technique within the purview of those
10 skilled in the art, such as spinning and braiding the fibers together. The fibers may also be used in combination with the other absorbable or non-absorbable fibers to form multifilament sutures or to form knitted, woven, or non-woven meshes or fabrics. A wide variety of surgical articles can be manufactured from the fibers of the present disclosure. These include but are not limited to sutures as discussed above, threads, rods, filaments, yarns, meshes, slings, patches, wound
15 dressings, drug delivery devices, fasteners, and other implants and composite materials, such as pledgets, buttresses, adhesion barriers, and the like.

The fibers may further be use for delivery of a bioactive agent. Thus, in some embodiments, at least one bioactive agent may be combined with either the first precursor or the second precursor and/or may be separately applied to finished fiber. The agents may be freely
20 admixed with the precursors (making sure not reactive with them) or may be tethered to the precursors through any variety of chemical bonds. In these embodiments, the present fibers can also serve as a vehicle for delivery of the bioactive agent. The term "bioactive agent", as used herein, is used in its broadest sense and includes any substance or mixture of substances that

have clinical use. Consequently, bioactive agents may or may not have pharmacological activity per se, e.g., a dye, or fragrance. Alternatively a bioactive agent could be any agent which provides a therapeutic or prophylactic effect, a compound that affects or participates in tissue growth, cell growth, cell differentiation, an anti-adhesive compound, a compound that may be able to invoke a biological action such as an immune response, or could play any other role in one or more biological processes. It is envisioned that the bioactive agent may be applied to the present fiber in any suitable form of matter, e.g., films, powders, liquids, gels and the like.

Examples of classes of bioactive agents which may be utilized in accordance with the present disclosure include anti-adhesives, antimicrobials, analgesics, antipyretics, anesthetics, antiepileptics, antihistamines, anti-inflammatory, cardiovascular drugs, diagnostic agents, sympathomimetics, cholinomimetics, antimuscarinics, antispasmodics, hormones, growth factors, muscle relaxants, adrenergic neuron blockers, antineoplastics, immunogenic agents, immunosuppressants, gastrointestinal drugs, diuretics, steroids, lipids, lipopolysaccharides, polysaccharides, platelet activating drugs, clotting factors and enzymes. It is also intended that combinations of bioactive agents may be used.

Anti-adhesive agents can be used to prevent adhesions from forming between the implantable medical device and the surrounding tissues opposite the target tissue. In addition, anti-adhesive agents may be used to prevent adhesions from forming between the coated implantable medical device and the packaging material. Some examples of these agents include, but are not limited to hydrophilic polymers such as poly(vinyl pyrrolidone), carboxymethyl cellulose, hyaluronic acid, polyethylene oxide, poly vinyl alcohols, and combinations thereof.

Suitable antimicrobial agents which may be included as a bioactive agent in the bioactive coating of the present disclosure include triclosan, also known as 2,4,4'-trichloro-2'-

hydroxydiphenyl ether, chlorhexidine and its salts, including chlorhexidine acetate, chlorhexidine gluconate, chlorhexidine hydrochloride, and chlorhexidine sulfate, silver and its salts, including silver acetate, silver benzoate, silver carbonate, silver citrate, silver iodate, silver iodide, silver lactate, silver laurate, silver nitrate, silver oxide, silver palmitate, silver protein, and
5 silver sulfadiazine, polymyxin, tetracycline, aminoglycosides, such as tobramycin and gentamicin, rifampicin, bacitracin, neomycin, chloramphenicol, miconazole, quinolones such as oxolinic acid, norfloxacin, nalidixic acid, pefloxacin, enoxacin and ciprofloxacin, penicillins such as oxacillin and piperacil, nonoxynol 9, fusidic acid, cephalosporins, and combinations thereof. In addition, antimicrobial proteins and peptides such as bovine lactoferrin and
10 lactoferricin B may be included as a bioactive agent in the bioactive coating of the present disclosure.

Other bioactive agents which may be included as a bioactive agent in the coating composition applied in accordance with the present disclosure include: local anesthetics; non-steroidal antifertility agents; parasympathomimetic agents; psychotherapeutic agents;
15 tranquilizers; decongestants; sedative hypnotics; steroids; sulfonamides; sympathomimetic agents; vaccines; vitamins; antimalarials; anti-migraine agents; anti-parkinson agents such as L-dopa; anti-spasmodics; anticholinergic agents (e.g. oxybutynin); antitussives; bronchodilators; cardiovascular agents such as coronary vasodilators and nitroglycerin; alkaloids; analgesics; narcotics such as codeine, dihydrocodeinone, meperidine, morphine and the like; non-narcotics
20 such as salicylates, aspirin, acetaminophen, d-propoxyphene and the like; opioid receptor antagonists, such as naltrexone and naloxone; anti-cancer agents; anti-convulsants; anti-emetics; antihistamines; anti-inflammatory agents such as hormonal agents, hydrocortisone, prednisolone, prednisone, non-hormonal agents, allopurinol, indomethacin, phenylbutazone and the like;

prostaglandins and cytotoxic drugs; chemotherapeutics, estrogens; antibacterials; antibiotics; anti-fungals; anti-virals; anticoagulants; anticonvulsants; antidepressants; antihistamines; and immunological agents.

Other examples of suitable bioactive agents which may be included in the coating composition include viruses and cells, peptides, polypeptides and proteins, analogs, muteins, and active fragments thereof, such as immunoglobulins, antibodies, cytokines (e.g. lymphokines, monokines, chemokines), blood clotting factors, hemopoietic factors, interleukins (IL-2, IL-3, IL-4, IL-6), interferons (β -IFN, (α -IFN and γ -IFN), erythropoietin, nucleases, tumor necrosis factor, colony stimulating factors (e.g., GCSF, GM-CSF, MCSF), insulin, anti-tumor agents and tumor suppressors, blood proteins, fibrin, thrombin, fibrinogen, synthetic thrombin, synthetic fibrin, synthetic fibrinogen, gonadotropins (e.g., FSH, LH, CG, etc.), hormones and hormone analogs (e.g., growth hormone), vaccines (e.g., tumoral, bacterial and viral antigens); somatostatin; antigens; blood coagulation factors; growth factors (e.g., nerve growth factor, insulin-like growth factor); bone morphogenic proteins, TGF-B, protein inhibitors, protein antagonists, and protein agonists; nucleic acids, such as antisense molecules, DNA, RNA, RNAi; oligonucleotides; polynucleotides; and ribozymes.

Devices formed with the fibers of the present disclosure, such as a mesh, may be at least partially coated with a bioresorbable coating by a surface treatment for enhanced properties. For example, the coating may be collagen, chitosan, polysaccharides, or mixtures thereof. The polysaccharides may be hyaluronic acid, alginic acid, polyglucuronic acid, chitosan, starch, soluble cellulose derivatives, and mixtures thereof. Such a coating makes it possible to eliminate crevices which may form during the construction and interplay of the fibers where bacteria or inflammatory cells may develop, thus making it possible to reduce the risk of inflammation and

sepsis by preventing the installation of undesirable bacteria and/or microorganisms and/or inflammatory cells into the filled or covered crevices.

While several embodiments of the disclosure have been described, it is not intended that the disclosure be limited thereto, as it is intended that the disclosure be as broad in scope
5 as the art will allow and that the specification be read likewise. Therefore, the above description should not be construed as limiting, but merely as exemplifications of embodiments. Those skilled in the art will envision other modifications within the scope and spirit of the claims appended hereto.

WHAT IS CLAIMED IS:

1. A method for forming fibers comprising:
obtaining a mixture by mixing first and second precursors each possessing a core
and at least one functional group known to have click reactivity; and
5 extruding said mixture to crosslink the first and second precursors to produce a
fiber.
2. The method of claim 1, wherein the first and second precursors are biocompatible polymers.
- 10 3. The method of claim 1 or 2, wherein, for each of said first and second precursors, the core
comprises synthetic materials selected from poly(lactic acid), poly (glycolic acid), poly(lactide),
poly(glycolide), poly(trimethylene carbonate), poly (dioxanone), poly (hydroxybutyrate), poly
(phosphazine), polyesters, polyethylene terephthalate, ultra-high molecular weight polyethylene,
polyethylene glycols, polyethylene oxides, polyacrylamides, polyhydroxyethylmethacrylate,
15 polyvinylpyrrolidone, polyvinyl alcohols, polyacrylic acid, polyacetate, polycaprolactone,
polypropylene, aliphatic polyesters, glycerols, poly(amino acids), copoly (ether-esters),
polyalkylene oxalates, poly (saccharides), polyamides, poly (iminocarbonates), polyalkylene
oxalates, polyoxaesters, polyorthoesters, polyphosphazenes, biopolymers, polymer drugs and
copolymers, block copolymers, homopolymers, blends and combinations thereof.
- 20 4. The method of claim 1 or 2, wherein for each of said first and second precursors, the core
comprises natural polymers selected from collagen, cellulose, poly (amino acids),

polysaccharides, chitosan and chitosan derivatives (e.g., chitosan acetate/formate polymers), hyaluronic acid, gut, copolymers and combinations thereof.

5 5. The method of any one of claims 1 to 4, wherein, for each of said first and second precursors, the functional group known to have click reactivity is selected from the group consisting in amine, sulfate, thiol, hydroxyl, azide, alkyne, alkene, and carboxyl groups.

6. The method of claim 5, wherein the functional group of the first precursor is an azide and the functional group of the second precursor is an alkyne.

10

7. The method of claim 5, wherein the functional group of the first precursor is a thiol and the functional group of the second precursor is an alkene.

8. The method according to any one of claims 1 and 5 to 7, wherein the cores of said first and second precursors being selected from chitin and chitosan, the mixture is spun from anisotropic solution of chitin or chitosan.

15

9. The method according to any one of claims 1 and 5 to 7, wherein the cores of said first and second precursors being collagen, the mixture is gel spun.

20 10. The method of any one of claims 1 to 9, wherein the functional group of the first precursor has click reactivity with the functional group of the second precursor.

11. A fiber prepared by :

- obtaining a mixture by mixing first and second precursors each possessing a core and at least one functional group known to have click reactivity; and

extruding said mixture in order to crosslink the first and second precursors to produce a fiber.

5

12. The fiber of claim 11, wherein the first and second precursors are biocompatible polymers.

13. The fiber of claim 11 or 12, wherein, for each of said first and second precursors, the core comprises synthetic materials selected from poly(lactic acid), poly (glycolic acid), poly(lactide),
10 poly(glycolide), poly(trimethylene carbonate), poly (dioxanone), poly (hydroxybutyrate), poly (phosphazine), polyesters, polyethylene terephthalate, ultra-high molecular weight polyethylene, polyethylene glycols, polyethylene oxides, polyacrylamides, polyhydroxyethylmethacrylate, polyvinylpyrrolidone, polyvinyl alcohols, polyacrylic acid, polyacetate, polycaprolactone, polypropylene, aliphatic polyesters, glycerols, poly(amino acids), copoly (ether-esters),
15 polyalkylene oxalates, poly (saccharides), polyamides, poly (iminocarbonates), polyalkylene oxalates, polyoxaesters, polyorthoesters, polyphosphazenes, biopolymers, polymer drugs and copolymers, block copolymers, homopolymers, blends and combinations thereof.

14. The fiber of claim 11 or 12, wherein for each of said first and second precursors, the core
20 comprises natural polymers selected from collagen, cellulose, poly (amino acids), polysaccharides, chitosan and chitosan derivatives (e.g., chitosan acetate/formate polymers), hyaluronic acid, gut, copolymers and combinations thereof.

15. The fiber of any one of claims 11 to 14, wherein, for each of said first and second precursors, the functional group known to have click reactivity is selected from the group consisting in amine, sulfate, thiol, hydroxyl, azide, alkyne, alkene, and carboxyl groups.

5 16. The fiber of claim 15, wherein the functional group of the first precursor is an azide and the functional group of the second precursor is an alkyne.

17. The fiber of claim 15, wherein the functional group of the first precursor is a thiol and the functional group of the second precursor is an alkene.

10

18. The fiber according to any one of claims 11 and 15 to 17, wherein the cores of said first and second precursors being selected from chitin and chitosan, the mixture is spun from anisotropic solution of chitin or chitosan.

15 19. The fiber according to any one of claims 11 and 15 to 17, wherein the cores of said first and second precursors being collagen, the mixture is gel spun.

20. The method of any one of claims 11 to 19, wherein the functional group of the first precursor has click reactivity with the functional group of the second precursor.

20

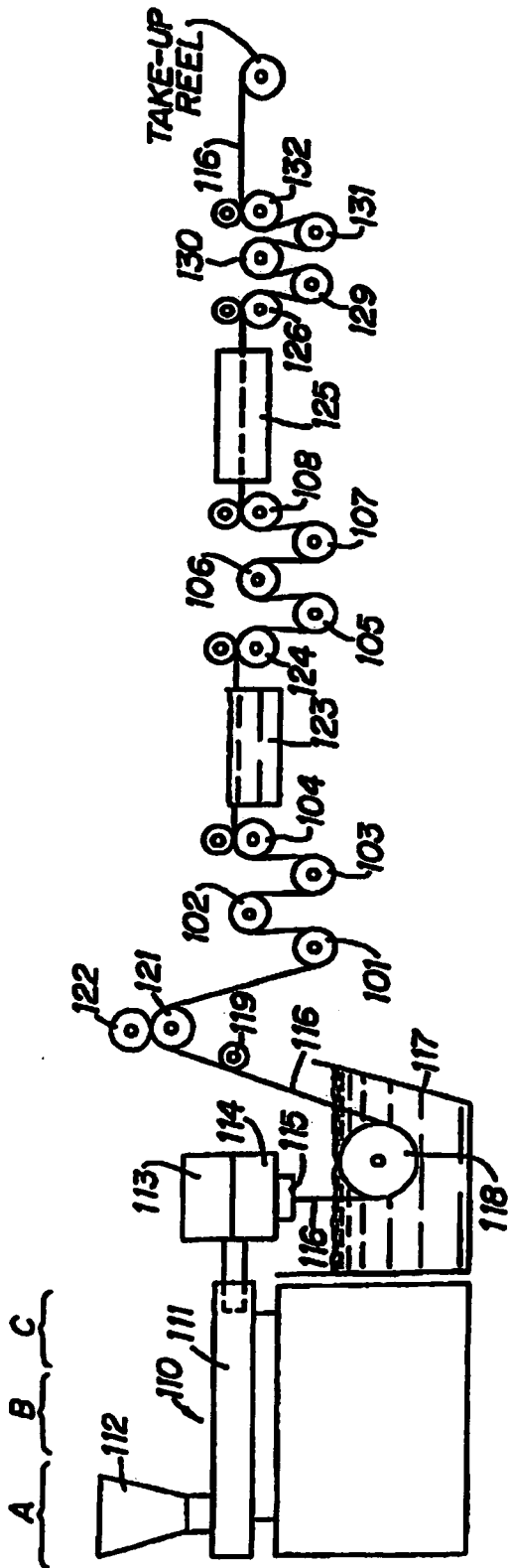

FIGURE 1

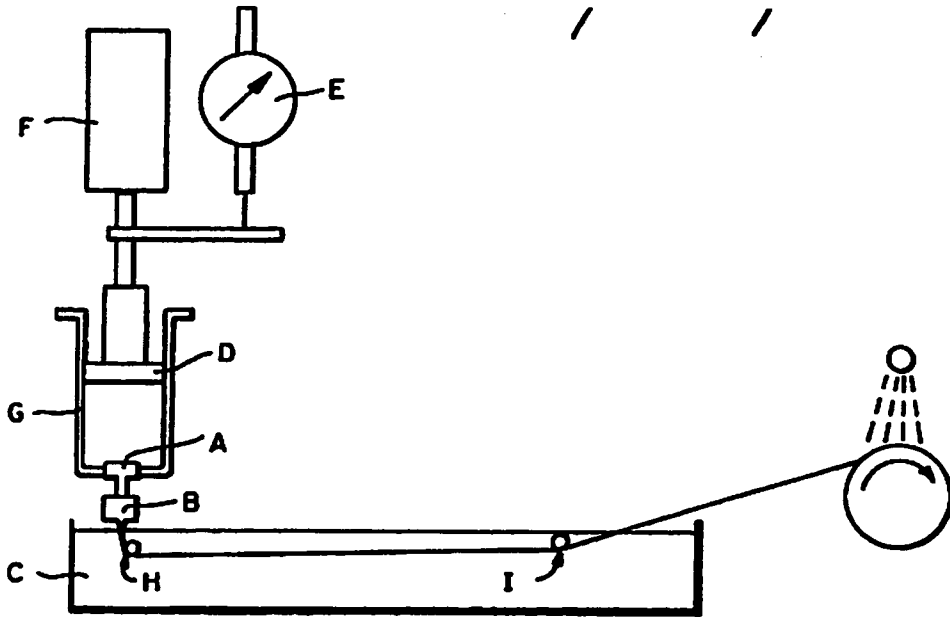

Fig. 2

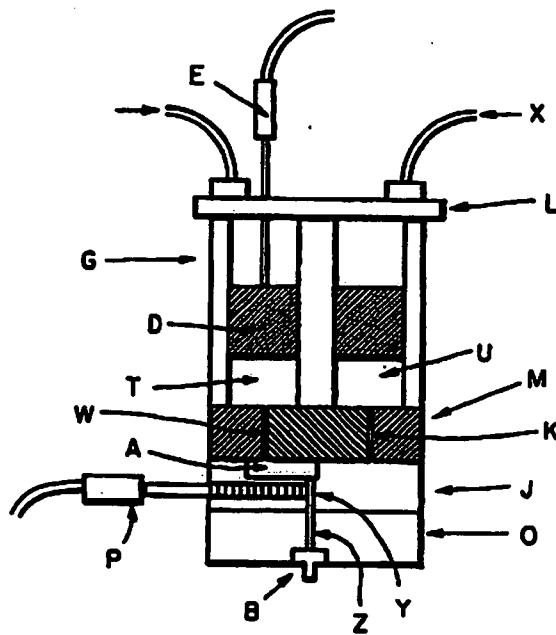

Fig. 3

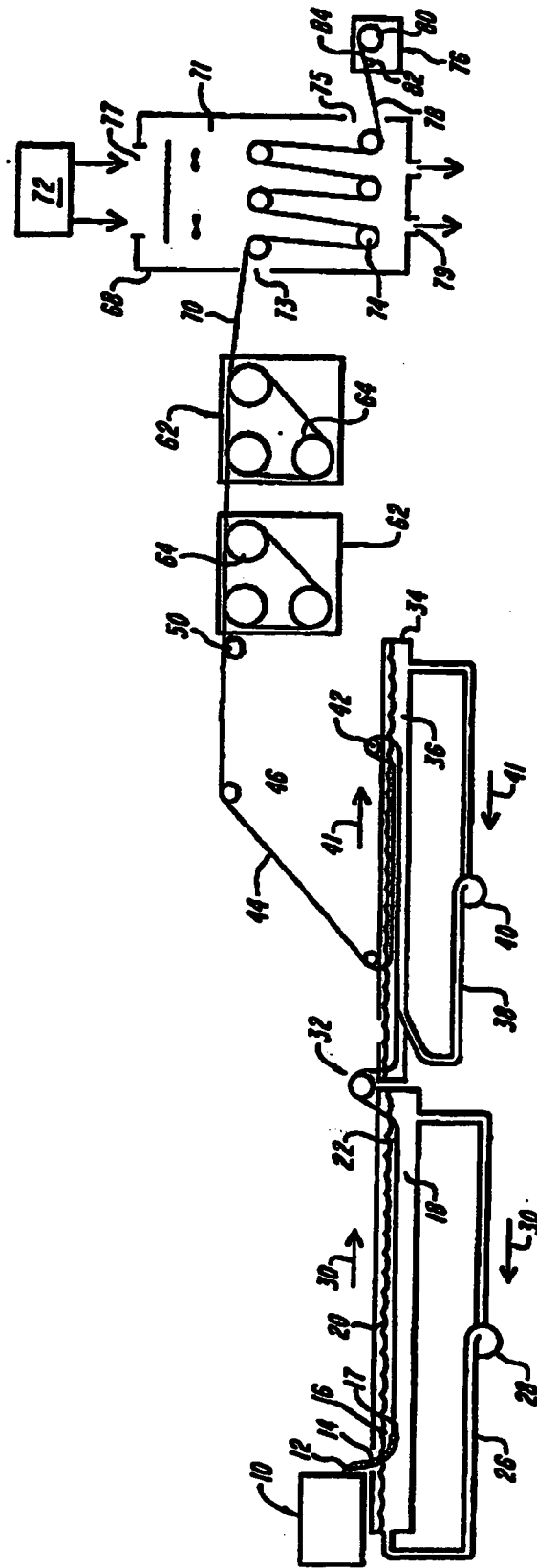

FIG. 4

INTERNATIONAL SEARCH REPORT

International application No
PCT/IB2010/000600

A. CLASSIFICATION OF SUBJECT MATTER

INV. D01F6/00 D01F6/88 D01F6/44
ADD. A61L17/10 D01F4/00 D01F2/00 D01F9/00

According to International Patent Classification (IPC) or to both national classification and IPC

B. FIELDS SEARCHED

Minimum documentation searched (classification system followed by classification symbols)
D01F A61L

Documentation searched other than minimum documentation to the extent that such documents are included in the fields searched

Electronic data base consulted during the international search (name of data base and, where practical, search terms used)

EPO-Internal, WPI Data, COMPENDEX

C. DOCUMENTS CONSIDERED TO BE RELEVANT

Category*	Citation of document, with indication, where appropriate, of the relevant passages	Relevant to claim No.
X	<p>DATABASE WPI Week 199144 Thomson Scientific, London, GB; AN 1991-320678 XP002590920 & JP 3 213511 A (TORAY IND INC) 18 September 1991 (1991-09-18) * abstract</p>	<p>1-3,5, 10-13, 15,20</p>
X	<p>JP 3 294524 A (KANEBO LTD) 25 December 1991 (1991-12-25) * abstract; compounds I, II</p>	<p>1,10,11, 20</p>
	-/--	

Further documents are listed in the continuation of Box C.

See patent family annex.

* Special categories of cited documents :

- *A* document defining the general state of the art which is not considered to be of particular relevance
- *E* earlier document but published on or after the international filing date
- *L* document which may throw doubts on priority claim(s) or which is cited to establish the publication date of another citation or other special reason (as specified)
- *O* document referring to an oral disclosure, use, exhibition or other means
- *P* document published prior to the international filing date but later than the priority date claimed

- *T* later document published after the international filing date or priority date and not in conflict with the application but cited to understand the principle or theory underlying the invention
- *X* document of particular relevance; the claimed invention cannot be considered novel or cannot be considered to involve an inventive step when the document is taken alone
- *Y* document of particular relevance; the claimed invention cannot be considered to involve an inventive step when the document is combined with one or more other such documents, such combination being obvious to a person skilled in the art.
- *&* document member of the same patent family

Date of the actual completion of the international search

8 July 2010

Date of mailing of the international search report

20/07/2010

Name and mailing address of the ISA/

European Patent Office, P.B. 5818 Patentlaan 2
NL - 2280 HV Rijswijk
Tel. (+31-70) 340-2040,
Fax: (+31-70) 340-3016

Authorized officer

Malik, Jan

INTERNATIONAL SEARCH REPORT

International application No
PCT/IB2010/000600

C(Continuation). DOCUMENTS CONSIDERED TO BE RELEVANT		
Category*	Citation of document, with indication, where appropriate, of the relevant passages	Relevant to claim No.
X	<p>DATABASE WPI Week 200882 Thomson Scientific, London, GB; AN 2008-002390 XP002590921 & CN 101 260 570 A (UNIV DONGHUA) 10 September 2008 (2008-09-10) * abstract</p>	1,10,11, 20
X	<p>OSSIPOV D A ET AL: "Poly(vinyl alcohol)-based hydrogels formed by "click chemistry" MACROMOLECULES 20060307 AMERICAN CHEMICAL SOCIETY US, vol. 39, no. 5, 7 March 2006 (2006-03-07), pages 1709-1718, XP002590922 DOI: DOI:10.1021/MA052545P Hydrogel Formation; page 1718; figure 4 page 1709, column 2 - page 1710, column 1 Conclusion; page 1716</p>	1-20
X	<p>BINDER W H ET AL: "click chemistry in polymer and material science" MACROMOLECULAR: RAPID COMMUNICATIONS, WILEY VCH VERLAG, WEINHEIM, DE LNKD- DOI:10.1002/MARC.200600625, vol. 28, no. 1, 22 January 2007 (2007-01-22), pages 15-54, XP002541431 ISSN: 1022-1336 page 29, columns 1-2 page 28, column 2 table 1 the whole document</p>	1-20
A	<p>RIVA R ET AL: "Contribution of 'click chemistry' to the synthesis of antimicrobial aliphatic copolyester" POLYMER, ELSEVIER SCIENCE PUBLISHERS B.V, GB LNKD- DOI:10.1016/J.POLYMER.2008.03.008, vol. 49, no. 8, 15 April 2008 (2008-04-15) , pages 2023-2028, XP022589793 ISSN: 0032-3861 [retrieved on 2008-03-07] cited in the application the whole document</p>	1-20

-/--

INTERNATIONAL SEARCH REPORT

International application No

PCT/IB2010/000600

C(Continuation). DOCUMENTS CONSIDERED TO BE RELEVANT

Category*	Citation of document, with indication, where appropriate, of the relevant passages	Relevant to claim No.
A	SHI ET AL: "The immobilization of proteins on biodegradable polymer fibers via click chemistry" BIOMATERIALS, ELSEVIER SCIENCE PUBLISHERS BV., BARKING, GB LNKD- DOI:10.1016/J.BIOMATERIALS.2007.11.008, vol. 29, no. 8, 26 November 2007 (2007-11-26), pages 1118-1126, XP022398657 ISSN: 0142-9612 cited in the application the whole document -----	1-20

INTERNATIONAL SEARCH REPORT

Information on patent family members

International application No

PCT/IB2010/000600

Patent document cited in search report		Publication date		Patent family member(s)	Publication date
JP 3213511	A	18-09-1991	JP	2830275 B2	02-12-1998
JP 3294524	A	25-12-1991	JP	2902719 B2	07-06-1999
CN 101260570	A	10-09-2008	NONE		