

J. A. SWENSON.
 CARPENTER'S TOOL.
 APPLICATION FILED OCT. 1, 1909.

978,509.

Patented Dec. 13, 1910.

2 SHEETS-SHEET 1.

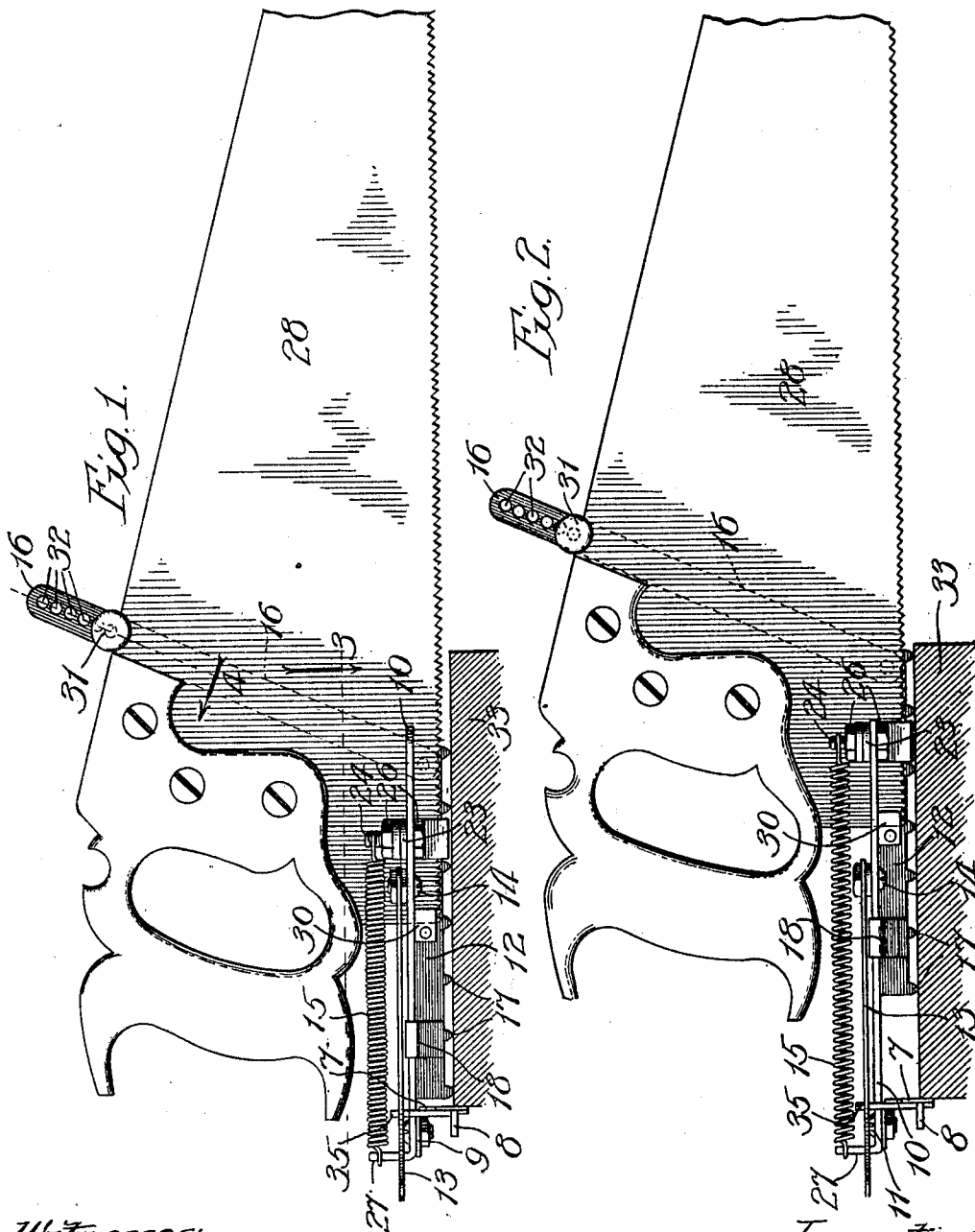

Witnesses:
 John Anders
 Chas. A. Bull.

Inventor:
 Jonas A. Swenson.
 By *Bygren Smith, Lee, Christen & Wiley*
 Attys.

978,509.

Patented Dec. 13, 1910.

2 SHEETS-SHEET 2.

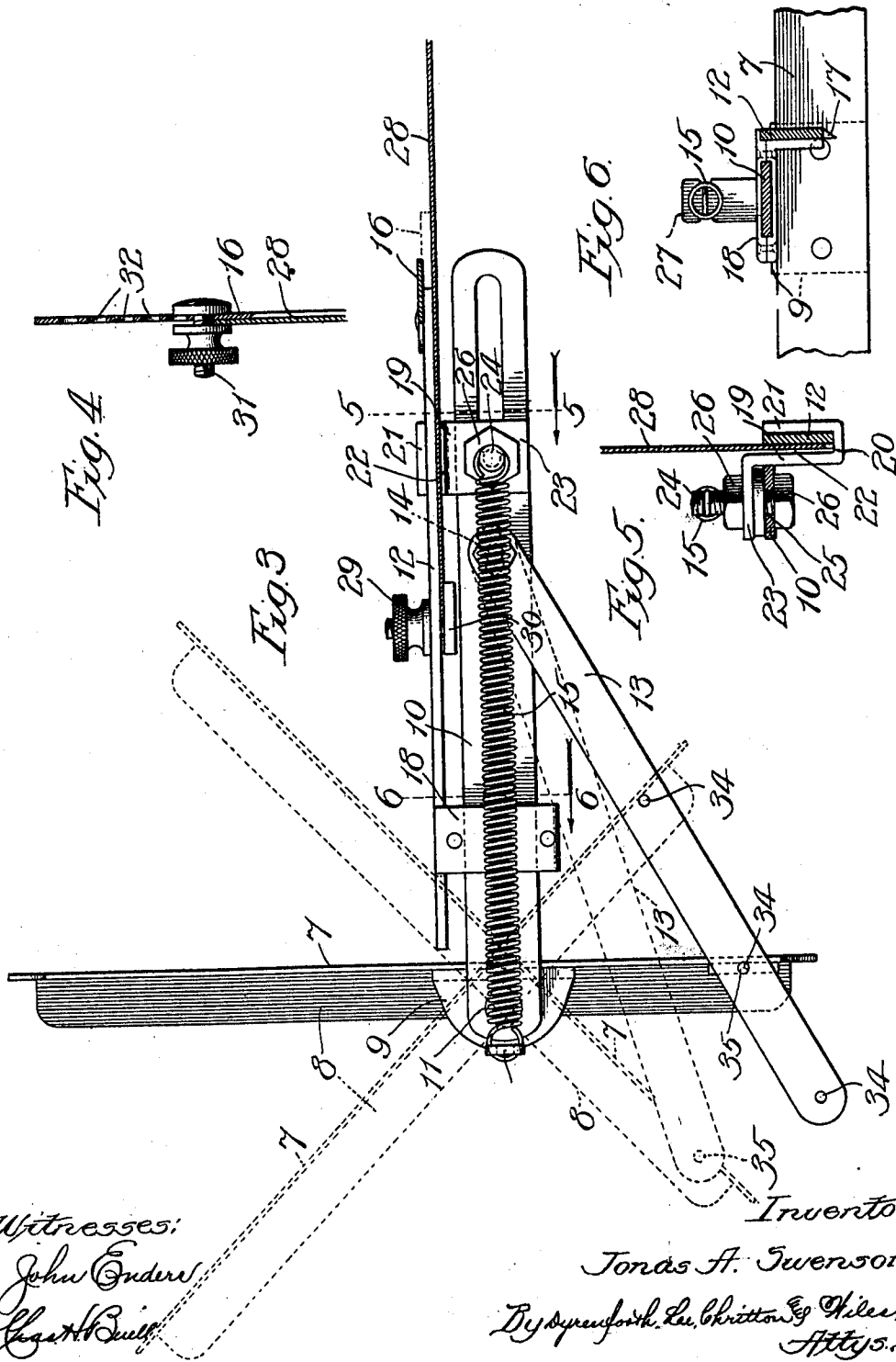

Witnesses:
 John Anders
 Charles Bull

Inventor:
 Jonas A. Swenson
 By Springfield, Lu. Britton & Miles,
 Attys.

UNITED STATES PATENT OFFICE.

JONAS A. SWENSON, OF ST. CHARLES, SOUTH DAKOTA.

CARPENTER'S TOOL.

978,509.

Specification of Letters Patent.

Patented Dec. 13, 1910.

Application filed October 1, 1909. Serial No. 520,551.

To all whom it may concern:

Be it known that I, JONAS A. SWENSON, a citizen of the United States, residing at St. Charles, in the county of Gregory and State of South Dakota, have invented a new and useful Improvement in Carpenters' Tools, of which the following is a specification.

My invention relates to a new and useful improvement in carpenters' tools, and more particularly to square and miter-markers for use in marking flooring, drop-siding, stud-ding and the like, to serve as a guide to the operator in the sawing operation.

It is a common practice with carpenters to use a square or miter-marker disconnected with the saw, which is applied to the board or boards to be sawed and a line drawn across the latter, as with a pencil, each time a cut is to be made. This practice is objectionable as it necessitates the use of two separate tools and a separate marking instrument, such as a pencil, and, furthermore, requires the operator to pick up the marker and pencil every time it is desired to make a mark.

My object is to overcome the objections above referred to, and to provide a simple construction of marker device which may be carried by the saw and used alternately with the latter for making the desired mark, thus avoiding the picking up of the marker and pencil every time a mark is to be made.

A further object is to render the marker adjustable to permit boards to be cut at either a right or an oblique angle.

My invention is illustrated in the accompanying drawings, in which—

Figure 1 is a view in side elevation of a portion of a hand-saw equipped with my improved marker, the latter being shown as applied to a board to be marked and in position thereon preparatory to making the mark. Fig. 2 is a similar view showing the marker and saw in the position they assume after the device has been operated to make the mark. Fig. 3 is an enlarged section taken at the line 3 on Fig. 1 and viewed in the direction of the arrow, the marker being shown in full lines in a position for squaring a board and in dotted lines in positions for producing left and right miter-markings. Fig. 4 is a broken section taken at the line 4 on Fig. 1 and viewed in the di-

rection of the arrow; and Figs. 5 and 6, broken sections taken at the lines 5 and 6, respectively, on Fig. 3.

My improved marker in its preferred embodiment comprises, generally stated, a flat-sided member 7 preferably reinforced by a strip 8 and carrying an angular lug 9 to which a forwardly-extending guide-bar 10 is pivoted, as indicated at 11, a marker-bar 12 spaced from the guide-bar 10 and slidable thereon, a brace 13 pivoted to the bar 10, as indicated at 14, and adjustably connected with an end of the member 7 as hereinafter described, a spring 15 tending to draw the bar 12 toward the member 7, and a saw-engaging arm 16 carried by the forward end of the bar 12.

The marker-bar 12, which is provided on its lower edge with teeth 17, or any other suitable marking means, carries at its rear end a strap 18 surrounding the guide-bar 10, and at its forward end a depending hook-shaped lug 19, the bar 12 lying within the upwardly-opening channel 20 thus provided and being secured to the inner face of the outer portion 21 of this lug, as represented in Fig. 5, the width of this channel being greater than the thickness of the bar 12 to present an upwardly-opening groove 22 in which the saw may be seated, as hereinafter described. The lug 19 has a straight portion 23 which overlies the guide-bar 10 and carries a screw-threaded stud 24 extending at its lower end through a slot 25 in the forward end of the bar 10, nuts 26 being screwed upon this stud to hold the latter to the lug 19 and slidably confine the stud in the slot 25. By connecting the marker-bar 12 with the guide-bar 10, as described, the former is free to be moved back and forth on the guide-bar and is positively guided thereon. The spring 15, which, by preference, is of the coil type, is connected at its opposite ends with the stud 24 and with a lug 27 carried on the rear end of the guide-bar 10, whereby the marker-bar 12 is normally drawn under spring tension toward the member 7.

The marker device is applied to a hand-saw, such as, for instance, that represented at 28, by first seating the cutting edge of the saw in the groove 22 and thereupon fastening it in place by a thumb-clamp 29 on the

bar 12, which engages with the back edge of the saw and holds the latter between a plate 30 on the clamp and the inner face of the bar 12. The arm 16 is then swung upon its pivot to the position illustrated in Figs. 1 and 2 to cause it to extend above the upper edge of the saw, and is there clamped in place by a thumb-clamp 31 which extends through any one of the holes 32 in the arm 16, the provision of a plurality of holes permitting of the application of the marker to saws of different sizes.

The marking of the board, such as that represented at 33, is effected by applying the marker, while in position on the saw as described, to the board in a position to cause the member 7 to fit flatwise against the edge of the board and the marker-bar 12, the lower edge of which lies in a plane above the lower edge of the member 7, to rest against the face of the board. With the marker in this position, the operator grasps the handle of the saw and moves it forward from the position represented in Fig. 1 to that represented in Fig. 2, the bar 12 in this movement moving along the bar 10 against the tension of the spring 15 and cutting at its teeth into the board, thus making the guide-mark desired. If necessary, the marker-bar may be moved back and forth a number of times as described to make the mark desired. The mark thus produced serves as a guide for the operator when using the saw to cut the board. It will be manifest that the parts of the marker device return to the normal position represented in Fig. 1 under the action of the spring 15. The angle at which the mark so made extends with relation to the edge of the board corresponds to the angle at which the member 7 extends with relation to the marker-bar 12. Thus, if it is desired that the mark be at a right angle to the edge of the board, the member 7 should be adjusted to extend at a right angle to the bar 12, and if a left or right miter-marking is desired, the member 7 should be adjusted to extend at a corresponding oblique angle to the bar, as represented by dotted lines in Fig. 3, this change of angle being permissible by reason of the pivotal connection of the member 7 with the guide-bar 10. To permit this change of adjustment to be quickly effected and to maintain the parts of the marker device in adjusted position, I provide the brace 13 in its free end portion with a plurality of openings 34 which cooperate with an upwardly-extending stud 35 carried on one end of the member 7 and adapted to be inserted into any one of the openings 34 for holding the member 7 and bar 10 in rigid adjusted position. In the construction shown three of these openings are provided, the central one permitting the member 7

and bar 10 to be held at right angles to each other, and the end ones permitting these parts to be adjusted at angles of 45° and 135° respectively for producing left and right miters.

It will be manifest from the foregoing description that by employing my invention the act of making the mark desired may be quickly effected, and that the annoyance and loss of time resulting from the prior practice hereinbefore referred to is obviated.

What I claim as new and desire to secure by Letters Patent, is—

1. A marking device comprising, in combination, a member adapted to be applied to an edge of the object to be marked, means operatively connected with said member and movable with relation thereto for marking the object, means for securing the device at its marker means to a saw, and an upwardly extending arm secured to said last referred-to means and adapted to engage with the saw at its upper edge, for the purpose set forth.

2. A marking device comprising, in combination, a member adapted to be applied to an edge of the object to be marked, a guide-bar secured to said member containing a slot, a marker-bar provided with guides engaging with said guide-bar, one of said guides being connected with said bar at its slotted portion, a coiled spring operatively connected with said marker-bar and member, and means for securing a saw to the device to move with said marker-bar, for the purpose set forth.

3. A marking device comprising, in combination, a member adapted to be applied to an edge of the object to be marked, a guide-bar carried by said member, a marker-bar having guides slidably engaging with said guide-bar, one of said guides being in the form of an upwardly-opening hook engaging at one end with said guide-bar and being connected at its hook end with said marker-bar and affording an upwardly-opening groove adapted to receive the edge of a saw, and means for securing the saw in position on the device.

4. A marking device comprising, in combination, a member adapted to be applied to an edge of the object to be marked, a guide-bar pivotally connected with said member and containing a slot in its outer end portion, a marker-bar carrying guides engaging with said guide-bar, the forward one of said guides being of hook shape and provided with a stud which engages with the slotted portion of said guide-bar, the marker-bar extending into the channel afforded by said hook-shaped guide and secured therein, a spring connected with said hook-shaped guide and with said member, a brace pivotally connected with said guide-bar and

adjustably connected with said member, a clamping device carried by said marker-bar in the rear of said hook-shaped guide and adapted to clamp the back edge of a saw seated in the groove provided by said hook-shaped guide, and an arm pivotally connected with said marker-bar and carrying a clamping device adapted to clamp the saw at its upper edge to said arm, for the purpose set forth.

JONAS A. SWENSON.

In presence of—

GILBERT O. BLEGEN,

J. F. SPOTZ.