



US 20100030475A1

(19) **United States**

(12) **Patent Application Publication**  
**Sohl, III et al.**

(10) **Pub. No.: US 2010/0030475 A1**

(43) **Pub. Date: Feb. 4, 2010**

(54) **SMART DATA SUBSURFACE DATA  
REPOSITORY SYSTEM, METHOD AND  
COMPUTER PROGRAM PRODUCT**

(60) Provisional application No. 60/412,575, filed on Sep. 23, 2002.

(75) Inventors: **John H. Sohl, III**, Potomac, MD (US); **James Edward Tillman**, Ellicott, MD (US)

**Publication Classification**

(51) **Int. Cl.**  
**G06F 19/00** (2006.01)

(52) **U.S. Cl.** ..... **702/2**

Correspondence Address:

**VENABLE LLP**  
**P.O. BOX 34385**  
**WASHINGTON, DC 20043-9998 (US)**

(57) **ABSTRACT**

A system, method and computer program product for source area contamination data acquisition, analysis and processing. The present invention leverages and expands direct sensing technology, knowledge and experience to provide detailed, real-time images of subsurface conditions. The latest technologies in sensors, digital processing, computation and 3D visualization are used to enable clients to work with a single contractor who can perform data acquisition, processing and analysis necessary to produce quantifiable, user-friendly 3D maps on a daily basis which can be delivered via the Internet and/or to mobile devices. This allows the owner and site project manager to make timely decisions as they guide investigation, remediation and monitoring efforts.

(73) Assignee: **Columbia Technologies , LLC**, Halethorpe, MD (US)

(21) Appl. No.: **12/537,117**

(22) Filed: **Aug. 6, 2009**

**Related U.S. Application Data**

(63) Continuation of application No. 10/666,557, filed on Sep. 22, 2003, now abandoned.

300

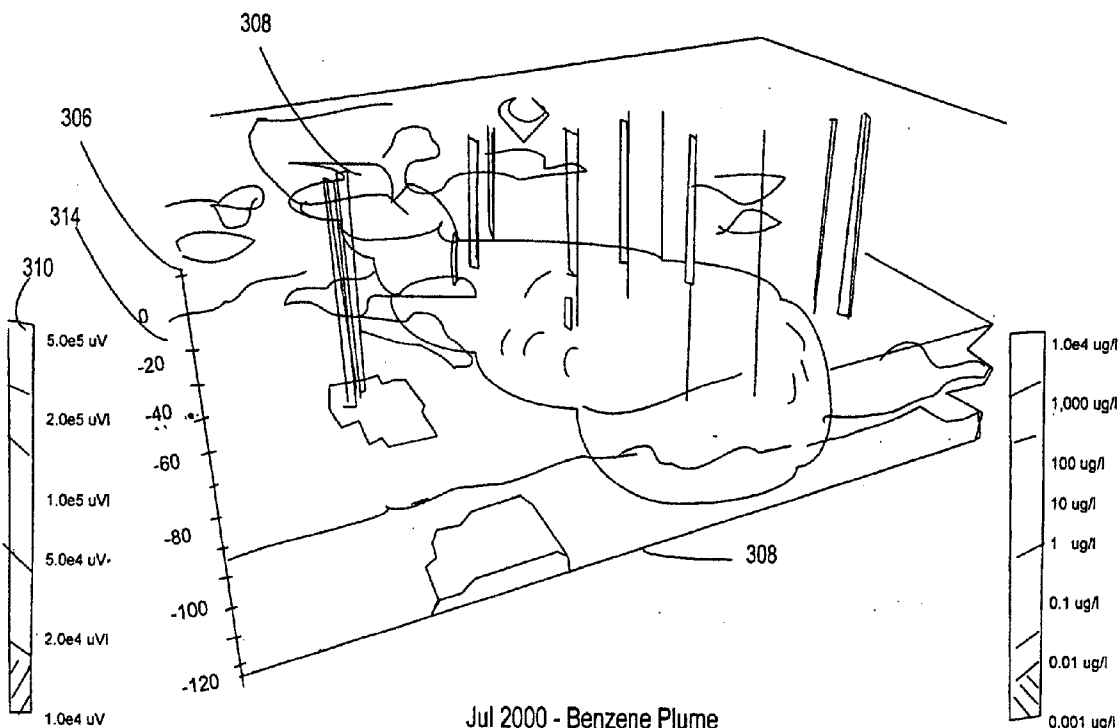

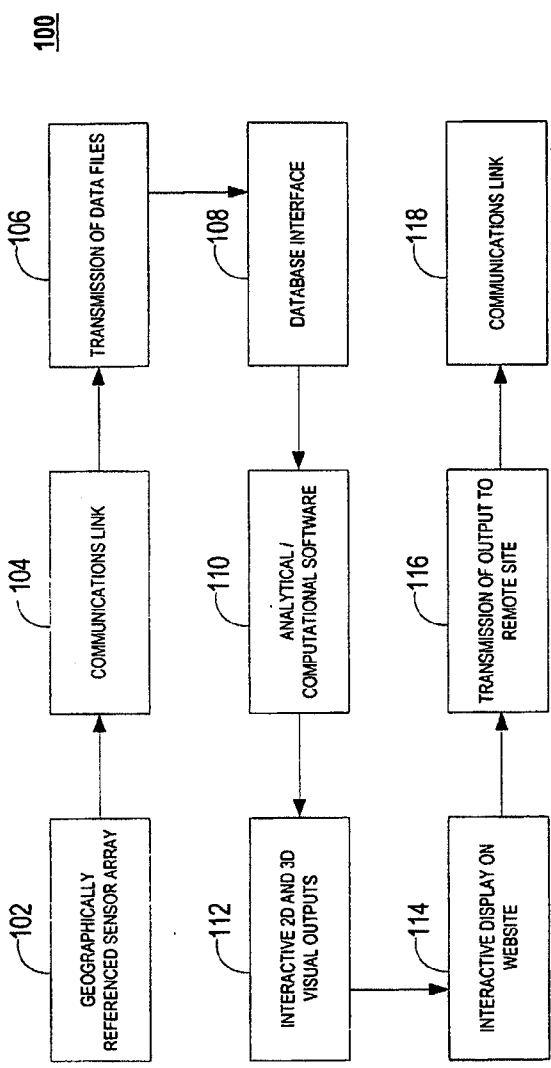

FIG. 1

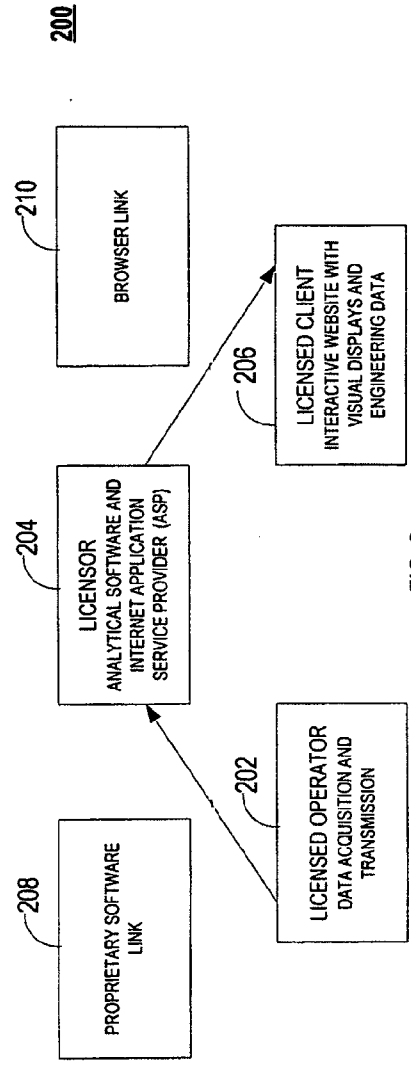
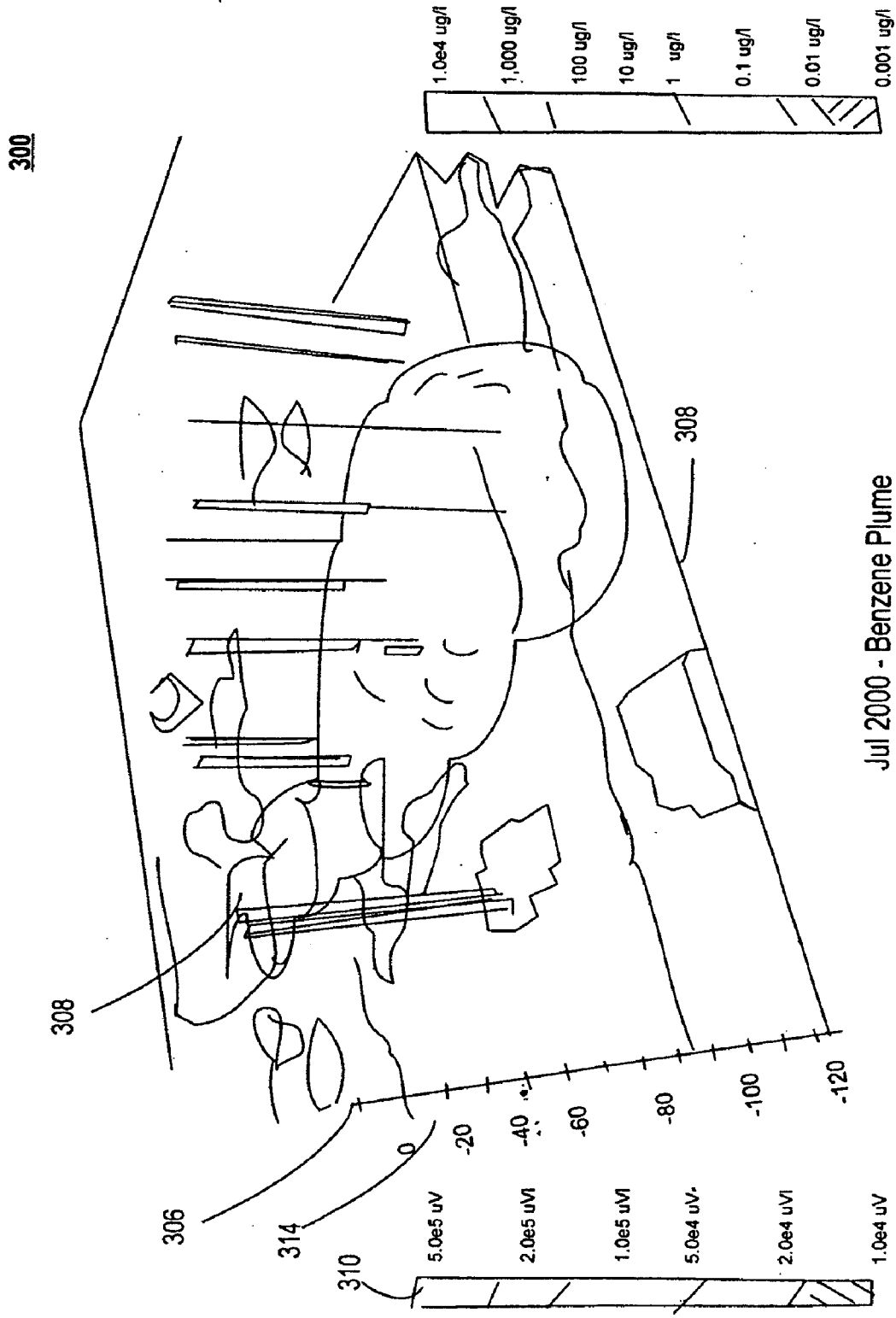
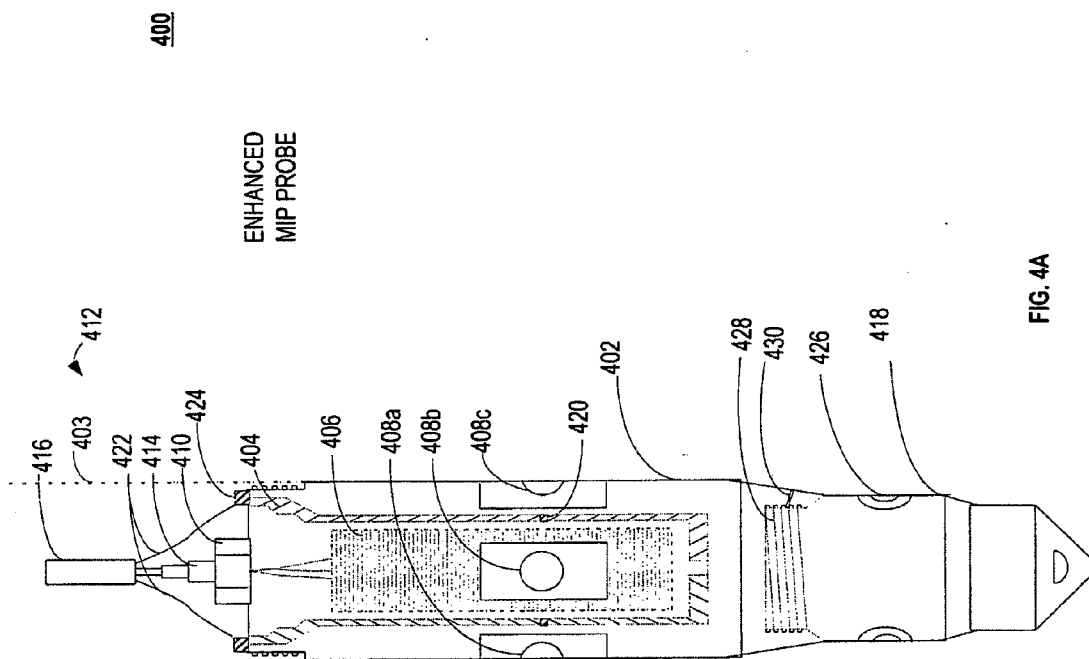

FIG. 2



Jul 2000 - Benzene Plume

FIG. 3



440

- NOTES:
1. SEACON LSG-6-BC HP BULKHEAD CONNECTOR
  2. SEACON RMG-6-FS INLINE CONNECTOR (WATERBLOCKED)
  3. WATERBLOCKED BREAKOUT SPLICE (SCRIPPS)
  4. LENGTH OF NYLON TUBE BREAKOUT TO BE 0.5 IN. LONGER THAN THE LENGTH OF THE RMG BREAKOUT. USE THE FACE OF RMG CONNECTOR AND THE FURTHEST EXTENT OF THE SHORTEST NYLON TUBE AS DATUM POINTS
  5. LENGTH OF BREAKOUT SPLICE TO BE AS SHORT AS POSSIBLE
  6. CUSTOM HEATER ELEMENT WITH THROUGH CONDUCTOR AND GROUND CONDUCTOR
  7. HEATER CARTRIDGE INSERT
  8. MODIFIED PROBE
  9. O-RING SEATED GAS PASSAGES
  10. 4 # 10 CAP SCREWS PERPENDICULAR TO PROBE SURFACE EQUALLY SPACED

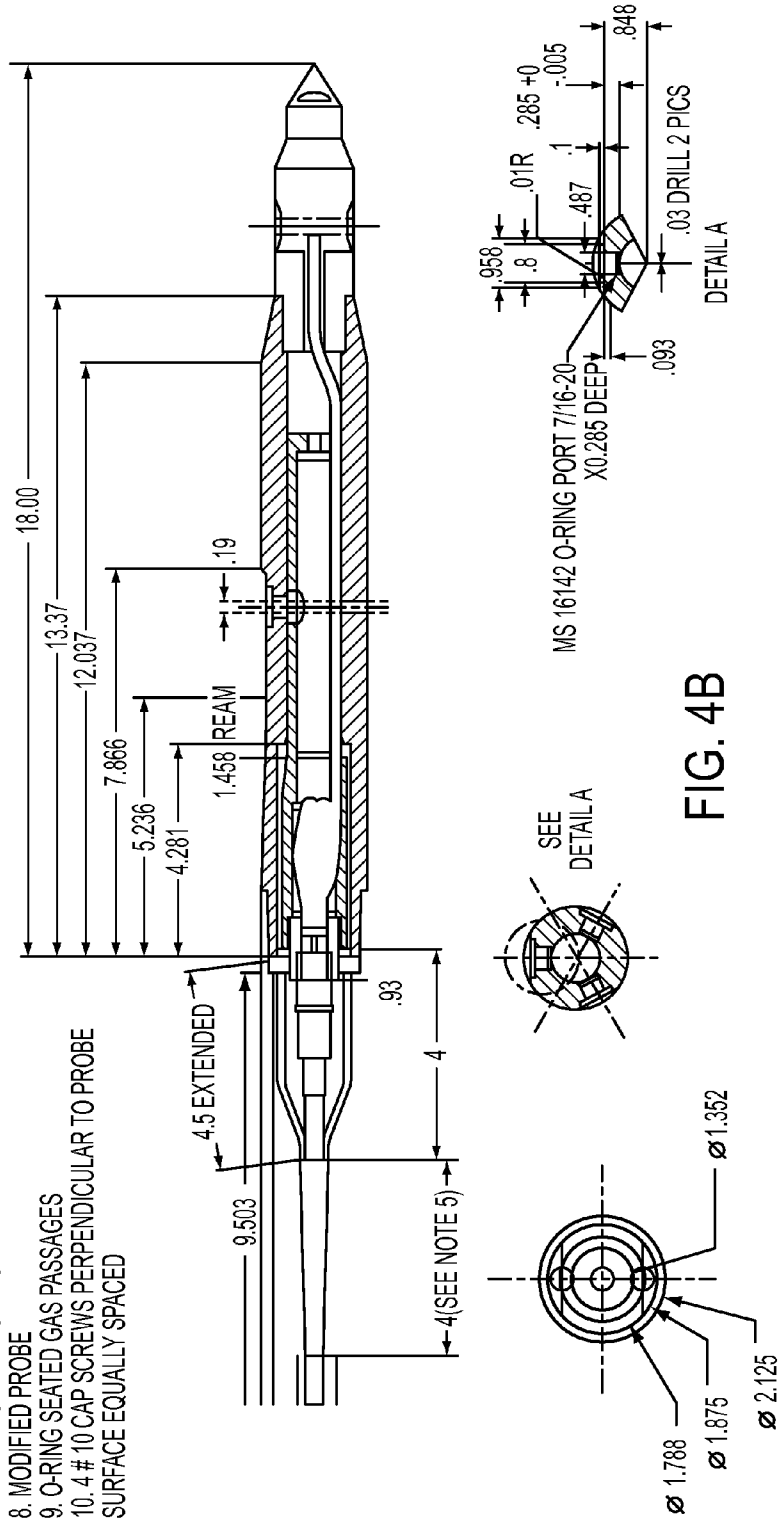

FIG. 4B

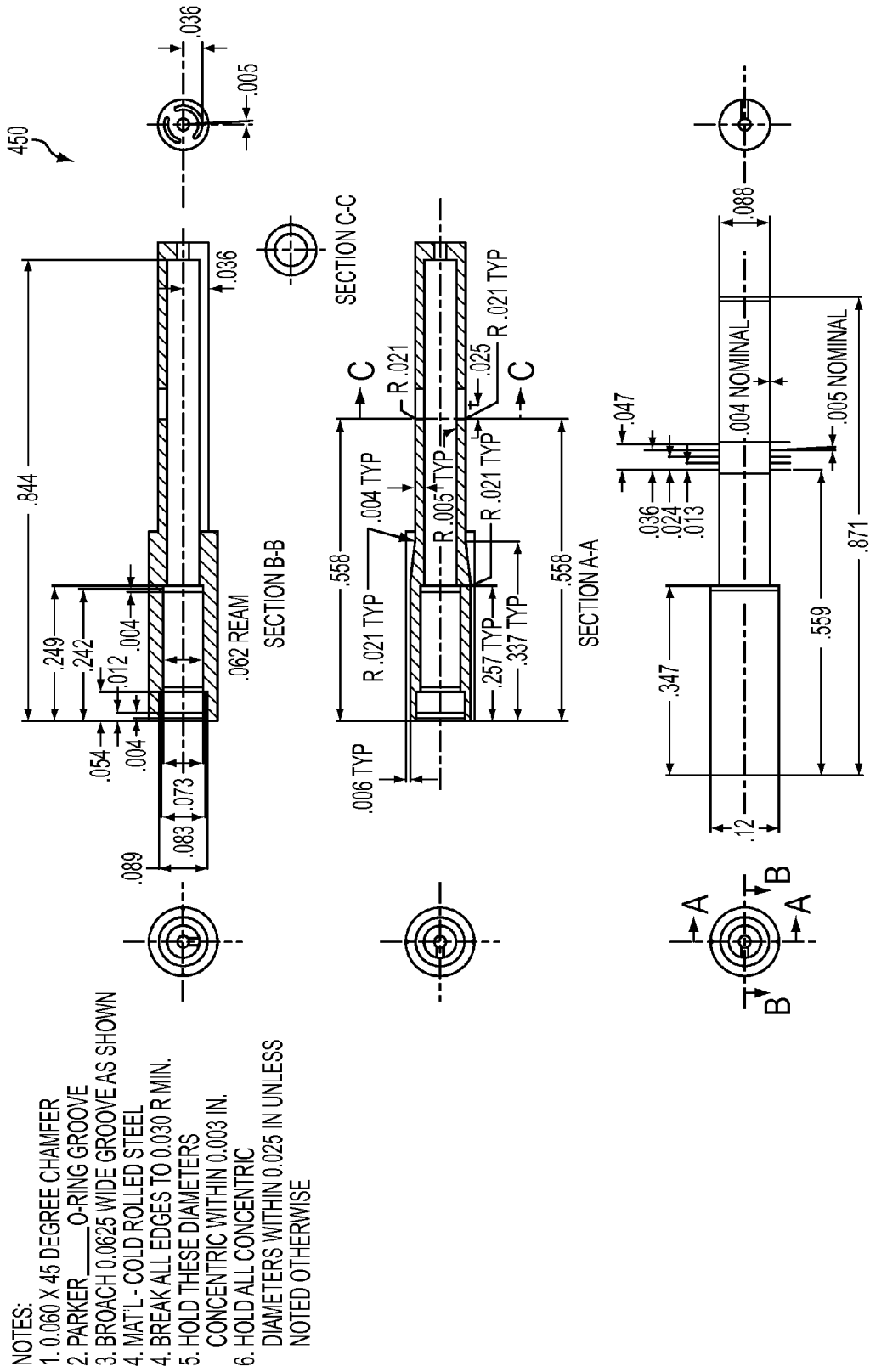

FIG. 4C

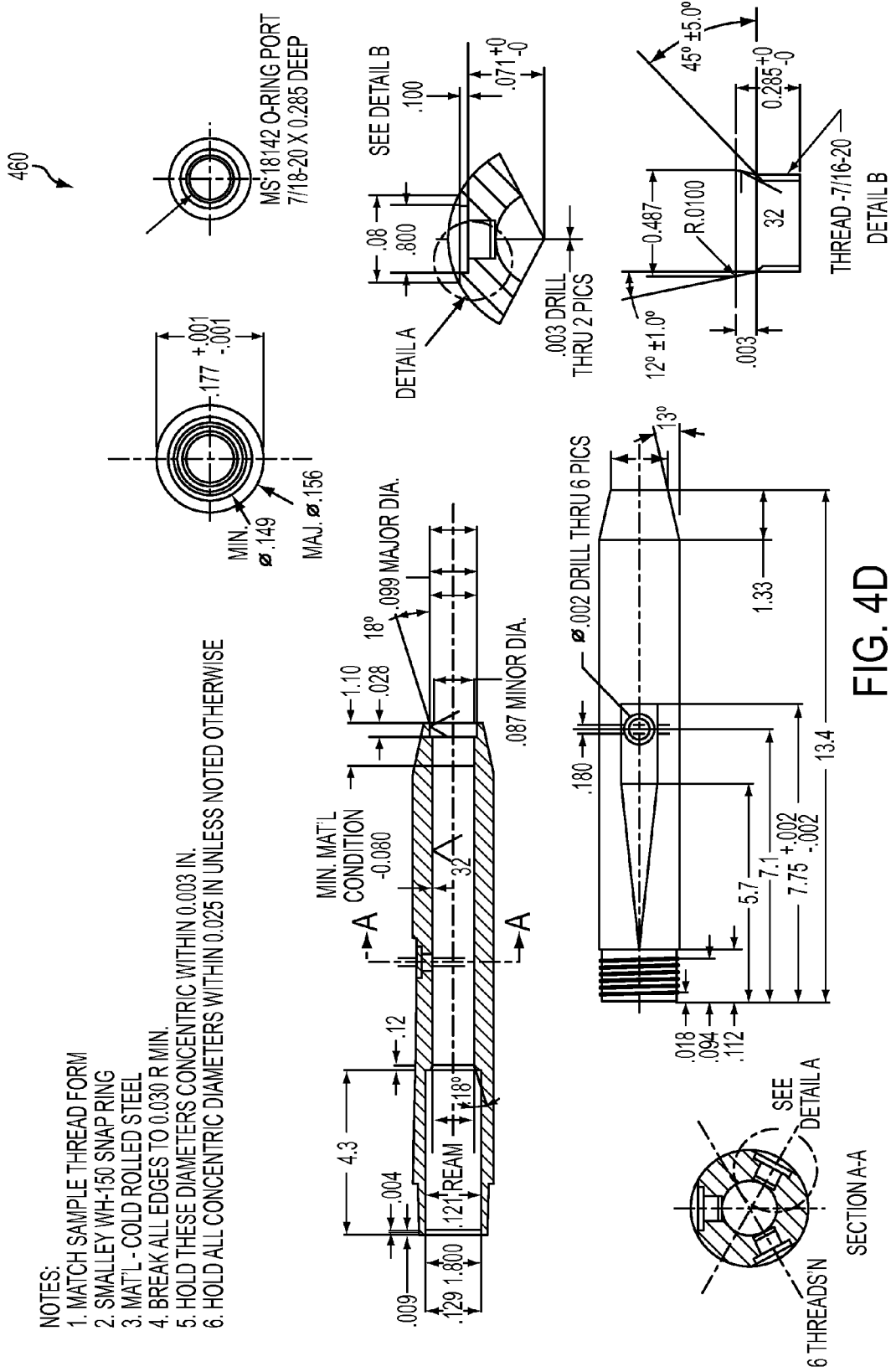

FIG. 4D

NOTES:

1. MATCH SAMPLE THREAD FORM
2. SMALLEY WH-150 SNAP RING
3. MAT'L - COLD ROLLED STEEL
4. BREAK ALL EDGES TO 0.030 R MIN.
5. HOLD THESE DIAMETERS CONCENTRIC WITHIN 0.003 IN.
6. HOLD ALL CONCENTRIC DIAMETERS WITHIN 0.025 IN UNLESS NOTED OTHERWISE

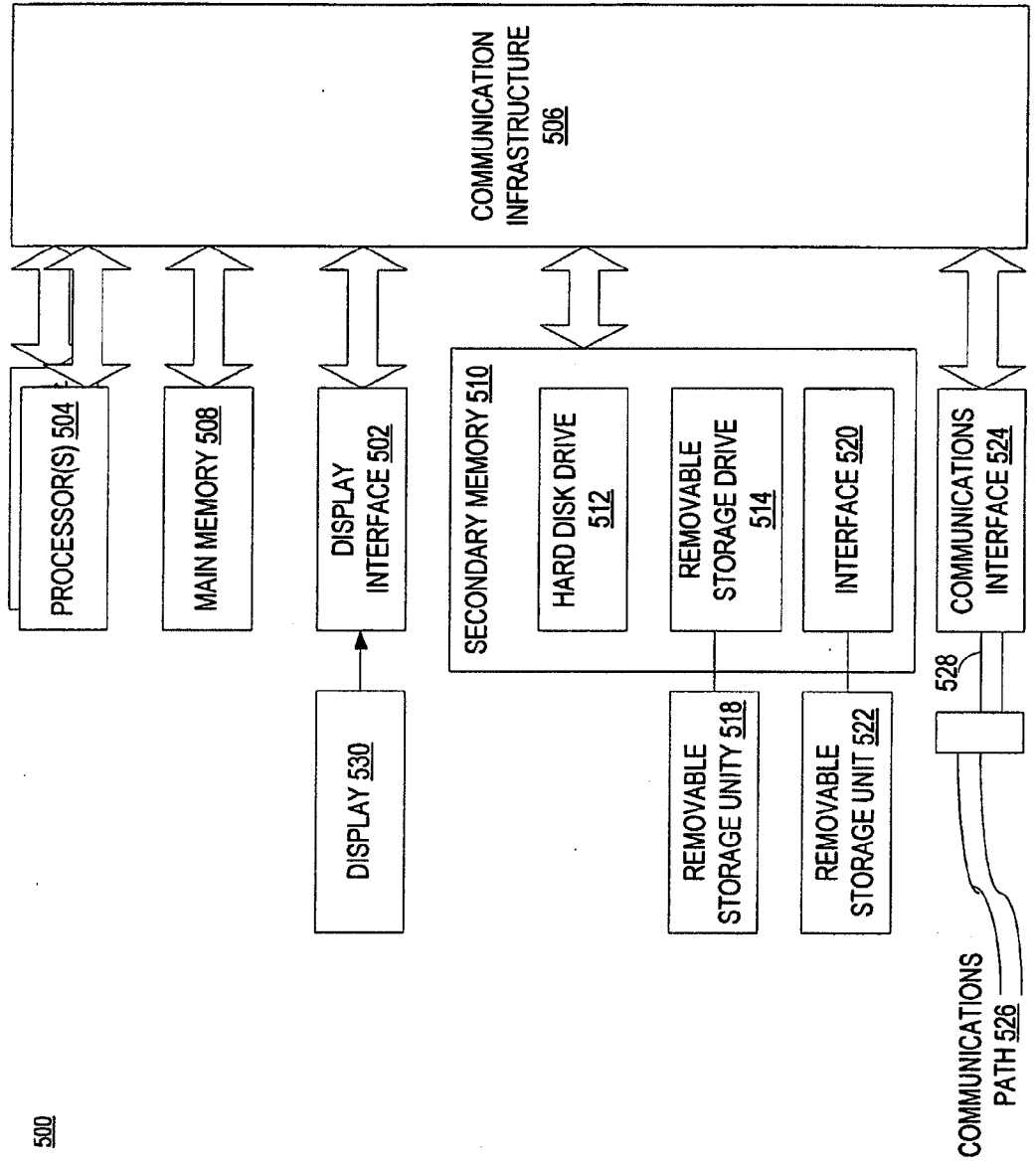

FIG. 5



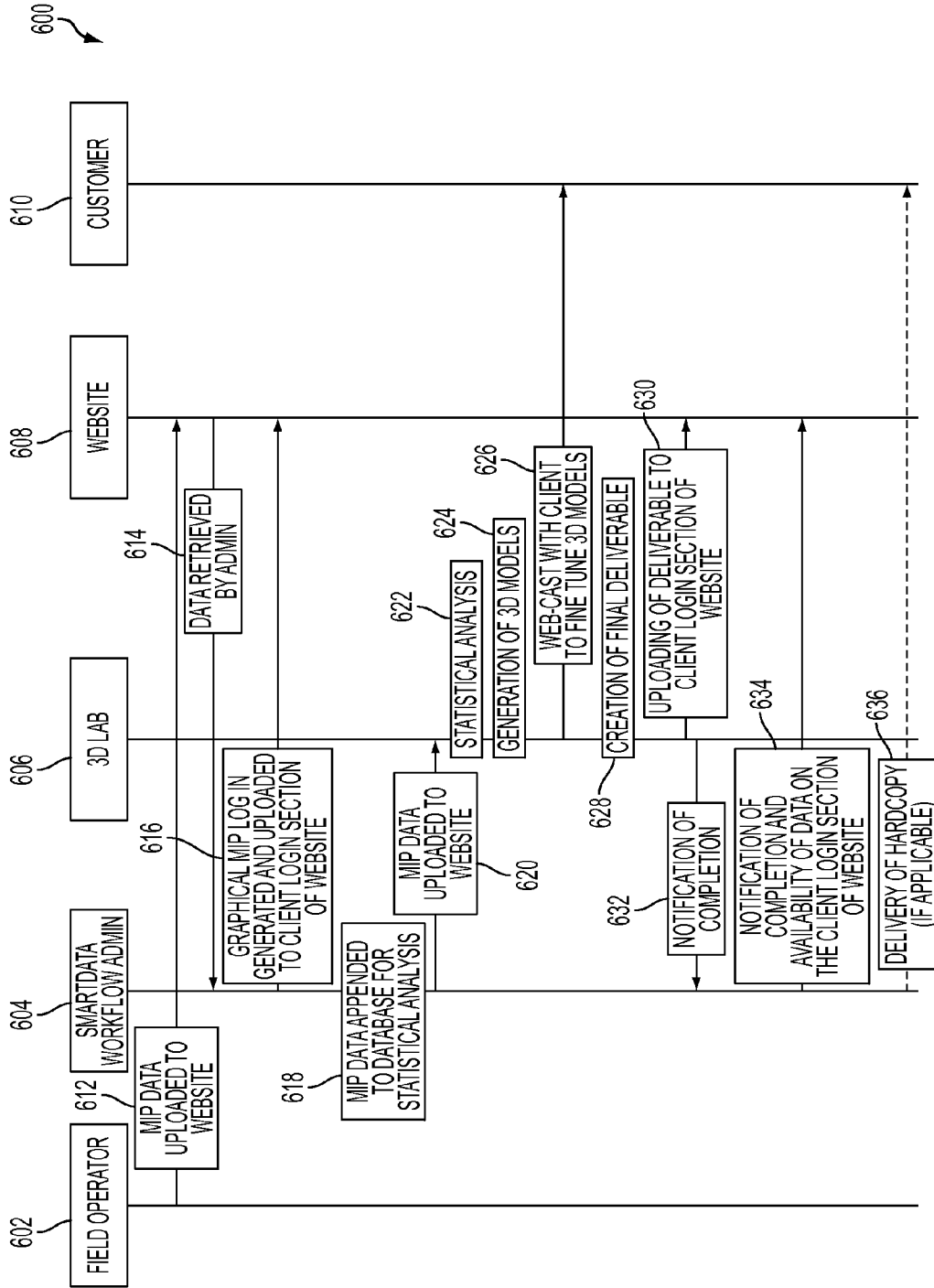

FIG. 6

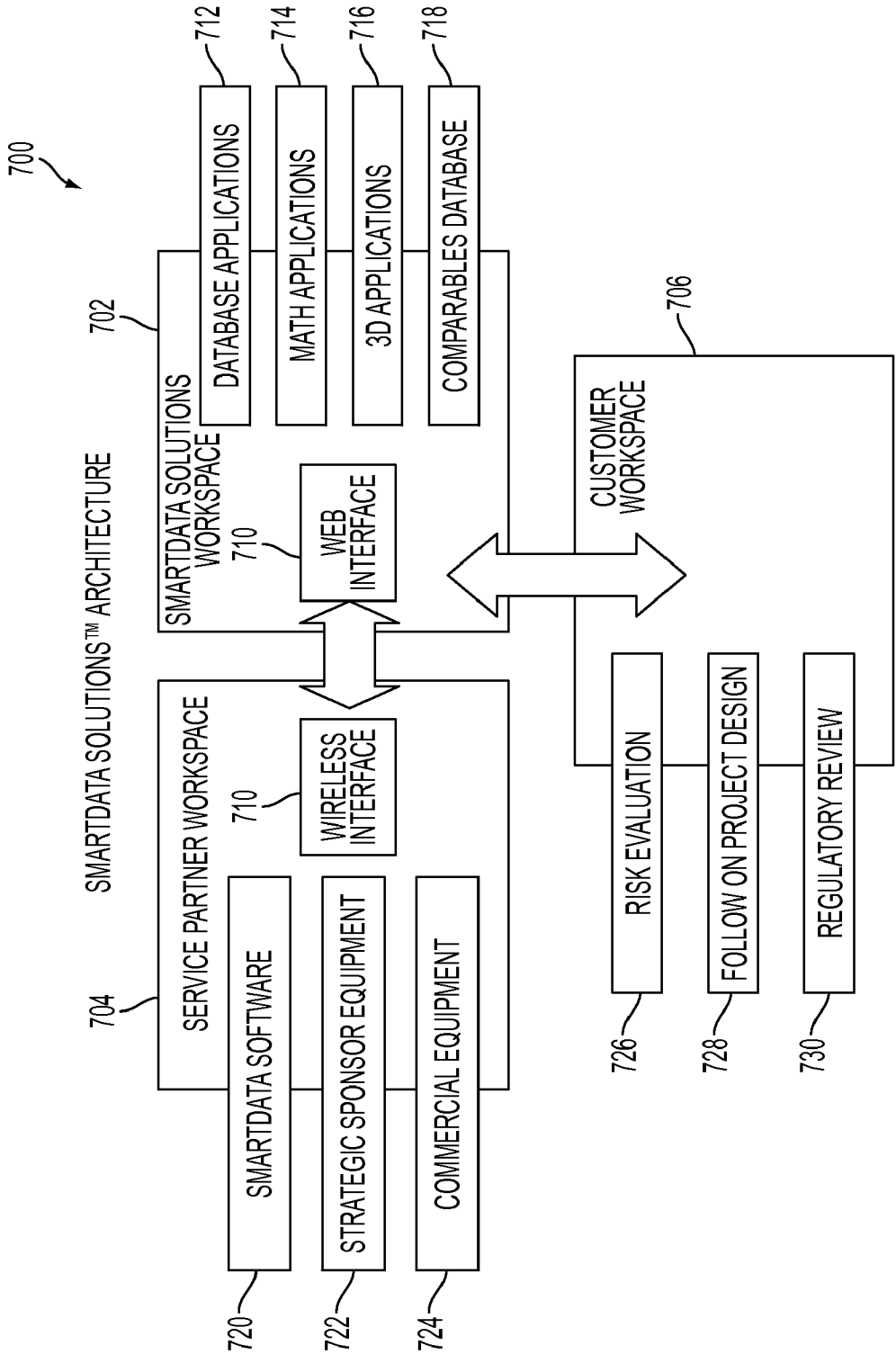

FIG. 7

800

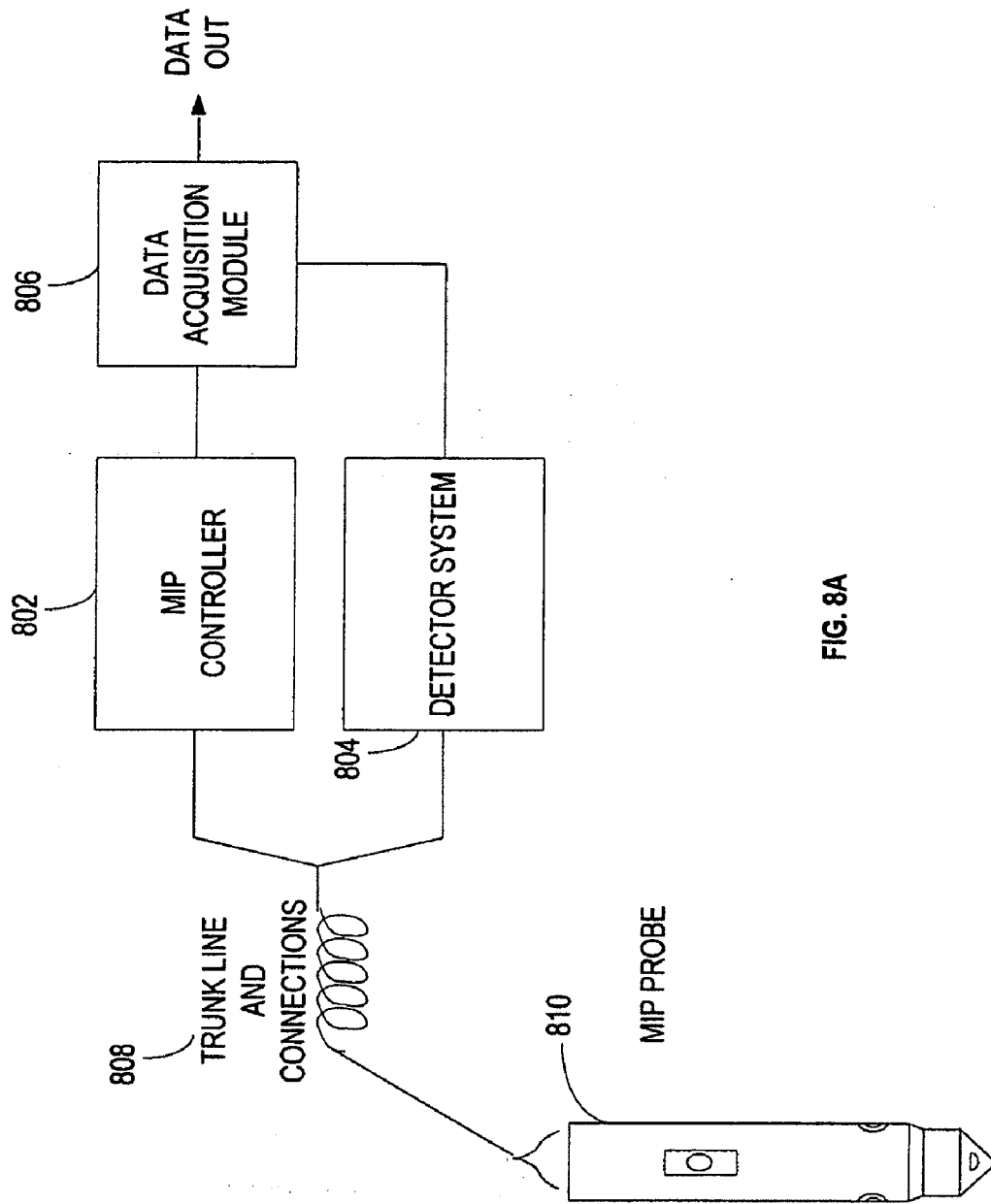

FIG. 8A

810

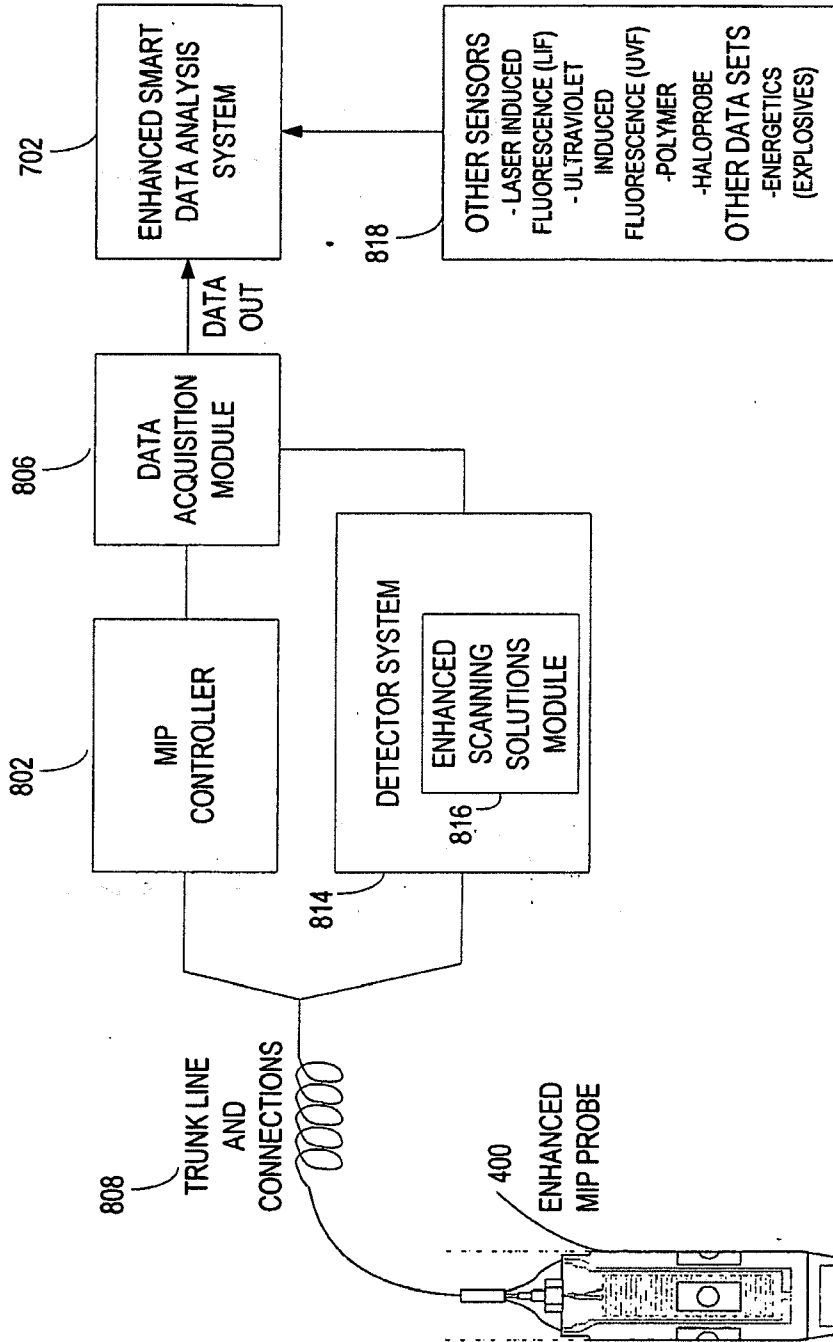

FIG. 8B

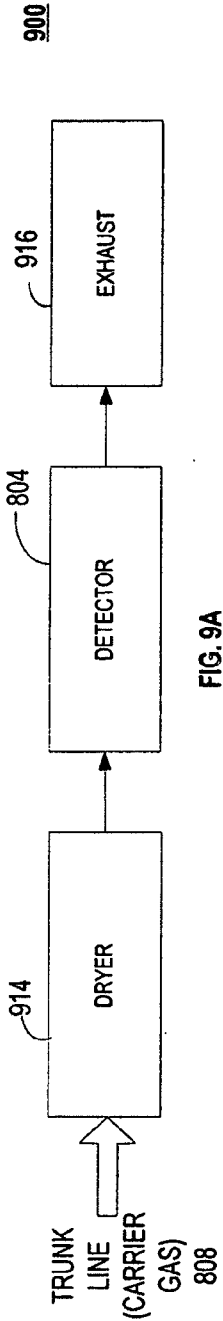

FIG. 9A

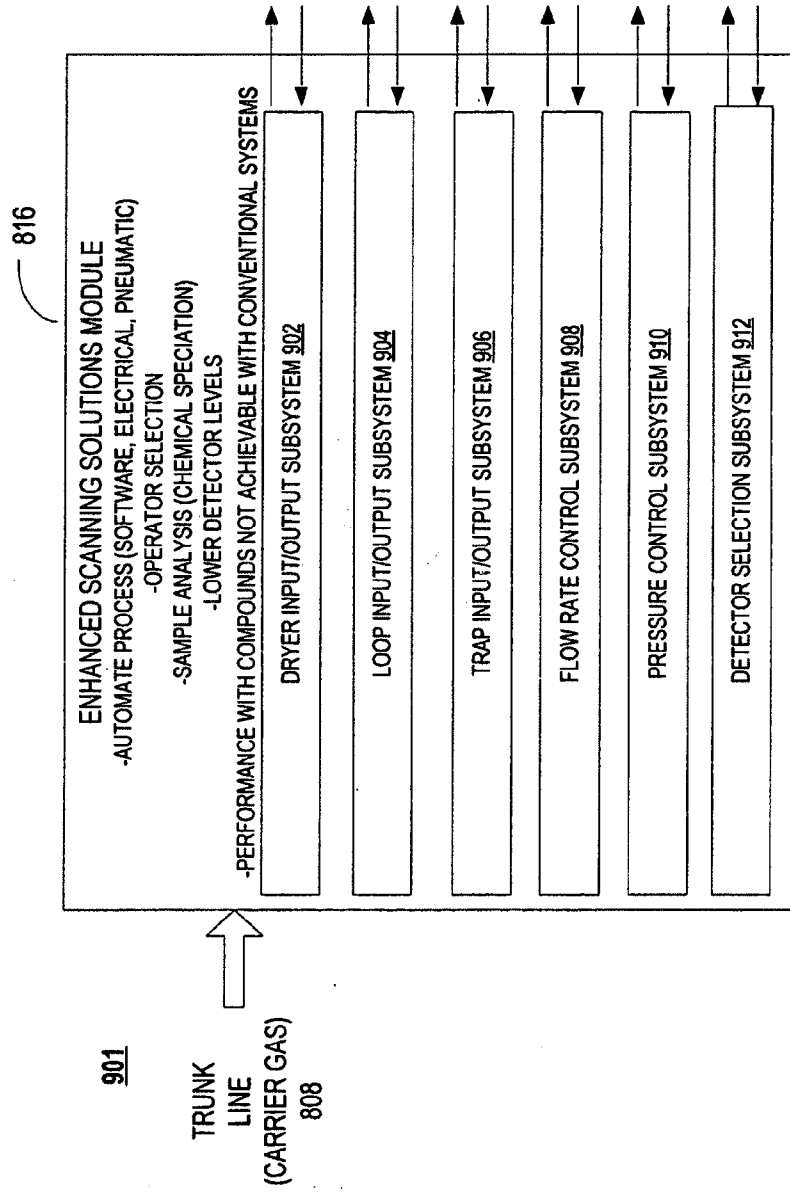

FIG. 9B

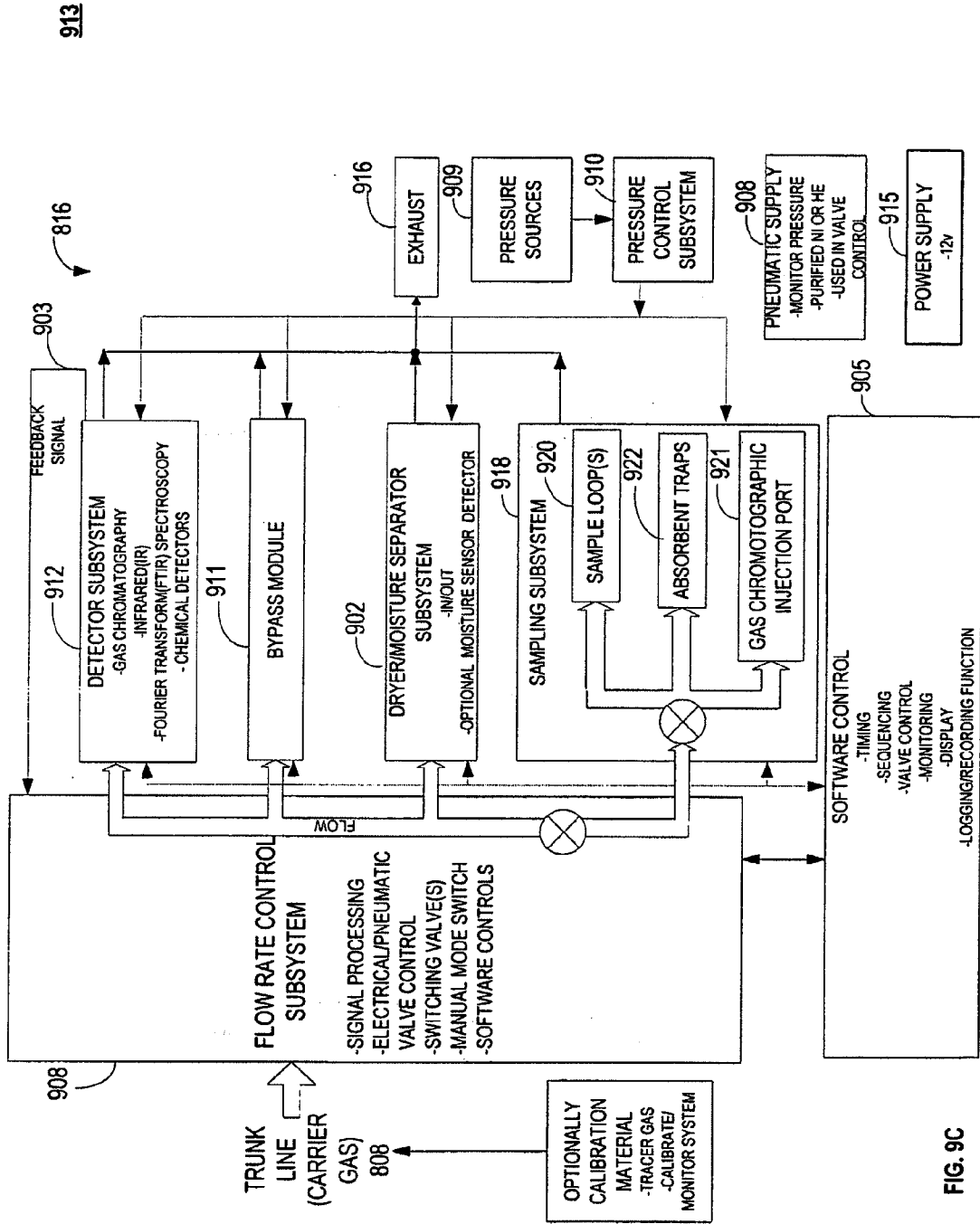

FIG. 9C

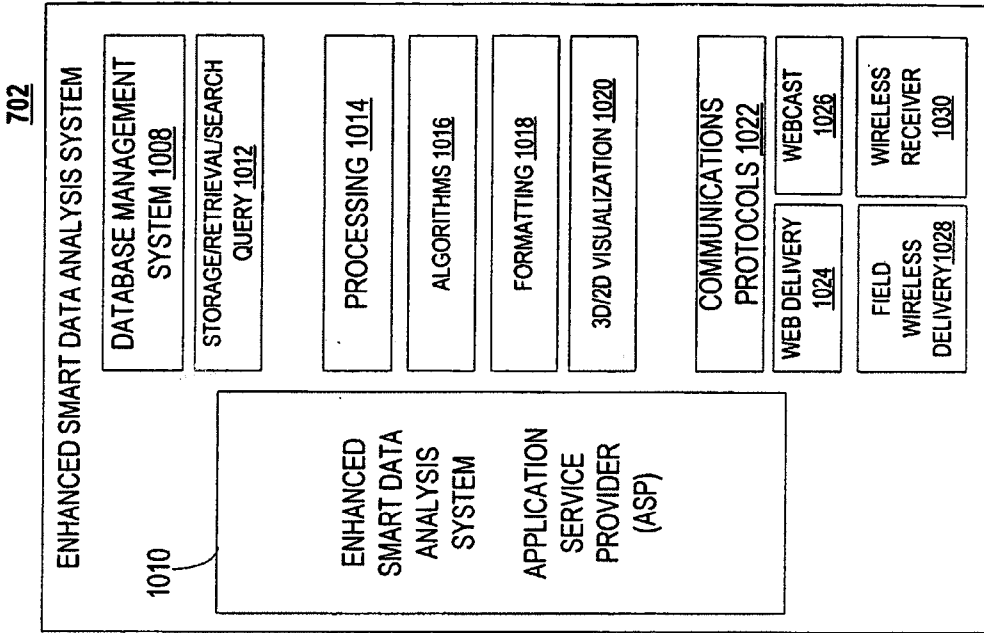

FIG. 10A

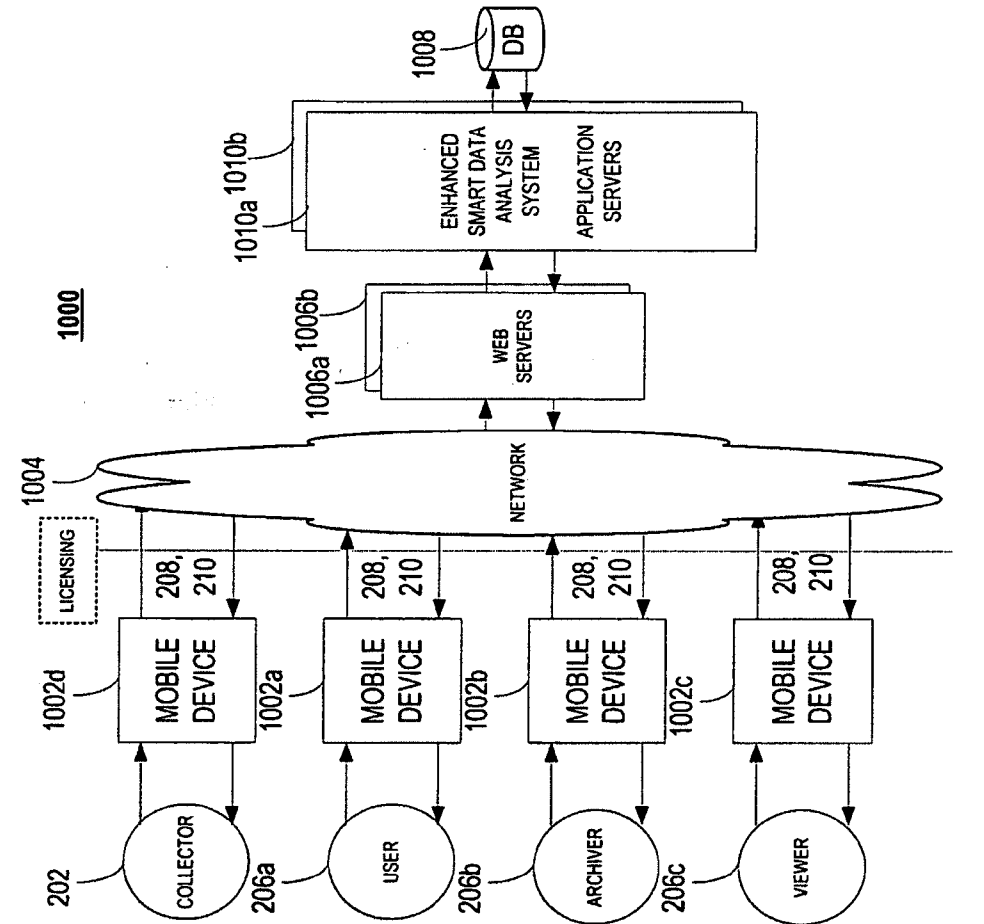

FIG. 10B

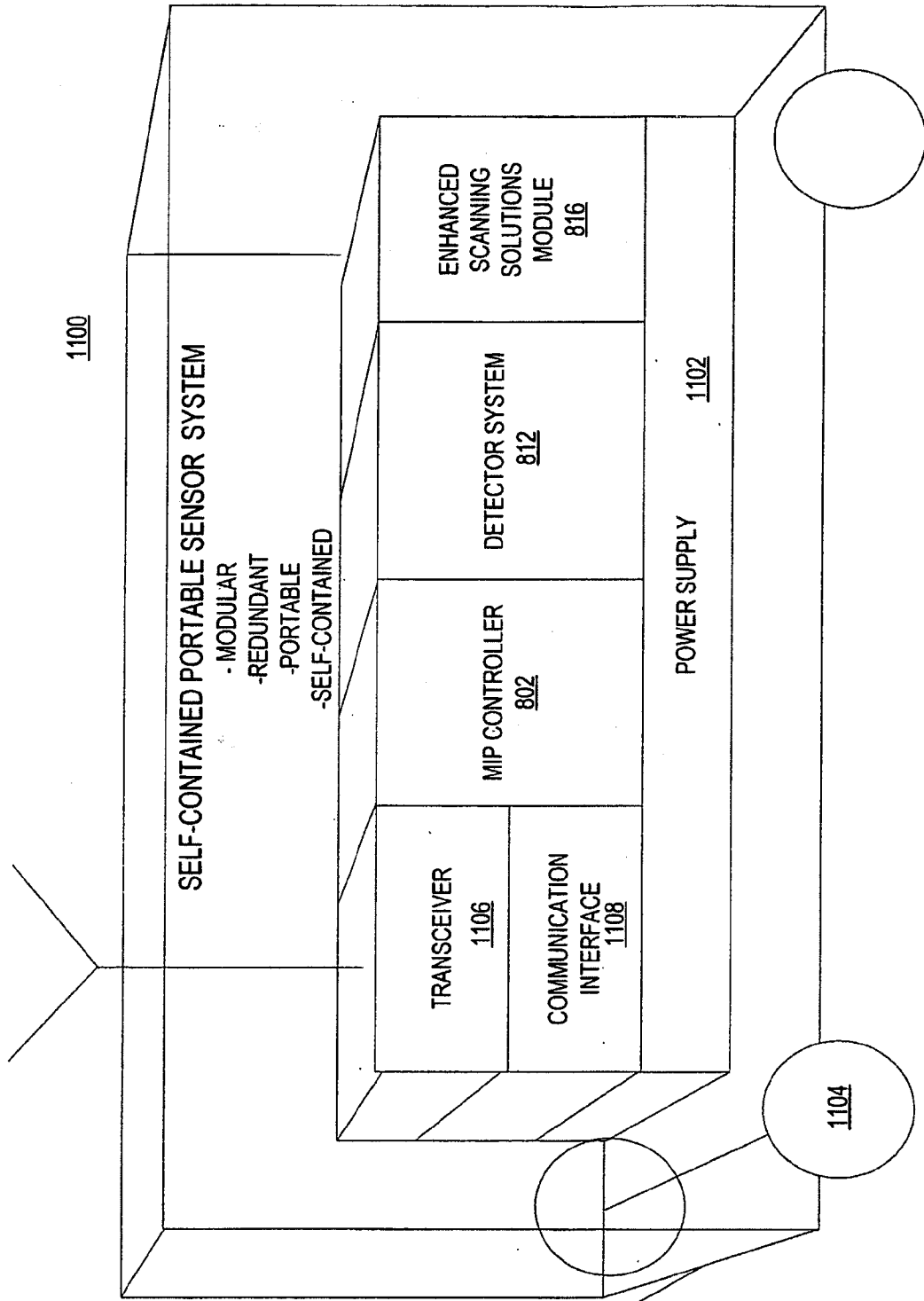

FIG. 11



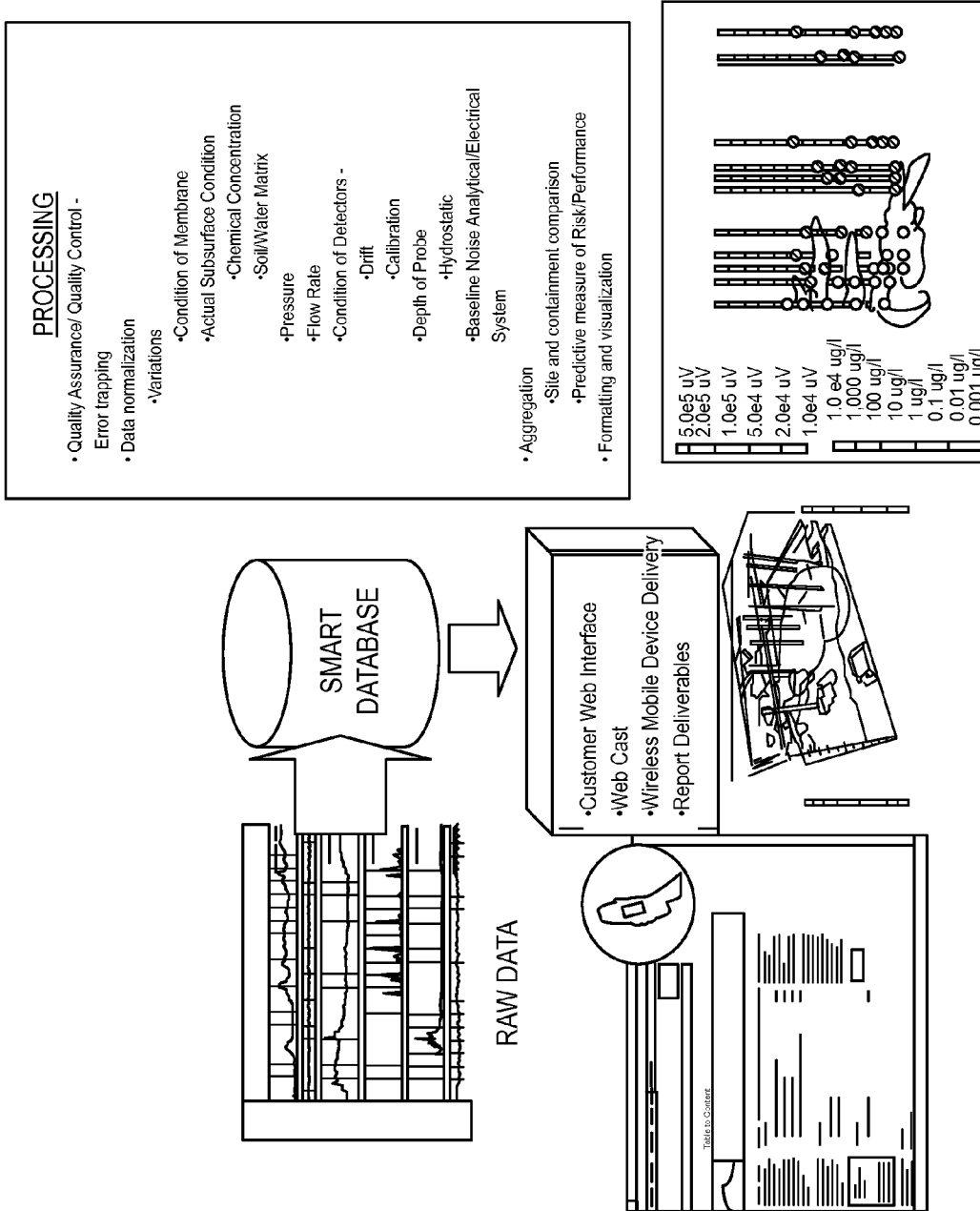

FIG. 12A

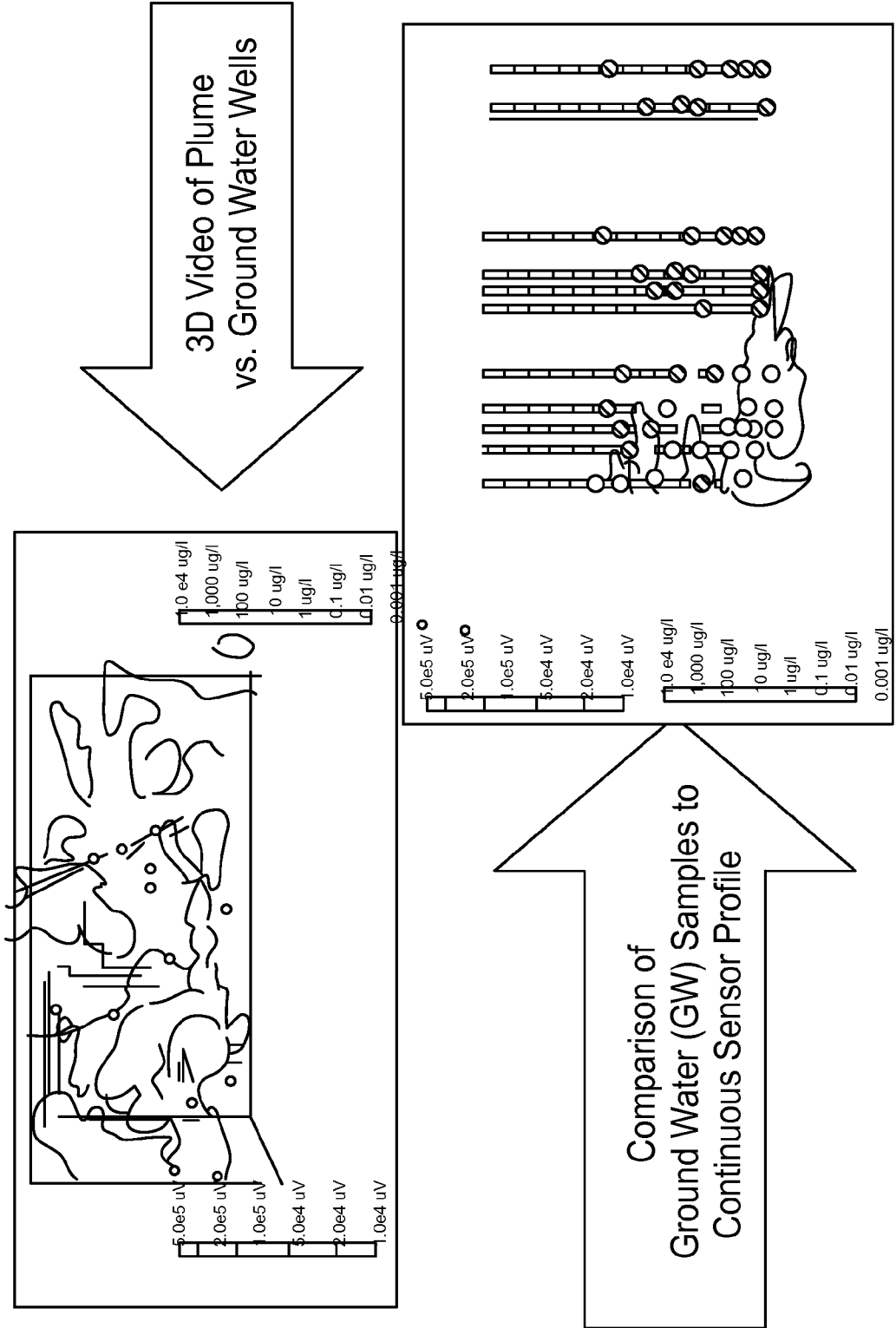
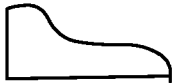

FIG. 12B

## Demo Corp



Demo Corp

SmartData Solutions TM

### Featured Projects

[>] SmartData Solutions was used to delineate a source area under a manufacturing building. The resulting 3D images helped to focus remedial efforts, thereby saving time and cost. Earth Tech's client remarked, "This was the best data he had ever seen!" Dave Rosecrance of Oak Ridge, Tennessee was asked by the TDEC to present the results at there Haz Waste conference in Gatlinburg, Tennessee in May 2002.

Contact Legal Privacy

Welcome back **John Smith**

[Not John Smith - Click Here](#)

### Your Current Projects

PETROLEUM TERMINAL  
MANUFACTURING FACILITY

### Other Demo Corp Projects

Brownfield Site

Irving Lambert - San Francisco

Dry Cleaner

Anna Cohen - Tampa

Gas Station

Vernon Wilkes - Baltimore

Vapor Intrusion Site

Sam Fisher - Dallas

### Assistance

#### Customer Services

We strive to provide all our customers with the best service possible. If you are experiencing a problem, please do not hesitate to call our customer service department toll-free on 1-888-344-2704.

FIG. 12C

# Demo Corp

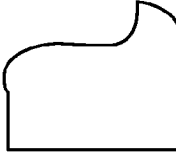

Your Projects

## Manufacturing Facility

SmartData Solutions TM

[>] Completed Deliverables  
As your order is completed each item will be added to this screen. Your sidemap is still available by clicking on the "Sitemap" heading below.

You can get this content delivered to you on a CDROM, Please contact your sales representative or the SmartData Solutions TM Team for assistance.

### Site Information

Manufacturing Facility  
Savanna, GA  
Project Dates

Started: 8/12/2002

Complete: 8/21/2002  
Status

Completed

### Movie Information

[>] Play the movie  
The Movies AVI files contained on this CD can be viewed with Microsoft Media Player. In the event the movie does not play, you may need the appropriate decompression software.

We have enclosed this software on the CD. To install this software, simply run the file and select "Install" when prompted.



[>] Use another Media Player then what comes with Windows

As an alternative to Media Player, we have included a view called Cantasia Player that can be installed free of charge. This is in our view a very good product and should be used in case Media Player fails to play the

- [>] Sitemap
- [>] Images

ECD 1+E6, Plan View (Full Size)	[71kb]
ECD 1+E6, Plan View	[71kb]
ECD 5+E6, Plan View	[66kb]
ECD 5+E5, Plan View	[71kb]
ECD Slice, Lab Data	[81kb]

### [>] Movies

(>) Plan View, 360 Fly-around (Lab Data)	[11mb]
(>) Plan View, 360 Fly-around (Full site)	[41mb]

### [>] Presentations

(0) SmartData Solutions TM Overview	[2mb]
-------------------------------------	-------

## Assistance

### Customer Services

We strive to provide all our customers with the best service possible. If you are experiencing a problem, please do not hesitate to call our customer service department toll-free on 1-888-344-2704.

### Webcast



- CPT01CP2
- PGCPT01
- PGCPT02
- PGCPT03
- PGCPT04
- PGCPT05
- PGCPT06
- PGCPT07
- PGCPT08
- PGCPT08C
- PGCPT09
- PGCPT11
- PGCPT12
- PGCPT15
- PGCPT18
- PTCPT1CP
- PGCPT23
- PGCPT24
- PGCPT25
- PGCPT26
- PGCPT27
- PGCPT29

### Resource

# FIG. 12D

The Images below were selected during the LIVE Webcast. Each Image can be selected as the basis for a movie and to be included in a report. Refer to the check boxes to the right of the Image for all the options available for that image.

---

Previous Order Exist  
 A previous order exists for this webcast. You can add to this order by selecting more Deliverables and click "Update Order". To remove items from the existing order, uncheck the items and click "Update Order". Previously ordered items are listed in Red for clarity.

---

Oblique Views

<p>Click to enlarge</p>	SOIL ..... [not shown] PID ..... [not shown] FID ..... [not shown] ECD ..... 1.0e+006uV	<input type="checkbox"/> Include in Report <input checked="" type="checkbox"/> Electronic Image <input type="checkbox"/> Create Basic Movie
View: Looking North (N) Comment: Lab		
<p>Click to enlarge</p>	SOIL ..... [not shown] PID ..... [not shown] FID ..... [not shown] ECD ..... 5.0e+005uV	<input type="checkbox"/> Include in Report <input type="checkbox"/> Electronic Image <input type="checkbox"/> Create Basic Movie
View: Looking West (W) Comment: Lab		
<p>Click to enlarge</p>	SOIL ..... [not shown] PID ..... [not shown] FID ..... [not shown] ECD ..... 5.0e+006uV	<input type="checkbox"/> Include in Report <input checked="" type="checkbox"/> Electronic Image <input type="checkbox"/> Create Basic Movie
View: Looking North (N) Comment: Lab		

FIG. 12E

**SMART DATA SUBSURFACE DATA  
REPOSITORY SYSTEM, METHOD AND  
COMPUTER PROGRAM PRODUCT**

CROSS-REFERENCE TO RELATED  
APPLICATIONS

**[0001]** This application is a continuation of co-pending U.S. patent application Ser. No. 10/666,557, Attorney Docket No. 36507-193187 entitled "Smart Data Subsurface Data Repository System, Method and Computer Program Product," to Sohl, et al. filed on Sep. 23, 2002, of common assignee to the present invention the contents of which are incorporated herein by reference in their entirety.

**[0002]** U.S. patent application Ser. No. 10/666,557 claims priority to U.S. Provisional Patent Application No. 60/412,575, Attorney Docket No. 36507-191464 entitled "System, Method and Computer Program for Subsurface Contamination Detection and Analysis," to Sohl, et al. filed on Sep. 23, 2002, of common assignee to the present invention, the contents of which are incorporated herein by reference in their entirety;

**[0003]** U.S. patent application Ser. No. 10/666,557 is related to the following co-pending U.S. patents, the contents of which are incorporated herein by reference in their entirety:

**[0004]** U.S. Pat. No. 7,221,171, issued May 22, 2007, Attorney Docket No. 36507-193186, entitled "Enhanced Subsurface Membrane Interface Probe (MIP)," to Sohl, et al. filed on Sep. 22, 2003, of common assignee to the present invention;

**[0005]** U.S. Pat. No. 7,058,509, issued Jun. 6, 2006, Attorney Docket No. 36507-191465, entitled "System, Method and Computer Program Product for Subsurface Contamination Detection and Analysis," to Sohl, et al. filed on Sep. 22, 2003, of common assignee to the present invention; and

**[0006]** U.S. Pat. No. 7,425,307, issued Sep. 16, 2008, Attorney Docket No. 36507-193188, entitled "Enhanced Subsurface Scanning System, Method and Computer Program Product," to Sohl, et al. filed on Sep. 22, 2003, of common assignee to the present invention.

BACKGROUND OF THE INVENTION

**[0007]** 1. Field of the Invention

**[0008]** The present invention relates generally to subsurface area contamination analysis systems, and more particularly to a smart data acquisition, processing and analysis tool used in the contamination area assessment and cleanup decision-making process.

**[0009]** 2. Related Art

**[0010]** Large, complex environmentally impaired or contaminated sites present difficult and potentially expensive challenges for proper characterization and cleanup. Often extensive assessment efforts leave property owners and the engineering consultants with more questions than answers. Equally difficult is ascertaining the level of legal and financial liability associated with contaminated sites resulting in delays in restoring properties to economic viability. The two biggest questions being: "One, what liability does a property owner have as a result of environmental contamination?" and "Can we realistically cleanup this site within our budget?"

**[0011]** In today's technological climate, the availability of advanced sensors, telecommunications, computational power and visualization software has dramatically changed

the way information is collected, decisions are made, and engineering systems are designed. For example, diagnostic tools such as Magnetic Resonance Imaging (MRI) coupled with intelligent databases provide radiologists and surgeons with a detailed understanding of conditions within the human body prior to invasive surgery or treatments. Furthermore, coupling real time sensors with high speed telecommunications enables medical professionals to perform surgery using robotics remotely from as far away as another continent.

**[0012]** The above examples are just a few among the many instances of how today's technological advances have changed the medical and scientific community. These examples also significantly change the business economics of diagnosing medical conditions and providing state of the art treatment anywhere in the world, thus leveraging the knowledge and talent of a small number of experts. A similar concept can be applied to the assessment and cleanup of environmentally contaminated or impaired properties. Simply stated, more complete and detailed information provided simultaneously to all parties involved in the assessment, risk analysis, engineering design, and decision-making process of dealing with contaminated properties, leads to making better decisions, at a decreased risk and lower cost.

**[0013]** Conventionally, the investigation of most environmentally contaminated sites involves an extended process including the preparation of written work plans by an environmental consultant, approval by a property owner and regulatory agencies, field investigation, laboratory analyses, and written findings of results and recommendations. This process is extremely slow (months to years) and labor intensive. The outcomes are generally subject to much questioning resulting in a repetition of the process to obtain additional information. The burden of proof placed on the property owner and the owner's environmental consultant in competition with the high cost of data acquisition results in an incomplete assessment, increased risk as a result of incomplete information, and incorrectly designed and applied cleanup tools.

**[0014]** The problem is compounded by the high cost of data acquisition and correlation. Most data are collected by the intrusive sampling of soil cores, groundwater, and vapor from the subsurface using drill rigs and direct push technology. These processes typically yield 5-30 samples per day for subsequent analysis by field instruments or remote fixed laboratories. In consideration of the high cost of mobilizing heavy equipment and personnel to collect the samples, budget constraints often limit the total number and amount of samples obtained, and thus the completeness of the data set for a particular site.

**[0015]** Furthermore, samples are typically obtained at predetermined locations and at predetermined depths specified by a presumed level of understanding on the part of the environmental consultant of the field geology. Most often, inadequate consideration is given to modifying the sampling plan based on the actual observed field conditions. These factors compound the limited data set considering any additional samples required to adequately delineate any identified contamination are not included in the current budget or work plan.

**[0016]** A third compounding factor in adequately assessing or characterizing property with environmental contamination using the present technology is the difficulty of effectively obtaining samples representative of the contaminant concentrations. Current soil coring and groundwater sampling

devices work reasonably well in respective ideal geological regions, but are extremely ineffective in regions of complex, heterogeneous soil conditions. Typically, saturated soil regions with large grain sizes such as sand, and those highly permeable to liquids are difficult to recover using state of the art soil coring tools. In a saturated soil region with small grain sizes such as clays and silty materials, low permeability makes groundwater samples difficult to obtain. An issue in unsaturated soil conditions is that it is difficult to get a full sample recovery, to prevent the loss of volatile compounds. Again, when samples from predetermined locations and depths are not fully recovered, the data set suffers and a level of uncertainty increases.

**[0017]** Additional elements that affect the amount and quality of information obtained during site assessments for contamination include handling and shipping errors created, transportation delays, laboratory handling errors and delays, and multiple data formats created by laboratories and various site assessment tools. Often times insufficient data is obtained to address the interaction between geology and chemical contaminant migration and degradation.

**[0018]** Once data is obtained the data is frequently displayed in incompatible tabular formats or two-dimensional diagrams. These difficult-to-use data formats result in delays in report preparation, review, and the decision making process. The net result is a slow process, difficult to use, and with a high level of uncertainty. The slow process becomes the basis for pricing, insuring, and engineering design resulting in expensive, delayed, and ineffective restoration of environmentally damaged property.

**[0019]** Therefore, given the above, what is needed is a smart data system, tools, methods and computer program product for source area contamination data acquisition, analysis and processing that allows dozens of samples to be collected and analyzed daily, producing detailed vertical profiles that can be made into transects and 3-D images of the subsurface. Further, the needed system, method and computer program product should be low-cost, rugged and accurate to produce repeatable results when operated by persons of varying degrees of knowledge and skill. The needed system should provide near real-time information useful for decision making. The desired system should aggregate collective value of data obtained on multiple sites to progressively lower the cost of restoring contaminated properties over time.

#### SUMMARY OF THE INVENTION

**[0020]** An exemplary embodiment of a system, method, and computer program product for end-to-end environmental data acquisition and delivery including the steps of: a) acquiring environmental subsurface data via direct reading sensors; b) geo-referencing the data; c) transmitting the data to a data analysis application server; and d) analyzing the data to obtain information about the data.

**[0021]** In an exemplary method, the data of step (a) can include: one or more data parameters.

**[0022]** In an exemplary method, the environmental subsurface data relates to chemical and geological attributes of the subsurface.

**[0023]** In an exemplary method, the direct reading sensors of step (a) can include: direct sensing technologies; optical sensors; chemical sensors; electromechanical sensors; membrane interface probe (MIP) sensors; advanced MIP sensors;

laser induced fluorescence (LIF) sensors; ultraviolet induced fluorescence (UVF) sensors; polymer sensors; or haloprobe sensors.

**[0024]** In an exemplary method, the where the geo-referencing of the step (b) can include: geo-referencing in at least two dimensions; or geo-referencing the data to a specific point on the earth's surface.

**[0025]** In an exemplary method, the where the at least two dimensions can include: latitude, longitude, altitude, or time.

**[0026]** In an exemplary method, the where the geo-referencing of the step (b) can include: geo-referencing in at least three dimensions.

**[0027]** In an exemplary method, the at least three dimensions can include: latitude, longitude, altitude, or time.

**[0028]** In an exemplary method, the transmitting of step (c) can include: transmitting via the Internet; or transmitting via a wireless communications link.

**[0029]** In an exemplary method, the application server of step (c) can include: an application service provider (ASP).

**[0030]** In an exemplary method, the step (d) can include: storing the data in a database; mining the data; calculating the information from the data using an algorithm; performing visualization processing in at least two dimensions; displaying a graphical visualization of the data; mapping the data; or displaying in two-dimensional or three-dimensional formats the data.

**[0031]** In an exemplary method, the wherein the step (d) can include: refining raw data into processed data; normalizing the data for variations in acquisition of the data; normalizing for condition of a membrane of a membrane interface probe (MIP); normalizing for variation of actual subsurface conditions including at least one of chemical concentration and soil water matrix; determining relative quality efficacy data including determining at least one of: pressure, flow rate, condition of detectors, drift, calibration, depth of probe, hydrostatic, and baseline noise of analytical/electrical system; storing the data; aggregating the data into aggregate data; determining predictive modeling using the aggregate data; assessing measure of risk using the aggregate data; evaluating risk using the aggregate data; calculating total mass of chemical compounds; calculating volume of affected soil and groundwater; calculating compound identification, calculating removal costs, performing sensitivity analysis, comparing data of multiple sites.

**[0032]** In an exemplary method, the step of performing a sensitivity analysis can include: displaying using a "dashboard" type display; and providing results to at least one of an office device, or a field device.

**[0033]** In an exemplary method, the method further can include: e) posting the information on a web site for access by authorized users.

**[0034]** In an exemplary method, the web site can include: a secure Internet Web site.

**[0035]** In an exemplary method, the method can further include: e) transmitting the information over a network to a mobile device. In an exemplary method, the network can include: a wireless network.

**[0036]** In an exemplary method, the method further can include: e) aggregating the data into a database; f) mining the database; g) determining predictive modeling using the aggregate data; h) assessing measure of risk using the aggregate data; i) evaluating risk using the aggregate data; j) providing the user with relative analysis of various sites based on at least one of: geological information, and contaminant con-

ditions; and k) storing the data in a database; l) grooming data; m) comparing data to at least one of: historical data, and data from other sites; n) performing datamining; or o) ranking sites.

[0037] In an exemplary method, the method further can include: e) transmitting the information including: i. transmitting the information including completed data analytics via the Internet back to source location for decision-making and process changes; or ii. transmitting the information wirelessly to a mobile device to facilitate access via Internet protocols to the information analyzed from the sensor outputs.

[0038] In an exemplary method, the method can further include: f) normalizing the data for variations in at least one of: acquisition of the data, condition of membrane of a membrane interface probe (MIP), subsurface conditions including at least one of chemical concentration and soil water matrix; or g) determining relative quality efficacy data including determining: pressure, flow rate, condition of detectors, drift, calibration, depth of probe, hydrostatic, or baseline noise of analytical/electrical system.

[0039] In another exemplary embodiment, a system, method and computer program product is set forth where the method of equipping and training licensed operators to perform sensor data acquisition at remote locations using a smart data system can include the steps of: a) charging a licensed operator a one-time setup fee to obtain a license to provide sensor data acquisition services and to obtain training; b) charging the licensed operator an ongoing subscription fee for access to and use of a smart data analysis system for transmission of data and data warehousing services; or c) charging the licensed operator an individual project fee, wherein the individual project fee varies according to the amount of analytics, display, or customer deliverables required.

[0040] In an exemplary method, the method can include transmission of the data of the step (b) can include: transmitting the data via a software link to a Web site.

[0041] In an exemplary method, the method can include the smart data analysis of the step (b) can include: using computational software including: 2D visualization or 3D visualization of geo-referenced direct reading sensor data.

[0042] In an exemplary method, the method can include the smart data analysis of the step (b) including: aggregating the data into a comparative database providing the user with relative analysis of various sites based on geological and contaminant conditions.

[0043] In an exemplary method, the data warehousing services of the step (b) can include: posting and delivering of: an interactive two-dimensional visualization; an interactive three-dimensional visualization; and engineering design data; to a Web site.

[0044] In an exemplary method, the step (c) can include: delivery of software and paper deliverables for each of the projects to at least one of: the licensed operator; or other clients with licensed access.

[0045] In another exemplary embodiment, an enhanced membrane interface probe is set forth. In an exemplary embodiment, a membrane interface probe apparatus can include: a membrane interface probe (MIP) sensor having a larger diameter than a conventional MIP sensor.

[0046] In an exemplary system, the enhanced MIP can be adapted for direct coupling to larger diameter rod systems.

[0047] In an exemplary system, the enhanced MIP can allow use of the MIP sensor with larger capacity push and hammer systems.

[0048] In an exemplary system, the enhanced MIP can allow use in situations where a low sidewall support of the drive rod string exists.

[0049] In an exemplary system, the enhanced MIP can be adapted to include two or more permeable membranes.

[0050] In an exemplary system, the enhanced MIP can include: a membrane interface probe (MIP) sensor having two or more permeable membranes.

[0051] In an exemplary system, the enhanced MIP is disclosed where the two or more permeable membranes are arranged equidistant about a circumference of the MIP sensor.

[0052] In an exemplary system, the enhanced MIP is disclosed where the MIP sensor is operative to improve circumferential sensing and to increase likelihood of collection of volatile organic mass by the MIP sensor.

[0053] In an exemplary system, the enhanced MIP is disclosed where the membrane interface probe apparatus includes a membrane interface probe (MIP) sensor adapted to improve watertight integrity by including undersea cabling electrical couplings and O-ring mechanical couplings.

[0054] In an exemplary system, the enhanced MIP is disclosed where the MIP is a modular membrane interface probe (MIP) apparatus including: a modular membrane interface probe (MIP) sensor constructed from a plurality of modular components allowing field serviceable replacement of any malfunctioning components of the plurality of modular components.

[0055] In an exemplary system, the modular MIP is disclosed including: an external barrel having a cavity; or (or throughout means and/or, i.e., a logical or operation) an inner core barrel assembly field-insertable into the cavity having a heater cavity, where the heater cavity is adapted to receive a field-insertable removable cartridge heating element.

[0056] In an exemplary system, the enhanced MIP is disclosed where the modular MIP apparatus can include a removable conductivity nose assembly.

[0057] In an exemplary system, the enhanced MIP is disclosed where the MIP apparatus includes a field-insertable removable cartridge heating element.

[0058] In an exemplary system, the enhanced MIP is disclosed where the modular MIP apparatus can include a waterproof electrical connector and/or an o-ring seal.

[0059] In an exemplary system, the enhanced MIP is disclosed where the membrane interface probe apparatus can include: a membrane interface probe (MIP) sensor including a removable trap directly into the probe for the collection and concentration of volatile organic compounds.

[0060] In an exemplary system, the enhanced MIP is disclosed where the removable trap enables detection of lower levels of concentration of the volatile organic compound, and specific identification of compounds through post run chromatographic analysis.

[0061] In an exemplary system, the enhanced MIP is disclosed where the MIP further can include: providing for calibration of the MIP sensor using chromatographic methods.

[0062] In an exemplary system, the enhanced MIP is disclosed where the MIP can further include means for simultaneous trapping and concentrating of volatile organic compounds during MIP sampling and logging events.



[0063] In an exemplary system, the enhanced MIP is disclosed where a membrane interface probe apparatus can include: a membrane interface probe (MIP) sensor including a heated transfer line from a body of the MIP sensor to a surface detector suite minimizing loss of volatile organic compounds in a cold transfer line.

[0064] In an exemplary system, the enhanced MIP is disclosed where a membrane interface probe apparatus can include: a membrane interface probe (MIP) sensor including an enhanced scanning solutions module, and a sample introduction system adapted to reduce overall equipment footprint and cost; to introduce calibration gases; and to allow for simultaneous sampling of volatile organic gas stream for immediate chromatographic analysis.

[0065] In an exemplary system, the enhanced MIP is disclosed where a membrane interface probe apparatus can include: a membrane interface probe (MIP) sensor including a global positioning system (GPS) receiver integrated with a data acquisition system adapted to allow simultaneous georeferencing of sampling points with sample data.

[0066] In an exemplary system, the enhanced MIP is disclosed where a membrane interface probe system can include: a membrane interface probe (MIP) sensor including a mobile device in wireless communication with a data acquisition system enabling near real-time transfer of data from the MIP sensor to a base station.

[0067] In an exemplary system, the enhanced MIP is disclosed where the mobile device can include a graphical display and control module adapted to operate the data acquisition system operation.

[0068] In an exemplary system, the enhanced MIP is disclosed where the mobile device is portable.

[0069] In an exemplary system, an enhanced scanning solutions module is disclosed including a flow control subsystem; a detector subsystem coupled to the flow control subsystem; a dryer/moisture separator subsystem coupled to the flow control subsystem; a sampling subsystem coupled to the flow control subsystem; a software control subsystem coupled to the flow control subsystem, the detector subsystem, the dryer/moisture separator subsystem, or the sampling subsystem.

[0070] In an exemplary system, an enhanced scanning solutions module is disclosed where the sampling subsystem can include: a sample loop; an absorbent trap; and a gas chromatography injection port.

[0071] In an exemplary system, an enhanced scanning solutions module is disclosed where the module further include an exhaust; a pneumatic supply; a power supply; a bypass module; a feedback signal; or a pressure control subsystem.

[0072] In another exemplary system, an enhanced scanning solutions module is disclosed where the enhanced scanning solutions module can include: a detector subsystem; a sampling subsystem; a software control subsystem coupled to the detector subsystem, and the sampling subsystem.

[0073] In an exemplary system, the enhanced scanning solutions module further includes a dryer/moisture separator subsystem coupled to the software control subsystem.

[0074] In an exemplary system, the enhanced scanning solutions module can include the sampling subsystem including: a sample loop; an absorbent trap; a gas chromatography injection port.

[0075] In an exemplary system, the enhanced scanning solutions module further includes: an exhaust; a pneumatic supply; a power supply; a bypass module; a feedback signal; or pressure control subsystem.

[0076] In an exemplary system, the enhanced scanning solutions module can include on-the-fly reconfigurability, and can further include: a plurality of operator-selectable modes.

[0077] In an exemplary system, the enhanced scanning solutions module can further include: a plurality of pre-programmable operating modes that interactively reconfigures to perform any of a plurality of functions, subject to particular conditions.

[0078] In an exemplary system, the enhanced scanning solutions module can further include: an interface between the detector subsystem and a gas handling subsystem allowing insertion of: a sample, another detector, a flowpath, a flow path rate, a dryer, an exhaust, a feedback, or a trap.

[0079] In an exemplary system, the enhanced scanning solutions module, the software control subsystem can include: a data logger; a sequencer; a valve control system; a monitor; a display; or a recording function.

[0080] Further features and advantages of the present invention, as well as the structure and operation of various embodiments of the present invention, are described in detail below with reference to the accompanying drawings.

#### BRIEF DESCRIPTION OF THE DRAWINGS

[0081] Various exemplary features and advantages of the invention will be apparent from the following, more particular description of exemplary embodiments of the present invention, as illustrated in the accompanying drawings wherein like reference numbers generally indicate identical, functionally similar, and/or structurally similar elements. The left most digits in the corresponding reference number indicate the drawing in which an element first appears.

[0082] FIG. 1 depicts an exemplary embodiment of a block diagram illustrating an environmental data acquisition and delivery process according to an exemplary embodiment of the present invention;

[0083] FIG. 2 depicts an exemplary embodiment of a block diagram illustrating a business process according to an exemplary embodiment of the present invention;

[0084] FIG. 3 depicts an exemplary embodiment of an exemplary window or screen shot, generated by a graphical user interface (GUI) of the present invention, showing a remediation foot print of a site;

[0085] FIG. 4A depicts an exemplary embodiment of a high level schematic diagram illustrating a membrane interface probe (MIP) significantly redesigned according to an exemplary embodiment of the present invention;

[0086] FIG. 4B depicts an exemplary embodiment of a detailed level schematic diagram illustrating a membrane interface probe (MIP) significantly redesigned according to an exemplary embodiment of the present invention, having a cross-sectional view of an exemplary modular MIP including two cross-sections and a sector cross-section;

[0087] FIG. 4C depicts an exemplary embodiment of a detailed level schematic diagram illustrating a membrane interface probe (MIP) significantly redesigned, and illustrating an inner core barrel assembly having O-Ring grooves, according to an exemplary embodiment of the present invention;

[0088] FIG. 4D depicts an exemplary embodiment of a detailed level schematic diagram illustrating an exemplary external barrel assembly of an enhanced membrane interface probe (MIP) significantly redesigned according to an exemplary embodiment of the present invention;

**[0089]** FIG. 5 depicts an exemplary embodiment of a block diagram of an exemplary computer system useful for implementing the present invention;

**[0090]** FIG. 6 depicts an exemplary embodiment of a workflow process according to an exemplary embodiment of the present invention;

**[0091]** FIG. 7 depicts an exemplary embodiment of an overall smart data system process according to the present invention;

**[0092]** FIG. 8A depicts an exemplary embodiment of a MIP system including a MIP probe, a controller, a detector and a data acquisition module according to the present invention;

**[0093]** FIG. 8B depicts an exemplary embodiment of an improved MIP system including an enhanced MIP probe, a controller, an enhanced scanning solutions module detector system, data acquisition module, and an enhanced smart data system according to the present invention;

**[0094]** FIG. 9A depicts a diagram illustrating an exemplary embodiment of a conventional detection system according to the present invention;

**[0095]** FIG. 9B depicts a high level diagram illustrating an exemplary embodiment of an enhanced scanning solutions module according to the present invention;

**[0096]** FIG. 9C depicts a more detailed version of an exemplary embodiment of exemplary enhanced scanning solutions functionality according to the present invention;

**[0097]** FIG. 10A depicts an exemplary embodiment of a system hardware architecture providing an exemplary enhanced smart data analysis client-server system according to the present invention;

**[0098]** FIG. 10B depicts an exemplary embodiment of an application service provider (ASP) embodiment of an exemplary embodiment of the enhanced smart data analysis system including exemplary subsystem modules according to the present invention;

**[0099]** FIG. 11 depicts an exemplary embodiment of an exemplary self-contained portable sensor system according to the present invention;

**[0100]** FIG. 12A depicts a diagram illustrating an exemplary embodiment of the Smart database system according to the present invention;

**[0101]** FIG. 12B depicts a diagram illustrating an exemplary embodiment of output from the Smart database system according to the present invention;

**[0102]** FIG. 12C depicts a graphical user interface of a browser illustrating an exemplary embodiment of a web logon window of a Demo Corporation providing access to the Smart database system according to the present invention;

**[0103]** FIG. 12D depicts a graphical user interface of a browser illustrating an exemplary embodiment of a web window depicting exemplary deliverables for a Manufacturing Facility of a Demo Corporation providing access to graphical renderings on the Smart database system according to the present invention; and

**[0104]** FIG. 12E depicts a graphical user interface of a browser illustrating an exemplary embodiment of a browser window depicting exemplary selectable deliverables according to the present invention.

#### DESCRIPTION OF AN EXEMPLARY EMBODIMENT OF THE INVENTION

**[0105]** A preferred exemplary embodiment of the invention is discussed in detail below. While specific exemplary embodiments are discussed, it should be understood that this

is done for illustration purposes only. A person skilled in the relevant art will recognize that other components and configurations can be used without parting from the spirit and scope of the invention. The present invention meets the above-identified needs by providing a system, method and computer program product for source area contamination data acquisition, analysis and processing.

**[0106]** The method and computer program product of the present invention allow clients to reap the benefits of recent advances in sensor technology, rapid computational analysis and wireless data delivery to more quickly and reliably: create a diagnostic image of the hydrogeology and contamination under a site, assess the transaction and health risks of a property, avoid downstream costs, and complete a transaction or close files on a site in a shorter amount of time than conventionally possible. The smart data process is capable of collecting far more data per day than conventional approaches, provides data in near real-time that can be used to make timely decisions, and provides the data in easy-to-use formats.

**[0107]** In an exemplary embodiment, the smart data system is utilized to expedite the reliable characterization of the subsurface. Site assessments can be more effectively accomplished because the smart data produced by the present invention are of higher resolution so fewer interpretive mistakes will be made, are available immediately, and can be processed and mapped on a daily basis. Thus, results can be used to direct the next day's activities. The smart data system according to an exemplary embodiment of the present invention can also dramatically reduce the costs of remediation because the system provides a more focused picture of the chemical occurrences relative to site hydrogeology.

**[0108]** In an exemplary embodiment, the smart data system includes a database for storing aggregate data collected from multiple sites. In an exemplary embodiment, the smart data system takes raw data, accumulates data from the MIP system, from gas chromatographic analysis, from geographic position, from other sensors, and other data sets. The smart data system can process raw data to refine the data, can normalize for variations in acquisition, and can perform quality assurance analysis on the data.

**[0109]** The processing to normalize for variations can, e.g., compensate for drift in performance or condition of the membrane, and for variations actual subsurface conditions such as, e.g., chemical concentration, and the soil water matrix. Processing can include analysis of the relative quality and efficacy of the data. The processing system can analyze and account for variations in pressure, flow rate, condition of detectors (can account for drift and can calibrate, e.g., using a tracer gas), depth of the probe (hydrostatic), and in the baseline noise due to the analytical/electrical system.

**[0110]** The data can be mined and processed including, e.g., use of 3D visualization technology, and can be delivered in near real-time to the field for access by field personnel via, e.g., an application service provider (ASP), a web-based interface, and wireless device access. Video can be used to illustrate changes over time.

**[0111]** Data can be aggregated from multiple sites, and can be used as a predictive measure of risk and performance.

#### I. OVERVIEW

**[0112]** The present invention provides a system, method and computer program product for source area contamination data acquisition, analysis and processing.

**[0113]** Organizations including property owners, lending institutions, insurance underwriters, and consulting engineers—see lower costs, shorter project cycle times, and an acceleration of regulatory and financial underwriting approvals.

**[0114]** As mentioned above, traditional environmental investigation and cleanup economics have been driven by the high cost and delays of data acquisition. This leads to poorly designed and expensive engineering approaches and ineffective cleanup. The smart data tool of the present invention provides ten to a hundred times more data at a fraction of the time and costs. More critically, smart data analysis, presentation and reporting services turn this data into high-impact, decision oriented information with a net benefit of 30-50% lower cost for the property owners and a better quality outcome, more quickly.

**[0115]** The present invention provides multiple levels of value creation:

**[0116]** Property Owners—lower cost of investigation and cleanup, faster cycle time, & lower insurance costs;

**[0117]** Consulting Engineers—10 to 100 times more data which results in more effective cleanup at lower cost;

**[0118]** Insurance Underwriters—more detailed information which results in less uncertainty and risk;

**[0119]** Service Partners—significant increase in sales at higher margin; and

**[0120]** Strategic Sponsors—access to a large number of highly qualified service providers of cutting-edge technology.

**[0121]** In addition, the present invention's approach substantially lowers the uncertainty associated with environmental characteristics of a property. This, in turn, accelerates property transactions and lowers the premiums for environmental insurance. Research into this market driver indicates that 40 to 60% of environmental insurance premiums and escrow requirements stem from uncertainty in the environmental assessment. The smart data provides a comprehensive quantification and easily understood 3-D representation of the environmental conditions (see FIG. 3), which substantially increases the clarity and visibility of potential problems, improves decisions, and lowers risk.

**[0122]** The present invention is now described in more detail herein in terms of the above examples. This is for convenience only and is not intended to limit the application of the present invention. In fact, after reading the following description, it will be apparent to one skilled in the relevant art(s) how to implement the following invention in alternative embodiments. For example, the present invention can be used for the in-site performance monitoring of remediation of volatile organic compounds by combining in-situ sensors, geo-referenced positioning, wireless transfer of data to a base station, transfer of data via the Internet, computational software, and display on an interactive web site.

**[0123]** The present invention can also be used to acquire large amounts of geo-referenced data on the chemical and physical parameters of inland water bodies. This data can in turn be used to monitor biological ecosystems, environmental contamination, and compliance with discharge requirements for ships and vessels.

## II. SYSTEM OPERATION

### A. Process

**[0124]** The method and computer program product of the present invention employs a unique end-to-end process of

environmental data acquisition and delivery as illustrated in FIG. 1. FIG. 1 depicts in an exemplary embodiment, an exemplary process in which one or more of the following steps can be performed:

**[0125]** 1. Acquisition of data parameters using direct reading sensors in-situ.

**[0126]** 2. Geo-referencing each data parameter to a specific point on the earth's surface so as to generate a geographically referenced sensor array as shown in step 102.

**[0127]** 3. Transmission of the data parameters via, e.g., one or more communications network link such as, e.g., wireless communication link as shown in step 104, and transmission over a network such as, e.g., the Internet as shown in step 106 to a database at, e.g., an Application Service Provider (ASP), for analysis and display, making use of communications links and storage for later access and query in a database via a database interface as shown in step 108.

**[0128]** Performance of data analytics and processing including calculations, visualization in graphic formats, mapping, and display in two-dimensional and three-dimensional formats, making use of analytical/computational software as shown in step 110, and creating interactive 2D, 3D, and n-D (such as, e.g., time-lapsed video) visual outputs as shown in step 112. Additional calculations can also include, e.g., total mass of chemical compounds, volume of affected soil and groundwater, compound identification, removal costs, and/or sensitivity analysis using a "dashboard" type display. In an exemplary embodiment, the smart data system can include a database for storing raw data, analyzed data, and aggregate data collected from multiple sites. The reader is referred to, e.g., FIGS. 1, 8B, 10B, and 12A, for a more detailed discussion regarding the smart data system according to the present invention. In an exemplary embodiment, the smart data system can take raw data, such as, e.g., accumulating data from the MIP system, from gas chromatographic analysis, from geographic position, from other sensors, and from other data sets. The smart data system can process raw data to refine the data, can normalize for variations in acquisition, and can perform quality assurance analysis on the data. The processing to normalize for variations can, e.g., compensate for drift in performance or condition of the membrane, and for variations actual subsurface conditions such as, e.g., chemical concentration, and the soil water matrix. Processing can include analysis of the relative quality and efficacy of the data. The processing system can analyze and account for variations in pressure, flow rate, condition of detectors (can account for drift and can calibrate, e.g., using a tracer gas), depth of the probe (hydrostatic), and in the baseline noise due to the analytical/electrical system. The data can be mined and processed including, e.g., use of 3D visualization technology from step 112, and can be delivered in steps 114, 116, 118 in near real-time to the field for access by field personnel via, e.g., an application service provider (ASP), a web-based browser interface, and a wired or wireless communication device access. Video can be used to illustrate changes over time.

**[0129]** 4. The aggregation of data into a comparative database, making use of the database interface as shown in step 108, and providing the user with relative analysis of various sites based on geological and contaminant conditions, including interactive display as shown in step 114. Data can be aggregated from multiple sites, and can be used as a predictive measure of risk and performance.

**[0130]** 5. Posting of the completed data analytics for interactive access via, e.g., a secure Internet Web site, and for viewing by approved individuals, can be provided as also shown in step **114**.

**[0131]** 6. Transmissions of the completed data analytics via, e.g., the Internet, back to the source location for decision-making and process changes, can be provided as shown in step **116**.

**[0132]** 7. The use of wireless communication devices to facilitate connection of the sensor outputs to the Internet can be provided in an exemplary embodiment as shown in steps **104, 118**. Of course a wired communications link can be used to the extent that such a link is available.

#### B. Business Process

**[0133]** In an exemplary embodiment, an entity may utilize a business process to implement and offer for sale services utilizing the smart data system, method and computer program product of the present invention. An exemplary embodiment of this business process is illustrated in FIG. **2** including performing one or more of the following steps:

**[0134]** 1. Equipping and training licensed operators (“users”) **202** to perform sensor data acquisition at remote locations using the smart data system. These operators, in an exemplary embodiment, can pay a one-time setup to obtain a license and training; an ongoing subscription fee for access to the present invention’s analytical software and data warehousing services; and/or individual project fees, which can vary according to the amount of analytics, display, and customer deliverables required. The licensed operators **202** can provide data acquisition and transmission services for a fee, or for a share in revenues.

**[0135]** 2. Transmission of the data through a software link to a Web site operated by the entity can be provided as shown using a proprietary software link **208**, in an exemplary embodiment.

**[0136]** 3. Data analysis by the entity using computational software according to the methodology of the present invention can be performed as shown by licensor **204**. In an exemplary embodiment, the data can be analyzed using analytical software. In another exemplary embodiment, an application service provider (ASP) model may be employed as shown, and as discussed further below, with reference to FIG. **10B**. The services of the ASP can be used in exchange for a fee paid to the ASP, in an exemplary embodiment. The fee can be a one time fee, a periodic fee, a bundled fee, and/or a subscription fee.

**[0137]** 4. The aggregation of data into a comparative database such as, e.g., the Columbia Technologies’ Environmental Comparables Knowledgebase (ECK) available from Columbia Technologies, LLC of Halethorpe, Md., U.S.A., providing the user with relative analysis of various sites based on geological and contaminant conditions can be performed by licensor **204**.

**[0138]** 5. Posting and delivery of interactive two-dimensional and three-dimensional visualizations (such as, e.g., those shown in FIG. **3** in 3D visualization **300** having one dimension in the x-direction represented by x-axis **308**, another dimension in the y-direction represented by y-axis **314**, another dimension in the z-direction represented by z-axis **306**) and key engineering design data to an interactive Web site **206** can be operated by the entity and can be performed by licensor **204**. The visualizations and data can be accessed via a browser as shown in **210** using, e.g., an Internet

browser, and/or a hyper text markup language (HTML) link, for example. The visualizations can include, e.g., as shown in FIG. **3**, geo-referenced locations on a 3D spatial map indicating from where the MIP probe samples were obtained. Color-coding may be employed as indicated in color band indicator **310**. Geographic information system renderings, trans-sections, 360 degree fly-around movies, volumetric calculations, 3D surface area contour mapping, 3D videos of a contaminant plume vs. a ground water (GW) well, graphical comparisons of a GW samples to continuous sensor profile may be employed as methods of displaying the data.

**[0139]** 6. Delivery of software, visual displays, engineering data, and paper deliverables for each project to licensed clients **206** and/or other clients with licensed access.

#### C. Enhanced Membrane Interface Probe (MIP)

**[0140]** In an exemplary embodiment of the present invention, a Membrane Interface Probe (MIP) available from GEOPROBE SYSTEMS, INC. of Salina, Kans., USA and described in U.S. Pat. No. 5,639,956, (the ’956 patent) the contents of which are incorporated herein by reference in its entirety, can be used as part of the smart data system to transport volatile organic compounds from the geological subsurface to the surface for measurement using chemical detectors. An exemplary embodiment of an improved MIP **402** is described below with reference to FIGS. **4A-4D**. The MIP described in the ’956 patent can include a dipole electrical conductivity sensor **410** for the measurement of conductivity in-situ as an indicator of soil grain size. The probe may be driven or hammered into the geological subsurface using hydraulic or pneumatic reaction weight or hammers.

**[0141]** FIG. **4A** depicts, in an exemplary embodiment of the present invention, a MIP **400** enhanced to include a number of useful features. Of course, in alternative exemplary embodiments of the present invention, MIP **400** can be modified to include any combination of a number of useful features outlined below. For example, in an exemplary embodiment of the present invention, the MIP **400** can be significantly redesigned and enhanced to incorporate one or more of the following advantageous features as depicted in FIG. **4A**.

**[0142]** 1. In an exemplary embodiment, the enhanced MIP **400** can include an outer barrel assembly **402**, which can include a larger diameter probe (2.125-inches) as illustrated in diagram **400** of FIG. **4** than conventionally available for direct coupling to larger diameter rods **403**. The large diameter rods **403** can significantly increase the yield strength of the drive rod string allowing for the rods’ use with stronger push/hammer systems and in situations where there is low sidewall support of the drive rod string.

**[0143]** 2. In an exemplary embodiment, the enhanced MIP probe **400** can be redesigned in a modularized in removable, multi-subsystem, field-replaceable fashion as shown in **4A-4D**. As shown, MIP **400** can include the external barrel assembly **402** depicted in detail in FIG. **4D**, including a cavity into which can be tightly coupled an inner core barrel assembly **404**, which is depicted in greater detail in FIG. **4C**. The inner core barrel assembly **404** can be fashioned to receive a field replaceable cartridge heater element **406**. The heater **406** is used to heat the zone around membranes **408**, described further below. MIP **400** is also enhanced to include various external watertight connections **412**. Watertight connections **412** include various components taken from underwater cabling applications. The watertight connections **412** include bulkhead electrical connector **410**, inline electrical connector

**414** and splice **416**. Bulkhead electrical connector **410** can be a SEA CON LSG-6-BC-HP, and inline electrical connector **414** can be a SEA CON RMG-6-FS inline connector, both available from SEA CON Brantner & Associates Inc., of San Diego, Calif., USA. Also shown are external vapor connections, including gas vapor subassembly **422** and inlet and outlet gas ferrell connections **424**. The MIP **400** is enhanced to include a removable conductivity probe nose assembly **418** having dipoles **426** and thread **428** as well as cap screws **430** holding the nose assembly **418** in place when coupled to the outer barrel assembly **402**. Diagram **460** of FIG. 4D includes a detailed level schematic diagram illustrating an exemplary external barrel assembly lengthwise cross-section (top), side cross-section A-A (middle left) of an exemplary three permeable membrane embodiment, a sector cross-section of an o-ring port at an exemplary permeable membrane (detail A), and a exterior view of an exemplary permeable membrane (bottom middle) and detail B, of enhanced MIP **400**.

[0144] 3. In an exemplary embodiment, the enhanced MIP **400** can include an increased number (two or more) of permeable membranes **408** as compared to conventional MIP probes such as the single permeable membrane **408** shown in the '956 patent. As illustrated in the exemplary embodiment of FIG. 4A, two or more permeable membranes **408**, such as, e.g., three (**408a**, **408b**, **408c** as shown in FIGS. 4A and 4B) to provide for greater circumferential sensing and the potential for double, triple, or more times as much volatile organic mass to be collected by the probe **402** in each given time period. In the exemplary embodiment depicted in FIG. 4B, permeable membranes **408a**, **408b**, and **408c** can provide improved circumferential coverage than conventional versions of MIP probes **400**. Diagram **440** of FIG. 4B illustrates an exemplary embodiment including exemplary manufacturing tolerances and a cross-section of the enhanced MIP probe **400**. Diagram **440**, in an exemplary embodiment includes two cross-sections illustrating exemplary vapor connecting ports (on the left middle) and an exemplary tri-permeable membrane embodiment (labeled site detail A, on the right middle) of the present invention, and a sector cross-section illustrating an exemplary O-ring port (labeled Detail A) and single permeable membrane. This increase in mass flow can significantly improve detection capability of the probe **400** over predecessor probes. For example, with 3 gas permeable membranes instead of 1, can yield triple the mass transfer into the probe. O-ring port **420** can accommodate an O-ring such as, e.g., MS16142 O-Ring available from PARKER HANNIFIN CORPORATION, O-Ring Division, of Lexington, Ky., U.S.A. The inner core barrel assembly **404** as shown in FIG. 4C is made to receive the heater element **406**, allowing for expansion. FIG. 4C depicts diagram **450**, in an exemplary embodiment, including a side view (at bottom), and two cross-sections A-A (middle), and B-B (top), respectively, illustrating the inner core barrel assembly **404** having O-Ring grooves for gas passages, where the O-rings serve to seal the gas passages.

[0145] 4. In an exemplary embodiment, the enhanced MIP **400** can include an incorporated watertight integrity through a major redesign of the probe body and mechanical couplings **424** and electrical couplings **410**, **411**, **416** because water intrusion has been identified as a major contributor to premature probe failure.

[0146] 5. In an exemplary embodiment, the enhanced MIP **400** can include a simpler design to allow for field repairs and replacement of individual components (e.g., the heater sys-

tem **416**). Currently, failure of any component of conventional probes require complete replacement of the probe increasing the cost of operation and delay. As noted above, the various modules and subsystems of enhanced probe **400** allow field replacement of failing components.

[0147] 6. In an exemplary embodiment, the enhanced MIP **400** can include integrating small removable traps directly into the probe for the collection and concentration of volatile organic compounds. The removable trap feature can allow for lower (better) detection levels of compounds as well as the specific identification of compounds through post run chromatographic analysis.

[0148] 7. In an exemplary embodiment, the enhanced MIP **400** can include incorporating a heated transfer line from the probe body to the surface detector suite to minimize the current loss of volatile organic compounds in the cold transfer line. As shown, the probe can have a custom heater element **406** with a through conductor and ground conductor. A heater cartridge insert **406** can be provided.

[0149] 8. In another exemplary embodiment, the enhanced MIP **400** can include a detector suite, and sample introduction system specifically configured for the MIP application. This feature can reduce the overall equipment footprint and cost; allow for the introduction of calibration/tracer gases; and allow for the simultaneous sampling of the volatile organic gas stream for immediate chromatographic analysis. See FIGS. 9A and 9B below and the discussion with reference to these figures of the enhanced scanning solutions module.

[0150] 9. In an exemplary embodiment, the enhanced MIP **400** can include an integrated global positioning system (GPS) receiver along with the data acquisition system to allow for simultaneous positioning of sampling points with the sample data for the volatile organic compounds. A smart integrated GPS probe can allow easier closely integrated georeferencing of captured sample data.

[0151] 10. In yet another exemplary embodiment, the enhanced MIP **400** can include integrating a wireless data transfer communication device with the data acquisition system to allow for near real time transfer of data to a base station for subsequent analysis and display. In an exemplary embodiment, the wireless data transfer communication device can include transceiver hardware for wireless transmission. A communications protocol software application suite stack can accompany the transceiver hardware feature to provide various functions. In an exemplary embodiment, the wireless communications device can be compliant with an IEEE standard 802.11 wireless local area network. In another exemplary embodiment, other wireless hardware and software protocols can be used such as, e.g., ultrawideband (UWB), cellular, global system for mobile telephone (GSM), code division multiple access (CDMA), orthogonal frequency division multiple access (FDMA), cellular digital packet data (CDPD), or other wireless protocols and technologies.

[0152] 11. In an exemplary embodiment, the enhanced MIP **400** can include providing for a mobile computing/communications device that can be in an exemplary embodiment, handheld, and can include a graphical display and control module for system operation and data acquisition. The mobile computing/communications device feature enhances the operator's mobility during field sampling events. In one exemplary embodiment, the mobile device can be a portable device such as, e.g., the self-contained portable sensor system illustrated in FIG. 11.

**[0153]** 12. In an exemplary embodiment, the enhanced MIP **400** can include providing for the simultaneous trapping and concentration of volatile organic compounds during MIP sampling and logging events. The simultaneous trapping and concentration of volatile compounds can allow for near real-time specific identification of the volatile organic compounds detected.

**[0154]** 13. In an exemplary embodiment, the enhanced MIP **400** can include providing for calibration of the probe system using chromatographic methods such as internal standards.

#### D. Project Management

##### **[0155]** CAPABILITIES:

**[0156]** Web Interface

**[0157]** User-based access levels

**[0158]** Maintain multiple projects

**[0159]** Maintain Project History

**[0160]** Create new projects

**[0161]** Upload files

**[0162]** Communicate with field computer in real-time

**[0163]** The solution to the challenges mentioned above is an intelligent project maintenance, data acquisition and analysis process. The process of the present invention can be done by combining a variety of technologies and procedures in a novel manner. A complete solution spans from project maintenance to final result presentation. No such solution conventionally exists prior to the present invention.

**[0164]** Project maintenance is available through a Web interface. This interface allows the project manager to create new jobs and to upload project information for distribution to field computers using technologies such as, e.g., wireless communications links. The web interface can also serve as a centralized project plan (“project central”) for the project managers. At the web interface, the project managers can follow the progress of a job on an up-to-the-minute basis, allowing the project managers to make critical changes and adjustments to the project plan in a real-time environment. Changes made to the project plan can be immediately propagated into the field via communications links to mobile devices such as wireless field computers. Project managers can maintain an infinite number of projects simultaneously through the web interface.

**[0165]** A main feature of the web interface can include a status “dashboard” which can display to the project manager exactly how the project is proceeding at a glance. The system can also include email notifications triggered by project changes where the email notifications can be put into effect, alerting the project manager of changes. Field personnel can also communicate problems and request replacement parts through the web interface, making the web interface the complete solution for remote project maintenance.

#### E. Sensor and its Connection to the Field Computer

##### **[0166]** CAPABILITIES:

**[0167]** Web Interface

**[0168]** To fill the need for more complete information at the point of sampling, project information can be accessible in the field on a mobile device, such as, e.g., a wireless handheld computer. Information such as site maps can be available to the operator of the mobile device at the touch of a button. This information can also be remotely updated by the project manager using the web interface. The field operator can also make ad hoc changes to the project on-the-fly as needed. These

changes will be transmitted back to the project management site where an alert can be issued to the project manager. The ability to make field decisions without losing project plan cohesiveness is a vital component of a complete solution.

**[0169]** During the data collections process, the operator can be guided by the field computer that serves as an expert system, conveying “best practices” to any operator regardless of experience. The operator can have full access to all site information including the locations of the proposed sampling points. The advanced sensor equipment can interface to the field computer during the collections process, providing visual feedback and data storage/retrieval.

#### F. Link to Global Positioning Satellite (GPS) Receiver

##### **[0170]** CAPABILITIES:

**[0171]** Sub-meter accuracy

**[0172]** Altitude

**[0173]** Communications through standard personal computer (PC) communications ports (COM (RS-232 serial), LPT (parallel), USB (universal serial bus))

**[0174]** Streaming location data

**[0175]** During the data collections phase, the field computer can also be linked to a global positioning system (GPS) antenna. The GPS can allow the field operator to accurately locate any predefined locations that are part of the pre-loaded site plan. Of course alternative location positioning systems can be used using conventional approaches such as, e.g., triangulation, and satellite transmitter location systems. The GPS can also provide the ability to adjust locations due to unexpected obstacles without losing location accuracy in the final output. The GPS capability can also negate the need for the site to be surveyed by a 3rd party, as is conventionally the norm absent the present invention, thus providing time and cost reductions to the overall process. The GPS data can be transmitted along with all collected data as a complete package. The packaged information can then be incorporated in the “dashboard” on the web interface to show progress.

**[0176]** By providing altitude information along with geographic two-dimensional (2D) coordinates, typography can be added to the three-dimensional (3D) images, resulting in a more “realistic” picture of the site and its below-ground behavior. An exemplary 3D visualization rendering is provided from an exemplary embodiment of the present invention in FIG. 3 of the present invention.

#### G. Data Transmission Process

##### **[0177]** CAPABILITIES:

**[0178]** Hypertext transfer protocol (HTTP) POST

**[0179]** HTTP GET

**[0180]** Transmission control protocol/Internet Protocol (TCP/IP)

**[0181]** Simple mail transfer protocol (SMTP)

**[0182]** File transfer protocol (FTP)

**[0183]** Data can be transmitted via a communications network **1004** as shown in FIG. 10A. The data can be transmitted over a wireless communications link where available. If wireless access is not available, the system can equally connect to the main system via any conventional method including, e.g., a dialup connection, or other direct network connection with accompanying protocol communications software applications suite. Due to the various wireless communications technologies available, a one-size-fits-all approach is not desir-

able. The solution in an exemplary embodiment of the present invention, includes a comprehensive open software international (OSI) layer 4, transport layer TCP built on a standards-based protocol suite to utilize the inherent capabilities of whatever wireless device and network is being used. The OSI layer 2, link layer, such as Ethernet, or other media access control (MAC) protocols can therefore be largely ignored and thus can make the approach of the present invention largely immune to changing technologies. The transport protocol layer is based on standard Internet protocols, the transmission control program (TCP). Since push capabilities do not exist on all data networks, polling by the field computer can be employed as a means to acquire updated information from the main system.

#### H. Database

##### [0184] CAPABILITIES:

- [0185] Relational Database
- [0186] Support for standard structured query language (SQL) query tools
- [0187] Support for open database connectivity (ODBC) compliant databases
- [0188] Scalability
- [0189] Once new data has been transmitted to the main system, the data can be stored in the database under its parent project. All data can be organized in a parent/child relationship. (Customer->Project->Data)

#### I. Analysis

##### [0190] CAPABILITIES:

- [0191] Modular
- [0192] Remove Baseline Drifts
- [0193] Normalize data between samples
- [0194] Output to Database
- [0195] Multi-pass analysis for "smoothing" of results
- [0196] Pattern recognition
- [0197] Cross Analysis with external data
- [0198] Site, Geology, and Chemistry Comparisons
- [0199] Risk Evaluation and Assessment
- [0200] Analysis of the data can occur when sufficient amounts of data have been collected. This process can be governed by a user-defined setting in the project and can be stored in the database. The field operator can also request seatrain types of analysis to be made on-the-fly, to guide the decision making process. Depending on the type of data collected, a number of data "normalization" processes can be executed. The normalization processes can be designed to correct data for such anomalies such as, e.g., "drifting baseline," "change in temperature," "peak to baseline height," "conductivity," and "atmospheric pressure." The normalization processes can produce more accurate results and can be a vital step in the process. Not normalizing results can lead to a varying degree of confidence and thus can create an environment where the findings could be misleading.
- [0201] The normalization process can use historical data for reference and can thus become more accurate with a larger number of samples.
- [0202] 3D analyses can include volumetric probability calculations like "kriging" and surface area contour mapping. All analyzed data can be stored in the database under the parent project and can be added to the "dashboard" for comparative analysis by the project manager. Once analysis of the data has been completed the project manager can have a new

set of tools available through the web interface. Using these tools such questions as "How much overburden must be removed to reach the source area?" can be answered.

[0203] The analysis process takes into account all relevant information provided in the project. To gain further refinement of the results, the project manager can upload such information as ground water tables and geological data. The project manager can "force" new analysis at any time to include newly uploaded information.

#### J. 3-Dimensional Visualization, Display

##### [0204] CAPABILITIES:

- [0205] Display volumetric data in form of "plumes"
- [0206] Transparency of objects
- [0207] Overlay computer aided design (CAD) drawings and other geographic information system (GIS) file formats
- [0208] Calculate volume and mass
- [0209] Drill-down information popup
- [0210] Convex hull grid
- [0211] North directional arrow
- [0212] Overview window (birds-eye view)
- [0213] Custom selectable colors
- [0214] Coloring based on confidence
- [0215] Object-based editing
- [0216] Image output in, e.g., BMP, JPG, TIF extension image formats
- [0217] The project manager can select a number of "pre-defined" 3D visualizations, graphics, outputs through the web interface. These standard "views" can be produced automatically by the 3D modeling software once the analysis process is complete. The views can then be made available to the project manager through the web interface. Another option available to the project manager can be to have an expert produce custom "views" from the data collected. The expert can use a specially designed graphical user interface (GUI) to produce 3D objects from the data produced by the analysis process. The GUI can provide an easy and fast environment in which the expert can drag and drop visual elements onto the "presentation screen" to accomplish tasks. Each object can have a number of behaviors or properties. After being added to the presentation screen the expert can manipulate the output through these capabilities.
- [0218] The interface can allow the expert to create "screen shots" of the presentation screen at any time. These screen shots can be saved as both images (e.g., bitmaps) and "presentation objects" which can be manipulated in 3D. These 3D objects can be rotated and zoomed using a viewer, but can only be altered by the expert. This can provide a very powerful way to distribute 3D images as it allows the end user to fine tune the view and to insure visibility of vital information.
- [0219] The 3D modeling system can also produce high quality movies in all major formats (e.g., MPEG, AVI, MOV, etc.). Output can be provided electronically over the web, or on a compact disk-read only memory (CD-ROM) or digital versatile disk (DVD) depending on user preference.

#### K. Interactive Presentation

##### [0220] CAPABILITIES:

- [0221] Server/client communication over TCP/IP
- [0222] Real-time remote manipulation
- [0223] Save data on both server and client
- [0224] Permission based Client manipulation

- [0225] Read Database through ODBC
- [0226] ActiveX
- [0227] Support 56 kps connection speed
- [0228] Object inventory based on available data
- [0229] Multiple clients connecting to one server
- [0230] Multiple client screen resolutions shown on server
- [0231] Client Connection dashboard on sever
- [0232] A vital part of the 3D modeling process is the interaction by the end user. Through a live interface between the end user's "client software" and the expert's "server software," the end user can play an active role in the creation of the final product. The link between the two systems can run over a TCP/IP connection. The end user can see the same screen output as viewed by the expert and can have the ability to manipulate the objects on the screen to insure a collaborative result. The expert can be responsible for the introduction of new screen elements such as grid line and contamination plumes. Each resulting "screen shot" can be saved in the customer's inbox and can be immediately available on the end user's system as well. This data can now be available for view and re-distribution at any time by the end user. Information about the produced screen shots can be saved in the database and can become the basis for billing.

#### L. Mobile Device

##### Handheld Mobile Computer

[0233] The mobile device, also referred to as a field computer, serves a number of purposes. First and foremost it is the link between the collected data and the main system, but it is also a tool to be used by the field operator. It includes guides and "best practices" approaches to field operations. Through the 3D feedback mechanism, the operator will have visibility of the results from the analysis and 3D modeling right in the field. The analysis data will be returned timely enough to be used in the selection of the next sample location, thus giving the operator the advantage of only addressing locations that are deemed vital to the results.

[0234] Analyses returned to the field computer include "next location" suggestions along with calibration information produced by the normalization process. The ability to make field decisions in real-time is a great time and cost saver. Examples of the field computer can include any mobile device such as, e.g., a desktop, notebook, laptop, subnotebook, tablet or handheld personal computers (PCs), or personal digital assistants (PDAs). The field computer **500a** in an exemplary embodiment, can be in wireless communication with a base station computer **500b** (collectively computers **500**). In an exemplary embodiment, the mobile device **500a** can communicate with the base station computer device **500b** using any of a number of well known wireless communications software protocols, transceiver hardware, networks and communications link technologies such as, e.g., an Infrared Data Association (IrDA)-compliant wireless technology, or a short range radio frequency (RF) technology such as, e.g., a Bluetooth-compliant wireless technology, an IEEE standard 802.11-compliant wireless local area network (LAN) such as, e.g., an IEEE standard 802.11a, b, or g, wireless LAN, a Shared Wireless Access Protocol (SWAP)-compliant wireless technology, a wireless fidelity (Wi-Fi)-compliant wireless technology, or an ultra wide band (UWB) wireless technology network. Although mobile device **500a** and base station computer device **500b** have been described as coupled

to one another, the devices **500a, b** need not be directly connected to one another, and can instead be coupled by any of various conventional physical network technologies such as, e.g., routers, bridges, gateways, transceivers, antennae and cables.

### III. EXAMPLE IMPLEMENTATIONS

[0235] The present invention (or any part(s) or function(s) thereof) may be implemented using hardware, software or a combination thereof and may be implemented in one or more computer systems or other processing systems. In fact, in one exemplary embodiment, the invention is directed toward one or more computer systems capable of carrying out the functionality described herein. An example of a computer system **500** is shown in FIG. 5. FIG. 5 depicts an exemplary embodiment of a block diagram of an exemplary computer system useful for implementing the present invention. Specifically, FIG. 5 illustrates an example computer **500** in a preferred embodiment is a personal computer (PC) system running an operating system such as, e.g., Windows 98/2000/XP, Linux, Solaris, OS/2, Mac/OS, or UNIX. However, the invention is not limited to these platforms. Instead, the invention can be implemented on any appropriate computer system running any appropriate operating system, such as Solaris, Irix, Linux, HPUX, OSF, Windows 98, Windows NT, OS/2, Mac/OS, and any others that can support Internet access. In one exemplary embodiment, the present invention is implemented on a computer system operating as discussed herein. An exemplary computer system, computer **500** is shown in FIG. 5. The mobile device **500a** can be a communications device or computing device such as, e.g., a tablet personal computer (PC), a handheld PC, a handheld running WINDOWS MOBILE for POCKET PC operating system, a sub-notebook PC a notebook PC, a laptop PC, a personal digital assistant (PDA), or other device such as a desktop PC or workstation. Although mobile device **500** in an exemplary embodiment is described as mobile, the device need not be mobile, and can actually be stationary. The base device **500b** can be another mobile device, a desktop computer, or some other source of data that can be synchronized with the data on the mobile device **500a**.

[0236] Other components of the invention, such as, e.g., a computing device, a communications device, a telephone, a personal digital assistant (PDA), a pocket personal computer (PC), a handheld personal computer (PC), client workstations, thin clients, thick clients, proxy servers, network communication servers, remote access devices, client computers, server computers, routers, web servers, data, media, audio, video, telephony or streaming technology servers could also be implemented using a computer such as that shown in FIG. 5.

[0237] The computer system **500** includes one or more processors, such as processor **504**. The processor **504** is connected to a communication infrastructure **506** (e.g., a communications bus, cross-over bar, or network) Various software embodiments are described in terms of this exemplary computer system. After reading this description, it will become apparent to a person skilled in the relevant art(s) how to implement the invention using other computer systems and/or architectures.

[0238] Computer system **500** can include a display interface **502** that forwards graphics, text, and other data from the communication infrastructure **506** (or from a frame buffer not shown) for display on the display unit **530**.



[0239] The computer system 500 also includes a main memory 508, preferably random access memory (RAM), and a secondary memory 510. The secondary memory 510 can include, for example, a hard disk drive 512 and/or a removable storage drive 514, representing a floppy diskette drive, a magnetic tape drive, an optical disk drive, a compact disk drive CD-ROM, etc. The removable storage drive 514 reads from and/or writes to a removable storage unit 518 in a well known manner. Removable storage unit 518, also called a program storage device or a computer program product, represents a floppy disk, magnetic tape, optical disk, compact disk, etc. which is read by and written to by removable storage drive 514. As will be appreciated, the removable storage unit 518 includes a computer usable storage medium having stored therein computer software and/or data.

[0240] In alternative exemplary embodiments, secondary memory 510 may include other similar devices for allowing computer programs or other instructions to be loaded into computer system 500. Such devices may include, for example, a removable storage unit 522 and an interface 520. Examples of such may include a program cartridge and cartridge interface (such as, e.g., those found in video game devices), a removable memory chip (such as, e.g., an erasable programmable read only memory (EPROM), or programmable read only memory (PROM) and associated socket, and other removable storage units 522 and interfaces 520, which allow software and data to be transferred from the removable storage unit 522 to computer system 500.

[0241] Computer 500 can also include an input device such as (but not limited to) a mouse or other pointing device such as a digitizer, and a keyboard or other data entry device (none of which are labeled).

[0242] Computer 500 can also include output devices, such as, for example, display 530, and display interface 502. Computer 500 can include input/output (I/O) devices such as, e.g., communications interface 524, cable 528 and communications path 526. These can include, e.g., a network interface card, and modems (neither are labeled). Communications interface 524 allows software and data to be transferred between computer system 500 and external devices. Examples of communications interface 524 may include a modem, a network interface (such as, e.g., an Ethernet card), a communications port, a Personal Computer Memory Card International Association (PCMCIA) or PCCard-compliant slot and card, etc. Software and data transferred via communications interface 524 are in the form of signals 528 which may be electronic, electromagnetic, optical or other signals capable of being received by communications interface 524. These signals 528 are provided to communications interface 524 via a communications path (e.g., channel) 526. This channel 526 carries signals 528 and may be implemented using wire or cable, fiber optics, a telephone line, a cellular link, an radio frequency (RF) link and other communications channels.

[0243] In this document, the terms “computer program medium” and “computer usable medium” are used to generally refer to media such as, e.g., removable storage drive 514, a hard disk installed in hard disk drive 512, and signals 528. These computer program products provide software to computer system 500. The invention is directed to such computer program products.

[0244] Computer programs (also called computer control logic), including object oriented computer programs, are stored in main memory 508 and/or the secondary memory

510 and/or removable storage units 514, also called computer program products. Such computer programs, when executed, enable the computer system 500 to perform the features of the present invention as discussed herein. In particular, the computer programs, when executed, enable the processor 504 to perform the features of the present invention. Accordingly, such computer programs represent controllers of the computer system 500.

[0245] In another exemplary embodiment, the invention is directed to a computer program product comprising a computer readable medium having control logic (computer software) stored therein. The control logic, when executed by the processor 504, causes the processor 504 to perform the functions of the invention as described herein. In another exemplary embodiment where the invention is implemented using software, the software may be stored in a computer program product and loaded into computer system 500 using removable storage drive 514, hard drive 512 or communications interface 524. The control logic (software), when executed by the processor 504, causes the processor 504 to perform the functions of the invention as described herein.

[0246] In yet another embodiment, the invention is implemented primarily in hardware using, for example, hardware components such as application specific integrated circuits (ASICs), or one or more state machines. Implementation of the hardware state machine so as to perform the functions described herein will be apparent to persons skilled in the relevant art(s).

[0247] In yet another exemplary embodiment, the invention is implemented using a combination of both hardware and software.

[0248] FIG. 6 depicts an exemplary embodiment of diagram 600 illustrating an exemplary workflow process according to an exemplary embodiment of the present invention. The workflow process of diagram 600 includes workflow between a field operator 602, a SmartData Workflow Administrator 604, a 3D Lab 606, a Website 608, and a customer user 610. The workflow process of diagram 600 begins with a field operator 602 from which MIP data is uploaded to website 608 as shown in step 612. From Website 608, data is retrieved by SmartData Workflow Administrator 604 as shown in step 614. From SmartData Workflow Administrator 604, a graphical MIP log is generated and uploaded to client login section of the website 608 as shown in step 616. Meanwhile MIP data is appended to the database for statistical analysis in step 618 and as shown in step 620, a start of analysis is requested of the 3D Lab 606. 3D Lab 606 performs statistical analysis in step 622. Various kinds of statistical analyses can be performed as will be apparent to those skilled in the relevant art(s). Processing can include, e.g., calculating means, standard deviations, Kriging, correlation analysis, interpolations, extrapolations, etc. Then 3D lab 606 can generate 3D models as shown in step 624. Then 3D Lab 606 can web-cast with the client customer user 610 to fine tune 3D models as shown in step 626. Then a final deliverable can be created as shown in step 628 by 3D Lab 606. Then the 3D Lab 606 can upload the deliverable to the client login section of the website 608 as shown in step 630. Then the 3D Lab 606 can provide a notification of completion to SmartData Workflow Administrator 604 as shown in step 632. Then the SmartData Workflow Administrator 604 can provide notification to customer user 610 of completion and availability of data on the client login section of the website as shown in step 634. Finally,

SmartData Workflow Administrator **604** can provide delivery of a hardcopy (if applicable) to customer user **610** as shown in step **636**.

[0249] FIG. 7 depicts an exemplary embodiment of a diagram **700** illustrating an overall smart data solutions architecture system process according to the present invention. Smartdata solutions workspace **702** includes database applications **712**, math applications **714**, 3D applications **716**, and comparables database **718**. The Smartdata solutions workspace **702** also includes a web interface **710** for communication of information to service partner workspace **704**, via wireless interface **710**. The service partner workspace **704** includes smartdata software **720**, strategic sponsor equipment **722**, and commercial equipment **724**. The Customer workspace **706** can also interact with Smartdata solutions workspace **702** as represented by the bidirectional arrows indicated in diagram **700**. Customer workspace **706** includes risk evaluation **726**, follow-on project design **728**, and regulatory review **730**.

[0250] FIG. 8A depicts an exemplary embodiment of a diagram **800** of an exemplary, conventional MIP data acquisition system according to the present invention. The exemplary MIP system of diagram **800** includes a MIP probe **810** (e.g., the MIP disclosed in the '956 patent), a MIP controller **802**, a detector system **804** and a data acquisition module **806** coupled to both the MIP controller **802** and detector system **804**. The MIP probe **810** is coupled to MIP controller **802** and detector system **804**, by a trunk line and connections **808**. The data acquisition module **806** takes its inputs and outputs data typically in the form of a data stream.

[0251] FIG. 8B depicts an exemplary embodiment of a diagram **810** of an improved MIP environmental data acquisition and analysis system according to an exemplary embodiment of the present invention. The improved MIP system of diagram **810** includes an enhanced MIP probe **400** coupled to MIP controller **802** and detector system **814**, by a trunk line and connections **808**. The detector system **814** is enhanced to include an enhanced scanning solutions module detector system **816** described further below with reference to FIGS. 9A and 9B. The detector system **814** and MIP controller **802** are again coupled to data acquisition module **806**. The output of the data acquisition module **806** is coupled to an enhanced smart data analysis system **702** as shown in diagram **810**. The enhanced smart data analysis system **702** can receive other input sensors **818**, which may, or may not be from sensors integrated into the MIP probe **812**. Examples of other sensors **818** include, e.g., laser induced fluorescence (LIF), ultraviolet induced fluorescence (UVF), polymer, and haloprobe. The enhanced smart data analysis system **702** can also receive other input data sets such as, e.g., energetics (explosives) data, computer aided design (CAD) drawing data, ground water (GW) data (see FIG. 12B) and geographic information systems (GIS) data.

[0252] FIG. 9A depicts an exemplary embodiment of a diagram **900**, illustrating functionality of a conventional detection system. The detection system of diagram **900** begins with a trunk line **808** coupling a MIP (not shown) to a dryer **914**. The dryer **914** is conventionally coupled to the detector **804**. The detector is in turn coupled to an exhaust **916**. Unfortunately, the conventional system is limited, inflexible and sequential in its processing as compared to the present invention as depicted in and described further below with reference to FIGS. 9B and 9C.

[0253] FIG. 9B depicts an exemplary embodiment of a high level diagram **901** illustrating an enhanced scanning solutions module **816** according to the present invention. The enhanced scanning solutions module **816** provides such features as, e.g., automating the detector process including software control, electronics, flow control, and pneumatic systems. The enhanced scanning solutions module **816**, in an exemplary embodiment, can provide for operator selection, sample analysis leading to chemical speciation, lower detector levels, and performance with compounds not conventionally achievable. The enhanced scanning solutions module **816**, in an exemplary embodiment, can receive as input the trunk line **808** with carrier gas from the MIP **400** as shown in FIG. 8B. The enhanced scanning solutions module **816**, in an exemplary embodiment, can include several subsystems including one or more of, e.g., a dryer input/output subsystem **902**; a loop input/output subsystem **904**; a trap input/output subsystem **906**; a flow rate control subsystem **908**; a pressure control subsystem **910**; and a detector selection subsystem **912**.

[0254] FIG. 9C depicts an exemplary embodiment of a detailed level diagram **913** illustrating an enhanced scanning solutions module **816** according to the present invention. The enhanced scanning solutions module **816** can receive from the MIP **400**, a carrier gas on trunk line **808**, at the flow rate control system **908**. The flow rate control system **908** can include such functionality as one or more of, e.g., signal processing, electrical/pneumatic valve control, switching valves, manual mode switch, and software controls. The flow rate control system **908** can allow custom workflow by selecting in or out particular detection subsystems. Exemplary subsystems can include, e.g., detector subsystem **912**, a bypass module **911**, dryer/moisture separator subsystem **902**, sampling subsystem **918**, pressure control subsystem **910** and pressure sources **909**, pneumatic supply subsystem **908**, exhaust **916**, software control subsystem **905**, and power supply **915**.

[0255] The sampling subsystem **918** in an exemplary embodiment can include any of, e.g., sample loop(s) **920**, absorbent traps **922**, and gas chromatographic injection ports **921**. In an exemplary embodiment, the sampling subsystem can be software controlled.

[0256] To calibrate the system, in an exemplary embodiment, an optional calibration material such as, e.g., a tracer gas can be run through the system and results can be measured and analyzed, and used for calibration, and for normalization procedures.

[0257] The detector subsystem **912**, in an exemplary embodiment, can include any of various detectors, such as, e.g., gas chromatography, infrared (IR), Fourier transform infrared (FTIR) spectroscopy, and chemical detectors. The detector subsystem can be coupled to exhaust **916**, pressure control subsystem **910**, software control system **905**, as well as the flow control system **908**. From the output of detector **812**, an input is provided to exhaust **916**. From sampling module **918**, an output is provided as input to sample loop **920** and concentration trap **922**.

[0258] The bypass module **911** can, e.g., bypass detection.

[0259] The dryer/moisture separator subsystem **902** can be used to bring in or out the dryer and by being software controllable, can be incorporated into processing on an ad hoc basis, as selected by the user.

[0260] The pressure control subsystem **910** and pressure sources **909** can provide back pressure to the system. Pressure

can be added to any of the processes including, e.g., the detector subsystem **912**, a bypass module **911**, dryer/moisture separator subsystem **902**, and sampling subsystem **918**.

[0261] The pneumatic supply subsystem **908** can include, e.g., purified He or Ni, and can be used in valve control. The pneumatic supply subsystem **908** can be software controlled. The software control system **905** can monitor pressure, and can control outlet options.

[0262] The software control subsystem **905** can provide various functions including any of, e.g., timing, sequencing, valve control, monitoring, displaying data, logging data and recording data.

[0263] The power supply **915** can provide power to electrical components. In an exemplary embodiment, a 12 V DC battery supply can be used.

[0264] Using the enhanced scanning solutions module **816**, a user can specify a user-directed detection process. For example, output of a concentration trap can be sent to detectors, or a detector on a second system such as, e.g., a chemical analysis detector. As another example, using the present invention, use of a dryer can be optional. Thus, as these examples illustrate, a user can on an ad hoc basis direct a customized detection process, that allows for interactive changes to the detection process.

[0265] FIG. 10A depicts an exemplary embodiment of an exemplary diagram **100** illustrating a hardware system architecture according to the present invention. Diagram **100** includes a user **206a** at a mobile device **1002a** in communication over network **1004** to the enhanced smart data analysis system application servers **1010a**, **1010b** to access data on database **1008**, via web servers **1006a**, **1006b** providing an exemplary enhanced smart data analysis client-server system. If licensed, then user **206a** can gain access via software link **208** and browser link **210**. Other users archiver **206b**, viewer **206c** and collector **202**.

[0266] FIG. 10B depicts an exemplary embodiment of an enhanced smart data analysis system **702** according to the present invention. The enhanced data analysis system **702** includes an application service provider (ASP) **1010** by which a variety of users **206a** can share the use of application servers **1010a**, **1010b** of the ASP for a fee. An exemplary embodiment of the enhanced data analysis system **702** can include various subsystem modules including, e.g., a database management system **1008** and storage/retrieval/search query subsystem **1012**; processing subsystem **1014**, algorithms module **1016**, formatting module **1018**, 3D/2D visualization **1020**; and communications protocols **1022**, web delivery **1024**, webcast **1026**, field wireless delivery **1028**, and wireless receiver **1030**.

[0267] FIG. 11 depicts an exemplary embodiment of an exemplary self-contained portable sensor system **1100** according to the present invention. As illustrated, exemplary self-contained portable sensor system **1100** can include wheels **1104**, power supply **1102**, a communications interface **1108**, transceiver **1106**, MIP Controller **802**; Detector System **812**, and enhanced scanning solutions module **816**. The exemplary self-contained portable sensor system **1100** can be modular, include redundancy and fault tolerance features such as a battery backup or generator to support the power supply **1102**, is portable for ease of use in the field, and is self-contained to allow easy setup and breakdown, since minimal assembly/reassembly is required.

[0268] FIG. 12A depicts a diagram illustrating an exemplary embodiment of the Smart database system according to

the present invention. As shown in the diagram, raw data can be analyzed and processed to create output such as, e.g., the depicted illustrative graphical renderings. The database can post for browser and/or wireless mobile device accessibility various reports and deliverables.

[0269] FIG. 12B depicts a diagram illustrating an exemplary embodiment of output from the Smart database system according to the present invention. The upper left diagram illustrates an exemplary 3D video of an environmental contamination site against a ground water well data set, illustrating a combination of outside data with processed data analytics visualization renderings. The lower right diagram illustrates a comparison of ground water samples to continuous sensor profile data, illustrating another combination of outside data with processed data analytics visualization renderings.

[0270] FIG. 12C depicts a graphical user interface of a browser illustrating an exemplary embodiment of a web logon window of a Demo Corporation providing access to the Smart database system according to the present invention.

[0271] FIG. 12D depicts a graphical user interface of a browser illustrating an exemplary embodiment of a web window depicting exemplary deliverables for a Manufacturing Facility of a Demo Corporation providing access to graphical renderings on the Smart database system according to the present invention.

[0272] FIG. 12E depicts a graphical user interface of a browser illustrating an exemplary embodiment of a browser window depicting exemplary selectable deliverables according to the present invention.

[0273] The exemplary embodiment of the present invention makes reference to wireless networks. A brief discussion of various exemplary wireless network technologies that could be used to implement the exemplary embodiments of the present invention now are discussed. Exemplary wireless network technology types, include, e.g., IrDA wireless technology, metropolitan area and wide area wireless networking technologies such as, e.g., MMDS, satellite, as well as various wireless short-range radio frequency (RF) technologies such as, e.g., Bluetooth, SWAP, "wireless fidelity" (Wi-Fi), IEEE std. 802.11b, IEEE 802.11a, and 802.11g, and ultrawideband (UWB). Of course any of various other wireless technologies can also be used, and it should be understood that the examples listed are not exhaustive.

[0274] IrDA is a standard method for devices to communicate using infrared light pulses as promulgated by the Infrared Data Association from which the standard gets its name. IrDA is generally the way that television remote controls operate. Since all remote controls use this standard, a remote from one manufacturer can control a device from another manufacturer. Since IrDA devices use infrared light, they depend on being in direct line of sight with each other. Although present IrDA-based networks are capable of transmitting data at speeds up to 4 megabits per second (Mbps), the requirement for line of sight means that an access point would be necessary in each office where a user would want to synchronize, limiting the usefulness of an IrDA network in some environments. Bluetooth is an example of a shortrange wireless radio frequency (RF) emerging wireless technology promising to unify several wireless technologies for use in low power radio frequency (RF) networks. Bluetooth is not expected to replace the need for high-speed data networks between computers. Bluetooth communicates on a frequency of 2.45 giga-

hertz, which has been set aside by international agreement for the use of industrial, scientific and medical devices (ISM).

[0275] Examples of other short-range wireless RF technology include SWAP and Wi-Fi. The SWAP and Wi-Fi specifications are based on the original Institute of Electrical and Electronics Engineers (IEEE) wireless local area network (LAN) specification, known as IEEE standard 802.11. Home radio frequency (RF) (HomeRF) developed the Shared Wireless Access Protocol (SWAP) wireless standard. Wireless Ethernet Compatibility Alliance (WECA) advocates the so-called “wireless fidelity” (Wi-Fi) which is a derivative of the IEEE std. 802.11b. The original IEEE std. 802.11 designated two ways of communicating between wireless LAN devices and allowed for speeds up to 2 Mbps. Both IEEE std. 802.11 communication methods, direct-sequence spread spectrum (DSSS) and frequency-hopping spread spectrum (FHSS), use frequency-shift keying (FSK) technology. Also, both DSSS and FHSS are based on spread-spectrum radio waves in the 2.4-gigahertz (GHz) frequency range. Home RF’s SWAP combines DECT, a time division multiple access (TDMA) voice service used to support the delivery of isochronous data and a carrier sense multiple access/collision avoidance (CSMA/CA) service (derived from IEEE std. 802.11). WECA’s Wi-Fi standard provides IEEE std. 802.11b standard wireless LAN compliant wireless communication technologies.

[0276] UWB is yet another short-range RF wireless communication system making use of small pulses of energy in the time domain that in the frequency domain are spread across a very wide bandwidth and are transmitted at a very low power level that is on the order of magnitude of noise. The pulses can be encoded to carry information by, e.g., differing the timing of arrival of pulses in the time domain.

#### IV. CONCLUSION

[0277] While various embodiments of the present invention have been described above, it should be understood that they have been presented by way of example and not limitation. It will be apparent to persons skilled in the relevant art(s) that various changes in form and detail can be made therein without departing from the spirit and scope of the invention. In fact, after reading the description herein, it will be apparent to one skilled in the relevant art(s) how to implement the invention in alternative embodiments.

What is claimed is:

1. A method of providing sensor data analysis comprising:
  - a) receiving environmental subsurface data at a first computer from a first entity, wherein said environmental subsurface data is acquired at a location via moveable direct reading sensors, wherein said environmental subsurface comprises an area beneath at least one of a surface of earth, or a surface of a body of water, and wherein said moveable direct reading sensors are placed in said environmental subsurface and said moveable direct reading sensors are in direct contact with at least one of soil, water, or vapor;
  - b) analyzing said environmental subsurface data via a data analysis system to obtain information about said subsurface data, wherein said data analysis system comprises at least one of said first or a second computer; and
  - c) providing said information to a second entity via said first or second computers or a third computer, wherein the second entity is the same or different than the first entity.

2. The method according to claim 1, wherein at least one of said receiving step a) or said providing step c) comprises: receiving or transmitting said data or information via a communications link to a Web site.

3. The method according to claim 1, wherein said analyzing step b) comprises at least one of:
  - a) a two dimensional (2D) visualization or a three dimensional (3D) visualization of geo-referenced direct reading sensor data.

4. The method according to claim 1, wherein said analyzing step b) comprises:
  - a) aggregating said data into a comparative database, and obtaining a relative analysis of various sites based on at least one of geological or contaminant conditions.

5. The method according to claim 1, wherein said analyzing step b) further comprises a data warehousing service comprising:
  - a) posting or delivering to a web site at least one of an interactive two-dimensional visualization, an interactive three-dimensional visualization, or engineering design data.

6. The method according to claim 1, wherein said providing step c) further comprises:
  - a) delivery of at least one of software or paper deliverables related to said data to at least one of a licensed operator, a licensed client, or an other client with licensed access.

7. The method of claim 1, wherein said moveable direct reading sensors of step (a) comprise at least one of:
  - a) direct sensing technologies;
  - b) optical sensors;
  - c) chemical sensors;
  - d) electromechanical sensors;
  - e) membrane interface probe (MIP) sensors;
  - f) advanced MIP sensors;
  - g) laser induced fluorescence (LIF) sensors;
  - h) ultraviolet induced fluorescence (UVF) sensors;
  - i) polymer sensors; or
  - j) haloprobe sensors.

8. The method of claim 1, wherein said data comprises:
  - a) one or more data parameters.

9. The method of claim 1, wherein said environmental subsurface data relates to at least one of chemical or geological attributes of the subsurface.

10. The method of claim 1, further comprising:
  - a) geo-referencing said environmental subsurface data; and
  - b) using said information to select a next location for acquiring a next environmental subsurface data from said moveable direct reading sensors.

11. The method of claim 10, wherein said geo-referencing of said step d) comprises at least one of:
  - a) geo-referencing in at least two dimensions; or
  - b) geo-referencing said data to a specific point on the earth’s surface.

12. The method of claim 11, wherein said at least two dimensions comprise at least one of:
  - a) latitude, longitude, altitude, or time.

13. The method of claim 10, wherein said geo-referencing of said step d) comprises:
  - a) geo-referencing in at least three dimensions.

14. The method of claim 13, wherein said at least three dimensions comprise at least one of: latitude, longitude, altitude, or time.

**15.** The method of claim 1, wherein said providing comprises at least one of:

- transmitting via the Internet;
- transmitting via a communications link;
- transmitting via a wired communications link; or
- transmitting via a wireless communications link.

**16.** The method of claim 1, wherein said providing of step c) comprises providing via an application server, wherein the application server comprises at least one of:

- an application service provider (ASP); or
- a software as a service.

**17.** The method of claim 1, wherein said analyzing step b) comprises at least one of:

- storing said environmental subsurface data in a database;
- mining said environmental subsurface data;
- calculating said information from said environmental subsurface data using an algorithm;
- performing visualization processing of said environmental subsurface in at least two dimensions;
- displaying a graphical visualization of said data;
- mapping said environmental subsurface data; or
- displaying said environmental subsurface data in at least one of: two-dimensional (2D) or three-dimensional (3D) formats.

**18.** The method of claim 1, wherein said analyzing step b) comprises at least one of:

- refining raw environmental subsurface data into processed environmental subsurface data;
- normalizing said environmental subsurface data for variations in acquisition of said data;
- normalizing for a condition of a membrane of a membrane interface probe (MIP);
- normalizing for variation of actual subsurface conditions including at least one of chemical concentration or soil water matrix;
- determining relative quality efficacy data including determining at least one of: pressure, flow rate, condition of detectors, drift, calibration, depth of probe, hydrostatic, or baseline noise of analytical/electrical system;
- storing said environmental subsurface data;
- aggregating said environmental subsurface data into aggregate environmental subsurface data;
- determining predictive modeling using said aggregate environmental subsurface data;
- assessing measure of risk using said aggregate environmental subsurface data;
- evaluating risk using said aggregate environmental subsurface data;
- calculating total mass of chemical compounds;
- calculating volume of affected soil and groundwater;
- calculating compound identification;
- calculating removal costs;
- performing sensitivity analysis; or
- comparing data of multiple sites.

**19.** The method of claim 18, wherein said step of performing a sensitivity analysis comprises at least one of:

- displaying using a “dashboard” type display; or
- providing results to at least one of an office device or a field device.

**20.** The method of claim 1, further comprising:

- d) posting said information on a web site for access by authorized users.

**21.** The method of claim 20, wherein said web site comprises:

- a secure Internet Web site.

**22.** The method of claim 1, further comprising at least one of:

- d) transmitting said information over a network to a mobile device, or transmitting said information over a network to an office device.

**23.** The method of claim 22, wherein said network comprises:

- a wireless network.

**24.** The method of claim 1, further comprising at least one of:

- d) aggregating said environmental subsurface data into an aggregate database;
- e) mining said aggregate database;
- f) determining predictive modeling using said aggregate database;
- g) assessing measure of risk using said aggregate database;
- h) evaluating risk using said aggregate database;
- i) providing the user with relative analysis of various sites based on at least one of: geological information or contaminant conditions;
- j) grooming said environmental subsurface data;
- k) comparing said environmental subsurface data to at least one of: historical environmental subsurface data or environmental subsurface data from other sites;
- l) performing datamining; or
- m) ranking sites.

**25.** The method of claim 1, further comprising:

- d) transmitting said information comprising:
  - i. transmitting said information including completed data analytics via the Internet back to source location for decision-making and process changes; and
  - ii. transmitting said information wirelessly to a mobile device to facilitate access via Internet protocols to said information analyzed from said sensor outputs.

**26.** The method of claim 1, further comprising at least one of:

- d) normalizing said environmental subsurface data for variations in at least one of: acquisition of said environmental subsurface data, condition of membrane of a membrane interface probe (MIP), subsurface conditions including at least one of chemical concentration or soil water matrix; or
- e) determining relative quality efficacy data including determining at least one of: pressure, flow rate, condition of detectors, drift, calibration, depth of probe, hydrostatic, or baseline noise of analytical/electrical system.

**27.** The method of claim 1, wherein steps a)-c) are performed by a licensor and wherein the first entity is a licensed operator and the second entity is a licensed client.

**28.** A method of providing data for analysis comprising:

- a) gathering environmental subsurface data at a first computer, wherein said environmental subsurface data is gathered at a location via moveable direct reading sensors, wherein said environmental subsurface comprises an area beneath at least one of a surface of earth, or a surface of a body of water, and wherein said moveable direct reading sensors are placed in said environmental subsurface and said moveable direct reading sensors are in direct contact with at least one of soil, water, or vapor;
- b) providing said environmental subsurface data to a first entity for analysis of said environmental subsurface data via a data analysis system to obtain information about

- said subsurface data, wherein said data analysis system comprises at least one of said first or a second computer; and
- c) receiving instructions from a second entity based on said information via said first or second computers or a third computer.
- 29.** The method according to claim **28**, wherein at least one of said providing step b) or said receiving step c) comprises: receiving or transmitting said data or information via a communications link to a Web site.
- 30.** The method according to claim **28**, wherein said analysis of said providing step b) comprises: analyzing via at least one of: a two dimensional (2D) visualization or a three dimensional (3D) visualization of geo-referenced direct reading sensor data.
- 31.** The method according to claim **28**, wherein said analysis of said providing step b) comprises: aggregating said data into a comparative database, and obtaining a relative analysis of various sites based on at least one of geological or contaminant conditions.
- 32.** The method according to claim **28**, wherein said analysis of said providing step b) further comprises a data warehousing service comprising: posting or delivering to a web site at least one of: an interactive two-dimensional visualization; an interactive three-dimensional visualization; or engineering design data.
- 33.** The method according to claim **28**, wherein said receiving step c) further comprises: delivery of at least one of software or paper deliverables related to said data from at least one of: a licensed client; a licensor; or an other client with licensed access.
- 34.** The method of claim **28**, wherein said moveable direct reading sensors of step (a) comprise at least one of: direct sensing technologies; optical sensors; chemical sensors; electromechanical sensors; membrane interface probe (MIP) sensors; advanced MIP sensors; laser induced fluorescence (LIF) sensors; ultraviolet induced fluorescence (UVF) sensors; polymer sensors; or haloprobe sensors.
- 35.** The method of claim **28**, wherein said data comprises: one or more data parameters.
- 36.** The method of claim **28**, wherein said environmental subsurface data relates to at least one of chemical or geological attributes of the subsurface.
- 37.** The method of claim **28**, further comprising: d) geo-referencing said environmental subsurface data; and
- e) using said information to select a next location for acquiring a next environmental subsurface data from said moveable direct reading sensors.
- 38.** The method of claim **37**, wherein said geo-referencing of said step (d) comprises at least one of: geo-referencing in at least two dimensions; or geo-referencing said data to a specific point on the earth's surface.
- 39.** The method of claim **38**, wherein said at least two dimensions comprise at least one of: latitude, longitude, altitude, or time.
- 40.** The method of claim **37**, wherein said geo-referencing of said step (d) comprises: geo-referencing in at least three dimensions.
- 41.** The method of claim **40**, wherein said at least three dimensions comprise at least one of: latitude, longitude, altitude, or time.
- 42.** The method of claim **28**, wherein said providing of step b) comprises at least one of: transmitting via the Internet; transmitting via a communications link; transmitting via a wired communications link; or transmitting via a wireless communications link.
- 43.** The method of claim **28**, wherein said providing of step b) comprises providing via an application server, wherein the application server comprises at least one of: an application service provider (ASP); or a software as a service.
- 44.** The method of claim **28**, wherein said analysis of said providing step b) comprises at least one of: storing said environmental subsurface data in a database; mining said environmental subsurface data; calculating said information from said environmental subsurface data using an algorithm; performing visualization processing of said environmental subsurface in at least two dimensions; displaying a graphical visualization of said data; mapping said environmental subsurface data; or displaying said environmental subsurface data in at least one of: two-dimensional (2D) or three-dimensional (3D) formats.
- 45.** The method of claim **28**, wherein said analysis of said providing step b) comprises at least one of: refining raw environmental subsurface data into processed environmental subsurface data; normalizing said environmental subsurface data for variations in acquisition of said data; normalizing for a condition of a membrane of a membrane interface probe (MIP); normalizing for variation of actual subsurface conditions including at least one of chemical concentration or soil water matrix; determining relative quality efficacy data including determining at least one of: pressure, flow rate, condition of detectors, drift, calibration, depth of probe, hydrostatic, or baseline noise of analytical/electrical system; storing said environmental subsurface data; aggregating said environmental subsurface data into aggregate environmental subsurface data; determining predictive modeling using said aggregate environmental subsurface data; assessing measure of risk using said aggregate environmental subsurface data; evaluating risk using said aggregate environmental subsurface data; calculating total mass of chemical compounds; calculating volume of affected soil and groundwater; calculating compound identification; calculating removal costs; performing sensitivity analysis; or comparing data of multiple sites.
- 46.** The method of claim **45**, wherein said step of performing a sensitivity analysis comprises at least one of: displaying using a "dashboard" type display; or providing results to at least one of an office device or a field device.

47. The method of claim 28, further comprising:  
 d) posting said information on a web site for access by authorized users.
48. The method of claim 47, wherein said web site comprises:  
 a secure Internet Web site.
49. The method of claim 28, further comprising at least one of:  
 d) transmitting said information over a network to a mobile device, or transmitting said information over a network to an office device.
50. The method of claim 49, wherein said network comprises:  
 a wireless network.
51. The method of claim 28, further comprising at least one of:  
 d) aggregating said environmental subsurface data into an aggregate database;  
 e) mining said aggregate database;  
 f) determining predictive modeling using said aggregate database;  
 g) assessing measure of risk using said aggregate database;  
 h) evaluating risk using said aggregate database;  
 i) providing the user with relative analysis of various sites based on at least one of: geological information or contaminant conditions;  
 j) grooming said environmental subsurface data;  
 k) comparing said environmental subsurface data to at least one of: historical environmental subsurface data or environmental subsurface data from other sites;  
 l) performing datamining; or  
 m) ranking sites.
52. The method of claim 28, further comprising:  
 d) transmitting said information comprising:  
 transmitting said information including completed data analytics via the Internet back to source location for decision-making and process changes; and  
 transmitting said information wirelessly to a mobile device to facilitate access via Internet protocols to said information analyzed from said sensor outputs.
53. The method of claim 28, further comprising at least one of:  
 d) normalizing said environmental subsurface data for variations in at least one of: acquisition of said environmental subsurface data, condition of membrane of a membrane interface probe (MIP), subsurface conditions including at least one of chemical concentration or soil water matrix; or  
 e) determining relative quality efficacy data including determining at least one of: pressure, flow rate, condition of detectors, drift, calibration, depth of probe, hydrostatic, or baseline noise of analytical/electrical system.
54. The method of claim 28, wherein steps a)-c) are performed by a licensed operator and wherein the first entity is a licensor and the second entity is a licensed client.
55. A method of managing the acquisition of data comprising:  
 a) receiving information, from a first entity, regarding gathered and analyzed environmental subsurface data at a first computer by a second entity,  
 wherein said environmental subsurface comprises an area beneath at least one of a surface of earth, or a surface of a body of water,  
 wherein said moveable direct reading sensors are placed in said environmental subsurface and said moveable direct reading sensors are in direct contact with at least one of soil, water, or vapor,  
 wherein said environmental subsurface data is gathered at a location by a second entity via moveable direct reading sensors, and  
 wherein the environmental subsurface data is transmitted by the second entity, via a second computer, to the first entity for analysis of said environmental subsurface data via a data analysis system to obtain information about said subsurface data.
56. The method according to claim 55, wherein said analysis comprises:  
 at least one of: a two dimensional (2D) visualization or a three dimensional (3D) visualization of geo-referenced direct reading sensor data.
57. The method according to claim 55, wherein said analysis comprises:  
 aggregating said data into a comparative database, and obtaining a relative analysis of various sites based on at least one of geological or contaminant conditions.
58. The method according to claim 55, wherein said analysis further comprises a data warehousing service comprising:  
 posting or delivering to a web site at least one of: an interactive two-dimensional visualization; an interactive three-dimensional visualization; or engineering design data.
59. The method of claim 55, wherein said data comprises:  
 one or more data parameters.
60. The method of claim 55, wherein said environmental subsurface data relates to at least one of chemical or geological attributes of the subsurface.
61. The method of claim 55, wherein said moveable direct reading sensors of step (a) comprise at least one of:  
 direct sensing technologies;  
 optical sensors;  
 chemical sensors;  
 electromechanical sensors;  
 membrane interface probe (MIP) sensors;  
 advanced MIP sensors;  
 laser induced fluorescence (LIF) sensors;  
 ultraviolet induced fluorescence (UVF) sensors;  
 polymer sensors; or  
 haloprobe sensors.
62. The method of claim 55, wherein said receiving of step a) comprises receiving via an application server, wherein the application server comprises at least one of:  
 an application service provider (ASP); or  
 a software as a service.
63. The method of claim 55, wherein said analysis comprises at least one of:  
 storing said environmental subsurface data in a database;  
 mining said environmental subsurface data;  
 calculating said information from said environmental subsurface data using an algorithm;  
 performing visualization processing of said environmental subsurface in at least two dimensions; displaying a graphical visualization of said data;  
 mapping said environmental subsurface data; or  
 displaying said environmental subsurface data in at least one of: two-dimensional (2D) or three-dimensional (3D) formats.

**64.** The method of claim **55**, wherein said analysis comprises at least one of:  
 refining raw environmental subsurface data into processed environmental subsurface data;  
 normalizing said environmental subsurface data for variations in acquisition of said data;  
 normalizing for a condition of a membrane of a membrane interface probe (MIP);  
 normalizing for variation of actual subsurface conditions including at least one of chemical concentration or soil water matrix;  
 determining relative quality efficacy data including determining at least one of: pressure, flow rate, condition of detectors, drift, calibration, depth of probe, hydrostatic, or baseline noise of analytical/electrical system;  
 storing said environmental subsurface data;  
 aggregating said environmental subsurface data into aggregate environmental subsurface data;  
 determining predictive modeling using said aggregate environmental subsurface data;  
 assessing measure of risk using said aggregate environmental subsurface data;  
 evaluating risk using said aggregate environmental subsurface data;  
 calculating total mass of chemical compounds;  
 calculating volume of affected soil and groundwater;  
 calculating compound identification;  
 calculating removal costs;  
 performing sensitivity analysis; or  
 comparing data of multiple sites.

**65.** The method of claim **64**, wherein said step of performing a sensitivity analysis comprises at least one of:  
 displaying using a “dashboard” type display; or  
 providing results to at least one of an office device or a field device.

**66.** The method of claim **55**, wherein said web site comprises:  
 a secure Internet Web site.

**67.** The method of claim **55**, wherein step a) is performed by a licensed client and wherein the first entity is a licensor and the second entity is a licensed operator.

**68.** The method according to claim **55**, further comprising:  
 b) providing said second entity with instructions based on said information.

**69.** The method according to claim **68**, wherein at least one of said receiving step a) or said providing step b) comprises:  
 receiving or transmitting said data or information via a communications link to a Web site.

**70.** The method according to claim **68**, wherein said providing step b) further comprises:  
 delivery of at least one of software or paper deliverables related to said data to at least one of: a licensor, a licensed operator; or an other client with licensed access.

**71.** The method of claim **68**, further comprising:  
 c) geo-referencing said environmental subsurface data; and  
 d) using said information to select a next location for acquiring a next environmental subsurface data from said moveable direct reading sensors.

**72.** The method of claim **71** wherein said geo-referencing of said step (c) comprises at least one of:  
 geo-referencing in at least two dimensions; or  
 geo-referencing said data to a specific point on the earth’s surface.

**73.** The method of claim **72**, wherein said at least two dimensions comprise at least one of:  
 latitude, longitude, altitude, or time.

**74.** The method of claim **71**, wherein said geo-referencing of said step (c) comprises:  
 geo-referencing in at least three dimensions.

**75.** The method of claim **74**, wherein said at least three dimensions comprise at least one of: latitude, longitude, altitude, or time.

**76.** The method of claim **68**, wherein said receiving, transmitting, and providing comprise at least one of:  
 transmitting via the Internet;  
 transmitting via a communications link;  
 transmitting via a wired communications link; or  
 transmitting via a wireless communications link.

**77.** The method of claim **68**, further comprising:  
 c) posting said information on a web site for access by authorized users.

**78.** The method of claim **68**, further comprising at least one of:  
 c) transmitting said information over a network to a mobile device, or transmitting said information over a network to an office device.

**79.** The method of claim **78**, wherein said network comprises:  
 a wireless network.

**80.** The method of claim **68**, further comprising at least one of:  
 c) aggregating said environmental subsurface data into an aggregate database;  
 d) mining said aggregate database;  
 e) determining predictive modeling using said aggregate database;  
 f) assessing measure of risk using said aggregate database;  
 g) evaluating risk using said aggregate database;  
 h) providing the user with relative analysis of various sites based on at least one of: geological information or contaminant conditions;  
 i) grooming said environmental subsurface data  
 j) comparing said environmental subsurface data to at least one of: historical environmental subsurface data or environmental subsurface data from other sites;  
 k) performing datamining; or  
 l) ranking sites.

**81.** The method of claim **68**, further comprising:  
 c) transmitting said information comprising:  
 transmitting said information including completed data analytics via the Internet back to source location for decision-making and process changes; and  
 transmitting said information wirelessly to a mobile device to facilitate access via Internet protocols to said information analyzed from said sensor outputs.

**82.** The method of claim **68**, further comprising at least one of:  
 c) normalizing said environmental subsurface data for variations in at least one of: acquisition of said environmental subsurface data, condition of membrane of a membrane interface probe (MIP), subsurface conditions including at least one of chemical concentration or soil water matrix; or  
 d) determining relative quality efficacy data including determining at least one of: pressure, flow rate, condition of detectors, drift, calibration, depth of probe, hydrostatic, or baseline noise of analytical/electrical system.

\* \* \* \* \*