

No. 851,908.

PATENTED APR. 30, 1907.

P. WALLOT & F. C. KRÜGER.

ROTARY ENGINE.

APPLICATION FILED MAY 19, 1906.

2 SHEETS—SHEET 1.

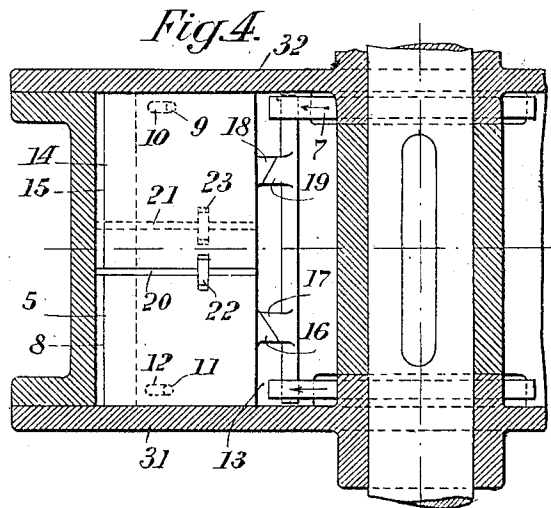
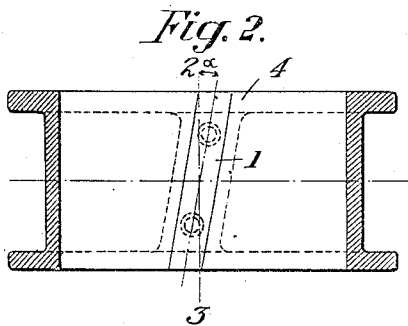
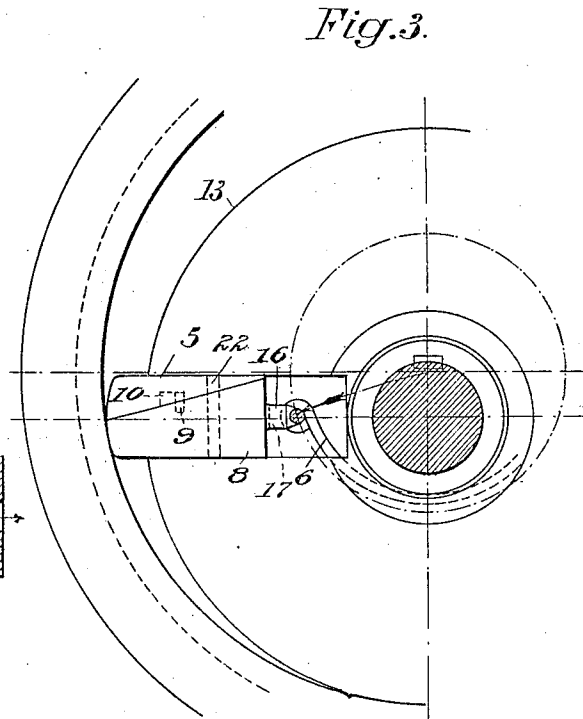
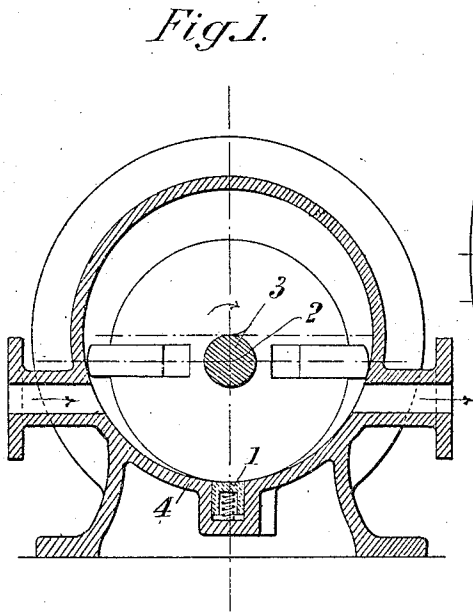

*Witnesses:*  
C. Heymann.  
L. Waldman

*Inventors*  
Paul Wallot and Friedrich Carl Krüger.  
by B. Singer *Attorney*

No. 851,908.

PATENTED APR. 30, 1907.

P. WALLOT & F. C. KRÜGER.

ROTARY ENGINE.

APPLICATION FILED MAY 19, 1906.

2 SHEETS—SHEET 2.

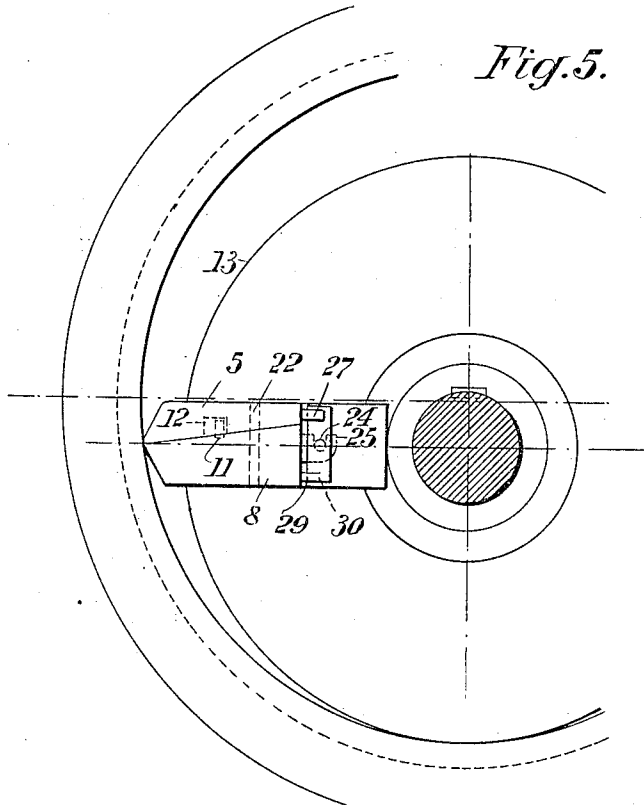

Fig. 5.

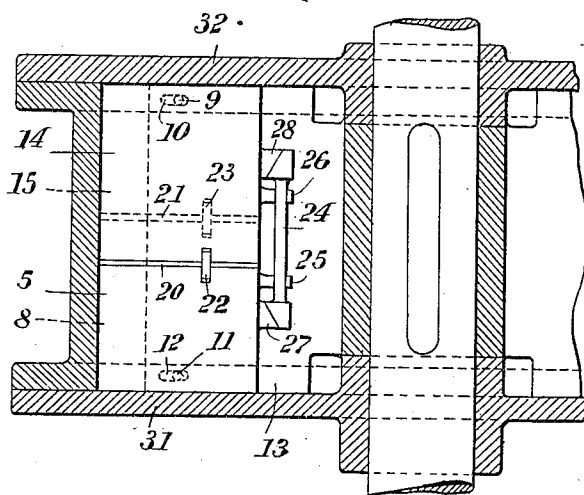

Fig. 6.

Witnesses:

L. Heymann.  
L. Waldman

Inventors

Paul Wallot and Friedrich Carl Krüger.

by B. Singer Attorney

# UNITED STATES PATENT OFFICE.

PAUL WALLOT AND FRIEDRICH CARL KRÜGER, OF HANOVER, GERMANY.

## ROTARY ENGINE.

No. 851,908.

Specification of Letters Patent.

Patented April 30, 1907.

Application filed May 19, 1906. Serial No. 317,788.

*To all whom it may concern:*

Be it known that we, PAUL WALLOT and FRIEDRICH CARL KRÜGER, both subjects of the German Emperor, and residents of Hanover, Germany, have invented certain new and useful Improvements in Rotary Engines, of which the following is a specification.

This invention has reference to rotary engines and more especially to improvements in engines or pumps with rotating sliding- or wing-pistons, and its object is to remedy defects which still exist in this well-known class of machine, which is being employed more and more for generating power, with steam, water or gas as the actuating agent, and also as an exhauster or pump for gases and liquids. In the simple form of these machines with stationary cylinder and rotating wing-piston, a broad packing strip let into the cylinder parallel to its axis and pressed by springs against the rotating piston hub is generally employed for obtaining a better steam- or gas-tight contact between said piston-hub and the cylinder on the contact line, so that, with the constant grinding there a broader contact surface results. Such arrangements have the defect that the piston wings in sliding over the packing strip receive a sudden push inward, unless the packing strip gives in the opposite direction, in which case the wings move outward owing to centrifugal action. In both cases there is an undesirable jerking or pounding action and in course of time the effectiveness of the packing strip is greatly impaired, and the first object of our invention is to minimize these defects.

In the annexed drawings: Figure 1 is a transverse section of a rotary engine showing the improved means for obtaining a steam tight joint between the drum and the casing. Fig. 2 is a horizontal section of same, the drum being removed. Figs. 3 and 4 show respectively a side elevation and plan view of the improved piston wing for rotary engines, some parts of the engine being shown in section. Figs. 5 & 6 are respectively a side elevation and a plan view of a modified form of piston wing, some parts of the engine being shown in section.

In the engine shown in Fig. 1 and 2 of the drawings, we employ the usual spring-pressed packing strip 1 but, instead of lodging it in a groove parallel to the axis of the cylinder 4, we arrange it at a certain angle  $\alpha$  to

the cylinder axis 2 3 and so that the center line of the packing strip cuts the axial contact line 2 3 midway of its length and the side edges of the strip each meet said contact line at its ends. With this arrangement, the piston wings remain in contact with the cylinder at all times, including when they are sliding over the packing strip, and the broader the cylindrical contact surfaces of the wings are so much the better is it. While one end of the wing is in contact with the packing strip and tending to press it outward, the other end is in contact with the cylinder; and consequently the centrifugal forces acting on the wings are practically entirely resisted directly by the cylinder without a break in crossing the contact line.

In course of time, owing to the constant grinding, the packing strip fits more and more closely to the piston-hub and consequently projects to some extent from its groove and is subjected to a relative extent to pounding by the piston-wings, but in our arrangement of the packing strip the blows only effect a very small part of the strip and are furthermore minimized by the crossing, and the consequent forcing down, of the strip being gradual, and the wearing action of the points of impact being in the nature of shearing and spread over a long period. A further inconvenience with rotary engines is the difficulty in maintaining the piston wings steam- or gas-tight on all sides. As is well known, the wings or vanes must not only make steam-tight contact with the cylindrical face but also with the ends of the cylinder and with the grooves in which they slide in the piston-hub. Heretofore spring-pressed packing strips, rings and the like have been employed for this purpose. All such packing means have to be mounted in suitable grooves and, strictly speaking, require packing themselves, which would lead to very complicated constructions not easily kept in order. Our invention provides a remedy for all this, in adapting the sliding piston itself to serve the purpose of all these packing devices.

In Figs. 3 & 4 of the accompanying drawings, the sliding piston or wing 5, 8 is acted upon indirectly by elastic means, shown as springs 6 and 7, to first slide the wedge-shaped part 8 of the piston, which is coupled to the part 14 by a pin-and-slot coupling 9, 10, (or 11, 12), so that said parts are pressed into steam-tight contact with the sides of the

groove in the piston-hub 13 in which they are lodged. Further, in order to obtain steam tight contact between the sides of the piston and the ends or covers of the cylinder, by the action of the same elastic means, the complete sliding piston or wing is built up of two sets of parts 5, 8 and 14, 15, fitted as just described, and each wedge 8 and 15 of the respective halves 5, 8, 14, 15 is again first indirectly so acted upon through wedge shaped bearing blocks 16, 17 and 18, 19 that each half of the piston is pressed sidewise against the relative end of the cylinder. In order to prevent steam leaking through the joints 20 and 21 when the sides of the piston begin to wear, these joints are arranged so as not to coincide and they are crossed by connecting pieces 22, 23 having a transverse telescopic action in the grooves 20 and 21 of the piston.

With a piston constructed as described, the springs 6 and 7, which are necessary in any case for obtaining a steam tight contact between the face of the cylinder and the end of the sliding piston or wing, serve to maintain all the other points of contact steam-tight. When such a piston in course of time becomes worn in its bearings in the hub, the wedges 8, 15, are pressed forward to take up the wear, steam-tight contact being thus automatically maintained there, and in like manner steam-tight contact is maintained and wear compensated for at the ends of the cylinder through wedges 17 and 19 under the action of the springs 6 and 7. A like relation exists on the contact-line of the wing with the cylinder; here also, one or the other half of the wing becomes worn at the point of contact, sometimes more and then less than the other against which it lies, owing to the moving forward of the wedge piece. This construction of sliding piston with which we have just been dealing has still a defect in that, for obtaining steam-tight contact on all sides, springs are requisite which are housed in the interior of the machine and therefore difficult to get at. Our invention comprises a further improvement, which will now be described, which is intended to obviate also this difficulty by providing suitable means for enabling the springs or the like to be replaced by steam, gas or fluid pressure behind the piston. To this end, the wedges, which in this case are acted upon by steam or fluid pressure, effect indirectly themselves their extension or tightening sidewise, by engaging, through the medium of an intermediate wedge, and pressing outward the other halves of the piston lying upon them. This improved construction of piston shown in Figs. 5 and 6 differs from that previously described, first, in the omission of all outside mechanical means of adjustment. The piston as before cuts off the working chamber completely from all other chambers, and therefore, without material loss of pressure,

any desired tension may be maintained in the latter, easily-shut-off chambers. These pressures acting upon the piston effect the making of steam-tight contact between piston and cylinder and also in the guide slot in the hub, the tension behind the pistons being necessarily maintained so that it is at least equal to the counter pressure for the time being in the working chamber. In order now to enable the pressure at the back of the sliding piston to be utilized also for extending the piston toward each end of the cylinder, the wedge-shaped piston-members 8 and 15, which as already described are connected with the other members 5 and 14, against which they lie, by means of the tangential couplings 11, 12 and 9, 10, also engage said members 5 and 14 by means of an intermediate wedge 24. Said wedge, as shown in the drawing, is mounted on the wedge-shaped parts 8 and 15 in forks 25 and 26 without other limits to sidewise movement than those presented by projections 27, 28 on the upper halves 5 and 14 of the piston, against the beveled faces of which projections the correspondingly beveled faces of the wedge abut. To prevent said wedge from twisting round it is provided with lugs 29, 30 which bear against the parts 8 and 15. This wedge 24 may if desired be reversed, *i. e.* interposed so as to bear flat upon the piston. As such a piston in course of time becomes worn away by the friction in its guide slot and, consequently, the wedge-shaped parts 8 and 15 are moved forward, the intermediate wedge 24 acts so as to press the piston members outward, *i. e.* at the same time there must be or must have been also wearing away of its two side faces; the adjusting and maintaining of the several steam-tight contacts is thus accomplished here also always automatically. The wear on the contact line between piston and cylinder is compensated for in the manner already described.

Having now fully described and ascertained the nature of our said invention and in what manner the same is to be performed, we declare that what we claim is:

1. A rotary engine comprising in combination a casing, a piston carrier, a radial piston slidably mounted therein, said piston being longitudinally divided into wedging members, and yieldingly acting means engaging one of said members to force said piston into engagement with said casing, said means also serving to maintain steam tight engagement between said members and said carrier.

2. A rotary engine comprising in combination a casing, a piston carrier, a radial piston mounted therein, said piston being horizontally divided into wedging members, a pin and slot connection for said members, and yieldingly acting means engaging one

of said members to force said piston into engagement with said casing, said means also serving to maintain engagement between said members and said carrier.

3. A rotary engine comprising in combination a casing, a piston carrier, a radial piston mounted therein, said piston being horizontally divided into wedging members, devices connecting said members, and yieldingly acting means engaging one of said members to force said piston into engagement with said casing, said means also serving to maintain engagement between said members and said carrier.

4. A rotary engine comprising in combination a casing, a piston carrier, a radial piston slidably mounted therein, said piston being horizontally divided into wedging members, yieldingly acting means engaging one of said members, and wedging devices interposed between said means and one of said members.

5. A rotary engine comprising in combination a casing, a piston carrier therefor, a piston slidably mounted in said carrier, said piston being longitudinally divided into members adapted to move laterally against the sides of the casing, and wedging devices for effecting lateral and forward movement of said members.

6. A rotary engine comprising in combination a casing, a piston carrier therefor, a piston slidably mounted in said carrier, said piston being longitudinally divided into laterally movable members, wedging devices for effecting lateral movement of said members, and yieldingly acting means for actuating said devices.

7. A rotary engine comprising in combination a casing, a piston carrier therefor, a piston slidably mounted in said carrier, said piston being longitudinally divided into laterally movable members, a steam tight connection for said members, wedging devices

effecting lateral movement of said members, and yieldingly acting means for operating said devices.

8. A rotary engine comprising in combination a casing, a piston carrier, a piston slidably mounted therein, said piston having wedging members for effecting steam tight engagement at its upper and lower walls with said carrier, and wedging devices for effecting steam tight engagement between said piston and the walls of the casing.

9. A rotary engine comprising in combination a casing, a piston carrier therefor, a piston slidably mounted in said carrier and divided horizontally in wedging members, said piston being divided longitudinally into laterally movable members, a steam tight connection for said laterally movable members, a pin and slot connection for said wedge shaped members, and wedging devices engaging one pair of said members effecting steam tight engagement between the piston and said carrier and between the piston and the walls of the casing.

10. A rotary engine comprising in combination a casing, a piston carrier, a radial piston mounted therein, said piston being horizontally divided into wedging members, a pin and slot connection for said members, and yieldingly acting means engaging one of said members to force said piston into engagement with said casing, said means serving to maintain engagement between said members and said carrier and a packing strip angularly disposed with respect to the axis of said casing.

In testimony whereof we have hereunto set our hand in presence of two witnesses.

PAUL WALLOT.  
FRIEDRICH CARL KRÜGER.

Witnesses:

PAUL SCHÉFER,  
HENRY J. FULLER.