

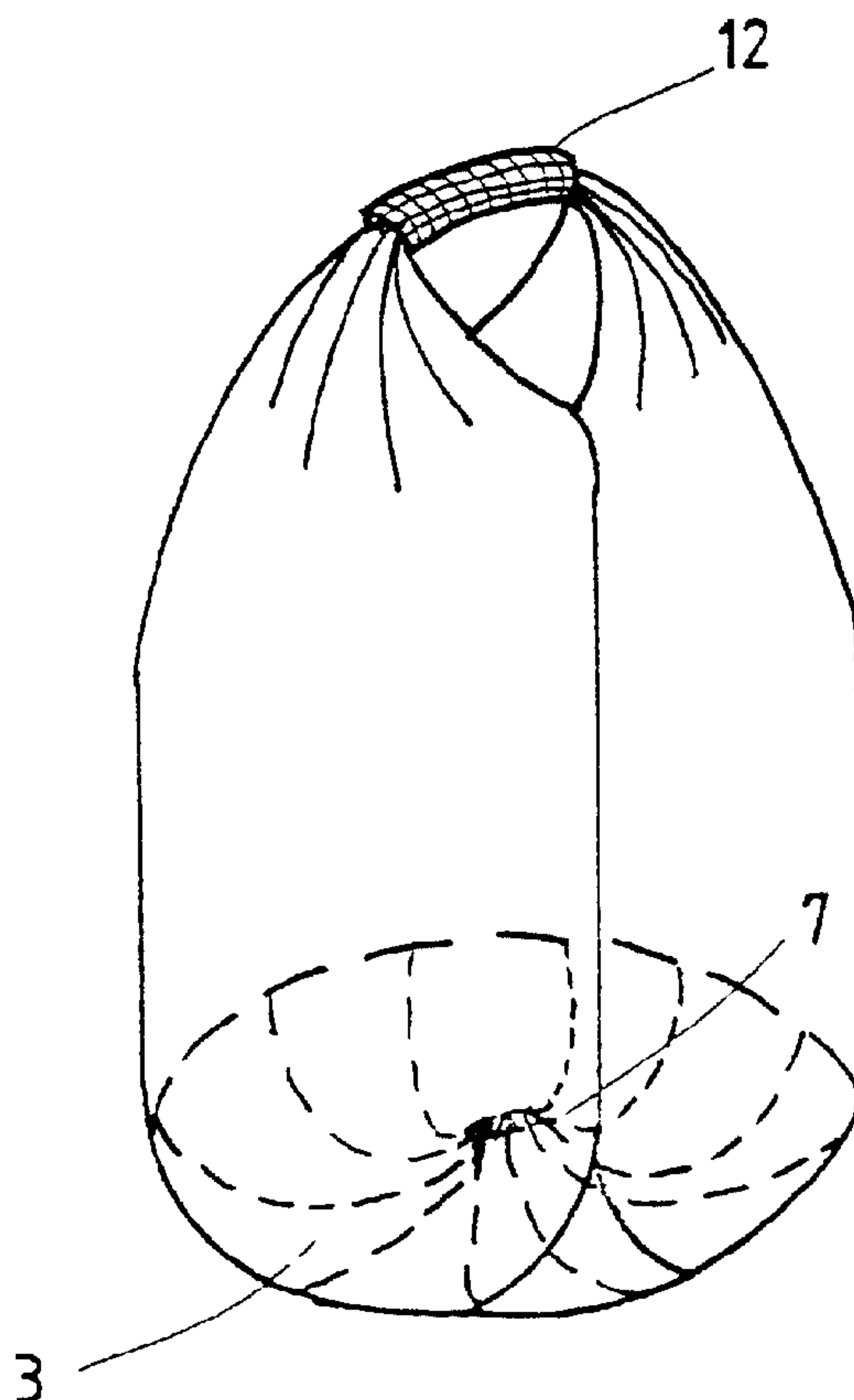

(86) Date de dépôt PCT/PCT Filing Date: 1990/02/28
 (87) Date publication PCT/PCT Publication Date: 1990/09/07
 (45) Date de délivrance/Issue Date: 2001/10/02
 (85) Entrée phase nationale/National Entry: 1991/08/27
 (86) N° demande PCT/PCT Application No.: NO 90/00039
 (87) N° publication PCT/PCT Publication No.: WO 90/09929
 (30) Priorité/Priority: 1989/02/28 (890860) NO

(51) Cl.Int.⁵/Int.Cl.⁵ B65D 33/10, B65D 33/16
 (72) Inventeurs/Inventors:
 Lysfjord, Roger, NO;
 Omdal, Bjarne, NO;
 Strand, Olaf, NO;
 Juel, Anders, NO
 (73) Propriétaire/Owner:
 Norsk Hydro a.s., NO
 (74) Agent: FETHERSTONHAUGH & CO.

(54) Titre : EMBALLAGE SOUPLE A FOND ET COUVERCLE AMELIORES
 (54) Title: A FLEXIBLE CONTAINER WITH IMPROVED BOTTOM AND TOP



(57) Abrégé/Abstract:

The present invention relates to a flexible intermediate bulk container for transportation, storage and lifting of bulk material. Said container has improved bottom and top construction, and it comprises a hose formed blank made from a round woven fabric or from at least one piece of flat woven fabric joined at its bottom and/or top end after folding the blank in three or more longitudinal folds each consisting of two layers. The length of said joint(s) being less than 1/4 of the containers circumference. The FIBC has a filling opening, a possible liner and might have lifting loops which is integral extensions of the side walls.

Abstract

The present invention relates to a flexible intermediate bulk container for transportation, storage and lifting of bulk material. Said container has improved bottom and top construction, and it comprises a hose formed blank made from a round woven fabric or from at least one piece of flat woven fabric joined at its bottom and/or top end after folding the blank in three or more longitudinal folds each consisting of two layers. The length of said joint(s) being less than 1/4 of the containers circumference. The FIBC has a filling opening, a possible liner and might have lifting loops which is integral extensions of the side walls.

A flexible container with improved bottom and top

The present invention relates to a flexible intermediate bulk container (FIBC) for lifting, transportation and storage of bulk material. Said FIBC comprise a hose formed blank of woven material joined together by seam(s) and having seam(s) across its bottom and/or top ends. The FIBC comprises also at least one lifting loop which might be integral extensions of the containers side walls, a filling opening and it might also include a liner.

The blank as defined in this application is made from round woven or flat woven material joined together for forming at least one side joint or seam. Joining said piece together can for instance be performed subsequent to the bottom and/or top joints.

FIBCs have been used for some time and have proved to be suitable for transportation, lifting and storage of bulk material like granular fertilizer, ground and unground grain, Portland cement, coal etc. in quantities of several hundred kilos per container.

Prior art reveals that the FIBCs are difficult to manufacture with a high degree of mechanization. Even relatively simple operations like the cutting of the blank, folding and sewing of side and bottom seams are done manually. If the production of the container could be mechanized the manufacture costs would be reduced due to reduction in manual labour.

Previously known FIBCs for transportation of bulk material e.g. from US patent No. 4269247 (corresponding to NO patent

No. 136744) are made from a blank of flat woven fabric, and are formed by folding the blanks at the transverse centre line and sewing the sides and the bottom. The middle section of the blank forms in the finished product a lifting loop which is an integral extension of the side walls. However, the container according to US patent No. 4269247 was made with a squarish base by making gussets at opposite sides of the hose formed blank before the base was sewn. The disadvantages of this construction are firstly that the containers are expensive to manufacture due to the long side seams and secondly that it is a difficult operation to make the gussets after the side seams have been made.

Further there is known a container according to US patent No. 4136723 (Norwegian patent No. 138134) which can be made from a round woven fabric. When it is made from a round woven fabric there will be no side seams. These containers have a double base construction comprising one or two seams each having a length of 1/4 of the containers circumference.

The inventions disclosed in said U.S. patents represents the nearest prior art to the invention, but the are not suitable for mechanized production and both of said containers have a relatively large storage volume in empty condition.

Thus the object is to make an improved FIBC where:

- the production can be fully mechanized both with and without a liner
- even stress distribution in the top and bottom part is attained
- raw material costs are reduced
- the transport and storage volume of the empty folded container are low.

To meet the above objects the inventors had to find ways to manufacture the FIBC which were suitable for mechanization. The starting point in the production of the FIBCs were to employ round woven fabric in the form of a hose formed blank. The round woven fabric versus the flat woven fabric possesses one great advantage, it does not have side seams. Side seams reduce the circumferencial strength and increase the costs of the FIBC in the manufacturing process. The present invention should therefore provide a reduction in the total seam length.

The simplest solution to the problem on how to make a FIBC with short seam length seemed to be a prefolded container which also was suitable for mechanized production. Preliminary tests indicated that the hose formed blank folded once or twice longitudinally and then joined by a transverse seam at the bottom was strong and well suited for mechanized production. In fact, the number of foldings was not restricted to only once or twice, but it might include any practical number. The preliminary tests further showed that if the seam was positioned in the centre of the bottom area of the inflated container, a container made accordingly would get a circular base. Both the positioning of the seam and the circular base will give a container with a more uniform and equal distributed stress at the lower part of the FIBC.

The method of prefolding the container was further on possible to employ when the FIBC had gusseted sides as described in CA patent No. 1221923 (Norwegian patent No. 153250).

The special features of the present invention is that the woven hose formed blank is laid flat and folded along the longitudinal axis a number of times required to make at least ~~four~~, six, eight etc. layers of fabric whereafter the bottom and/or the top is sealed. There are various ways to achieve this. One way is to make infolded pleats or gussets at opposite sides of the blank whereafter the hose formed blank is

folded at least once along the longitudinal centre axis. A joint is made transversally at the bottom and/or top line. Another method to manufacture a container with at least six layers of fabric when it is laid flat is simply to fold the hose formed blank two times longitudinally. This method will give a hose formed blank with six layers of fabric. These two methods to fold the hose formed blank is ment as examples only. There are various other ways to fold the blank longitudinally to attain at least six layers of fabric.

The total length of the bottom seam in the previously mentioned US patents are $1/2$ of the containers circumference, whereas the length of the bottom seam of the present invention is less than $1/4$ of the containers circumference.

The seam or joint at the bottom of the present invention will, when the bag is inflated, be in the center of the base. Because the stress at the centre of the base is relatively low, the seam at this point is not as critical as at the base seam in the US patent No. 4269247 which length is equal to the full width of the base area.

The manufacturing process of the present invention is simple and can be highly mechanized. The container is preferably manufactured from an "infinite" long hose formed woven material with or without gusseted sides which is cut perpendicular to the longitudinal axis at top and bottom. The container is folded at least once along the longitudinal axis, and joint by a seam at the bottom and/or the top part of the container. Cutting, folding and joining can be mechanized.

The scope of the present invention are as defined in the attached claims. The main characterizing feature is that the bottom and/or the top joints are formed subsequent to forming longitudinal folds in the blank, each consisting of two layers and that the length of said joint(s) being less than $1/4$ of the containers circumference.

28370-6

5

In its most preferred embodiment, the container comprise that the hose formed blank have longitudinal folds along the center axis and a joint across one or both ends with a length corresponding to approx. $1/8$ of the containers
5 circumference. Another embodiment comprise that the blank has three folds, each having a width corresponding to $1/6$ of the circumference of the container, and a joint across on or both ends. Further, the invention comprise fastening the liner to the bottom joint of the hose formed blank.

10 In accordance with the present invention, there is provided a flexible intermediate bulk container for the transportation and storage of bulk material, said container comprising: a hose shaped blank of woven material, said blank having a longitudinal axis, a top and a bottom; said blank
15 having formed therein at least two longitudinal folds extending parallel to said axis and defining at least three folded blank sections each including two layers of said woven material, with said at least three folded blank sections being superimposed, thus defining at least six superimposed layers of said woven
20 material; at least one of said top and said bottom of said blank having a seam extending transverse to said axis and formed by joining said at least six superimposed layers of woven material, said seam having a length in a direction transverse to said axis equal to less than one-quarter of the
25 circumference of said hose shaped blank and therefore of said container; and said top of said blank having therein a filling opening for filling bulk material into said container and having at least one lifting loop formed by at least one integral extension of the entire circumference of said blank of
30 woven material.

The invention of the container and the method for manufacturing will be described in more detail, by the way of

28370-6

5a

example only, with reference to the accompanying drawings in which:

Fig. 1 illustrates the hose formed blank with gusseted sides where;

5 a) is a front elevation view of the unfolded blank with gussets,

b) is a front elevation view of the blank (Fig. 1a) folded along the longitudinal axis with added bottom joint,

10 c) is a side view of the blank as indicated in Fig. 1b with top joint,

d-f) is Fig. 1a, b and c respectively, viewed from above.

Fig. 2 illustrates the hose formed blank in the
15 layflat position;

a) is a front elevation view of the unfolded blank,

- b) is a front elevation view of the folded blank as indicated in Fig. 2a,
- c) is a side view of the blank as indicated in Fig. 2b with an alternative top joint and added bottom joint,
- d-f) is Fig. 2a, b and c respectively, viewed from below.

Fig. 3 illustrates the hose formed blank with gusseted sides as shown in Fig. 1a.

- a) is a front elevation view of the unfolded blank with a liner positioned inbetween the gussets,
- b) is a front elevation view of the blank (Fig. 3a) folded along the longitudinal axis with top and bottom joint,
- c) is a side view of Fig. 3b including a sleeve,
- d) is Fig. 3a viewed from above.
- e) is an enlarged end view taken along the line 1-1 of Fig. 3b.

Fig. 4 illustrates the inflated flexible container with integral lifting loops and bottom part, both according to the invention.

Fig. 1a illustrates an unfolded piece of a hose formed blank material with an open top 1 and bottom 2. The hose formed blank has a front panel 3, a back panel 4 and gusseted sides 5,6. The hose formed blank can either be manufactured from a

flat woven fabric including one or more side seams, or it can be manufactured from a round woven fabric. If the hose formed blank is made from a flat woven fabric, it might be transversally folded at its centre line which will form the bottom or the lifting loop of the finished manufactured container.

The container has a transverse joint which forms the seam 7 which constitutes the bottom of the container. The diameter and length of the hose formed blank and the width of the gusseted sides should be defined depending on what volume is needed.

The blank is formed by cutting the required length of an "infinite" length of a base material, and the cutting operation is perpendicular to the longitudinal axis 8 of the blank. Fig. 1b illustrates the hose formed blank when it is doubled by folding the material at its longitudinal center axis 8. The end view of Fig. 1b is shown in Fig. 1e.

As one can see from the end view of Fig. 1e, the material section now comprises a total number of eight layers of woven fabric, and the width of the material section shown in Fig. 1a has been halved. It is of course possible to double the hose formed blank shown in Fig 1b even one or several times more if desired. The bottom joint 7 is made transversally to the longitudinal axis 8 and relatively close to the bottom opening 2. Fig. 1c illustrates by example only a lifting loop 13 made by overlapping the two integral extensions of the side wall. The lifting loop 13 construction is not restricted to that shown, but may as well comprise a joint similar to the bottom joint.

Fig. 2 illustrates a second method to obtain at least six layers of fabric by folding the hose formed blank longitudinally. Fig. 2b shows an example where the hose formed blank has been folded twice. The first fold is done a distance corresponding to $1/6$ of the circumference along line 9, whereas

the second folding is along line 10. The lifting loop 14 illustrated in Fig. 2c is made according to the applicants U.S. patent No. 4925317. The bottom seam 7 will have a length equal to $1/6$ of the circumference of the hose formed blank shown in Fig. 2a.

Fig. 3 illustrates the hose formed blank as shown in Fig. 1a, but with a liner 15 positioned inside the hose formed blank. Fig. 3b shows a folded hose formed blank with two joints, one at the bottom line 7 and one at the top line 11. The liner 15 can be fastened to the bottom joint. By cutting at least two longitudinal slots close to the top end of the hose formed blank, one will make an opening for the lifting means. If the blank is made of a flat woven fabric, the corresponding opening for the lifting means is done by sewing the side seam close to, but not up to the top part of the blank. The lifting loop can comprise a sleeve 12 as described in the applicant's ^{EP} ~~NO~~ patent ^{specification} application No. ~~830718~~ ⁰¹¹⁸¹¹².

Fig. 4 illustrates that the bottom of the flexible container will be rosette shaped. The seam will, when the flexible container is inflated and made according to the example illustrated in Fig. 1, point vertically into the center axis of the container bottom 3. This has two great advantages, firstly that the bottom 3 is very strong because of even stress distribution and secondly that the seam is not exposed to frictional wear and tear during transportation of the container. A FIBC made according to the invention will therefore also be safer. The stress is uniformly and equally distributed from the walls to the bottom without any stress distribution peaks due to the circular shape of the bottom. The seam in the bottom is actually located at the point of lowest stress. The FIBC shown in Fig. 4 comprises also a sleeve 12.

Tests were carried out to compare the tension strength of flexible containers according to US patent No. 4269247, US patent No. 4136723 and the present invention. The present

invention was manufactured according to Fig. 1 and comprised a sleeve 12.

The containers were filled with approximately 500 kg of free flowing material and the test rig used is as described in NO patent No. 152870.

The containers were first stretched five times to a load twice the weight of the container and then stretched to rupture. The load at rupture and the place of rupture are stated in table 1.

All test containers are made of the same polypropylene fabric having a dimension of 1250 mm x 2000 mm (plane width x length). The results are shown in table 1.

The containers used in test 1 are made according to US patent No. 4269247, which is made from a flat woven fabric, folded transversally at its centre axis and having seams in the wall and base structure. It comprise integral lifting loops where all the vertical fibres in the wall structure are engaged to carry the load. This container design has a lifting loop with the highest rupture load possible without increasing the fabric strength.

The containers used in test 2 are a slightly modified version of the containers used in test 1. The top and sides are made according to US patent No. 4269247 whereas the bottom is made according to the invention as illustrated in Fig. 1a and b. They are formed from a flat-woven fabric folded transversally at its centre line having side and bottom seams. The side walls are gusseted whereafter the hose formed blank is folded along the longitudinal axis and joined by a seam at the bottom line 7. By comprising the container in test 1 with the container used in test 2 one will get an indication on what effect the bottom design according to the invention has upon the load carrying capacity of the container.

The containers used in test 3 are made according to US patent No. 4136723 which represents the nearest prior art, and it is in the preferred example made from a round woven hose formed blank with a double base construction comprising two seams each having a length of 1/4 of the containers circumference. The lifting loop is formed by joining the integral extension of the side walls with a single seam.

The containers used in test 4 are made according to the present invention as seen in Fig. 1 and Fig 4. The lifting loop comprises a sleeve and is made by overlapping the two integral extensions of the side walls before sewing. Previous tests have indicated that the strength of this lifting loops is as strong as the lifting loop described in test 1.

Table 1.

Container load No.	Container construction	Container rupt.	Place of	Rupt. (KN)
1.1	Acc. to NO pat. No. 136744	Bottom	32	
1.2	Acc. to NO pat. No. 136744	Bottom	32	
2.1	Acc. to NO pat. No. 136744 Modified	Bottom	37	
2.2	Acc. to NO pat. No. 136744 Modified	Top fabric	38	
3.1	Acc. to NO pat. No. 138134	Lifting loop	30.5	
3.2	Acc. to NO pat. No. 138134	Lifting loop	31	
4.1	Acc. to the present invention	Top fabric	36	
4.2	Acc. to the present invention	Top fabric		38

The tests gave the following results:

Tests 1.1 - 1.2 had a rupture load of 32 kN and rupture place was at the bottom whereas the modified container in test 2.1 - 2.2 had a mean value of the rupture load of 37,5 kN. Test 2 has a rupture load approx. 20% above test 1. Test 2 also shows that the bottom construction has a rupture load equal to the maximum load carrying capacity of the container, as one container ruptured at the top and one at the bottom.

Tests 3.1 - 3.2 had a rupture load of 31 kN whereas the mean value of the rupture load of test 4.1 - 4.2 was 37. The rupture load of test 4 is also approx. 20% above the rupture load of test 3. Test 4 shows that it is impossible to increase the load carrying capacity further without increasing the strength of the fabric itself. This is obvious because the place of rupture is not in the lifting loop or in the bottom part, but in the wall fabric close to the lifting loop.

The test results indicate clearly that the container according to the invention gives increased load carrying capacity compared to those of US patent No. 4269247 and US patent No. 4136723. With a bottom construction according to the present invention one has arrived at a bottom construction which has a load carrying capacity approx. 20% above the containers according to said US patents.

The simple method of cutting, joining the bottom and folding the hose formed blanks used in the test shows also that the manufacture of the container according to the present invention can be highly mechanized.

A further effect of the present invention is that the empty container has a low volume in storage and transport compared to previously known containers. The low volume is an effect of the folding.

The inventors have by the present invention arrived at a container construction which can be manufactured with a high degree of mechanization and at the same time increasing their load carrying capacity. These objects are achieved by making a container which has a design where the cutting operation is simple, the sewing operation has been minimized and the folding is suitable for mechanization.

All the aforementioned manufacturing steps for the flexible container according to said invention, i.e. cutting of the blank, making the gussets, prefolding the hose formed blank and sewing can be achieved by use of relatively simple, fast operating and cheap manufacturing equipment.

28370-6

14

CLAIMS:

1. A flexible intermediate bulk container for the transportation and storage of bulk material, said container comprising:

5 a hose shaped blank of woven material, said blank having a longitudinal axis, a top and a bottom;

said blank having formed therein at least two longitudinal folds extending parallel to said axis and defining at least three folded blank sections each including two layers
10 of said woven material, with said at least three folded blank sections being superimposed, thus defining at least six superimposed layers of said woven material;

at least one of said top and said bottom of said blank having a seam extending transverse to said axis and
15 formed by joining said at least six superimposed layers of woven material, said seam having a length in a direction transverse to said axis equal to less than one-quarter of the circumference of said hose shaped blank and therefore of said container; and said top of said blank having therein a filling
20 opening for filling bulk material into said container and having at least one lifting loop formed by at least one integral extension of the entire circumference of said blank of woven material.

2. A container as claimed in claim 1, wherein said top
25 of said blank has a respective said seam.

3. A container as claimed in claim 2, wherein said bottom of said blank has a respective said seam.

4. A container as claimed in claim 1, wherein said bottom of said blank has a respective said seam.

28370-6

15

5. A container as claimed in claim 1, wherein said longitudinal folds include inwardly folded gussets formed in opposite side portions of said blank and an additional fold around said axis, thereby defining a total of eight
5 superimposed layers of woven material, and wherein said length of said seam is equal to one-eighth of said circumference of said blank.

6. A container as claimed in claim 1, wherein said blank has formed therein two said folds, thereby defining three said
10 folded sections each having a width in a direction transverse to said axis equal to one-sixth of said circumference of said blank.

7. A container as claimed in claim 1, wherein said seam is formed at said bottom of said blank, and further comprising
15 a line positioned within said blank and having a bottom end fastened in said seam.

8. A container as claimed in claim 1, having an internal capacity sufficient to contain several hundred kilos of bulk material.

FETHERSTONHAUGH & CO.

OTTAWA, CANADA

PATENT AGENTS

Fig.1a

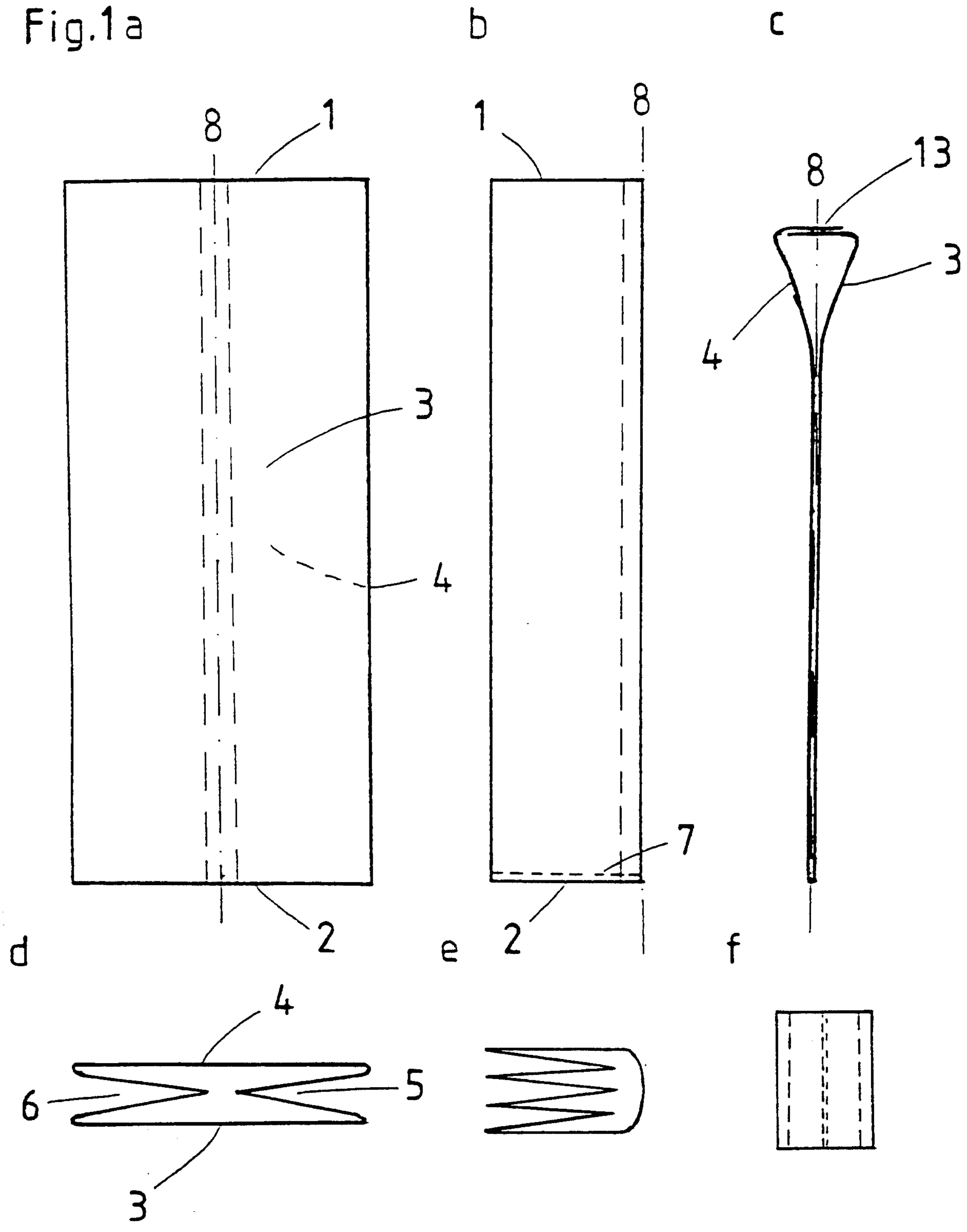

Fig. 2

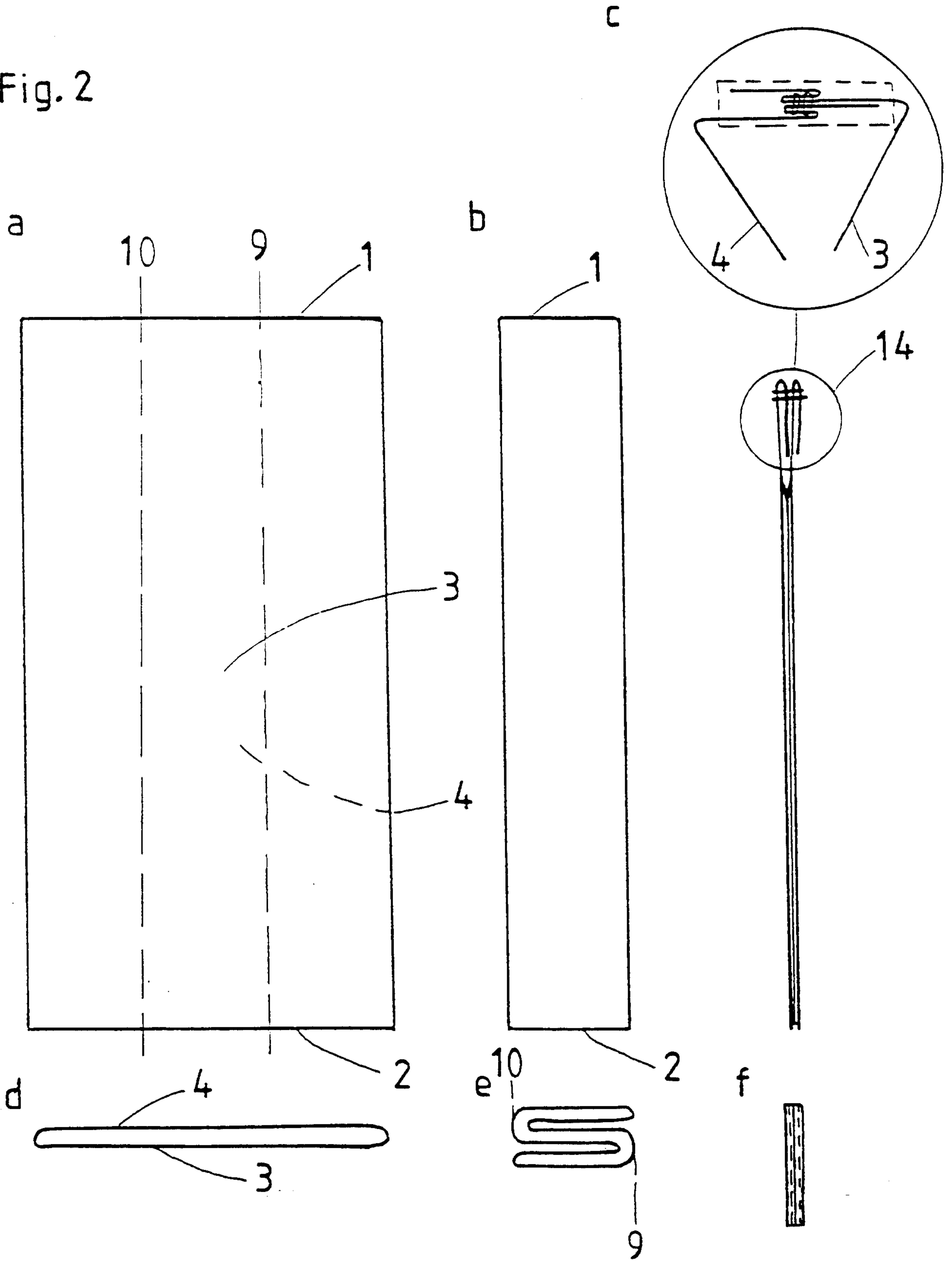
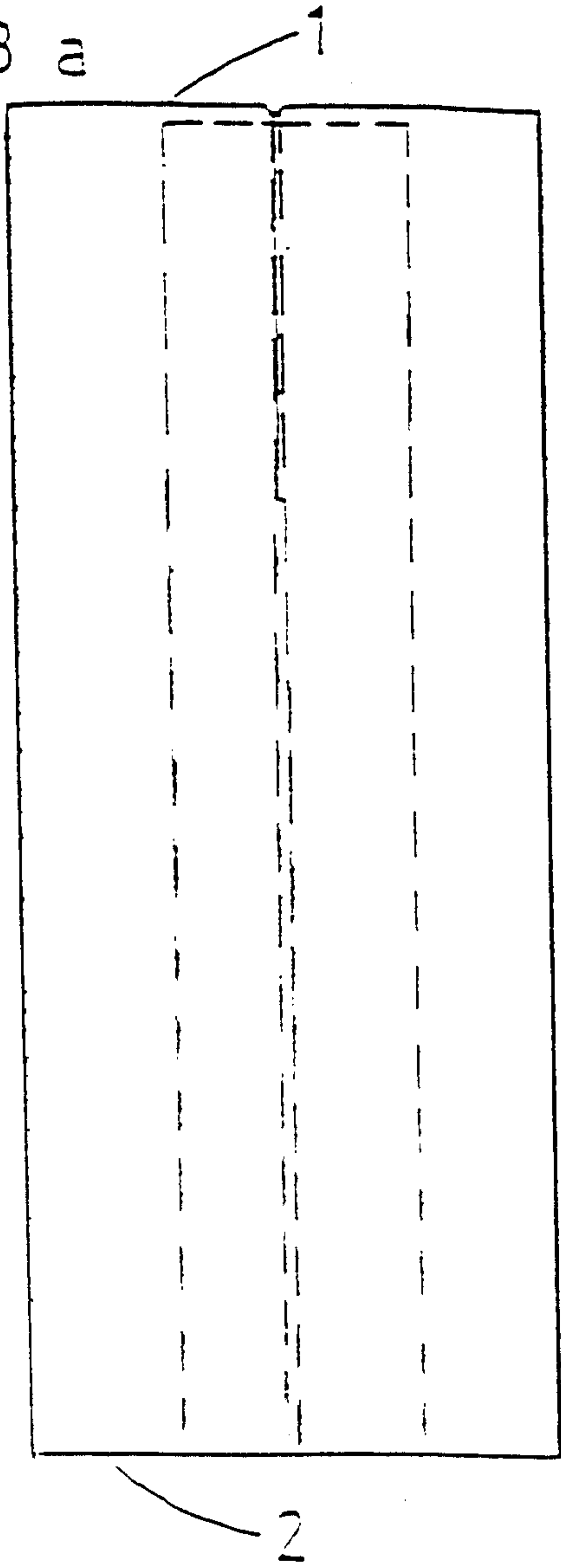
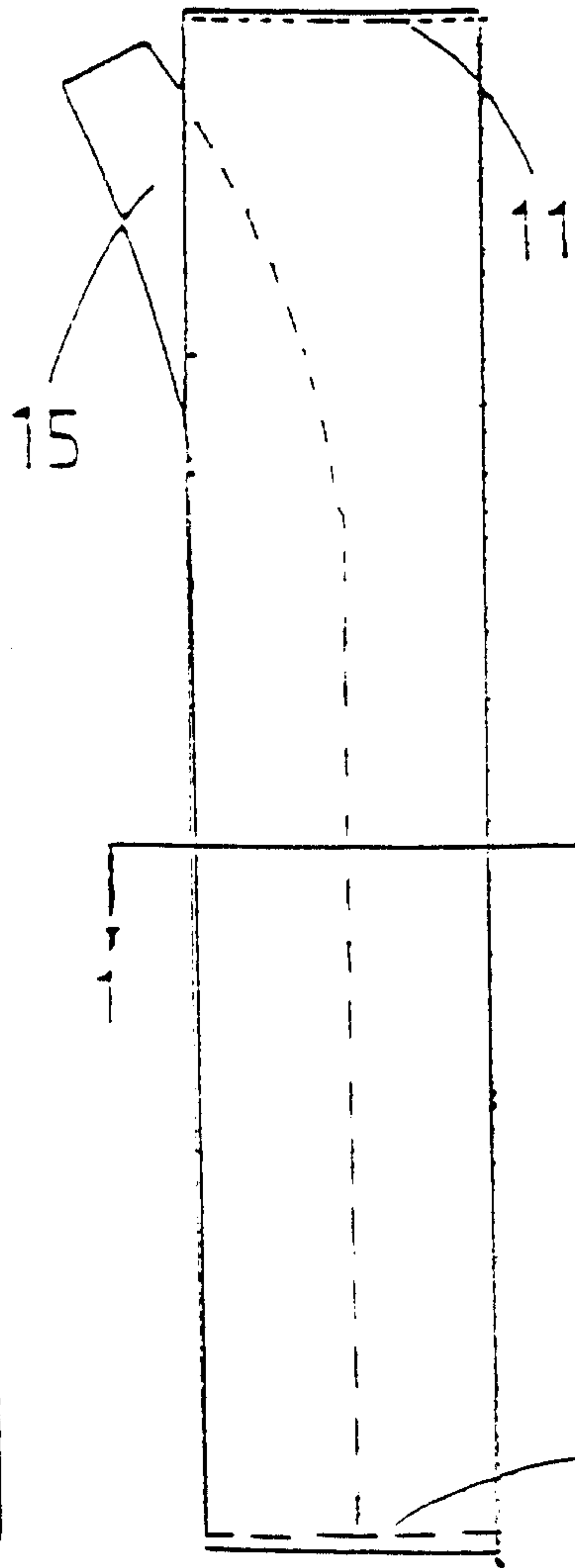

Fig. 3 a



b



c

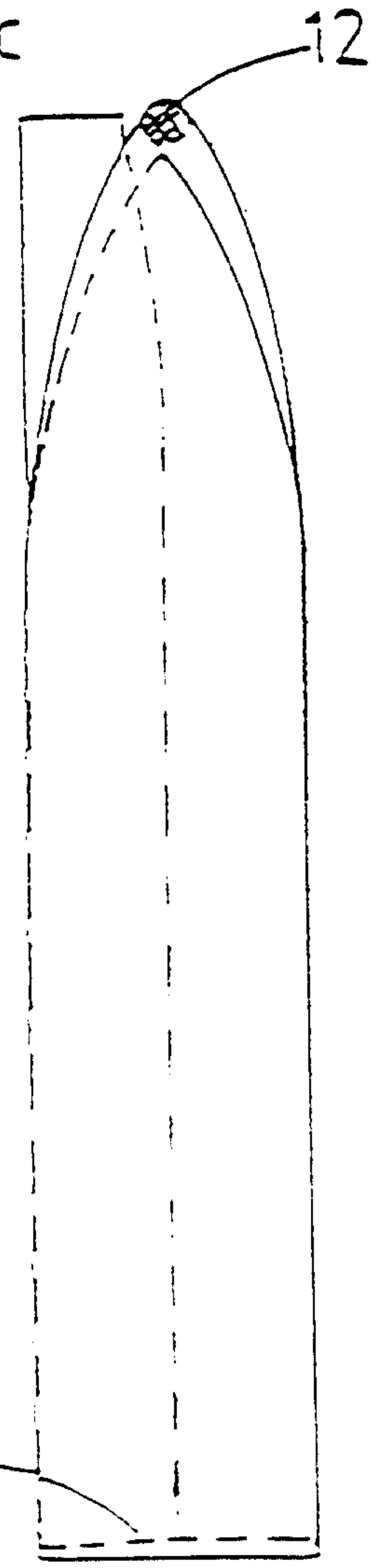

d

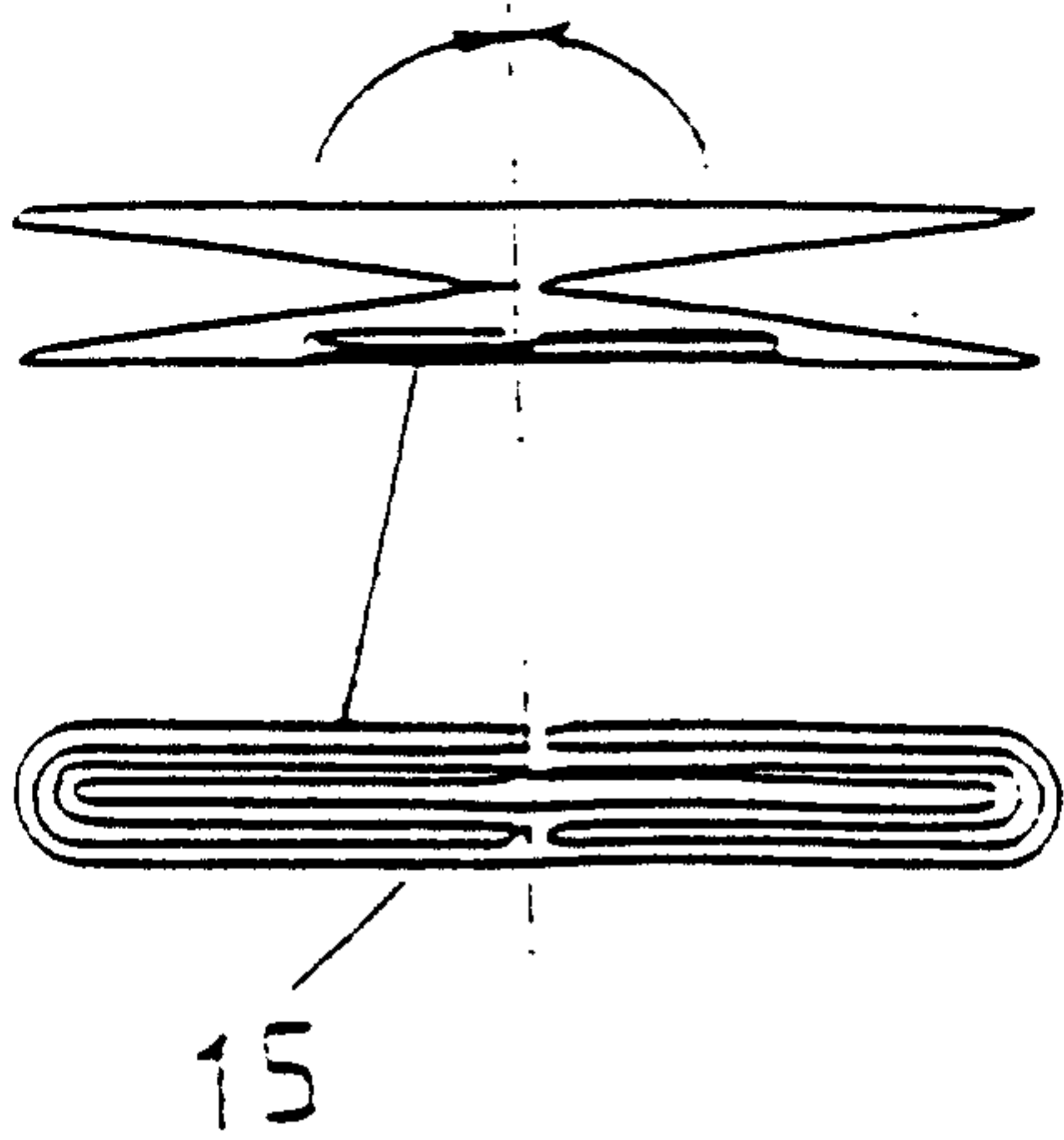

e

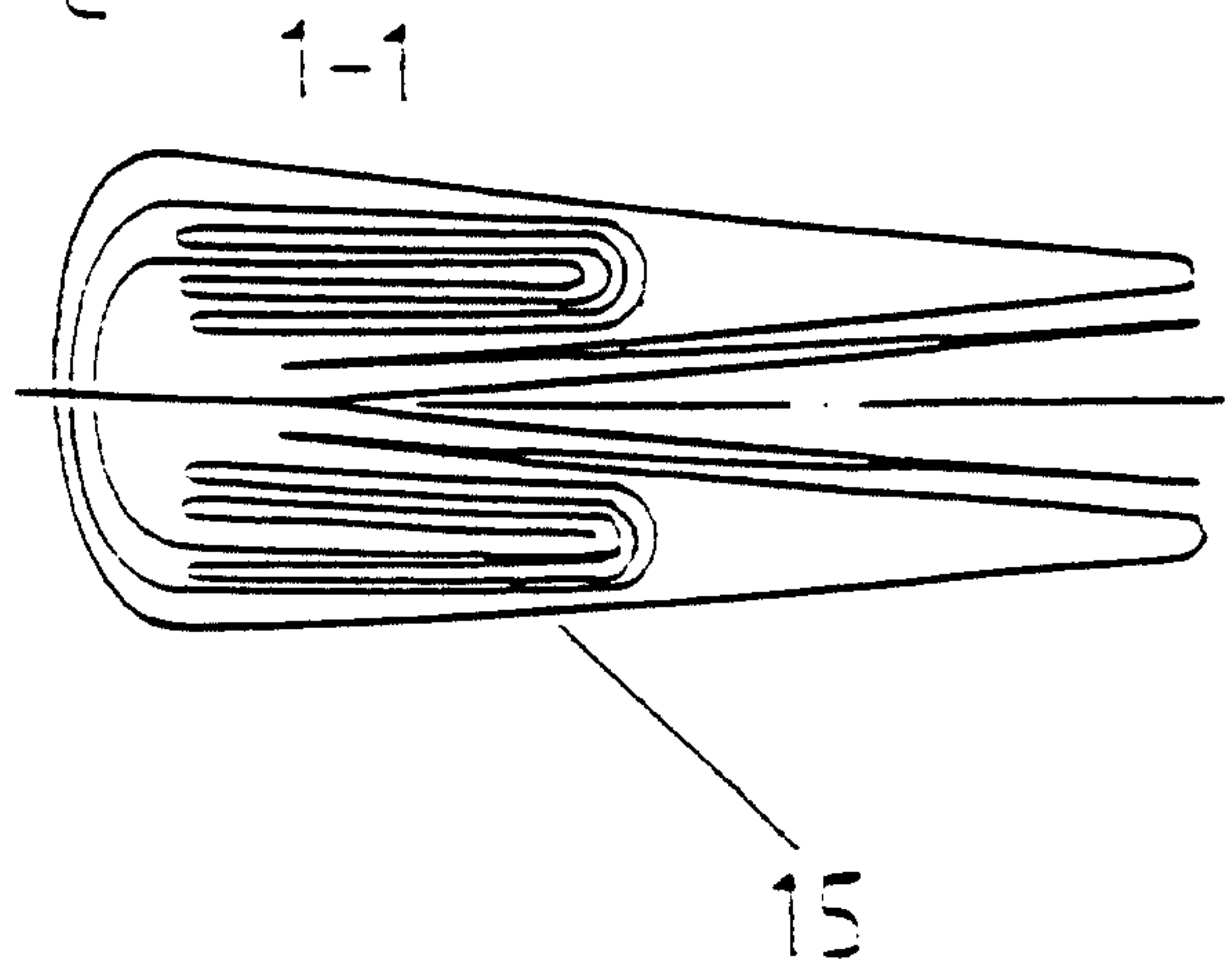
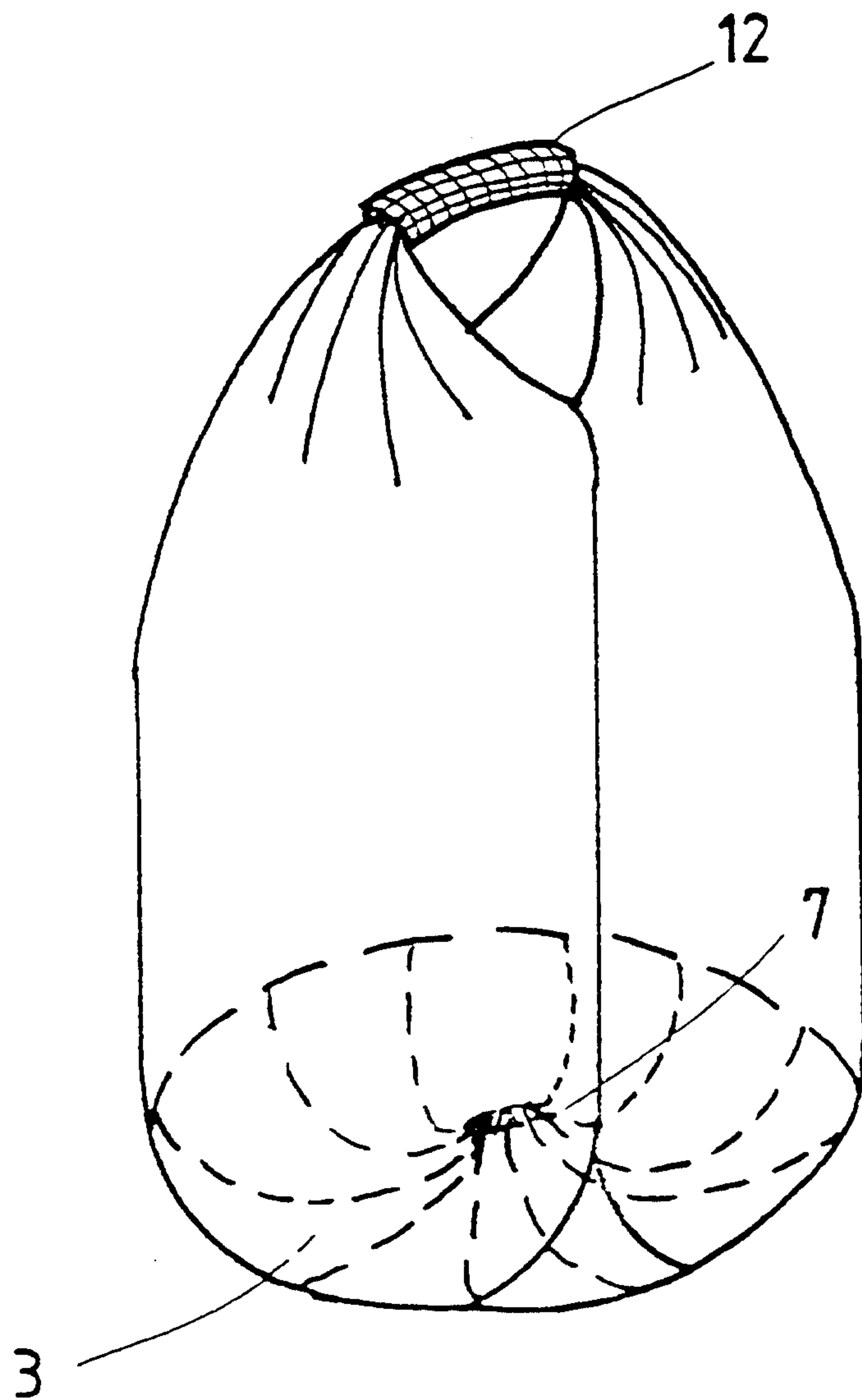
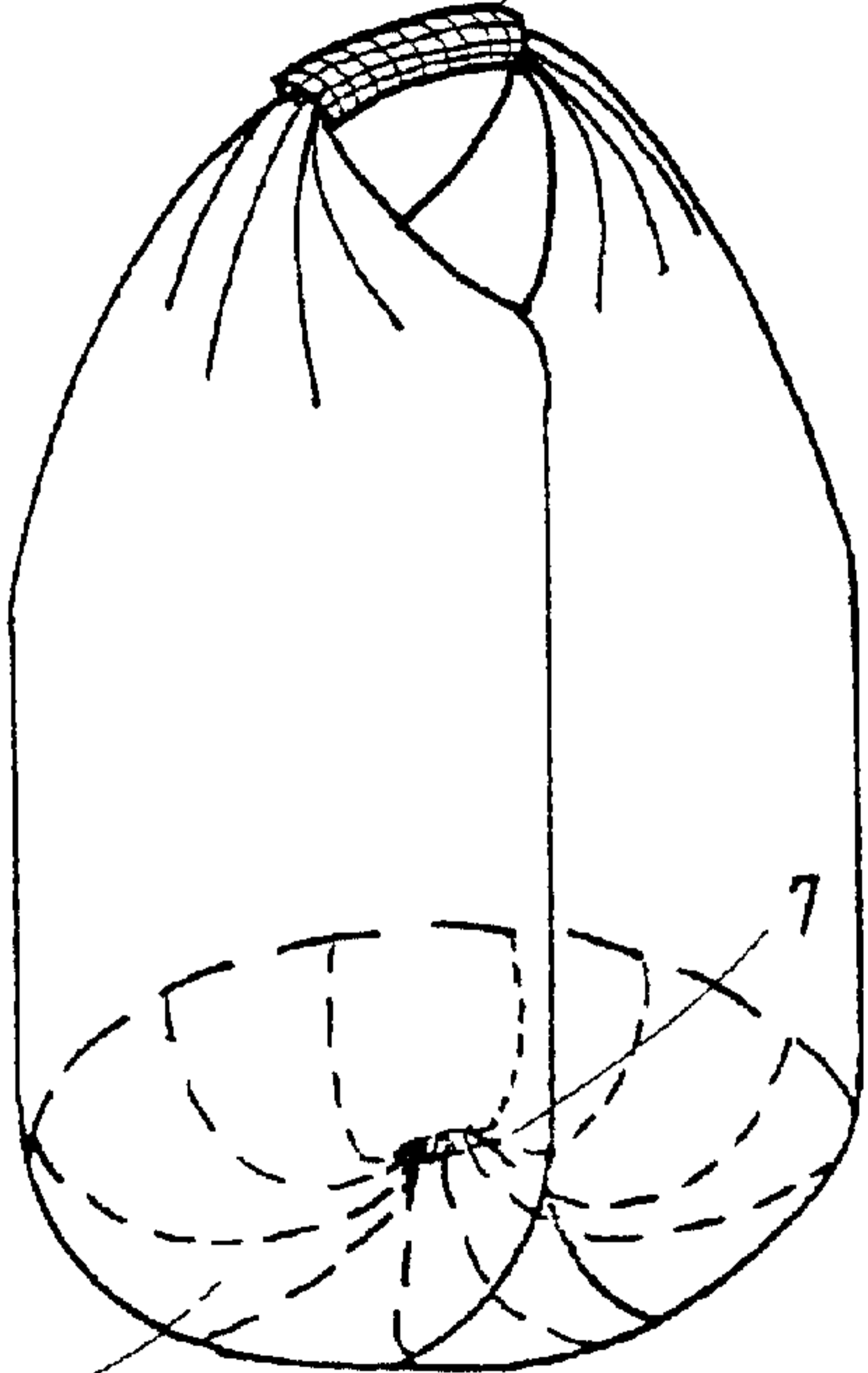

Fig. 4



12



3