



- (51) International Patent Classification:
A24F 47/00 (2006.01)
- (21) International Application Number:
PCT/GB2015/050574
- (22) International Filing Date:
27 February 2015 (27.02.2015)
- (25) Filing Language: English
- (26) Publication Language: English
- (30) Priority Data:

1403566.1	28 February 2014 (28.02.2014)	GB
1408173.1	8 May 2014 (08.05.2014)	GB
1413018.1	23 July 2014 (23.07.2014)	GB
1413019.9	23 July 2014 (23.07.2014)	GB
1413028.0	23 July 2014 (23.07.2014)	GB
1413030.6	23 July 2014 (23.07.2014)	GB
1413032.2	23 July 2014 (23.07.2014)	GB
1413034.8	23 July 2014 (23.07.2014)	GB

3LJ (GB). **MURISON, Ian**; c/o Beyond Twenty Ltd, 107 Maltings Place, 169 Tower Bridge Road, London SE1 3LJ (GB). **MARSH, Stephen**; c/o Beyond Twenty Ltd, 107 Maltings Place, 169 Tower Bridge Road, London SE1 3LJ (GB).

(74) Agent: **ORIGIN LIMITED**; Twisden Works, Twisden Road, London NW5 1DN (GB).

(81) Designated States (unless otherwise indicated, for every kind of national protection available): AE, AG, AL, AM, AO, AT, AU, AZ, BA, BB, BG, BH, BN, BR, BW, BY, BZ, CA, CH, CL, CN, CO, CR, CU, CZ, DE, DK, DM, DO, DZ, EC, EE, EG, ES, FI, GB, GD, GE, GH, GM, GT, HN, HR, HU, ID, IL, IN, IR, IS, JP, KE, KG, KN, KP, KR, KZ, LA, LC, LK, LR, LS, LU, LY, MA, MD, ME, MG, MK, MN, MW, MX, MY, MZ, NA, NG, NI, NO, NZ, OM, PA, PE, PG, PH, PL, PT, QA, RO, RS, RU, RW, SA, SC, SD, SE, SG, SK, SL, SM, ST, SV, SY, TH, TJ, TM, TN, TR, TT, TZ, UA, UG, US, UZ, VC, VN, ZA, ZM, ZW.

- (71) Applicant: **BEYOND TWENTY LTD** [GB/GB]; 107 Maltings Place, 169 Tower Bridge Road, London SE1 3LJ (GB).
- (72) Inventors: **MEMARI, Kevah**; c/o Beyond Twenty Ltd, 107 Maltings Place, 169 Tower Bridge Road, London SE1 3LJ (GB). **BENNETT, Adrian**; c/o Beyond Twenty Ltd, 107 Maltings Place, 169 Tower Bridge Road, London SE1

(84) Designated States (unless otherwise indicated, for every kind of regional protection available): ARIPO (BW, GH, GM, KE, LR, LS, MW, MZ, NA, RW, SD, SL, ST, SZ, TZ, UG, ZM, ZW), Eurasian (AM, AZ, BY, KG, KZ, RU, TJ, TM), European (AL, AT, BE, BG, CH, CY, CZ, DE, DK, EE, ES, FI, FR, GB, GR, HR, HU, IE, IS, IT, LT, LU, LV, MC, MK, MT, NL, NO, PL, PT, RO, RS, SE, SI, SK,

[Continued on next page]

(54) Title: E-CIGARETTE PERSONAL VAPORIZER

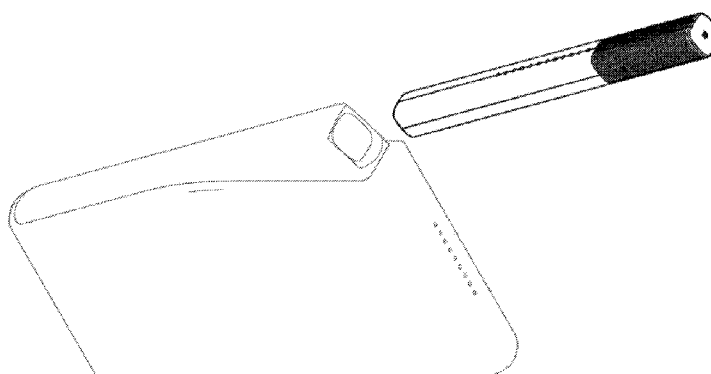

FIGURE 4

(57) Abstract: A re-fillable and re-chargeable e-cigarette PV that is not disassembled in normal use for re-filling or replenishing with e-liquid and is also not disassembled in normal use for battery access or replacement or other battery interaction.



SM, TR), OAPI (BF, BJ, CF, CG, CI, CM, GA, GN, GQ, GW, KM, ML, MR, NE, SN, TD, TG). **Published:**

— with international search report (Art. 21(3))

E-CIGARETTE PERSONAL VAPORIZER

BACKGROUND OF THE INVENTION

1. Field of the Invention

The field of the invention relates to an electronic cigarette personal vapouriser, also known as an electronic cigarette (e-cig or e-cigarette), vapestick, modding kit, personal vaporizer (PV), advanced personal vaporizer (APVs) or electronic nicotine delivery system (ENDS). In this specification, we will typically use 'PV' or 'e-cigarette' as the generic term. A PV vapourises 'e-liquid' or vaping substance to produce a non-pressurised vapour or mist for inhalation for pleasure or stress-relief, replicating or replacing the experience of smoking a cigarette. An 'E-liquid' or vaping substance is a liquid (or gel or other state) from which vapour or mist for inhalation can be generated and whose primary purpose is to deliver nicotine.

PVs are therefore mass-market consumer products that are equivalent to cigarettes, and are typically used by smokers as part of a cigarette reduction or cessation program. The main ingredients of e-liquids are usually a mix of propylene glycol and glycerine and a variable concentration of tobacco-derived nicotine. E-liquids can include various flavourings and also come with varying strengths of nicotine; users on a nicotine reduction or cessation program can hence choose decreasing concentrations of nicotine, including at the limit zero concentration nicotine e-liquid. The term 'e-liquid' will be used in this specification as the generic term for any kind of vaping substance.

E-cigarette PVs were first conceived in 1963 and for the last 50 years of development have generally been seen as a separate and distinct category compared with conventional medicinal delivery systems. To emphasise the difference over medicinal devices, we will also in this specification use the term 'e-cigarette PV', as opposed to the term 'PV'.

Despite this sector being over 50 years old, there are still many practical problems that have not yet been solved and that are a barrier to e-cigarette PVs achieving mass-market

success; they are still a long way from replacing conventional cigarettes. If they were to largely replace cigarettes, then some experts state that large-scale adoption could bring significant public health benefits. Writing in the British Journal of General Practice, DOI: 10.3399/bjgp14X681253, published 1 September 2014, Prof Robert West and Dr Jamie Brown from University College London stated that “For every million smokers who switched to an e-cigarette we could expect a reduction of more than 6000 premature deaths in the UK each year, even in the event that e-cigarette use carries a significant risk of fatal diseases, and users were to continue to use them indefinitely.”

2. Technical Background

PVs are typically battery-powered devices which simulate tobacco smoking by producing inhalable vapour (typically propylene glycol and nicotine). They generally use a heating element known as an atomizer, that vaporizes a liquid solution known as e-liquid or ‘juice’. E-liquids usually contain a mixture of propylene glycol, vegetable glycerin, nicotine, and flavorings, while others release a flavored vapor without nicotine. Vaporization is an alternative to burning (smoking) that avoids the inhalation of many irritating toxic and carcinogenic by-products. Apart from simulating tobacco smoking, the electronic vapouriser can also be used as a smoking-cessation aid or for nicotine (or other substance) dosage control.

Most electronic cigarettes take an overall cylindrical shape although a wide array of shapes can be found: box, pipe styles etc. First generation electronic cigarettes were usually designed to simulate cigarettes in their use and appearance. They are often called ‘cig-a-likes’. Cig-a-likes are usually disposable, low cost items and the user-experience is often quite poor. New generation electronic cigarettes, often called mods, modding-kits or APV's (advanced personal vaporizer) have an increased nicotine-dispersal performance, housing higher capacity batteries and come in various form factors, including metal tubes and boxes. Many electronic cigarettes are composed of standardized replaceable parts that are interchangeable from one brand to the other, while disposable devices combine all components into a single part that is discarded when its liquid is depleted. Common components include a liquid delivery and container system like a cartridge or a tank, an atomizer, and a power source.

Atomizer

An atomizer generally consist of a small heating element responsible for vaporizing e-liquid, as well as a wicking material that draws liquid in. Along with a battery, the atomizer is the central component of every personal vaporizer. Differences between atomizers cause differences in the ingredients and their concentrations delivered to users, even when the same liquid is used.

A small length of resistance wire is coiled around the wicking material and then connected to the positive and negative poles of the device. When activated the resistance wire (or coil) quickly heats up, thus turning the liquid into a vapor, which is then inhaled by the user.

Wicking materials vary greatly from one atomizer to another but silica fibers are the most commonly used in manufactured atomizers. A wide array of atomizers and e-liquid container combinations are available.

Cartomizers

A cartomizer (a portmanteau of cartridge and atomizer) or 'carto' consists of an atomizer surrounded by a liquid-soaked poly-foam that acts as an e-liquid holder. It is usually disposed of once the e-liquid acquires a burnt taste, which is usually due to an activation when the coil is dry or when the cartomizer gets consistently flooded (gurgling) because of sedimentation of the wick. Most cartomizers are refillable even if not advertised as such.

Cartomizers can be used on their own or in conjunction with a tank that allows more e-liquid capacity. In this case the portmanteau word of "carto-tank" has been coined. When used in a tank, the cartomizer is inserted in a plastic, glass or metal tube and holes or slots have to be punched on the sides of the cartomizer to allow liquid to reach the coil.

Clearomizers

Clearomizers or "clearos", not unlike cartotanks, use a clear tank in which an atomizer is inserted. Unlike cartotanks, however, no poly-foam material can be found in them. There are a lot of different wicking systems employed inside of clearomizers to ensure

good moistening of the wick without flooding the coil. Some rely on gravity to bring the e-liquid to the wick and coil assembly (bottom coil clearomizers for example) whereas others rely on capillary action and to some degree the user agitating the e-liquid while handling the clearomizer (top coil clearomizers)

Power

Most portable devices contain a rechargeable battery, which tends to be the largest component of an electronic cigarette. The battery may contain an electronic airflow sensor whereby activation is triggered simply by drawing breath through the device, while other models employ a power button that must be held during operation. An LED to indicate activation may also be employed. Some manufacturers also offer a cigarette pack-shaped portable charging and re-filling case (PCC), which contains a larger battery capable of charging e-cigarettes. Devices aimed at more experienced users may sport additional features, such as variable power output and support of a wide range of internal batteries and atomizer configurations and tend to stray away from the cigarette form factor. Some cheaper recent devices use an electret microphone with a custom IC to detect airflow and indicate battery status on the included blue LED.

Variable power and voltage devices

Variable voltage or power personal vaporizers are devices that contain a built in electronic chip that allows the user to adjust the power that goes through the heating element. They usually incorporate a LED screen to display various information. Variable PV's eliminate the need of having to replace an atomizer with another one of lower or higher electrical resistance to change the intensity of the vapour (the lower the resistance, the higher the vapour intensity). They also feature voltage regulation and some battery protection.

Some of these devices offer additional features through their menu system such as: atomizer resistance checker, remaining battery voltage, puff counter, activation cut-off etc.

E-liquid

E-liquid, e-juice or simply "juice", refers to a liquid solution that produces a mist or vapour when heated by an atomizer. The main ingredients of e-liquids are usually a mix of propylene glycol (PG), vegetable glycerin (VG), and/or polyethylene glycol 400 (PEG400), sometimes with differing levels of alcohol mixed with concentrated or extracted flavorings; and a variable concentration of tobacco-derived nicotine. There is variability in the purity, kinds and concentrations of chemicals used in liquids, and significant variability between labeled content and concentration and actual content and concentration

E-liquid is often sold in bottles or pre-filled disposable cartridges, or as a kit for consumers to make their own. Components are also available individually and consumers may choose to modify or boost their flavor, nicotine strength, or concentration with various offerings. Pre-made e-liquids are manufactured with various tobacco, fruit, and other flavors, as well as variable nicotine concentrations (including nicotine-free versions). The standard notation "mg/ml" is often used in labeling for denoting nicotine concentration, and is sometimes shortened to a simple "mg".

Source acknowledgement for this Technical Background section: Wikipedia entry on e-cigarettes.

3. Discussion of Related Art

The patent literature in this field is quite extensive, with the earliest e-cigarette PV dating from 1963.

Some of the more relevant patent disclosures in this space include the following. We highlight some of the main reasons why each item of prior art lacks relevance.

US 2014/020697 Liu.

- Just a PV charging device
- No e-liquid re-filling capability
- No user-replaceable e-liquid cartridge

- No data processor with communications capability

CN 202679020 Chen:

- Just a PV charging device
- No e-liquid re-filling capability
- No user-replaceable e-liquid cartridge
- No data processor with communications capability

US 2013/342157 Liu

- Just a PV charging device
- No e-liquid re-filling capability
- No user-replaceable e-liquid cartridge
- No data processor with communications capability

CN 201630238 Jian

- Just a PV charging device
- No e-liquid re-filling capability
- No user-replaceable e-liquid cartridge
- No data processor with communications capability

WO 2011/095781 Kind

- Not e-liquid, e-cigarette related
- No e-liquid re-filling capability— fills a pressurised gas instead
- No user-replaceable e-liquid cartridge (the gas canister is not described as being user-replaceable and doing so would in fact require the user to take the entire unit to pieces, so it teaches away from user-replaceability)
- No electrical charging capability (device has no battery)
- No data processor with communications capability

US 2012/167906 Gysland

- Not a PV charging device
- Just an e-liquid filling device, using a standard e-liquid squeezable bottle; the user unscrews the PV, separating it into an atomiser portion and an e-liquid chamber

portion, and then screws the e-liquid chamber portion into one end of this device and screws the squeezable bottle into the other end of this device and then squeezes the bottle to transfer the e-liquid over.

- No charging capability
- No data processor with communications capability

WO 2011/026846 Wedegree

- Not e-liquid PV related– instead, it's a propane powered heat-based device
- No e-liquid re-filling, just re-fills a device with liquid propane
- Mouthpiece is removed before the device is inserted for gas re-filling
- No charging capability
- No user-replaceable cartridge
- No data processor with communications capability

WO 2009/001078 Kind

- Not e-liquid, e-cigarette related
- No e-liquid re-filling– fills pressurised gas instead
- No user-replaceable cartridge (gas canister in the refill unit is itself re-filled)
- No charging capability
- No data processor with communications capability

For completeness, we mention also another item of non-analogous art, which is firmly in the medical inhalation field and lacks any specific reference to e-cigarettes or nicotine delivery. The field of this invention is rather different from medical inhalation devices, such as asthma inhalers or other metered dose inhalers, since cigarette smoking is very clearly not a medicinal activity. Specifically, the mind-set of the e-cigarette designer is to replicate as closely as possible the non-medicinal cigarette smoking experience, but without combusting tobacco. Metered dose inhalers on the other hand are typically designed for accurate, rapid, and very occasional (e.g. emergency-only) oral delivery of one or two doses of pressurised medicinal aerosol; the user experience of a PV is quite different, with relatively slow, but frequently repeated inhalations of a mist or vapour from a non-pressurised source; the experience is designed to be similar to, and hence an effective replacement for, the experience of smoking a conventional tobacco cigarette.

One example of a metered dose inhaler is shown in US 6637430 Ponwell. This lacks relevance for the following reasons:

- No explicit relevance to e-cigarettes – primarily, this is a piezo-electric metered dose inhaler system for respiratory medicines – a very different field from e-cigarette PVs
- Not suitable for re-filling PVs since it uses a needle in the case to puncture a rubber septum in the metered dose inhaler (a conventional approach used in the medicinal context where maintaining sterility of the medicament is key). But this rubber septum would degrade and tear with more than a few re-insertions; this is not an issue for a metered dose inhaler which is used relatively infrequently and sterility of the medicament is more important than durability of the medicament transfer mechanism.
- No user-replaceable liquid cartridge (in fact, teaches re-filling the medicament container, so it is not a user-replaceable cartridge)
- Is not a combined carrying and storage case for the metered dose inhaler

Emphasising the distance between the field of metered dose inhalers and e-cigarette PV design, one of the many problems facing the designer of an e-cigarette PV is how to minimise any toxins in the vapour produced by the PV.

For example, in the paper in the New England Journal of Medicine, ‘Hidden Formaldehyde in E-Cigarette Aerosols’ N Engl J Med 2015; 372:392-394, the authors describe how they tested for the presence of formaldehyde-releasing agents (whose safety when inhaled is not fully understood) in the vapour of an e-cigarette PV with a variable voltage power source: ‘At low voltage (3.3 V), we did not detect the formation of any formaldehyde-releasing agents (estimated limit of detection, approximately 0.1 µg per 10 puffs). At high voltage (5.0 V), a mean (\pm SE) of 380 ± 90 µg per sample (10 puffs) of formaldehyde was detected as formaldehyde-releasing agents.’ They go on to state ‘How formaldehyde-releasing agents behave in the respiratory tract is unknown, but formaldehyde is an International Agency for Research on Cancer group 1 carcinogen.’ One solution would appear to be to ensure that e-cigarette PVs run at low voltage (e.g. 3.3V) and not higher voltages, like 5V. But the problem that then arises is that the PV current has to be higher for a good ‘vaping’ experience, and that in turn means that (a) the PV battery runs down more quickly, and (b) the e-liquid is consumed more rapidly.

This is inconvenient with conventional designs of PV because recharging or replacing a battery takes time and because re-filling with e-liquid takes time; users would for example then need to carry around spare batteries or charging cables and e-liquid bottles. This is very different from the relatively straightforward and simple experience (and, to smokers, deeply attractive ritual) of opening a pack of conventional cigarettes and just lighting up. Because we see replicating the behavioural aspects of the cigarette smoking user experience as key to a successful product, these are major drawbacks for conventional PV designs.

One solution is to use a large 'modding-kit' type PV with a very large capacity battery that can run at the low 3.3V voltage associated with no formaldehyde release and a large e-liquid reservoir. These devices can be the size of several packets of cigarettes, and so the user sacrifices easy portability. But the performance or user experience can be good, since these devices can produce good quantities of vapour, without the need for frequent and inconvenient battery re-charging or replacement and e-liquid re-filling. When e-liquid does need to be replenished however, that is typically done by dis-assembling the unit to expose the reservoir and to then squeeze e-liquid into the reservoir from a small bottle; this can be slow and cumbersome; users often then carry around a replacement bottle or e-liquid, especially if they are using e-cigarettes to quit tobacco smoking, since if they were to run out of e-liquid, then the temptation to buy a packet of cigarettes to smoke could prove hard to resist. And this complex e-liquid re-filling process clearly has none of the simplicity or attractive ritual of opening a packet of cigarettes and lighting up.

An ideal solution would be an e-cigarette PV with the form factor of a conventional cigarette, and with the best aspects of the performance and user experience of a large modding kit type PV. This specification describes such a solution. The solution is designed to replicate many of the key behavioural and experiential aspects that make smoking attractive to smokers (e.g. the tactile satisfaction of holding a cigarette packet and opening the lid and withdrawing a cigarette; the action of holding a slim cigarette; the simplicity of the user's only action being to light up). Replicating these user experience aspects is we believe key to the successful mass-market adoption of e-cigarettes and hence delivering on their considerable public health potential.

SUMMARY OF THE INVENTION

The invention is a re-fillable and re-chargeable e-cigarette PV that is not disassembled in normal use for re-filling or replenishing with e-liquid and is also not disassembled in normal use for battery access or replacement or other battery interaction.

BRIEF DESCRIPTION OF THE FIGURES

Examples of the invention will now be described with reference to the accompanying diagrams, in which:

FIGURE 1 is a schematic view of a prior art e-cigarette, showing how the device can be dis-assembled into three pieces.

All of the remaining figures depict elements of an e-cigarette PV or PV case that solve problems with the prior art.

FIGURE 2 is an isometric view of an e-cigarette PV;

FIGURE 3 and **4** show that e-cigarette partly withdrawn from its portable, personal storage and carrying case;

FIGURE 5 shows a user-replaceable e-liquid cartridge adapted to be inserted into or attached to a portable, personal storage and carrying case for a PV;

FIGURE 6A is view of a simplified version of the case showing the user replaceable e-liquid cartridge and the battery withdrawn from the portable re-filling and re-charging and re-filling case and Figure 6B shows the case with the PV holder hinged downwards, ready to accept a PV;

FIGURE 7 is a cross sectional view of the portable case of Figure 6, together with an e-cigarette PV;

FIGURE 8 shows the PV being inserted into the portable case of Figure 6 for re-filling with e-liquid;

FIGURE 9 is a detailed view of the e-liquid-filling mechanism in the portable case of Figure 6;

FIGURE 10 is a cross sectional view of the PV when stored in the portable case of Figure 6;

FIGURE 11 is a cross-sectional view of the PV of Figure 6;

FIGURE 12 is an example of a portable case with side-loading of the PV;

FIGURE 13 is an example of a portable case with top-loading of the PV;

FIGURE 14 is a cross-sectional view of the PV as it re-fills with e-liquid when pushed down onto the re-fill mechanism;

FIGURES 15 – 19 are deliberately omitted

FIGURE 20 shows an isometric view of a working prototype of the case, with the PV holder or chassis shown closed;

FIGURE 21 shows an isometric view of the working prototype of the case, with the PV holder or chassis shown opened, and the PV fully inserted into the holder;

FIGURE 22 shows an isometric view of the working prototype of the case, with the PV holder or chassis shown opened, and the PV raised upwards, ready for withdrawal by the user;

FIGURE 23 are isometric views of the holder or chassis;

FIGURE 24 is an isometric view of the PV used in the working prototype;

FIGURE 25 is a cross-section view of the PV;

FIGURE 26 is a cross-section view of the case, with chassis closed and no PV present;

FIGURE 27 is a cross-section view of the case, with chassis open and no PV present;

FIGURE 28 is a cross-section view of the case, with chassis closed and PV present; the inter-lock is not engaged with the sliding contact block;

FIGURE 29 is a cross-section view of the case, with chassis closed and PV present; the inter-lock is engaged with the sliding contact block;

FIGURE 30 is a cross-section view of the case, with chassis open and PV present; the inter-lock is engaged with the sliding contact block and the PV is being heated;

FIGURE 31 is a cross-section view of the case, with chassis open and PV present; the inter-lock is no longer engaged with the sliding contact block and the PV is shown popped up from the chassis, ready for the user to extract;

FIGURE 32 - 35 is a close up of the sliding contact block assembly and PV in each of the four Figures 28 – 31;

FIGURE 36 is an exploded view of the sliding contact block assembly;

FIGURE 37A is a side view of the sliding contact block assembly;

FIGURE 37B is a top view of the sliding contact block assembly;

FIGURE 38 is an exploded view of the key components, including PV, chassis, cartridge, and the sides of the case;

FIGURE 39 is deliberately omitted

FIGURE 40 is a close up showing the PV resting against the pump in the case; chassis is open;

FIGURE 41 is a close up showing the PV pushed down against the pump; chassis is open;

FIGURE 42 is a close up showing the PV pushed down against the pump; chassis is closed;

FIGURES 43 - 49 are deliberately omitted;

FIGURES 50 – 53 show the pump at its various positions;

FIGURE 54 is deliberately omitted

FIGURES 55 - 59 shows the user-replaceable e-liquid cartridge, with integrated pump and overflow valve, in its various positions;

FIGURE 60 is an exploded isometric view of the PV;

FIGURE 61 is an isometric view of the PV;

FIGURE 62 is a close-up view of the wick and coil assembly; the coil runs perpendicular across the long axis of the PV;

FIGURE 63 is a close-up view of a different design of wick and coil assembly; the coil runs parallel to the long axis of the PV;

FIGURE 65 is an exploded view of the ring connector that provides power and data contacts on the PV

FIGURE 66 is a cross-sectional view of the ring connector;

FIGURE 67 – 69 show the variable air intakes of the PV;

FIGURE 70 is a high-level schematic showing a portable re-filling case able to communicate wirelessly and also through a wired connection to a smartphone, a laptop and a modem;

FIGURE 71 shows schematically that the portable re-filling unit includes electronics componentry, such as a memory, wireless/wired connectivity, software, and a controller/processor; there are four e-liquid cartridges, each with a different flavor and/or strength of nicotine.

FIGURE 72 shows how the user's smartphone can display the current levels of e-liquid in each separate cartridge;

FIGURE 73 shows a PV being withdrawn from its case; this automatically initiates heating of the e-liquid using the battery in the PV. A 'ready' light on the PV illuminates when the device is ready to use.

FIGURE 74 shows an example of a PV including an indication of how much substance has been vapourised;

FIGURE 75 shows a conventional two-part PV, with an e-liquid cartridge above the atomizer and the atomiser above the battery, plus a third module in the middle that indicates the amount of e-liquid consumed;

FIGURE 76 shows a time-locked case for a PV;

FIGURE 77 shows a humidity sensor for a PV;

FIGURE 78 and 79 are deliberately omitted

FIGURES 80-84 show various approaches to eliminating or reducing leakage of e-liquid from the PV;

FIGURE 85 shows a PV with a hygienic mouthpiece;

FIGURE 86 shows a PV with a hygienic mouthpiece and that uses a single-dose e-liquid capsule at the end of the PV furthest from the mouthpiece;

FIGURE 87 shows a PV and a dispenser for single-dose e-liquid capsules;

FIGURE 88 is deliberately omitted

FIGURE 89 – 94 show cross-sectional views of a PV with various atomization improvements;

Key to numerals in the Figures

- 1 Personal Vaporiser - PV
- 2 PV holder and receptacle chassis
- 3 Reservoir (a user-replaceable e-liquid cartridge)
- 4 Pump
- 5 4 Way Sliding Contact Block
- 6 Case - L/h
- 7 Case - R/h
- 8 Cam Block
- 9 Guide Plate
- 10 Pawl/Lever
- 11 Solenoid Mounting Block
- 12 Chassis Lid
- 13 Valve Mounting Cup
- 14 Valve Mounting Cap
- 15 Reservoir Gasket
- 16 PCB - Main Case
- 17 Leaf Spring
- 18 Pivot Screw
- 19 Spring - Pawl/Lever

20	Split Spring Pin - Pawl Spring
21	Split Spring Pin - Pawl Pivot
22	Solenoid
23	Spring - 4 Way Sliding Contact Block
24	Contact Finger
25	Ring Contact
26	Insulating Ring
27	Seal Inlet - PV
28	O Ring - PV Chamber
29	Valve - PV Tip
30	Spring - PV Tip Valve
31	Grub Screw - PV Tip
32	PV Tip
33	Screw - Guide Plate
34	Valve - Pump
35	Screw - Leaf Spring
36	End Cap - Ring Connector
37	PCB Mounting Cap / Ring Connector
38	Pin - 180° - Ring Connector
39	Pin - 135° - Ring Connector
40	Pin - 45° - Ring Connector
41	Pin - 0° - Ring Connector
42	Ring Contact
43	Insulation Ring
44	Screw - Ring Connector
45	Support Ring - 4 Way Sliding Connector
46	Body - 4 Way Sliding Connector
47	Wires - 4 Way Connector Block
48	Fluid Chamber - PV
49	Ring Connector Assembly
50	Vaporiser End Cap
51	Vaporiser Insulating Sleeve
52	Coil and Wick Assembly
53	Vaporiser Outer Body

54	Bush - Vaporiser Body
55	Vaporiser Inner Body
56	Tube Body - Vaporiser
57	Pressure Sensor Housing
58	Pressure Sensor / Transducer
59	Battery - PV
60	PV PCB
61	Hollow Stem Shaft
62	Moulded Rim/Undercut
63	Moulded Lip Seal
64	RGB LED Indicator
65	Reset Switch
66	Arduino Chip
67	Micro USB Connector
68	Battery - Chassis
69	PCB Standoffs
70	Microswitch
71	Power Connection Insulating Bush
80	Fluid chamber inside the pump
81	Fluid inlet end
82	Fluid outlet end
83	Slotted tube for ball
84	Feed-through hole
85	Piston
86	Piston rod
87	Bias spring
88	Valve stem
89	Piston return spring
90	Valve cap
91	Tapered valve seat
92	Ball valve
93	Return spring
94	Valve seal washer
95	Reservoir cap

- 96 Spring guide
- 97 Reservoir body
- 98 longitudinal heating coil
- 99 heating coil chassis
- 100 Re-filling and re-charging case

DETAILED DESCRIPTION

Figure 1 shows a conventional personal vapouriser ('PV'). The PV includes the following key components: a 'juice' or 'e-liquid' delivery and container system, called a cartridge (A), and an atomizer (B) for vapourising the juice, and a power source (C) to power the atomiser. The cartridge also forms the mouthpiece. A typical design, as shown in **Figure 1**, requires the battery (C) to be screwed into the atomiser (B), and the cartridge (A) is then pushed onto the free end of the atomiser B. When the cartridge is fully consumed, the user discards the used cartridge and replaces it with a new one. An alternative design sees the cartridge as user-refillable, typically from a small bottle of e-liquid.

Conventional PV designs suffer a number of drawbacks. This Detailed Description section describes a number of high-level features which address the most significant drawbacks. An implementation of this invention uses one or more of these high level features.

We will organise our description of the features using the following categories:

Section A. E-Liquid Re-filling and Re-Charging Storing and Carrying Case

- | | |
|------------|--|
| Feature 1. | Combined re-charge and re-fill storage and carrying case |
| Feature 2. | Case with movable PV holder |
| Feature 3. | Re-Filling the PV |
| Feature 4. | PV Locking mechanism |
| Feature 5. | Data connectivity |
| Feature 6. | E-fulfilment |

Section B. PV: Simplicity and ease of use

- | | |
|------------|----------------------------------|
| Feature 7. | Re-fillable and re-chargeable PV |
| Feature 8. | PV with pre-heat |

- Feature 9. PV with dosage indication
Feature 10. PV with drip prevention

Section C. User-replaceable e-liquid cartridge

- Feature 11. User-replaceable e-liquid cartridge that fits into the portable storage and carrying case

Section D Miscellaneous

- Feature 12 Hygienic PV
Feature 13 Single capsule dispenser
Feature 14 Single capsule PV
Feature 15 Various constructional improvements

Note that each high-level feature listed above, and the related, detailed features listed below for each high-level feature, can be combined with any other high-level feature and any other detailed feature. **Appendix 1** provides a consolidated summary of each of these.

Introduction

The following sections will describe an e-cigarette system that implements aspects of the invention; this system includes:

- an e-cigarette PV; the size and shape can be similar to, or slightly larger than, a conventional cigarette. This is shown in **Figure 2**. Mimicking the size and shape of a conventional cigarette is very helpful since it makes the PV much more attractive to smokers trying to quit cigarettes.
- a portable, personal storage and carrying case that both re-charges the battery in the PV and also re-fills the e-liquid chamber in the PV; the size and shape can be similar to, or slightly larger than, a conventional cigarette packet of 20 cigarettes. This is shown in **Figure 3** (PV partly withdrawn from its case) and **Figure 4** (PV fully withdrawn from its case)
- a user-replaceable cartridge that is slotted into the case and can be readily

swapped out by the user for a fresh cartridge when running low or to try different strengths or flavours of e-liquid. The cartridge capacity can be approximately 10ml of e-liquid; this might approximate very roughly to five packets of 20 cigarettes. See **Figure 5**.

Because the PV can be stored in the case whenever it is not being used, and the case may operate to re-fill the PV from its user-replaceable cartridge and also re-charge the PV, the PV can always be in its fully re-filled and re-charged state whenever it is removed from the case. There is no longer any need for the user to carry around spare batteries for the PV or small re-fill bottles of e-liquid.

One design of this new system, as shown in **Figures 3** and **4**, has the PV being automatically replenished with e-liquid when it is slotted into a holder that hinges outwards from the main body of the case and the user manually pushes the PV up and down, activating a micro-pump that transfers e-liquid from the user-replaceable cartridge in the case to a reservoir in the PV. When the holder is closed into the case, the electrical contacts on the PV engage with charging contacts inside the case, transferring power from the case battery to the rechargeable battery in the PV. This means:

- Vaping performance of the PV is always optimal; there is none of the performance degradation associated with a weak PV battery or a nearly empty PV e-liquid reservoir.
- The PV can vape at the lower voltages (possibly associated with zero formaldehyde emissions – see Discussion of Related Art above): in a conventional system this can provide a good vaping experience when the resistance of the heating wire in the atomizer is sufficiently low (and hence the overall power is sufficient but not too high, typically in the 6 – 8 watts band), but leads to the serious disadvantages of high battery drain and high e-liquid consumption. These disadvantages are now rendered wholly irrelevant with the new system because of the ease of both re-filling and re-charging the PV using the storage and carrying case.
- Because the storage case is designed to be a portable, personal storage and carrying case (typically similar in size to a pack of 20 cigarettes), the user will generally always carry it with him or her (in their pocket or handbag etc) and hence always store the PV away in it. Because the storage case is considerably

larger than a conventional PV, it can store far more e-liquid in its user-replaceable e-liquid cartridge and can include a much larger capacity battery. Hence, the e-liquid cartridge in the carrying case only needs to be replaced relatively infrequently (for a typical 20 cigarette a day smoker switching to this system, then a new cartridge might be needed every five days: very roughly, 10 inhalations consumes 0.1ml of e-liquid or the equivalent of one cigarette; the PV itself stores typically 2ml of e-liquid, or the equivalent of twenty cigarettes; and the cartridge in the case typically stores approximately 10ml of e-liquid for compliance with EU Directive 2014/40/EU (known as the Tobacco Products Directive) or the equivalent of five packets of twenty cigarettes. Further, the case only needs to be re-charged (e.g. using a USB charging cable connected to a laptop or mains power adaptor) infrequently as well (perhaps once a week, depending on use).

This system is designed to re-fill and re-charge a PV many thousands of times without damaging either case or PV. This system gives the user an e-cigarette PV with the form factor of a conventional cigarette, and with the performance and user experience (e.g. vapour intensity) of a large modding kit-type PV, but with none of the inconvenience of dis-assembling the PV to re-fill the PV with e-liquid from a small bottle. This system also replicates the rituals of handling an object similar in size to a packet of twenty cigarettes, of opening that packet and withdrawing a cigarette; and the tactile familiarity of holding a cigarette sized object and inhaling from it. This combination is we believe key to the large-scale consumer adoption of e-cigarettes.

Section A. E-Liquid Re-filling and Re-Charging Storage and Carrying Case

In this **Section A**, we will describe the e-liquid re-filling and re-charging storage and carrying case. The case implements a number of useful features:

- Feature 1. Combined re-charge and re-fill storage and carrying case
- Feature 2. Case with movable PV holder
- Feature 3. Re-Filling the PV
- Feature 4. PV Locking mechanism
- Feature 5. Data connectivity
- Feature 6. E-fulfilment

In this Section A, we will summarise each of these six features in turn, and then describe them in detail. **Appendix 1** collects these features into a consolidated summary.

Feature 1. Combined re-charge and re-fill storage and carrying case

The feature is: A portable, personal storage and carrying case for an e-liquid e-cigarette PV in which the case includes: (a) a power source for re-charging a rechargeable battery in the PV; (b) a reservoir for holding e-liquid; and (c) a fluid transfer system adapted to transfer e-liquid from the reservoir to a chamber in the PV. The reservoir for holding e-liquid is, in one implementation, a user-replaceable e-liquid cartridge.

As noted above, this approach is key to an e-cigarette PV with the form factor of a conventional cigarette, and with the performance and user experience of a large modding kit-type PV: re-filling and re-charging of the PV is fast and convenient, since it can occur readily and easily whenever the user returns the PV to its case. The e-liquid cartridge in the case requires relatively infrequent (e.g. weekly) but fast, and mess-free replacement; it is far easier than re-filling manually by squeezing e-liquid from a small bottle. It may also have a simple relationship with conventional cigarette consumption (e.g. ‘one hundred cigarettes in a case’).

Note also that the two features of re-charging the PV’s battery and re-filling the PV’s e-liquid chamber have a working interrelation that produces an overall improved result –

we have a synergistic combination of features, entirely lacking for example in the non-analogous field of metered dose inhalers, exemplified by US 6637430 Ponwell.

Specifically, an effective e-liquid PV consumes a significant amount of e-liquid and also current. Cigalites have not sold well in the market because they permit neither high e-liquid consumption nor high current. Cases that can merely re-charge a PV are not good enough because the PVs need to be frequently re-filled with e-liquid, which means dis-assembling them, which is messy and inconvenient. But if you add an e-liquid re-filling feature to the case, as envisaged in this Feature 1, then that means you can run the heating element in the PV at a sufficiently high current to give much better performance – the fact that you are also now consuming more e-liquid since you are heating it faster and also now depleting the PV battery faster does not matter anymore because you can both conveniently re-fill the PV with e-liquid when you insert the PV back into the carrying case and also re-charge the PV battery. So adding an e-liquid PV re-fill capability has a working interrelationship with the PV battery re-charging function – it enables the PV to run at higher current and also higher juice consumption rates, giving much better vaping performance, but without the inconvenience of having to regularly dis-assemble the PV for re-filling or battery change.

Also, with this Feature 1, we can run the atomiser at the lower voltages (e.g. 3.3V) that likely produce no formaldehyde if we use low resistance wire in the atomiser - this not only produces no formaldehyde but will also produce warmer vapour and more vapour than would be made if the device were running at 5V.

Systems that do not have a combined re-fill and re-charge carry case cannot replicate this experience at lower voltages like 3.3V, because a 3.3V and low resistance wire combination means faster battery drain and faster e-liquid consumption than a higher voltage and higher resistance wire combination. As noted above, faster PV battery drain and faster e-liquid consumption are not disadvantages with the present Feature 1 because re-charging the PV and re-filling it with e-Liquid is fast and convenient and can happen readily whenever the PV is returned to the storage and carrying case.

Feature 2. Case with movable PV holder

The feature is: A portable, personal storage and carrying case for an e-liquid e-cigarette PV in which moving a movable holder or chassis, into which the PV has been inserted, brings electrical charging contacts on the PV into direct or indirect engagement with electrical charging contacts in the case that are connected to a power source, such as a rechargeable battery in the case.

By requiring the PV to be inserted into a movable holder or chassis in the case, it becomes much easier to guide the PV into accurate alignment with the electrical charging contacts in the case, as well as (preferably) guide an e-liquid filling aperture in the PV into accurate alignment with an e-liquid nozzle used to transfer e-liquid into the PV. Accurate alignment is highly desirable to ensure good electrical contact, to minimise leakage and to ensure optimum performance of the e-liquid fluid transfer mechanism.

Feature 3. Re-Filling the PV

The feature is: A portable, personal storage and carrying case for an e-liquid e-cigarette PV which re-fills the PV with e-liquid if the PV is inserted, fully or in part, into the case, whilst maintaining the PV whole and intact.

By ensuring that the PV remains entirely intact (in contrast for example to some medicinal inhalation devices which require a needle in the canister that stores medication fluids to puncture a rubber septum in the inhalation device), the design is robust and can be used for thousands of re-filling operations (as opposed to a very small number with a needle that punctures a rubber septum).

Another related high-level feature is: A portable, personal storage and carrying case for an e-liquid e-cigarette PV which re-fills the PV using a fluid transfer system, such as a pump activated by depressing and releasing the entire, complete PV, whilst the PV is held in a holder of the case in accurate alignment with the fluid transfer mechanism.

Using a holder to hold the PV in accurate alignment with a fluid transfer system is highly desirable to minimise leakage and to ensure optimum performance of the e-liquid fluid transfer mechanism, particularly where that mechanism is a pump activated by relative

motion of the PV against the pump, since if the PV is not aligned correctly (e.g. along the longitudinal axis of the pump nozzle), the pump may not operate efficiently and there may be leakage.

A related high-level feature is: An e-liquid e-cigarette PV adapted to be re-filled with e-liquid when inserted into a case, in which the PV includes an e-liquid filling aperture positioned centrally along the main axis of the PV to minimise any off-centre forces that could otherwise compromise e-liquid sealing.

Another high-level feature is: A portable, personal storage and carrying case for an e-liquid e-cigarette PV in which the case is adapted to transfer e-liquid to an e-cigarette PV from a user-replaceable e-liquid cartridge in the case.

If the case includes a user-replaceable cartridge, then it becomes fast and mess-free for the user to replace user cartridges and try new flavours or strengths of e-liquid by swapping out the cartridge. Since the cartridge capacity will be much greater than the PV's e-liquid chamber (for example, 10 ml for the user-replaceable cartridge as compared to 1 or 2ml in the PV chamber), replacement of the cartridge happens relatively infrequently – typically once every 5 days for a user replicating smoking 20 cigarettes a day. That also gives the user an easy to grasp measure of the effectiveness of any nicotine reduction program they are following – moving progressively from replacing a cartridge from every 5 days, to every 6 days, to every 7 days etc. For many ordinary users, this is an easy metric to follow.

Feature 4. PV locking mechanism

The feature is: A portable, personal storage and carrying case for an e-liquid e-cigarette PV which is adapted to lock the PV securely in a charging position; and when the PV is locked in the charging position, then electrical charging contacts on the PV are in direct or indirect engagement with electrical charging contacts in the case that are connected to a power source, such as a rechargeable battery, in the case.

By ensuring that the PV is locked in position, effective charging can occur and also the

risk of damaging the electrical contacts (on both PV and in the case) by inadvertent movement of the PV is reduced. That is especially important since the case is a portable storage and carrying case.

Feature 5. Case with data connectivity

The feature is: A portable, personal storage and carrying case for an e-liquid e-cigarette PV in which the case includes (a) user-replaceable e-liquid cartridge; and (b) a fluid transfer system adapted to transfer e-liquid from the cartridge to a chamber in the PV; in which the case includes a data processor that controls sending a signal requesting a replacement for the user-replaceable e-liquid cartridge in the case.

Enabling the case to send a request for a replacement e-liquid cartridge is very convenient for the user and also ensures that replacement cartridges are supplied in a timely manner – this is especially important when the user is on a tobacco or nicotine reduction programme since if the case runs out of e-liquid, then the user may well be tempted back to using cigarettes. So the efficacy of adopting this system as a cigarette replacement (and health concerns with cigarettes is overwhelmingly the reason given for e-cigarette adoption) benefits greatly from the timely, automatic, background ordering and supply direct to the end-user of replacement cartridges.

Feature 6. E-fulfilment Method

The high-level feature is: Method used in portable, personal storage and carrying case adapted specifically for a refillable e-cigarette PV and that re-fills and re-charges the PV, the method including the steps of the case (a) transferring e-liquid from a user-replaceable e-liquid cartridge to the PV and (b) automatically sending a signal requesting a replacement for the user-replaceable e-liquid cartridge to an e-fulfilment platform, either directly or via a connected smartphone. The method may include the steps of the case (a) detecting the level of or quantity of e-liquid in a user-replaceable e-liquid cartridge in the case and (b) automatically sending a signal requesting a replacement for the user-replaceable e-liquid cartridge to an e-fulfilment platform, either directly or via a

connected smartphone.

This feature is the method that is associated with Feature 5 and the same advantages apply. Note that 'detecting the level of or quantity of e-liquid in a user-replaceable e-liquid cartridge in the case' could be direct, or could be indirect, such as inferred from the number of re-fills of the PV that have been completed with that cartridge, or the total number of inhalations made with that cartridge.

Further optional features (each of which can be combined with any of the others high-level features 1 – 6 above) include the following:

- the movable chassis also has mounted on it an e-fluid reservoir, a battery, a printed circuit board and a fluid transfer mechanism
- a metered dose or quantity of the e-liquid is delivered by the fluid transfer mechanism in the case to the PV – typically 0.1ml per individual pumping action where a micro-pump is used.
- the portable re-filling case or unit comprises a holder for housing, securing or engaging with the personal vapouriser.
- the holder comprises a biasing means for receiving the personal vapouriser in a support position, the biasing means being arranged such that a user depressing the personal vapouriser causes the biasing means to allow the personal vapouriser to engage with the refill mechanism, in a refill position.
- the holder can be rotatably connected to the portable re-filling unit such that it can move between an open and closed configuration, the open and closed configurations having corresponding personal vapouriser positions, wherein in the closed configuration the personal vapouriser engages with the refill mechanism to receive a dose of substance and in the open configuration the personal vapouriser is disengaged from the refill mechanism.
- the refill mechanism comprises a pump.
- the refill mechanism comprises a refill valve.
- the refill mechanism is electronically controlled.
- the portable re-filling case further comprises a counter/measuring system for counting or estimating substance consumption-related data, such as the number of times a personal vapouriser has been refilled from the fluid reservoir.

- The counter/measuring system counts the number of times the personal vapouriser has been inserted into the unit for re-filling.
- the counter/ measuring system is resettable and the portable re-filling unit stores and/or displays a value provided by the counter/measuring system which corresponds to the number of times the personal vapouriser has been refilled from the fluid reservoir.
- The counter/measuring system directly measures consumption-related data by measuring the change in the amount of substance stored in the unit.
- the portable re-filling case or unit stores the consumption-related data and transmits that data to another device, such as a smartphone, using a wireless or non-wireless connection.
- the fluid reservoir is a liquid cartridge which is removable from the portable re-filling unit such that it can be replaced.
- The portable re-filling case or unit is further adapted to modify the amount of vapour fluid in a delivered dose of vapour fluid.

In the next section of **Section A**, we will detail the operation of the following features:

- | | |
|------------|--|
| Feature 1: | Combined re-charge and re-fill storage and carrying case |
| Feature 2: | Case with movable PV holder |
| Feature 3: | Re-Filling the PV |
| Feature 4: | PV Locking mechanism |

Features 1, 2, 3 and 4. Combined re-charge and re-fill storage and carrying case;
Case with movable PV holder;
Re-Filling the PV;
PV Locking mechanism

The following section describes the case and the PV in more detail, focusing on these four features. The relevant Figures are **Figures 6 – 10**.

A portable charging device for replenishing the e-liquid or vapour fluid of an e-cigarette PV comprises: an e-liquid reservoir for storing multiple dosages of e-liquid; and a refill mechanism configured to engage with the e-cigarette PV to deliver a dose of e-liquid from the reservoir to the e-cigarette PV.

Embodiments may provide a re-filling case for refuelling the e-cigarette PV with single dose (or predetermined by end user) multiple doses of e-liquid. The e-liquid may be supplied to the e-cigarette PV from a tank in the charging and re-filling case holding a larger reserve of e-liquid. The tank may be a user-replaceable cartridge.

A single dose of e-liquid delivered to the PV (and subsequently held in the e-liquid chamber within the PV) may be equivalent to a single measure of substance (such as the quantum of nicotine inhaled in one ordinary cigarette). Typically, 0.1ml is delivered using the micro-pump design described later in this section with each pumping action; this is equivalent to approximately ten puffs of a cigarette. The e-liquid chamber in the PV typically holds between 1ml and 3ml of e-liquid, very roughly equivalent to between ten and thirty cigarettes.

The fluid reservoir in the charging and re-filling case may store multiple dosages of e-liquid; the amount of e-liquid stored in the reservoir can be 10ml and is hence significantly greater than the fluid in a conventional cartridge or vial inserted into a conventional electronic cigarette. This makes re-filling the case with a fresh e-liquid cartridge far less frequent; with a conventional PV, the cartridge in the PV has to be replenished or replaced once that relatively small dose is consumed; with our approach, it is the cartridge slotted into the carrying case that has to be replaced and this is readily

done; as this holds far more than a conventional PV cartridge, replacement occurs far less frequently. Re-filling the PV occurs easily and quickly whenever the user inserts the PV back into the carrying case. This is not only more convenient for the end-user, but also significantly reduces waste. The cartridges are ideally fully recyclable.

A high-capacity e-liquid cartridge that is easily user-replaceable is especially important in a relatively low voltage, low resistance (e.g. closer to 3.3V than 5V; resistance closer to 2 ohms than 2.8 ohms or higher – typically 2.4 ohms – 1.9 ohms for 3.3V) since e-liquid consumption by the PV can be quite high. This high consumption would, with a conventional PV design be highly inconvenient because of the need to disassemble the PV and manually drip e-liquid into a small reservoir by squeezing a bottle of e-liquid. But it is no longer a problem because of the ease of re-filling the PV with e-liquid whenever it is slotted back into the case.

A user is also now able to monitor use of the PV (and hence nicotine use) in a similar way to conventional cigarette consumption. For example, a single dose may be equivalent to the amount of e-liquid required to simulate nicotine consumption equivalent to a single tobacco cigarette. With the micro-pump system described later in this section, pressing the PV down just once against the micro-pump causes approximately 0.1ml to be transferred from the case to the PV; this is approximately equivalent to ten puffs of a cigarette. The user could hence pump the PV down just once to transfer e-liquid equivalent to a single cigarette, or say five times for five cigarettes, or ten times for ten cigarettes.

In one design, the volume of e-liquid stored in the PV chamber may be equivalent to the volume of e-liquid required for an electronic cigarette to simulate a pack of twenty tobacco cigarettes. Therefore, the user may be able to conveniently regulate their consumption of nicotine via the PV. The maximum capacity of the e-liquid chamber in the PV could be 2ml, and hence very approximately equivalent to twenty cigarettes. This easy to understand equivalence to conventional cigarettes is important in enabling users to gauge their usage and hence important for nicotine reduction usage; users find correlating usage of conventional e-cigarettes to their previous tobacco consumption difficult and this lack of transparency inhibits broader adoption of e-cigarettes, despite

the significant body of scientific opinion that holds e-cigarettes to be very considerably safer than conventional cigarettes.

A single dose may also be any other quantity set as equivalent to a single dose, for example by the end-user, or automatically by the PV or its case if for example the end-user is following a nicotine reduction program. This generalisation applies throughout this specification and to all of the various innovative features described in it.

Embodiments may provide a rechargeable case battery where the portable charging and re-filling case is adapted to allow the PV to recharge its battery from the rechargeable case battery. The portable charging and re-filling case may offer the advantage that a user is able to simultaneously refill the PV with e-liquid and also recharge the battery of the PV. This ensures that, whenever the PV is withdrawn from the case, it can have sufficient e-liquid and power to provide a good vaping experience.

The portable charging and re-filling case may comprise a PV holder for housing the PV. The holder may support the PV in a specific position, provide storage, and enable refilling and charging of the PV.

The PV holder may comprise a biasing means for receiving a PV in a support position. The biasing means may be arranged such that depressing the PV causes the biasing means to allow the PV to engage with the refill mechanism, in a refill position. To refill the PV with a dose of vapour liquid the PV may be inserted into the holder. The holder may be a drawer such that when the PV is placed in the drawer, pushing the PV down allows the PV to engage with the refill mechanism so that e-liquid is pumped into the PV, filling the e-liquid chamber of the PV with one dose of e-liquid.

Alternatively, the PV holder may be rotatably connected to the portable charging and re-filling case such that the PV holder can move between an open and closed configuration, the open and closed positions having corresponding PV positions, wherein in the closed configuration the PV engages with the refill mechanism to receive a dose of e-liquid and in the open configuration the PV is disengaged from the refill mechanism.

The refill mechanism may comprise a pump. In such an example, interaction between the PV and the refill mechanism may cause the pump to deliver a measured dose of e-liquid to the PV. The refill mechanism may comprise a refill valve. The refill mechanism may be electronically controlled. A more detailed walk-through of the e-liquid transfer mechanism will be given later.

The portable charging device or case may comprise a counter/measuring system for counting the number of times the PV has been refilled from the e-liquid reservoir. The counter may be resettable and the portable charging and re-filling case may display a value provided by the counter corresponding to the number of times the PV has been refilled from the e-liquid reservoir in the case. The value may be the number of times the PV has been refilled from the reservoir since the last time it was reset, or it may be the total number of times a dose of e-liquid has been supplied by the reservoir by the refill mechanism. The data may be displayed or stored on a processor within the portable charging and re-filling case to be transmitted by wire or wirelessly to a secondary device for analysis and display, such as a smartphone, a wearable device, a portable computer or directly to the internet. Further, monitoring of usage may be used to determine when the e-liquid in the reservoir is nearly depleted and thus prompt the replacement of the fluid reservoir (by automatically ordering a replacement (or a week or a month's worth of replacements, or some other quantity, at the user's option) from an e-fulfilment platform that will then deliver direct to the user, or advising the user that a replacement will be needed, for example).

Embodiments may be further adapted to vary the amount of e-liquid in a single dose, and such variation may be based on prior usage of the PV (as monitored by a counter for example). In this way, the amount of e-liquid (or the concentration within the vapour fluid) in a delivered dose may be gradually reduced over time, helping a user to reduce consumption of a substance in the vapour fluid (such as nicotine or caffeine, for example). Such a concept may be extended to enabling a user to indicate a time period over which they wish to reduce consumption and by how much. Based on such an indication, an embodiment may moderate the amount of e-liquid in a single dose such that the desired reduction in consumption is achieved automatically, and over a set period of time or following a specific cessation program.

The e-liquid reservoir may be a liquid cartridge which is removable from the portable charging and re-filling case such that it can be easily and quickly replaced by a user, without mess or risk of spillage. Therefore, when the e-liquid reservoir is depleted a user may insert a new liquid cartridge so that the reservoir is replete.

The PV may comprise a liquid chamber for holding a dose of e-liquid, wherein the PV is adapted to engage with the portable charging and re-filling case in order to receive a dose of e-liquid from the fluid reservoir. The PV may comprise a PV valve.

Engagement of the PV valve and refill valve may allow a dose of e-liquid to be pumped from the reservoir of the portable charging and re-filling case to the fluid chamber of the PV. Therefore, when the PV is in or moved to a refill position, a dose of e-liquid may be delivered to the PV. When the PV is not engaged with the refill mechanism, the PV valve may be closed so that the e-liquid is stored in the PV.

In the following section, we will describe the PV and case, with reference to the Figures.

Referring to **Figure 6 and 7**, there is shown a portable charging and re-filling case 100 according to the invention. The portable charging and re-filling case 100 houses a fluid reservoir 3 and a rechargeable case battery 68 both of which are user-removable and replaceable. The PV holder or receptacle chassis 2 is a holder that is sized to securely hold the PV 1; it is shown in an open configuration and is adapted to store the electronic cigarette 1 or any other PV in a specific position that enables the PV 1 to accurately engage with and align against electrical charging contacts, data transfer contacts and e-liquid re-filling nozzle that are all in the case. The PV holder or receptacle chassis 2 in this embodiment is pivotally attached to the main body of the portable charging and re-filling case 100 such that in a closed configuration the PV 1 is stored securely within the casing of the portable charging and re-filling case 100.

In use, the e-cigarette PV 1 is placed in the electronic PV holder or receptacle chassis 2 and the chassis 2 is then moved to the closed configuration in order to store and/or refill the e-cigarette PV 1. In the closed configuration, the electronic cigarette 1 is in a refill position and can be depressed to engage with a fluid transfer mechanism to receive a dose of e-liquid from the fluid i.e. e-liquid reservoir 3 in the case 100 (typically, 0.1ml is

pumped across, as noted above, for each downwards pumping action). Alternatively, the electronic cigarette 1 may be refuelled upon insertion into the PV holder 2 using some other fluid transfer action, such as a pressurised pump, electrical pump, peristaltic pump etc.

The electronic cigarette 1 may also recharge not only its e-fluid chamber but also its internal battery 59 from the recharge case 100. This offers a user an advantage, in that it is no longer necessary to carry spare cartridges of e-liquid in order to refill the electronic cigarette 1 with e-liquid, or spare batteries to power the PV, as re-filling and re-charging can be achieved directly and without mess from the portable charging and re-filling case 100.

Figure 7 shows, at a schematic level, an example of the portable charging and re-filling case 100 in cross section, and an electronic cigarette 1 for use with the portable charging and re-filling case 100. The e-liquid chamber of the electronic cigarette 1 is adapted to receive and store a single dose of e-liquid fluid. The reservoir 3 of the portable charging and re-filling case 100 stores multiple doses of e-liquid and is connected to a dosed pump 4. The pump 4 includes a valve 34 and valve seals 13 & 14 and a bias spring 87. When the pump 4 is actuated, a dose of e-liquid is delivered from the portable charging and re-filling case 100 to the e-liquid chamber of the electronic cigarette 1 through hollow shaft 61.

The electronic cigarette 1 is placed into the PV holder 2 in a support position. In the support position, the electronic cigarette is disengaged from the refill mechanism. In an embodiment, a biasing member 87 prevents the electronic cigarette 1 from engaging with the refill mechanism 4 such that the electronic cigarette is maintained in the support position.

To actuate the pump 4, the electronic cigarette 1 is depressed. Depression of the electronic cigarette 1 overcomes the biasing force provided by the biasing member 87 and enables the electronic cigarette 1 to move to a refill position, or to re-fill by virtue of being depressed downwards.

When refilling, the electronic cigarette engages with the refill mechanism 4 to receive a dose of e-liquid. A counter (not shown; part of the electronics in the case) monitors the number of doses dispensed by the refill mechanism 4 and displays the value on a display in the case, and/or transmits by wire (e.g. USB) or wireless (e.g.. Bluetooth) the usage data to a secondary device (e.g. a smartphone) with a display, to the user. The counter may display the number of doses dispensed by the refill mechanism 4 since the counter was last reset and/or may display the total number of doses the refill mechanism 4 has dispensed. This offers the user the advantage of having the opportunity to monitor their consumption. The counter may indicate to a user when the fluid reservoir 3 holds a lower volume than a threshold value (e.g. when the vapour fluid in the reservoir is nearly depleted).

Detection that the amount of vapour fluid in the reservoir is below the threshold value may be used to prompt the replacement of the fluid reservoir, by automatically ordering the delivery of a replacement fluid reservoir for example.

In the **Figure 7** schematic, the chassis 2 is just a holder for the PV and the pump 4 mechanism; in the more detailed walk-through of the working device we will provide later in this Section A (e.g. **Figures 26 – 31**) the chassis also supports the case battery, electronics and e-liquid reservoir; this simplifies the connection between pump and e-liquid reservoir, eliminating the need for a flexible e-liquid pipe.

Figure 8 illustrates a further example of the portable charging and re-filling case 100 in use. Here, the PV holder 2 is rotatably connected to the portable charging and re-filling case 100 and swivels to an open configuration to accept the electronic cigarette 1. In order to refill the electronic cigarette 1 with e-liquid, the electronic cigarette 1 is placed into the PV holder 2 when the PV holder 2 is in the open configuration. The PV holder 2 is then moved to a closed configuration. The position of the electronic cigarette 1 in the closed configuration is such that the electronic cigarette 1 engages with the refill mechanism 4 to receive a specific or predetermined dose of e-liquid.

Figure 9 shows the interaction between the electronic cigarette 1 and the refill mechanism 4 in more detail. The refill mechanism 4 includes a hollow stem shaft 61 which engages with the electronic cigarette 1 when the electronic cigarette 1 is in the

refill position. Pushing the PV 1 down, into the refill position causes vapour fluid to be pumped from the fluid reservoir 3 to the electronic cigarette 1. In an example, the refill mechanism 4 is electronically controlled. For example, the pump 4 may be actuated or the refill valve 34 may open in response to a received signal.

Figure 10 shows the electronic cigarette 1 stored in the portable charging and re-filling case 100 in the refill position. When the PV holder 2 is in the closed configuration, e-liquid is pumped from the fluid reservoir 3 to the liquid chamber of the electronic cigarette 1 to refuel the electronic cigarette 1. For example, this can be achieved by the top 32 of the PV being pushed downwards by a camming action as the holder 2 is closed, overcoming bias spring 87. Or an electronic pump might be activated once the PV is in the closed configuration. Also, the electronic cigarette 1 may recharge its battery 59 from the rechargeable case battery 68 of the portable charging and re-filling case 100.

Referring to **Figure 11**, there is shown an electronic cigarette 1 for use with the portable charging and re-filling case 100. The electronic cigarette 1 has a liquid chamber 48 for storing a dose of e-liquid. The liquid chamber is connected to a PV valve 29. When the electronic cigarette 1 engages with the refill mechanism 4 of the portable charging and re-filling case 100, the PV valve 29 opens to allow a dose of e-liquid to enter the chamber 48. When the electronic cigarette 1 is not engaged with the refill mechanism 4, the PV valve 29 is closed so that the vapour liquid is stored in the liquid chamber and does not leak out.

It will be appreciated that the portable charging and re-filling case 100 is not limited in shape, and may not be rectangular. The refill mechanism 4 may not comprise a pump but some other kind of fluid transfer mechanism, and refilling of the electronic cigarette 1 with electronic cigarette fluid may be achieved by an alternative means. Further, the charging function may also occur using a charging station that is fixed (e.g. desktop based; plugged into a power socket) rather than using a portable charging and re-filling case.

For example, referring now to **Figures 12** and **13** there are shown modified embodiments where the PV holder 2 is not rotatably connected to the portable charging and re-filling case 100. More specifically, **Figure 12** shows an embodiment where the PV

holder is formed as a recess in the side the portable charging and re-filling case 100. The recess is adapted to receive a PV 1.

Figure 13 shows an alternative embodiment wherein the PV holder is formed as a cylindrical hollow barrel along the central longitudinal axis of a circular portable charging and re-filling case 100. A PV may be placed into the hollow barrel in a support position (as depicted in **Figure 13, left hand-side**). In the support position, the PV is disengaged from the refill mechanism.

In an embodiment, a biasing member not shown prevents the PV from engaging with the refill mechanism such that the PV is in a support position. To actuate the refill mechanism of the portable charging and re-filling case 100, the PV is pushed further in to the hollow barrel. Such further depression of the PV overcomes a biasing force provided by a biasing member and enables the PV to move to a refill position as depicted in **Figure 13, right hand-side**.

In the refill position, the PV engages with the refill mechanism to receive a dose of e-liquid from the reservoir of the portable charging and re-filling case 100.

Figure 14 shows that when the e-cigarette PV is depressed down onto the refill nozzle of the case, then case charge contacts electrically contact e-cigarette PV charge contacts, electrically connecting the electronic cigarette to the case battery so that the electronic cigarette can recharge its internal battery from the rechargeable case battery; hence, both the PV's battery as well as its e-liquid reservoir are replenished when inserted into the case. The electronic contacts can also provide the mechanisms through which the data is transferred from the PV to the portable case.

Non-pressurised pump technology can be used in this design to dispense a dose of a given volume of e-liquid. The device is made up of a single pump with a hollow control tube. The pump has a chamber with a predefined volume of e-liquid held for dispensing. When the PV is depressed, the e-liquid is forced under pressure from the e-liquid pump out through the pump nozzle and via a one way valve into the PV chamber. As the pump is released, it returns to its original state under a spring mechanism and in doing so draws liquid through the hollow control tube into the liquid chamber to replenish the

pump so that it is ready to transfer e-liquid into the PV on the next down-stroke of the PV.

The pump is preferably a pump termed a "high delivery" pump, which makes it possible to fill the bottle by actuating the pump only once. For example, a pump is suitably used having a delivery of 0.1ml per shot in order to feed the PV chamber.

The pump dosage volume can be predefined or variable dependent upon usage requirements. For variable dosage the travel of the pump can be variably limited with a screw type mechanism. e.g. half the normal pump travel = half the liquid intake and therefore expelled.

Pressurised pump technology may also be used: the liquid cartridge would be pressurised like a small aerosol to move predetermined volumes of liquid. The vapouriser would depress a valve that contains a liquid chamber. As the system is pressurised no 'pump' is required, instead fluid moves straight from the cartridge to the PV chamber, which is fixed in volume.

A Working System

In the following section, we will describe a working system. For clarity, we will capitalize defined terms, which are indexed in the Brief Description of the Drawings section. The relevant figures are **Figures 20 – 69**. We suggest reviewing these Figures using the index of defined terms as a first step in understanding the system.

The system comprises several main components, a Personal Vaporiser 1 and a portable, personal re-filling and re-charging Case 100. **Figure 20** shows a working, test prototype (i.e. not with the industrial design finishing of the final consumer product). The remainder of the engineering drawings will also relate to this test prototype. The case 100 is shown with a left hand side 6 and a right hand side 7. The case includes a Receptacle Chassis 2; the Receptacle Chassis 2 serves as the PV holder, securely holding the PV 1 when it is inserted into the case 6, 7. The Receptacle Chassis also serves as the mount on which are placed the e-liquid reservoir 3, fluid transfer mechanism 4, battery 68 and related components.

The entire Receptacle Chassis 2 rotates 15° about a Pivot Screw 18 inside a Case 6, 7 with the Receptacle Chassis 2 being Positively Biased Closed, 0° position, by a Leaf Spring 17 (first shown in **Figure 26**) attached to the Receptacle Chassis 2 via Screws 35 (first shown in **Figure 26**).

Figure 20 shows an isometric view of the case 100 with the Receptacle Chassis 2 fully closed; **Figure 21** shows an isometric view of case 100 with the Receptacle Chassis 2 rotated open 15° and showing the top of a PV 1 fully inserted into the PV holder portion of the Receptacle Chassis 2. **Figure 22** shows an isometric view of the case 100 with PV 1 slightly raised and ready for the user to withdraw from the case 100. The PV 1 has been heated to its operational temperature using the battery in the case and is 'ready to vape'. **Figure 23** shows an isometric view of the Receptacle Chassis 2 on its own. **Figure 24** shows an isometric view of the PV 1 (again, note that this is the test prototype and not the consumer version). The PV 1 has a Tip 32; at the end of the Tip 32 is a centrally positioned aperture through which e-fluid passes when re-filling the PV 1. A Seal Inlet 27 seals the aperture against the pump nozzle of the fluid transfer mechanism to prevent spillage or leakage of e-liquid. Three radially disposed vents are positioned around this central aperture; these are the vents through which vapour is inhaled. A Ring Connector Assembly 49 at the other end of the PV 1 provides electrical power and data contacts that engage with electrical power and data contacts in the Case 100. Tube body 56 contains all components.

Figure 25 shows a sectioned view of the PV 1. Starting from the left-hand side, Seal Inlet 27 seals the PV against a fluid transfer nozzle in the case; Valve 29 enables e-liquid to pass up into the PV and prevents it leaking out since it is biased in the closed position by Spring 30. Valve 29 only opens when the force exerted by the fluid, driven by the fluid transfer mechanism, exceeds the force of Spring 30. Grub screws 31 secures the Valve 29 and Spring 30 in position. An O-Ring 28 seals Tip 32 against the body of the PV 1. The atomiser includes a Coil and Wick Assembly 52 with a Vapouriser End Cap 50 and Vapouriser Insulating Sleeve 51. Fluid Chamber 48 stores e-liquid; the lengths of wicking element running parallel to the body of the PV are fully immersed in e-liquid in Fluid Chamber 48; the wicking element running perpendicular to the body of the PV, and around which the electrical heating element is wound, is not however immersed in e-

liquid, but draws e-liquid up from the limbs that are fully immersed. Further O-Ring 28 seal the e-liquid Chamber 48 from the rest of the Tube Body 56 of the PV 1. The Outer Body 53 of the PV surrounds the vapouriser.

Vaporiser Outer Body 53 and Vaporiser Inner Body 55 are insulated by Bush Vaporiser Body 54. Current is passed to the Vaporiser Inner Body 55 via a wire connected to PCB 60. One leg of the Coil 52 contacts the Vaporiser Inner Body 55, the other Coil Leg contacts Vaporiser Outer Body 53. This can be seen most clearly from **Figure 62**. The Vaporiser Outer Body 53 is connected to Earth.

A Pressure Sensor/Transducer 58 is mounted behind the Vaporiser Unit in the Pressure Sensor Housing 57. This is wired to the PCB 60. An Arduino Chip 66 mounted to the PCB 60 is used to monitor, control, set and feedback information pertaining to the vaping functionality.

A 3.7V 140mAh LiPo Battery 59 sits on the PCB 60. The far end of the PCB 60 is wired to Ring Connector 49 with 4 connections - 1 Power, 1 Earth, 2 Signal. Ring Connector 49 is made up of alternating Ring Contacts 42 and Insulation Rings 43, and is mounted on Screw 44 and terminates with End Cap 36.

When air is drawn through the PV 1, the Pressure Sensor/Transducer 58 activates, causing current to be sent to the Coil/Wick Assembly 52. The Coil heats the vaping fluid soaked wick, giving off vapour which entrains into the air stream.

O rings 28 seal the Vaping Chamber 48 from the air path. A unitary (and hence very strong) stainless steel Tube 56 houses all the parts mentioned above with a cut out to allow the RGB LED 64 to display the Status of the PV 1 for both battery power and vaping fluid level. A further small hole sits above the Reset Switch 65 mounted to the PCB 60.

The PV 1 charges its 140mAh Battery via the Ring Connector 49. Information is also fed back to the PCB Main Case 16 via 2 of the connections on the Ring Connector 49.

If we look now at **Figure 26**, we see a sectioned view of the case 100 with the Receptacle Chassis 2 fully closed into the case 100; the PV 1 is omitted for clarity. **Figure 27** shows a sectioned view of case 100 with the Receptacle Chassis 2 rotated open 15°, again with no PV inserted for clarity. To Load/Insert PV 1 into Receptacle Chassis 2 hand pressure is applied to the Lower Section of the exposed Receptacle Chassis 2. Receptacle Chassis 2 rotates 15°, using hand pressure, from its closed position, shown in **Figure 26**, to its "Open" position shown in **Figure 27**, with Leaf Spring 17 supplying a resistive force, bearing against Case 6 & 7 inner walls.

Figure 27 shows clearly how all critical components needed in the case 100 are mounted on the Receptacle Chassis 2. Key elements are the e-liquid pump 4, which sits in a void in the e-liquid cartridge 3. A hollow stem shaft 61 protrudes from one end of the pump 4, biased upwards by a spring; when a PV is depressed against this hollow stem shaft 61, it depresses that hollow stem shaft 61 downwards, forcing e-liquid within the pump 4 to travel up the hollow stem shaft 61 into the PV; the e-liquid cannot return back into the reservoir 3 because a ball valve 34 at the base of the pump 4 closes. Also mounted on the Receptacle Chassis 2 is the rechargeable battery 68 and a solenoid 22 that triggers an interlock mechanism, a lever or pawl 10 with a tooth at one end that rests against a sliding contact block 5. When the sliding contact block 5 fully engages with the PV, the pawl rises and locks against an edge of the sliding contact block 5, preventing it from moving back into the case 100 and hence locking the PV into position. Various PCB components are also shown mounted on the Receptacle Chassis 2, such as Microswitches 70, and PCB 16. Leaf Spring 17, mounted against Receptacle Chassis 2 with Screws 35, biases the Receptacle Chassis 2 in a closed position, as shown in **Figure 26**; it is shown in its opened position in **Figure 27**.

Moving to **Figure 28**, we now see the PV 1 fully inserted into Receptacle Chassis 2, which is fully closed within the case 100. The PV 1 is retained in position by a small ridge in the top of the sliding contact block 5 that engages with a channel around the top of the PV 1.

- There is no power from Receptacle Chassis 2 to Coil & Wick Assembly 52 or Solenoid 22. The system is in standby mode.
- Receptacle Chassis 2 is at closed 0° Position

- Pawl/Lever 10 is in its disengaged position, biased 6° to the horizontal by Spring 19
- 4 Way Sliding Contact Block 5 is pushed into contact with Ring Connector Assy 49 by Cam Block 8 – the action of rotating Receptacle Chassis 2 to Closed 0° position advances the 4 Way Sliding Contact Block 5 against Spring 23 (see **Figures 32 – 35** for more details on the operation of the 4 Way Sliding Contact Block 5).

Figure 29 shows the device in activated mode, with solenoid 22 activated and pawl/lever 10 activated, locking sliding contact block 5 in position.

- Power is supplied from Receptacle Chassis 2 to Solenoid 22. Power is supplied to Solenoid 22 when a small angular displacement of Receptacle Chassis 2 relative to Case 6 & 7 activates a Micro-switch 70 attached to Case 6 & 7
- Receptacle Chassis 2 is at the closed 0° Position.
- Pawl/Lever is pushed up into its engaged position, 0° to the horizontal, by Solenoid 22, locking the 4 Way Sliding Contact Block 5 into electrical contact with Ring Connector Assembly 49 (see **Figures 32 – 35** for more details on the operation of the 4 Way Sliding Contact Block 5). A mechanical interlock between 4 Way Sliding Connector Block 5 and PV 1 is therefore engaged.

Figure 30 shows the pre-heat mode: the Receptacle Chassis 2 is now fully opened; the PV 1 is locked in position and the sliding contact block 5 is also locked in position by pawl/lever 10; current is drawn from case battery 68 to heat the coil in the Coil and Wick Assembly 52 in PV 1.

- Power is only supplied from Receptacle Chassis 2 to Coil & Wick Assembly 52 when the Receptacle Chassis has rotated fully to its 15° to its Open position.
- Pawl/Lever pushed into its engaged position, 0° to the horizontal, by Solenoid 22
- The 4 Way Sliding Contact Block 5 is in electrical contact with Ring Connector Assembly 49. (See **Figures 32 – 35** for more details on the operation of the 4 Way Sliding Contact Block 5).
- The mechanical Interlock between 4 Way Sliding Connector Block 5 and PV 1 continues to be engaged.

Once pre-heating is completed, solenoid 22 releases pawl/lever 10 and sliding contact block 5 withdraws away from the PV 1, which is then biased to rise up slightly out of the case 100 by shaft 61 in pump 4, as shown in **Figure 31**. So **Figure 31** shows the activated mode.

- No power is supplied from Receptacle Chassis 2 to Coil & Wick Assembly 52 or Solenoid 22.
- Receptacle Chassis 2 is at Open 15° Position with PV 1 standing 3mm proud
- 4 Way Sliding Contact Block 5 is disconnected from Ring Connector Assembly 49 under pressure from Spring 23. (See **Figures 32 – 35** for more details on the operation of the 4 Way Sliding Contact Block 5).
- Pawl/Lever 10 is in its disengaged position, biased 6° from the horizontal by Spring 19
- Mechanical interlock between 4 Way Sliding Connector Block 5 and PV 1 is now disengaged.

Figures 32 – 37 show the operation of the 4 Way Sliding Contact Block 5.

The 4 Way Sliding Contact Block 5 connects Power, Earth and 2 Signal Input/Outputs from the PCB Main Case 16 to the PV PCB 60. A mechanical Interlock between the 4 Way Sliding Contact Block 5 and the PV 1 is incorporated in the design: the body 46 of the 4 Way Sliding Contact Block has a finger protrusion which engages with an undercut on the PV ring connector 49 providing the interlock facility. This is clearest when comparing **Figures 32- 34**, which show the finger protrusion locking into the PV, and **Figure 35**, which shows the 4 Way Sliding Contact Block 5 after it has slid back into the case and the PV 1 is now released.

The 4 Way Sliding Contact Block 5 is normally biased away from and out of contact with the Ring Connector 49 on the PV by a helical Spring 23 when mounted in the Receptacle Chassis 2 in the Open 15° position and with the Pawl/Lever in the disengaged 6° position – **Figure 35**.

The 4 Way Sliding Contact Block 5 is pushed into contact with the PV Ring Connector 49 when the Receptacle Chassis 2 is rotated back into the Case 6 & 7 to the Closed 0° position - e.g. when storing the PV, as shown in **Figures 32 - 33**.

A Cam Block 8 is fastened to the Case 6 & 7. When the Receptacle Chassis 2 rotates into the Case 6 & 7 the Spring 23 biasing the 4 Way Sliding Contact Block 5 is compressed as the 4 Way Sliding Contact Block 5 bears against the Cam Block 8.

The 4 Way Sliding Contact Block comprises 4 Contact Fingers 24 – **Figure 36** and **37** show these clearly, housed in Body - 4 Way Sliding Contact Block 46 and five Support Rings 45. Four wires are connected to the Contact Fingers 24. These connect back to pads on PCB Main Case 16. The 4 Way Sliding Contact Block 5 is limited to 2mm in its linear travel by Guide Plate 9.

Figure 38 is an exploded view of the case 100 and its components, the detailed operation of which has been described above. The Receptacle Chassis 2 forms the main housing for all the major components. When the device is built a Cover 12 is screwed into place. The Receptacle Chassis houses the PCB Main Case 16. This has a 650mAh battery 68 connected to it and a Micro USB Connector 67 for re-charging the main battery and communications. The PCB Main Case 16 fastens to the Receptacle Chassis 2 by means of PCB Standoffs 69. These also serve as the fixing holes for the Lid 12. Solenoid 22 is attached to the Receptacle Chassis 2 via the Solenoid Mounting Block 11, adjustment is provided via a slotted screw hole in the Solenoid Mounting Block 11. The PCB Main Case 16 has an Arduino Chip mounted to it controlling all electrical functions associated with the device. Consequently, it is possible for the user to alter the power delivered to the atomiser and hence customise the vaping experience to their specific preferences. The Arduino Chip can be controlled from a connected smartphone app., communicating with the Arduino Chip over Bluetooth LE. The following kinds of data could be tracked by the Arduino Chip and relayed to the user's connected smartphone app.:

- How many times the PV leaves the case
- Duration of PV out of case
- Internal clock used by the Arduino Chip stores data relative to first use, i.e. if unconnected for a few days it stores the data

- On pairing with phone GPS and time data
- Number of inhalations
- Duration of each inhalation
- Frequency of inhalation
- Depth of inhalation
- Power provided to the atomizer
- Current and/or voltage provided to the atomiser
- Battery power level – case and PV
- Number of times PV has been inserted and/or withdrawn from the case
- Number of times the PV has been pumped to re-fill it with e-liquid
- Vapes remaining (calculation from data)
- Cartridge e-liquid volume remaining – (calculation from data).
- Whether a fresh cartridge should be ordered
- Instruction to order a fresh cartridge
- Type of e-liquid used (e.g. strength, flavor, mixtures of different e-liquids)
- Unique ID in case and PV, so that the Case will only work with a designated PV

It would be possible also to include power control buttons, dials etc on the Case 100 itself, although this would add to complexity and cost. A Display is provided in the Receptacle Chassis to communicate the Device status to the user.

We will now look at the details of the fluid transfer mechanism. The relevant figures are **Figures 40, 41 and 42.**

Fluid transfer operation is as follows: the PV 1 is dropped into the Receptacle Chassis aperture 2 where it comes to a stop against the top of the Pump 4. Depressing the PV 1 further against the Pump 4 causes a further 3mm linear travel & the transfer of a metered dose of e-liquid vaping fluid from the Receptacle Chassis 2 to the PV 1. Approximately 0.1 ml of e-liquid is transferred per pumping action. The reservoir in the PV can typically store 1 or 2ml of e-liquid. The PV 1 Fluid Chamber 48 can be charged by repeatedly pushing the PV 1 down against the Pump 4.

Relaxing hand pressure on the lower section of the Receptacle Chassis 2 allows the Receptacle Chassis 2 to return to its closed 0° position under the Leaf Spring 17 force, closing the PV 1 into Receptacle Chassis 2 for secure storage. The device geometry ensures the top of the PV 1 Cams it in a downward direction against the top inside walls of the Case 6 & 7 when the Receptacle Chassis 2 is returned to its 0° closed position.

The case 100 can accept a custom designed 5ml Fluid Reservoir 3 which can be fitted and withdrawn from the Receptacle Chassis 2 by pushing in and pulling out. Other sizes of Fluid Reservoir 3 are also possible, typically up to 10ml. It is retained by means of a Moulded Rim 62 and Sealed to the Pump 4 my means of an integrally Moulded Lip Seal 63. Different types of Vaping Fluid can be easily changed with no disassembly of the Device required.

Figure 40 shows the loading - discharging position, with the Receptacle Chassis 2 at the Open 15° position. Pump 4 is mounted into Receptacle Chassis 2 and is sandwiched between Valve Mounting Cup 13 & Valve Mounting Cap 14. Reservoir 3 pushes into a slot in Receptacle Chassis 2 from beneath, with Moulded Rim 62 snapping into an undercut section in Receptacle Chassis 2. Reservoir Gasket 15 applies pressure on Moulded Rim 62 to maintain contact with the undercut. Reservoir 3 can be readily inserted and withdrawn by the user. Reservoir 3 has moulded Lip Seal 63 as an integral feature which seals against Pump 4. PV 1 is resting against Hollow Stem Shaft 61 of pump 4, but has not yet started to depress the Hollow Stem Shaft 61.

Figure 41 shows the re-filling position – with Receptacle Chassis 2 still at the Open 15° position. PV 1 is now shown flush with Valve Mounting Cup 13 & Pump 4. Hollow Stem Shaft 61 has been depressed down 3mm by the PV 1. Fluid passes up Pump 4 Hollow Stem Shaft 61 and Opens Valve 29 in PV Tip 32. Seal 27 bears against top of Pump 4 Hollow Stem Shaft 61. Valve 29 is moved off its seat by the pressure of the transferring e-liquid fluid. Spring 30 returns Valve 29 to its seat after pressure has equalised with Vaping Fluid entering Fluid Chamber 48.

Figure 42 shows the standby position - Closed 0° position. Hollow Stem Shaft 61 is fully depressed and PV 1 is in a dormant state. E-liquid previously pumped into the PV 1 is retained with the PV 1, so that it remains ready to use.

The detailed operation of the pump 4 will now be described. The relevant figures are **Figures 50, 51, 52** and **53**.

Figure 50 shows pump 4 at its start position, ready for initial priming.

The pump 4 has a non-return ball valve 34 at fluid inlet end 81 and a slide valve at fluid outlet end 82. The non-return ball valve 34 consists of a steel ball bearing that moves within a short slotted tube 83 with retaining barbs at one end and seats into a shallow taper at the other end, closest to the fluid inlet end 81.

The slide valve consists of a through-hole 84 in the piston rod 86 which is covered and revealed by the action of the piston 85 sliding backwards and forwards over the through-hole 84.

The pump has a piston assembly comprising a valve stem 88, a piston rod 86, a piston 85 and a bias spring 87. The valve stem 88 and piston rod 86 are permanently joined together and move as one. The piston 85 slides on the piston rod 86 and in the valve stem 88. A bias spring 87 keeps the piston 85 positioned forward, at the start position of its 3mm stroke, and covering the slide valve through-hole 84.

Exerting an axial force on the pump's valve stem 88 (e.g. as occurs when the PV 1 is pressed downwards into the Receptacle Chassis 2), causes the piston assembly to move forward inside the pump body, hence pressurising the fluid ahead of the piston 85 in the fluid chamber 80. Non-return ball valve 34 prevents fluid simply discharging back into the fluid reservoir 3.

As the hydraulic pressure increases, it overcomes the force exerted on the piston 85 by the bias spring 87, hence allowing the piston to move backwards relative to the piston rod 86.

Figure 51 shows the piston 85 at the end of its 3mm stroke; the bias spring 87 is now fully compressed, by 1.2mm. Piston return spring is now also fully compressed, by 3mm. The feed through-hole 84 in the piston rod 86 is exposed since the piston 85 has been forced backwards relative to the piston rod 86 by the increased hydraulic pressure, which exceeds that of the bias spring 87.

The pressurised fluid in the fluid chamber 80 can now escape through the exposed feed-through hole 84 and up the inside of the piston rod 86 and valve stem 88, as the piston assembly completes its stroke.

A metered volume (0.1ml) of e-liquid escapes into the PV 1 as the piston assembly reaches the climax of its stroke.

Figure 52 shows that as the hydraulic pressure drops below the bias spring force, this allows the piston 85 to slide forwards along the piston rod 86 and cover the feed-through hole 84. Fluid chamber 80 is now sealed at both ends.

Figure 53 shows removing the axial force on the valve stem; this allows the piston return spring 89 to send the piston assembly back to its start point. As the piston assembly moves back to its start point, a vacuum develops in the pump fluid chamber 80. This pulls the non-return ball valve 34 off its seat, allowing fluid from the reservoir to fill the void in fluid chamber 80.

The pump cycle is now complete. (As a preliminary step, cycling the piston assembly several times may be needed to dispel air from the fluid chamber 80 and replaces it with fluid. The fluid chamber 80 is now charged).

It is possible also to integrate the pump directly into the user-replaceable cartridge. That has some advantages – specifically, if the pump fails, then it is just the cartridge that needs to be replaced, not the entire case. Also, if the pump is part of the case, and different flavours of e-liquid are desired, that requires different cartridges to be swapped in to the case. There may be some residue of the previous flavour in the pump, possibly

affecting the vaping experience. Integrating the pump into the cartridge eliminates the problem of flavour tainting through previous e-liquid residue in the pump.

This variant is shown in **Figures 55 – 59**. The same 0.1ml pump is used and its operation is fundamentally as described above. The fluid reservoir 3 has a 5ml capacity and is formed as part of a body moulding. The body cavity is sealed with a valve cap 90 moulding, being ultra sonically welded to the body. Valve cap 90 at the fluid outlet end of the combined pump and cartridge locks the pump in position and also provides guidance for the valve stem 61.

The combined pump and cartridge includes an overflow valve. This is made up of a tapered valve seat 91 in the body moulding, a steel ball bearing 92 and return spring 93. The tapered valve seat 91 is at the end of a bore slightly larger than the bore of the steel ball bearing 92. There are channels cut into the bore to allow for the flow of fluid in the bypass condition. The taper is 180° juxtaposed from the non-return valve taper.

In normal operation, the overflow valve ball 92 remains seated in its tapered housing kept in place by the return spring 93. If a condition arises where the hydraulic pressure in the pump fluid chamber 80 exceeds the design pressure, the overflow valve ball 92 is forced off its seat against resistance offered from the return spring 93. Fluid can pass the steel ball 92 and return to the reservoir chamber 3 – this is the bypass condition.

The integrated pump/reservoir/overflow valve can be in one of five different conditions:

Start position – as shown in **Figure 55**.

- pump fluid chamber 80 is in charged state.
- Non-return valve ball 34 is seated in its tapered housing.
- overflow valve ball 92 is seated in its tapered housing.
- pump piston assembly is covering slide valve fluid feed through hole 84.
- fluid in pump fluid chamber 80 is in a sealed state.

Open position – as shown in **Figure 56**

- pump piston assembly is travelling through it's 3mm downstroke.
- hydraulic pressure inside pump fluid chamber 80 has overcome the bias spring 87 force allowing upward movement of piston 85.
- slide valve has opened, allowing flow of fluid from pump fluid chamber 80 to fluid outlet port 82 via fluid feed through hole 84.
- non-return valve 34 remains closed
- overflow valve 92 remains closed

Down position – as shown in **Figure 57**

- bias spring 87 has closed slide valve with piston 85 covering fluid feed through hole 84.
- fluid chamber 80 volume of fluid has been depleted by 0.1ml.
- remaining fluid in fluid chamber 80 no longer pressurised.
- piston return spring 87 is compressed and exerting an upward force on piston assembly 85.

Bypass position (this is conditional on the hydraulic design limit being exceeded and hence protects against damaging the pump 4 and the PV 1) – as shown in **Figure 58**

- slide valve is in the open position, with piston 85 not covering fluid feed through hole 84.
- hydraulic pressure inside pump fluid chamber 80 and valve stem 88 exceeds design pressure.
- non-return ball valve 34 is closed.
- pressure relief overflow valve 92 opens against pressure from return spring 93. Ball valve 92 is forced off it's seat by excessive hydraulic pressure in the pump fluid chamber 80. Fluid flows around ball valve 92, through channels and back into reservoir 3.

- once sufficient volume of fluid has been expelled from pump fluid chamber 80 into reservoir 3, the hydraulic pressure diminishes in pump fluid chamber 80, allowing pump piston assembly to complete it's stroke. The bias spring 87 pushes the 85 piston over fluid feed-through hole 84, closing the sliding valve.
- pump is now in “down” condition.
- both “open” and “bypass” positions precede “down” position.

Return position – as shown in **Figure 59**

- axial force has been removed from valve stem 88.
- pump piston assembly returns to it's start position under return spring 89 force.
- a vacuum in the pump fluid chamber 80 develops in the wake of the pump piston assembly returning to it's start position.
- vacuum causes non-return valve ball 34 to move off it's tapered seat, allowing fluid from the reservoir 3 to fill the void.
- pump fluid chamber 80 is now charged and non-return valve ball 34 settles into it's seat.
- pump is now in the start position.

We will now look closely at the PV 1 itself.

We earlier looked at a section view of the PV 1 (**Figure 25**). **Figure 60** shows an exploded view of PV 1 and **Figure 61** shows an isometric view of PV 1. **Figure 62** shows one design of atomiser assembly. The PV 1 includes a PV Tip 32 containing Valve 29, Valve Spring 30 and Grub Screw 31. PV Tip 32 also has 3 concentric holes, connecting to Air Way, which allow Vaporised Liquid to be inhaled. In this design of atomiser, the heating coil is perpendicular to the long axis of the PV 1. **Figure 63** shows an alternative design in which the wicking material has the same ‘U’ shape, but also includes a long element running along the long axis of the PV 1. Heating coil 98 is wound around this long element and the Coil & Wick Assembly 52 then retained by

chassis 99. The advantage of this alternative design is that a longer heating coil 98 can be used, and airflow over the heated coil 98 should be more uniform and effective since the coil runs parallel to the airflow instead of perpendicular to it.

For both the perpendicular and parallel arrangements, the vaporiser sits behind the Tip 32, and is made up of a Coil & Wick Assembly 52, Vaporiser Outer Body 53 and Vaporiser Inner Body 55. These are insulated by Bush Vaporiser Body 54. Current is passed to the Vaporiser Inner Body 55 via a wire connected to PCB 60. One leg of the Coil 52 contacts the Vaporiser Inner Body 55, the other Coil Leg contacts Vaporiser Outer Body 53. This can be seen most clearly from **Figure 62**. The Vaporiser Outer Body 53 is connected to Earth.

A Pressure Sensor/Transducer 58 is mounted behind the Vaporiser Unit in the Pressure Sensor Housing 57. This is wired to the PCB 60. An Arduino Chip 66 mounted to the PCB 60 is used to monitor, control, set and feedback information pertaining to the Vaping Functionality.

A 3.7V 140mAh LiPo Battery 59 sits on the PCB 60. The far end of the PCB 60 is wired to Ring Connector 49 with 4 connections - 1 Power, 1 Earth, 2 Signal.

When air is drawn through the PV 1, the Pressure Sensor/Transducer 58 activates, causing current to be sent to the Coil/Wick Assembly 52. The Coil heats the vaping fluid soaked wick, giving off vapour which entrains into the air stream.

O rings 28 seal the Vaping Chamber 48 from the air path. A unitary (and hence very strong) stainless steel Tube 56 houses all the parts mentioned above with a cut out to allow the RGB LED 64 to display the Status of the PV 1 for both battery power and vaping fluid level. A further small hole sits above the Reset Switch 65 mounted to the PCB 60.

The PV 1 charges its 140mAh Battery via the Ring Connector 49. Information is also fed back to the PCB Main Case 16 via 2 of the connections on the Ring Connector 49.

We will now look at the Ring Connector 49 in more detail. **Figures 65 & 66** are the relevant figures.

The Ring Connector Assembly allows the PV 1 to be placed in the Receptacle Chassis 2 in any orientation without it affecting its connectivity. Four Ring Contacts 42 with different length Pins 38, 39, 40, 41 soldered to them are separated by three Insulating Rings 43 which in turn are housed in End Cap - Ring Connector 36. This ensemble is capped with PCB Mounting Cap / Ring Connector 37 fastened with a Screw 44. A wire is soldered to each of the Pins 38, 39, 40, 41 which are then soldered to Pads on PCB 60. The Ring Connector Assembly also has 2 off 1.7mm Slots which captivate the PV PCB 60. The Ring Connector Assembly is a push fit in the end of the Tube Body - Vaporiser 56.

We will now look at a variable air intake feature. Altering the airflow allows the user to customise the vaping experience to their specific preferences; for example, an experienced vapour looking to produce large quantities of vapour with a variable voltage modding kit type PV might set the voltage used to a much higher power than normal and he would manually fix an air intake that would him to breath in a large volume of vapour. Swapping different air-intakes is generally a matter of screwing out the unwanted air intake and screwing in an air-intake with the required air-hole size(s). One variant of the PV has a variable air intake system in which the casing comprises an inner and an outer tube; the inner tube has a matrix of air-intake holes which can be lined up with air-intake holes in an outer-tube; the user rotates the outer tube until the desired number of holes are lined up. For example, the inner tube could have a regular, square-arrangement or matrix of holes consisting of 6 holes formed radially at 30° intervals repeated over 6 rows. The outer tube then has a square matrix of holes consisting of 6 holes formed radially at 30° intervals repeated over 6 rows. The outer tube slides over inner tube until top rows of holes coincide. The outer tube can be rotated in 30° increments to reveal 0, 1, 2, 3, 4, 5 or 6 columns of holes in inner tube thereby varying cross sectional area of air able to enter the vaporiser body. **Figure 67** shows two rows of holes lined up and **Figure 68** shows 5 rows lined up.

Another variant, shown in **Figure 69**, comprises 2 tubes – inner and outer. The inner tube has a square matrix of holes consisting of 6 holes formed radially at 30° intervals repeated over 6 rows. The outer tube has helical matrix of holes consisting of 1 hole per row formed radially at 30° intervals repeated over 6 rows - 6 holes in total. The outer tube slides over inner tube until top rows of holes coincide. The outer tube can be rotated in 30° increments to reveal 0, 1, 2, 3, 4, 5 or 6 columns of holes in inner tube thereby varying cross sectional area of air able to enter the vaporiser body.

We will now walk through the electrical functionality of one implementation. Note that some simplification may be used in the consumer product; what we will describe below is the prototype implementation, which has been optimised for testing.

The steps or logic is as follows:

- 1) The device starts in standby mode and is therefore inactive
- 2) The user activates the PV 1 by pressing a microswitch 70, protruding from a slot in the outer case 100.
- 3) A solenoid 22 mounted on the Receptacle Chassis 2 is powered from battery 68, itself also mounted on Receptacle Chassis 2.
- 4) Solenoid 22 locks 4 Way Sliding Contact Block 5 against the PV Ring Connector 49.
- 5) Power to solenoid 22 is limited to 10 seconds unless the Receptacle Chassis 2 is rotated 15°.
- 6) Receptacle Chassis 2 is rotated 15° against resistance of leaf spring 17 (the user squeezes the bottom of the Chassis into the Case 100).
- 7) Microswitch 70 activates closing contacts at termination of 15° travel.
- 8) Upon Microswitch activation, power is sent from Battery 68 to the coil and wick assembly 52 in the PV 1, via 4 Way Sliding Connector 5 and the PV Ring Connector 49.
- 9) The PV coil 52 temperature is monitored by on board electronics (directly or indirectly as a function of power delivered and time).
- 10) The power supply to the coil 52 is terminated when the coil 52 reaches its operational temperature, or a defined time has elapsed sufficient for the coil to reach operational temperature; generally this is achieved in under 1s or 2s.

- 11) The power supply to Solenoid 22 is then terminated, unlocking 4 Way Sliding Connector 5.
- 12) 4 Way Sliding Connector 5 then retracts 2mm under spring 23 force, breaking both electrical connection between PV PCB 60 and the EPV Main Chassis PCB 16 and also terminating the mechanical interlock between the PV 1 and 4 Way Sliding Contact Block 5.
- 13) The PV 1 then springs upwards and clear of the Receptacle Chassis 2, ready for removal.
- 14) The PV 1 is then removed from Receptacle Chassis 2 by the user and placed between lips.
- 15) The user inhales on the mouthpiece of PV 1.
- 16) Air Pressure Sensor 58 in the air stream inside PV 1 senses air movement and sends power to vaporiser Coil 52.
- 17) The PV 1 on-board Battery 59 supplies power to vaporiser Coil 52.
- 18) The PV 1 vaporiser Coil 52 temperature is monitored by on-board electronics whilst there is air flow.
- 19) The PV 1 vaporiser Coil 52 temperature is controlled by cutting & re-instating power from on-board battery 59.
- 20) After cessation of vaping, the PV 1 is placed back in the Case 100, i.e. Receptacle Chassis 2.
- 21) The Receptacle Chassis 2 returns to its Standby Mode Position, 0°, under Spring 17 power.
- 22) A camming action of the Receptacle Chassis 2 closing against Outer Case 6 & 7 imparts linear travel to EPV.
- 23) Linear travel causes pump 4 to transfer vaping liquid to replenish the PV 1 on-board reservoir.
- 24) PV 1 is returned to standby mode – inactive in the case.

One further feature is that the vaping experience is a function of a number of variables, such as e-liquid constituents, power delivered to the atomiser, temperature reached, airflow etc. It is possible for the case to store different profiles, such as 'light', 'smooth', 'intense', 'maximum vapour quantity', 'maximum strength', 'warmer vapour', 'cooler

vapour' etc. Each of these could also be a function of a specific brand of e-liquid. The user can then select on their smartphone app the specific profile and/or variables that meet their preferences.

Also, the specific brands of e-liquid could themselves determine specific variables of the case and PV. Hence a user could select on their smartphone app to use say a 'Marlboro' brand of e-liquid, and then the case would automatically configure parameters such as power, temperature etc to give the ideal experience for that specific brand. The parameters could be stored in software or firmware in the case or the PV. It would also be possible to obtain an application from an app store, such as the Apple App Store, or Google Play, specific to a brand of e-liquid; this app would then automatically configure the connected case with the appropriate parameters for optimum performance for that brand of e-liquid.

In the preceding part of **Section A**, we detailed the operation of the following features:

- Feature 1: Combined re-charge and re-fill storage and carrying case
- Feature 2: Case with movable PV holder
- Feature 3: Re-Filling the PV
- Feature 4: PV Locking mechanism

In the following part of **Section A**, we will look at:

- Feature 5. Data connectivity
- Feature 6. E-fulfilment

Features 5 & 6. Case with data connectivity and E-fulfilment

In this section, we describe in more detail the features of data connectivity and e-fulfillment, first introduced at the start of **Section A**.

To re-cap on the data connectivity feature: this is a portable, personal storage and carrying case for an e-liquid e-cigarette PV in which the case includes a data processor that controls sending a signal requesting a replacement for a user-replaceable e-liquid cartridge in the case.

The related e-fulfilment method is a method used in portable, personal storage and carrying case adapted specifically for a refillable e-cigarette PV and that re-fills and re-charges the PV, the method including the steps of the case (a) transferring e-liquid from a user-replaceable e-liquid cartridge to the PV and (b) automatically sending a signal requesting a replacement for the user-replaceable e-liquid cartridge to an e-fulfilment platform, either directly or via a connected smartphone.

The method may include the steps of the case (a) detecting the level of or quantity of e-liquid in a user-replaceable e-liquid cartridge in the case and (b) automatically sending a signal requesting a replacement for the user-replaceable e-liquid cartridge to an e-fulfilment platform, either directly or via a connected smartphone. Note that ‘detecting the level of or quantity of e-liquid in a user-replaceable e-liquid cartridge in the case’ could be direct, or could be indirect, such as inferred from the number of re-fills of the PV that have been completed with that cartridge, or the total number of inhalations made with that cartridge, or any other way of intelligently determining whether a replacement cartridge should be ordered. Machine learning can also be deployed to analyse the user’s usage patterns; for example, if the user tends to vape heavily over the weekend but quite lightly during the week, then that can be taken into account when determining when a replacement cartridge should be ordered. Likewise, a degree of direct interaction between e-liquid vendors and end-users is possible; when a user is likely to be ordering replacement cartridge(s), then special offers, or offers for new flavours or new strengths of e-liquid can be sent (e.g. text, instant message etc) to the user, or any other way of cementing brand loyalty.

Enabling the case to send a request for a replacement e-liquid cartridge is very convenient for the user and also ensures that replacement cartridges are supplied in a timely manner – this is especially important when the user is on a tobacco or nicotine reduction programme since if the case runs out of e-liquid, then the user may well be tempted back to using cigarettes. So the efficacy of adopting this system as a cigarette replacement (and health concerns with cigarettes is overwhelmingly the reason given for e-cigarette adoption) benefits greatly from the timely, automatic, background ordering of replacement cartridges.

Optional features (each of which can be combined with others) include the following:

- the data is substance-consumption related data
- the cartridge(s) are in normal use replaceable by a user but are not refillable by a user.
- the processor is programmed to send data over a wire or via a wireless data connectivity interface.
- the processor is programmed to send and/or receive data from the personal vapourising device.
- the processor, or an associated processor, is programmed to determine and store when the case is opened and/or shut.
- the processor, or an associated processor, is programmed to measure or record the charge level of a battery in the portable re-filling unit and also the charge level in a battery in the personal vapouriser.
- the processor, or an associated processor, is programmed to detect cartridge type and volume.
- the portable re-filling unit is adapted to receive substance consumption-related data from the personal vapouriser.
- the processor, or an associated processor, is programmed to measure consumption of the or each substance, including related factors, such as time, location, temperature.
- the processor, or an associated processor, is programmed to output consumption-related data, organized according to any one or more of the

following variables: part of the day/night, daily, weekly, seasonal, weather, any other factor.

- the processor, or an associated processor, is programmed to control any one or more of: mixing of e-liquids from different cartridges in the re-filling unit; nicotine or smoking cessation or reduction, period between 'vapes'; re-ordering e-liquid; age/parental controls, social network updates; e-liquid recommendations.
- the processor, or an associated processor, is programmed to use the consumption-related data for the or each substance in an algorithm that calculates when to place an order for one or more replacement cartridges or prompt a user that one or more replacement cartridges should be ordered.
- The processor, or an associated processor, is programmed to order replacement cartridges when running low, either by directly sending a request to a fulfillment server, or sending a message to a connected smartphone or wearable device, for the smartphone or wearable device to send a request to a fulfillment server.
- the processor, or an associated processor, is programmed to control mixing and consumption of the or each substance.
- the processor, or an associated processor, is programmed to use location data, such as location data from a GPS or other satellite or land-based location-finding system.
- the location data is from a location finding system in the portable re-filling unit itself or the personal vapouriser.
- the processor, or an associated processor, is programmed to provide an alert to the user, directly or via a smartphone or wearable device, if close to a retail store where consumables for the personal vapouriser are obtainable.
- the processor is programmed to send and/or receive data with a tablet, smartphone, wearable device or any other secondary computing device, or with a personal vapouriser.
- the tablet, smartphone, wearable device, PC, laptop or other secondary computing device is programmed (e.g. with a downloadable app) to perform any of the functions listed above - i.e. the existing computational power and 3G/4G wireless connectivity and GPS capability of the tablet/smartphone etc. is used instead of having to build that capability into the re-filling unit.
- the processor, or an associated processor, is programmed to provide data to

and/or receive data from a downloadable smartphone application.

- the downloadable smartphone application can control the portable re-filling unit.
- the downloadable smartphone application can control any one or more of: mixing of e-liquids from different cartridges in the re-filling unit; nicotine or smoking cessation or reduction, period between ‘vapes’; re-ordering e-liquid; age/parental controls, social network updates; e-liquid recommendations; parameters that determine PV performance or the vaping experience (e.g. power, temperature, airflow).
- the processor is programmed to integrate with a personal assistant program such as Google Now, Apple Siri, etc.
- the portable re-filling unit can be remotely locked and unlocked from the smartphone application, such as by entering a PIN.
- the portable re-filling unit can be remotely locked and unlocked from the smartphone application or other remote device, to prevent release of the vapourising device from the re-filling unit, as an aid to cessation or reduction of substance usage, to prevent tampering, to prevent access by children.
- the portable re-filling unit can be remotely locked and unlocked automatically depending on whether a smartphone paired with the unit is within a specified range or is able to exchange appropriate data with the unit.
- the data is sent over a wireless link, or a direct electrical connection

The following section describes these features with reference to the Figures; the relevant Figures are **Figures 70** and **72**.

Figure 70 is a high-level schematic showing a portable re-filling case able to communicate wirelessly and also through a wired connection to a smartphone, a laptop and a modem; these devices send data via the internet or other network – this can be any of the consumption data (including how consumption varies according to the various parameters, such as part of the day/night, daily, weekly, seasonal, weather, time, location, temperature and any other factor). This data is especially valuable to PV vendors, especially if it can be associated with a demographic profile of the device user; that demographic profile can be entered by the user when they register their device online (e.g. on first purchase of the PV, or when they wish to buy e-liquids, or set up automatic e-fulfillment of replacement e-liquid), or can be extracted or inferred from social network

posted information. The data can also be used by an e-fulfillment company to process the order and to provide replacement consumables (e-liquid, PV, case) to the user.

Figure 72 shows schematically that the portable re-filling unit includes electronics componentry, such as a memory, wireless/wired connectivity, software, and a controller/processor. Also, the cartridge includes four compartments, each with a different flavor or strength of e-liquid; the case is able to monitor the consumption of e-liquid in each compartment and share that consumption data with the connected smartphone app, as well as the e-fulfillment platform.

The re-filling unit itself can measure how much e-liquid is left in its cartridge(s) or tank(s). There are various ways of doing so:

1. Ultrasonic ranger for depth, some a tilt sensor to detect the angle of the cartridge and whether the e-liquid closes an electrical circuit between different electrical contacts at different levels within the cartridge.
2. Measure the weight of the tank(s)
3. Capacitive sensor. As the e-liquid has a different permittivity with respect to air, if concentric circles of conductors are kept in a vertical position, a height change in e-liquid will result in a proportional change in capacitance between the conductors. This can be fed to a circuit which can detect the change and thereby a change in e-liquid level.
4. Using an air pressure sensor at the top of a flexible tube whose bottom is held just above the bottom of the tank. The pressure in the tube changes as the e-liquid level goes up and down. This would be very safe, inexpensive, rugged and reliable.

Each of these techniques can also be used in the PV itself.

Section B. PV: Simplicity and Ease of Use

Preceding **Section A** focused on aspects of the re-filling and re-charging case. We will now move on, in this new **Section B**, to describing various features in the e-cigarette PV itself. The PV implements a number of useful features that contribute to the user experience, defined by simplicity and ease of use.

Following on from the consecutive numbering used in **Section A**, these features are:

- Feature 7. Re-fillable and re-chargeable PV
- Feature 8. PV with pre-heat
- Feature 9. PV with dosage indication
- Feature 10. PV with drip prevention

We will look at each of these in turn.

Feature 7. Re-fillable and re-chargeable PV

A significant problem with conventional e-cigarette PV designs is that re-filling a cartridge reservoir is slow and can be messy; it typically requires the user to purchase small bottles of e-liquid and to carefully dis-assemble the PV and then re-fill the cartridge by lining up the nozzle of a bottle and squeezing gently. Equally, removing a spent, non-refillable cartridge and replacing it with a new cartridge, whilst not messy, is wasteful, especially as typical cartridges are not recyclable.

The feature is a re-fillable and re-chargeable e-cigarette PV that is not disassembled in normal use for re-filling or replenishing with e-liquid and is also not disassembled in normal use for battery access or replacement or other battery interaction.

A second aspect of this feature is a re-fillable and re-chargeable e-cigarette PV with a casing that includes a rechargeable battery, a re-fillable e-liquid reservoir and an atomiser, none of which are removable from, or separable from, any part of the casing in normal use. The body of the casing may be a one-piece, unitary casing (typically circular or square in profile), with components introduced from either or both ends.

A third aspect of this feature is a re-fillable and re-chargeable e-cigarette PV designed in normal use to only be re-fillable with e-liquid and re-chargeable when inserted into or otherwise engaged with a carrying case for the PV, the carrying case being specifically adapted to re-fill and re-charge the PV.

Ensuring that the PV does not need to be dis-assembled in normal use, for charging or re-filling e-liquid, leads to a much simpler user experience. Furthermore, it enables the design to be much more robust, since there need be just a single, strong unitary casing with no screw threads allowing dis-assembly; robustness is very important for a consumer device that will be returned to and withdrawn from its case thousands of times, dropped and generally not treated gently.

A fourth aspect of this feature is a re-fillable and re-chargeable e-cigarette PV with a tip that includes (a) an e-liquid filling aperture that is designed to engage an e-liquid transfer mechanism (b) one or more vapour outlets distributed around the e-liquid filling

aperture; and electrical charging contacts spaced apart from the tip.

The relevant Figures are **Figures 7 – 11**. **Figure 7** shows the PV case 100 which serves also as a e-liquid re-filling unit; it includes a replaceable e-liquid cartridge 3 and a battery 68 that can re-charge the battery in the PV 1. **Figure 7** is a cross-section view of the re-filling unit 100 and the PV 1; **Figure 8** shows the PV 1 being inserted into the re-filling unit 100; **Figure 9** shows the pump action dispenser in the re-filling unit 100 automatically replenishing the e-liquid reservoir in the PV 1 whilst the PV 1 is being pushed down; **Figure 10** shows the PV 1, fully replenished, and stored in case 100 (when the PV 1 is stored in the case, PV 1 is also pushed down to activate the pump dispenser to ensure the PV 1 is fully replenished with e-liquid).

PV 1 is not dis-assembled in normal use for re-filling the reservoir or otherwise replenishing or replacing the substance. The battery 5 in the re-filling unit 1 also charges the battery in the PV 1 whilst PV 1 is stored in the re-filling unit 1.

The detailed design of the working prototype, shown in **Figures 24** and **25** and fully described in **Section A** above, also exemplifies the above features.

Feature 8. PV with Pre-heat

Conventional e-cigarettes often only start heating the atomiser once an inhalation is detected; as a result, the first inhalation can give quite a poor experience and it is only after two or three inhalations that the atomiser has sufficiently heated the e-liquid that a good vaping experience is provided.

In this section, we describe a number of different 'pre-heat' features. With these 'pre-heat' feature, because the PV can start heating automatically, there is no need for an 'on' switch in the PV, contributing to the simplicity of the user experience, and also reducing cost.

The first pre-heat feature is a portable, personal storage and carrying case for an e-liquid e-cigarette PV that starts providing power to heat an electrical atomising element in a PV automatically when the case in which the PV is stored is opened. By using the battery in the case to provide the power for this pre-heating, this saves depleting the battery in the PV.

The second 'pre-heat' feature is an e-cigarette PV that automatically heats an electrical atomising element when the PV detects that it is no longer in electrical contact with the charging contacts in a portable carry case in which it is stored (e.g. when the case is opened and the PV pops up out of the case).

The first and second pre-heat features can be combined – e.g. the first phase is for the battery in the case to provide power for pre-heating when the case is opened; the second phase is for the battery in the PV to take-over heating when it detects that the PV is no longer in contact with the electrical power contacts in the case and hence can no longer rely on power from the case. Normally, this second phase occurs only once the pressure sensor in the PV detects that the user is inhaling.

A third pre-heat feature is a portable, personal storage and carrying case for an e-liquid e-cigarette PV which includes a locking system to lock the PV securely in a heating position during which time the PV is heating using power from a power source in the

case and, after the PV has been sufficiently heated, to release the locking mechanism. The case automatically may move the PV to a position which allows it to be readily removed from the case by an end-user once the PV has been sufficiently heated. The user can also press the PV back down when it is in the case to initiate heating.

In this section, we also introduce the feature of the PV automatically indicating when it has reached the correct operating temperature: A personal vapourising device storing a substance to be vapourised, the device including a means of indicating by visual cue, audible cue, touch feedback, haptic, vibration, heat or other sensory signal, or prompt, when the device has sufficiently heated the substance to a predetermined temperature or for a predetermined time, so that the device is ready for use. Hence, the PV (or indeed the case) may show when the PV is ready for use because heating to an operational level has been reached or heating for a predefined time has occurred. For example, a simple LED may glow when the PV is ready for inhalation.

This kind of indicator is very useful because if the user tries to inhale before the atomizer is effectively able to create a vapour with the correct characteristics (which happens if the e-liquid is too cool and viscous), then the user experience is very poor.

Optional features of the PV (each of which can be combined with others) include the following:

- heating of the e-liquid begins when a case, such as a portable re-filling case, storing the device is opened to show the device.
- heating of the e-liquid can be done by secondary heating elements in the PV e-liquid chamber; these heating elements are not meant to heat the e-liquid to vapourising temperature, but to simply raise the e-liquids temperature so that the e-liquid transported by the wick to the heating elements that do heat to vapourising temperature is already pre-heated.
- heating of the substance to the temperature at which the device is ready for use can be predicted or inferred with sufficient accuracy because the charge level of the battery used to provide power to heat the substance is known reliably.
- the charge level is known reliably because a sensor directly measures that charge level.

- the charge level is known reliably because it can be assumed to be fully charged because the device is stored in a case that includes a battery that automatically charges the battery in the device.
- heating of the substance begins automatically when the device is removed from its case.
- heating of the substance begins when the device is slotted into or otherwise engaged with the case so as to securely engage, for extraction from the case, a new capsule including the substance to be vapourised.
- the indicator is a visual indication, or a sonic indicator, or a tactile indicator or a vibration indicator.

The following section describes these features with reference to the Figures; the relevant Figure is **Figure 73**. Referring to **Figure 73**:

A: As the vapouriser leaves the case electrical contact is broken with the case and the vapouriser automatically starts to heat the liquid (pre-heating)

B: Shows how the charge contacts between case and PV are broken as the PV is removed from the case

C: A light on the PV flashes or glows when the PV is ready to use, as shown schematically by the small circle with radial lines. The 'ready' indication could instead or in addition be a vibration or sound as well.

Pre-heating can also start when the case is simply opened and before the PV is withdrawn (the user may set (e.g. via a smartphone app) whether pre-heating starts at merely opening the case, or only when the PV is withdrawn from the case). Starting the heating process whilst the PV is still fully in the case enables the battery in the case to be used to provide power (typically by topping up the charge in the PV's internal battery as that internal battery provides the current to the atomizer). The detailed design of the working prototype, and fully described in **Section A** above (in particular **Figures 30** and **31** and the related description), also exemplifies the above features.

This document also describes (Feature 13) a single capsule dispenser, in which the PV uses a small capsule with e-liquid and that capsule is extracted from a dispenser by the user inserting the PV into the dispenser; a single capsule is then engaged onto the end of

the PV. In this variant, pre-heating of the e-liquid begins when the device is engaged into a case so as to securely engage a capsule including the substance to be vapourised; the PV includes the same kind of indicator to show that the PV is ready for use (e.g. the correct operating temperature has been reached); an alternative is that the PV pops out of the case when it is ready for use.

In each case, the temperature is not typically measured directly (although it may be); instead, that can be inferred from the current drain, resistance of the atomizer heating element, and any other relevant factor(s). Using the elapsed time of heating can be a simple and effective proxy for e-liquid temperature with this system, especially as the local battery in the PV will generally be fully charged or close to fully charged when heating starts, since it is continuously charged whilst the PV is stored in the case. Also, because the PV itself and the case can have knowledge of when the PV was last used and for how long, the remaining charge in the PV battery can be reliably inferred and the predicted time of heating can be automatically altered to compensate for varying levels of charge. In conventional PVs with a small rechargeable battery, time can generally not be used as a proxy because users do not reliably keep the battery close to fully charged.

Feature 9. PV with dosage indication

In this section, we describe the feature of an e-cigarette PV that indicates consumption of e-liquid using a visual indicator that extends or moves down the body of the PV away from the mouthpiece. The visual indicator moves or extends fully to indicate that a single dose has been consumed.

Optional features of the PV (each of which can be combined with others) include the following:

- the indication is visual, audible, touch feedback, haptic, vibration, heat or any other sensory signal.
- the indicator can be a visual indicator that extends or moves down towards the end of the device distant from the mouthpiece, and in which extending or moving from a start position to a final position corresponds to consuming or vapourising a single dose of the substance.
- the indicator can also include a visual indicator that extends or moves around the device, and in which extending or moving from a start position to a final position corresponds to consuming or vapourising a single dose of the substance.
- the indicator can provide a visual indication that alters to a specific colour when a single dose of the substance has been consumer or vapourised.
- the indicator can provide a haptic indication.
- the indicator can provide a heat-based indication.
- there is an additional indicator showing the charge level of a battery in the device.
- the or each indicator is implemented in a module that a user can connect in-between a conventional battery and any of: a conventional cartridge, atomizer or cartomiser.
- the module can screw into the conventional battery and the conventional cartridge, atomizer or cartomiser.
- the PV also can include a humidity sensor capable of monitoring humidity changes and is capable of evaluating how much vapour the device is producing.
 - the humidity sensor is positioned at the mouth of a cartomisor.

- the humidity sensor is implemented in a module that a user can connect in-between a conventional battery and any of the following: conventional cartridge, atomizer or cartomiser.
- the humidity sensor is implemented in a battery pack component, or a cartomiser, or an atomizer, or a mouthpiece.
- the PV configured to use humidity data for dosage control.
- the PV is configured to transmit humidity data to a case, a connected smartphone or directly to a computing device.
- the PV can be designed to engage with a portable re-filling storage and carrying case that includes a reservoir for the e-liquid from which the personal vapouriser can be refilled, and in which the vapouriser can only, in normal use, be refilled when slotted into or otherwise engaged with the portable case and that case is operable to re-fill the personal vapouriser so that the personal vapouriser has a single dose of the substance to be vapourised.
- the PV can be designed to engage with a portable unit for storing the portable vapourising device, in which the unit is programmed to prevent release of the device for predetermined amounts of time as an aid to cessation or reduction of substance usage.
 - time is indicated through colour lights or a countdown timer.

This feature also encompasses a personal vapourising device including a humidity sensor capable of monitoring humidity changes and therefore capable of evaluating how much vapour the device is producing.

Optional features of the PV (each of which can be combined with others) include the following:

- the humidity sensor is implemented in a module that a user can connect in-between a conventional battery and any of the following: a conventional cartridge, atomizer or cartomiser.
- the humidity sensor is implemented in a battery pack component, or a cartomiser, or an atomizer, or a mouthpiece.
- the PV is configured to use humidity data for dosage control.

- the PV is configured to transmit humidity data to a case, a connected smartphone or directly to a computing device.

This feature also encompasses a portable unit for storing a portable vapourising device, in which the unit is programmed to prevent release of a personal vapouriser device for predetermined amounts of time as an aid to cessation or reduction of substance usage. Time may be indicated through coloured lights or a countdown timer on the portable unit, or via data transmitted to a secondary device that could display this information.

The following section describes these features with reference to the Figures; the relevant Figures are **Figure 2**, and **Figures 74 - 75**.

An example of vapouriser including an indication of how much substance has been vapourised is shown in **Figure 74**, in which the quantity of vapour inhaled is inferred using a pressure sensor that senses when a user inhales (and optionally the strength of the inhalation or the volume inhaled), plus a time sensor that measure for how long an inhalation lasts.

There are various ways to indicate when a single or end-user set dose of the e-liquid has been consumed or vapourised.

A: A light moves down the vapouriser as if it is 'burning down'. A similar visual indicator is shown in **Figure 2**; a series of twelve LEDs progressively light up as the PV consumes nicotine equivalent to a single cigarette – typically one LED lights up per inhalation, where the e-liquid strength used means that twelve inhalations corresponds to smoking a single cigarette. The user can also set the LEDs so that a single LED lights up when nicotine equivalent to an entire cigarette is consumed. Hence, the Figure 2 device would show when the equivalent of between one and twelve entire cigarettes had been consumed.

B: Single light changes colour to show how much has been inhaled. A traffic light system (green, amber, red) or change in brightness of light (dimming with usage) could be used and when the light shows red or is fully dimmed out it means that the dose has been

provided; the PV may at this time stop working for a set period if the user is on a nicotine or smoking cessation or reduction programme.

C: the light, at one end of, or anywhere on the PV, changes colour, as above.

A conventional PV can be adapted to use this feature: **Figure 75** shows a conventional two part PV, with an e-liquid cartridge above the atomizer and the atomiser above the battery, but by adding a third module between the standard cartridge/atomizer/cartomiser and the battery where the additional new module includes an indicator that alters to indicate when a single or end-user set dose of the substance has been consumed or vapourised, as described above. Many conventional PVs use standard sizes, so this approach enables a conventional PV to be upgraded to one that is far more useful in a smoking or nicotine cessation or reduction program.

Figure 76 is another approach to dosage control: the PV case is programmed to prevent release of the PV for predetermined amounts of time as an aid to cessation or reduction of substance usage, tamper prevention, preventing children accessing the PV etc. The case itself may indicate that a single dose, including an end-user set dose, of the substance has been consumed or vapourised in the PV it is storing. The case can be programmed or controlled (e.g. from the user's smartphone) not to power up for a specified period of time, at certain times, or at a certain frequency or duration; these could all be variable and adjusted by the smartphone app.

Figure 77 shows the humidity sensor variants as described above.

Feature 10. PV Drip prevention

In this section, we describe several drip-prevention features in the PV.

The first feature is a PV includes a tip that includes (a) an e-liquid filling aperture that is designed to engage an e-liquid transfer mechanism, the aperture being centrally positioned along the long axis of the PV, the aperture being connected to an e-liquid storage chamber in the PV; (b) one or more vapour outlets distributed around the e-liquid filling aperture; and in which the vapour outlets are connected by passages to a vapour chamber including a vaporising element, and the vapour chamber is sealed from the e-liquid storage chamber.

The second feature is a PV with e-liquid leak suppression where an e-liquid filling aperture in the PV is adapted to align, when inserted into a re-filling unit, with a hollow tube that is part of a fluid transfer system in the re-filling unit, and the aperture includes a flexible seal through which the tube is inserted or passes, the seal ensuring that any drips of e-liquid are retained within the PV when the PV is withdrawn from or removed from the re-filling unit.

The third feature is a PV with e-liquid leak suppression where the vapour passage is not a straight through path from the atomiser but instead includes at least one turn and terminates in one or more vapour outlets distributed around an e-liquid ingestion nozzle positioned centrally along the long axis of the PV.

Optional features of the PV (each of which can be combined with others) include the following:

- the presence of the barriers causes the length of the passage to be substantially longer than if there were no barriers.
- the barriers ensure that the passage is not a straight path.
- the barriers cause the width of the passage to be constricted compared to the width the passage would have if there were no barriers.
- the barriers comprise a double cap.

- the barriers make the passage a serpentine path.
- the passage is lined with an absorbent material to absorb any droplets that escape from the unit, without impeding the flow of vapour through the passage.

These features also encompass a personal vapouriser comprising a unit storing a substance to be vapourised, an atomizer and a passage connecting the atomizer to a mouthpiece through which vapour may be drawn by a user, wherein the passage is lined with an absorbent material to absorb any droplets that escape from the unit, without impeding the flow of vapour through the passage.

The detailed design of the working prototype, fully described in **Section A** above, also exemplifies the above first and second features.

The following section further describes these features with reference to the Figures; the relevant Figures are **Figures 80 – 84**.

Figure 80A shows a second barrier in the mouthpiece that does not significantly impede vapour flow but provides a harder, tortuous path (the dark arrow) for e-liquid droplets to follow. A solid tube around the e-liquid store has been added to stop droplets of e-liquid being squeezed out (conventional PVs may have a flexible tube that can be squeezed). a Soft flexible skin around the solid tube can be provided for better tactility.

Figure 80B shows a variant in which the vapour path is not tortuous as in **Figure 80A**, but instead a double cap is provided in the mouthpiece, making it much less likely that e-liquid droplets will escape.

Figure 80C shows a further variant in which a series of fins in the mouthpiece makes it much less likely that e-liquid droplets will escape.

Figure 81 shows a seal being placed over the end of the e-liquid saturated cloth; by capping the saturated cloth in this way with a consistent and effective seal, it makes it much harder for e-liquid droplets to migrate into the inhalation track. In **Figure 81**, this is combined with an elongated cap, again reducing the possibility that any droplets of e-liquid will leak out.

Figure 82 shows adding a seal to the end of the e-liquid saturated cloth, but also adding a dry cloth or foam insert to absorb any droplets that do escape, and to prevent vapour build up. If any small droplets do adhere to the side of the internal cap, then the return shape of the internal cap leads them away from the inhalation tip.

The choice of absorbent material is important: Hydrophilic absorbent material that absorbs water and water based liquids is effective. The material is in a compact tube form to fit into the small space in an inhalator end, and it swells by absorbing rapidly a liquid such as water or liquidised nicotine based gel. Types of material include but are not limited to:

- Synthetic sponge
- Synthetic Chamois
- Microfiber synthetic cloth
- Hydrogel (Hydrogels are highly absorbent (they can contain over 90% water) natural or synthetic polymeric networks)

Absorption materials should not absorb moisture in vapour suspension as this would harm inhalation, only liquids that are free moving in the vapouriser case are absorbed. The hydrophilic material could also be changed periodically to ensure the vapouriser performance is not reduced.

Figure 83 shows the approach of moving the e-liquid reservoir to the end furthest from the mouthpiece – this provides a much longer path for any e-liquid droplets to flow before reaching the mouthpiece. It also balances the cigarette more naturally and provides a better vaping/vapour experience.

Figure 84 shows containing the e-liquid in a sealed container to stop droplet migration. The wick will leave the container via a tight hole and use capillary action to retain a wet coating. It is highly unlikely that the wick will itself permit the migration of droplets of e-liquid that could then leak out from the mouthpiece.

Section C: User-replaceable e-liquid cartridge

Whereas **Section A** focused on the storing and carry case, and **Section B** focused on the PV, in this **Section C** we describe the features of the user-replaceable e-liquid cartridge.

Following the consecutive numbering in earlier sections:

Feature 11. User-replaceable e-liquid cartridge

A first feature is a user-replaceable e-liquid cartridge adapted to be inserted into or attached to portable, personal storage and carrying case for an e-liquid e-cigarette PV. **Figure 5** shows the cartridge 3 and the **Section A** description of the working prototype that uses this cartridge. **Figure 6** shows a different design of cartridge 3 withdrawn from case 100. **Figure 7** shows cartridge 3 fully inserted into case 100.

A complimentary feature a portable, personal storage and carrying case for an e-liquid e-cigarette PV in which the case includes a user-removable e-liquid cartridge.

Key subsidiary features:

- e-liquid cartridge has a casing that is adapted to be fitted by a user into a chamber in a portable, personal storage and carrying case for an e-liquid e-cigarette PV.
- cartridge has an outer surface that forms part of the casing of the case (with this variant, the cartridge is still ‘in the case’, and the case still ‘includes the cartridge’ as those phrases are used in this specification)
- cartridge attaches to the case – e.g. the cartridge forms an extension to the case; with case and cartridge when combined forming a unitary object (with this variant, the cartridge is still ‘in the case’, and the case still ‘includes the cartridge’ as those phrases are used in this specification)
- e-liquid cartridge is not substantially deformable in normal use in order to displace fluid from the cartridge
- e-liquid cartridge is made using PET
- e-liquid cartridge is designed to slot inside a portable, personal storage and carrying case for an e-liquid e-cigarette PV with a press fit against a seal and in which the cartridge is formed with a void designed to receive and engage with a

micro-pump that is positioned in the case, the micro-pump sealing against a nozzle in the cartridge.

- e-liquid cartridge is designed to slot inside a portable, personal storage and carrying case for an e-liquid e-cigarette PV with a press fit against a seal and in which the cartridge includes an integral micro-pump
- case includes a user-replaceable cartridge with several compartments and can fill the PV by combining e-liquid from several compartments
- case includes several user-removable e-liquid cartridges and can fill the PV by combining e-liquid from several cartridges
- case and/or cartridge includes an overflow channel that enables excess e-liquid that is pumped up from the cartridge but is not stored in the PV to be captured and returned to the cartridge
- cartridge screws into the case
- cartridge includes electronic identifier, such as RFID chip.
- Cartridge includes physical features on its surface, such as raised or lowered portions, that physically engage with complimentary features in the wall of the case aperture into which the cartridge is inserted.
- The physical features form the shape of a word or logo, such as a trademarked word or logo

In this section, we describe in more detail the feature of the re-filling unit including multiple user-replaceable cartridges/chambers: A portable unit for re-filling a reservoir in a portable vapourising device, the unit including multiple user-replaceable cartridges or chambers, each containing a substance to be vapourised, in which the unit enables the portable vapourising device to be filled with one specific substance, or a predetermined mixture of two or more substances.

Optional features (each of which can be combined with others) include the following:

- a user may specify which substance is used to refill the PV.
- a user may specify refilling the substance(s) to create a custom mixture.
- a customised mixture may be in accordance with a smoking or nicotine cessation

or reduction program.

Combining the multi cartridge/chamber approach with the features of the Feature 5 'Intelligent case' leads to many useful and novel features: for example, the case can learn which flavours/strengths of e-liquid the user prefers, possibly as a function of time of day, location, day of the week, time of the day. Like a good personal assistant, the case can then prepare in advance the right flavour/strength given these factors or even suggest that it does so to the user (e.g. a message could appear on the user's smartphone app that exchanges data with the PV and/or case). The case and/or related smartphone app (or any other kind of connected electronic device, such as wearable glasses, a smartwatch etc) also recommend new flavour(s) or other things that the user may like, in much the same way as an online music service.

The following section describes these features with reference to the Figures; the relevant Figures are **Figures 71** and **72**.

An example of a portable charging and re-filling case equipped with four separate cartridges (numbered 1, 2, 3 and 4) is shown in **Figure 71A**. Four cartridges have been used for illustrative purposes, but this could be more or less.

Figure 71B shows the four cartridges loaded into a carriage; each cartridge will typically have a different strength or type of e-liquid. For example, if the user following a smoking or nicotine cessation or reduction program, each cartridge could have a different strength of nicotine; one cartridge could be a placebo or a vitamin/mineral e-liquid or just the standard propylene glycol base. Another approach could be to have e-liquids of similar nicotine strength, but with different flavours. It would also be possible to have different flavours of totally nicotine-free e-liquid – this might be especially useful to someone who has successfully completed a nicotine cessation program. Each cartridge is individually user replaceable (but not in normal use refillable, although this is one possible variant).

The carriage has small valves (not shown) used to permit or prevent e-liquid flowing from each cartridge through to the refilling mechanism, under the control of the software and processor in the unit (which may in turn be under the control of the user's smartphone or other device – typically, the user would enter the desired mix into an app

running on a smartphone, and the smartphone would then send the appropriate control data to the processor in the unit; the smartphone can be replaced by any other suitable type of computing device, including wearable computing devices receiving touch based and/or spoken commands). The unit may also include a touch screen that enables the user to enter the desired mix directly into the unit. Mixing of the e-liquids can occur in the carriage itself, or in a separate chamber on leaving the cartridge.

Figure 71C shows a single cartridge with four chambers; the cartridge includes the valves (each shown schematically as circle with a line) that enable different chambers to be opened or closed as appropriate under the control of the software and the processor (again, usually, implementing instruction received from the user's smartphone). Mixing of the e-liquids can occur in the cartridge itself, or in a separate chamber on leaving the cartridge. The whole cartridge is user replaceable (but not in normal use refillable, although this is one possible variant).

Figure 72 shows how the user's smartphone can display the current levels of e-liquid in each cartridge:

In Step A, the electronics in the case record the level of the cartridges.

In Step B, when the vapouriser is inserted into the case it transfers its usage data to the electronics in the case.

In Step C, the case gives a visual indication when at least one cartridge level is low. This can take into account current levels in the cartridge(s), and also predicted future levels taking into account the rate of consumption by the user and how much e-liquid is left in the PV itself.

In Step D, the case sends data to a connected smartphone device to inform of the low cartridge level. The case may take into account how much e-liquid is left in or has been consumed by the vapouriser, and the rate at which it has been consumed in the past, when determining whether to alert the user or order replacement cartridges.

The smartphone can display a message such as 'Order replacement Cartridge 2, which is nicotine strength xx?', or "We predict that you will run out of e-liquid nicotine strength xx at your current consumption rate in 4 days, shall we re-order?' together with a 'Buy Now' option. If the user selects the 'Buy Now' option, then a message is sent over the

internet to an e-fulfillment provider, who then sends out the replacement cartridge to the user, who then installs it into the case.

The above 'Multi-liquid' cartridge can be controlled by an electro-mechanical valve system that regulates the volume of liquid flowing through the valve, whereby moving a pin controls the flow and quantity of liquid into an anti-chamber, in turn creating a defined mixture which is then injected into the vapouriser by either a non-pressurised or pressurised pump system. This could be electronically controlled to mix a predefined volume and mixture of liquids. Examples being

- Predefined smoking cessation program to reduce down the nicotine levels over a period of time.
- To mix several liquids to make unique flavours.
- Move from Menthol inhaling to straight nicotine based inhaling liquid.
- Cartridge Lock-out for child protection

Miscellaneous Features

Feature 12. Hygienic PV

In this section, we introduce the feature of the PV including a hygienic mouthpiece: A personal vapourising device including a housing and a mouthpiece, in which the mouthpiece is extendable from and retractable within a body of the device.

Optional features of the PV (each of which can be combined with others) include the following:

- the mouthpiece is made of a soft touch material.
- the mouthpiece is extended from the housing when the tip of the device at the end opposite to the mouthpiece is depressed by the user.
- extending the mouthpiece causes the device to automatically start heating the substance to be vapourised.
- a second depression by the user causes the mouthpiece to retract within the body of the device.

The following section describes these features with reference to the Figures; the relevant Figures are **Figures 85** and **86**. **Figure 85** shows a PV with an outer sleeve through which the mouthpiece/atomizer and battery parts of the PV can slide. **Figure 85A** shows a schematic external view, with the mouthpiece or inhalation tip fully extended; **Figure 85B** is a cross sectional view of **Figure 85A**, showing the mouthpiece/atomizer and battery parts. In **Figure 85C**, the inhalation tip is fully retracted within the sleeve; as a consequence, the battery end of the PV is now protruding out of the sleeve. **Figure 85D** shows the internal parts of the **Figure 85C** view. When the inhalation tip is fully retracted, the user can click on the other end to cause the inhalation tip to pop out; clicking it again can cause the tip to retract, in much the same way as clicking the top of a ballpoint pen. Clicking the end to cause the inhalation tip to pop out can also be used to turn the PV on to start heating.

Figure 86 shows the same four views, but this time with a different design of PV (described more fully as Feature 14). In this different design, a single dose capsule is secured at the end of the PV furthest from the inhalation tip; pushing the soft-tip inhalation into the sleeve/housing causes the capsule to be ejected.

Feature 13. Single Capsule Dispenser

In this section, we introduce the feature of a dispenser storing multiple capsules, each containing a substance to be vapourised, wherein the dispenser enables a personal vapourising device to be inserted into the dispenser to securely engage a capsule.

Optional features of the capsule dispenser (each of which can be combined with others) include the following:

- a stack of capsules is inserted into the dispenser and a spring urges the stack up inside the dispenser.
- the spring may be any other type of device for applying a force.
- a capsule is designed to securely engage with the vapourising device when the device is pressed against the capsule.
- a single capsule includes substance equivalent to a single [combustible] cigarette.
- a single capsule includes an amount of substance designed for a nicotine or smoking cessation or reduction program.
- a single capsule can be any of the following: nicotine, caffeine, vitamin, mineral, flavoured substance, or any mixture of any of these.
- different capsules can be selected by the user to be different strengths of nicotine.
- different capsules can be selected by the user to be different flavours of nicotine.
- different capsules can be selected by the user to be different types of vapourisable substance.

The following section describes these features with reference to the Figures; the relevant Figure is **Figure 87**.

Figure 87A: A stack of capsules is inserted into the dispenser and a spring (or any other type of device for applying a force) urges the stack up inside the dispenser.

Figure 87B and 87C: A capsule is designed to securely engage (e.g. a press fit) with the PV device when the PV device is inserted down into the case and pressed against the capsule. The capsule engages with the end furthest from the inhalation tip/mouthpiece. The PV can be withdrawn from the case, with the capsule securely attached. A single

capsule typically includes e-liquid equivalent to a single cigarette. A single capsule may also include an amount of substance designed for a cigarette or nicotine cessation or reduction program – hence the stack of capsules shown in **Figure 87A** may have progressively less nicotine.

Feature 14. Single Capsule PV

In this section, we introduce the feature of a PV with an ejectable single-dose capsule: A personal vapouriser device including a capsule containing substance to be vapourised at one end of a housing furthest from the mouthpiece and where the capsule is ejected by the user pressing a component in the device.

Optional features of the PV (each of which can be combined with others) include the following:

- the component pressed by the user is a button.
- the component pressed by the user is a mouthpiece and in which the mouthpiece is slid out from and retracted back into the housing, the mouthpiece retracting causing the capsule to eject.
- a single capsule includes an amount of substance equivalent to a single cigarette.
- a single capsule includes an amount of substance of a predetermined amount as decided or selected by the user.
- a single capsule includes an amount of substance designed for a cigarette or nicotine cessation program.
- the PV is designed to engage with a dispenser storing multiple capsules, each containing a substance to be vapourised, wherein the vapourising device is inserted in normal use into the dispenser to securely engage a capsule.

This feature encompasses also a personal vapouriser comprising a unit storing a substance to be vapourised, and a mouthpiece at one end, in which the reservoir storing the substance to be vapourised is placed towards the end furthest from the mouthpiece.

Optional features of the PV (each of which can be combined with others) include the following:

- the unit is a capsule that encapsulates the substance.
- the unit is a conventional e-cigarette cartridge.
- unit is pressed on to the end of the vapouriser and securely engages with the vapouriser.

The following section describes these features with reference to the Figures; the relevant Figures are **Figures 83** and **86**.

Figure 83 shows moving the e-liquid chamber to the end furthest from the mouthpiece; in this case, the entire cartomiser is moved to the end furthest from the mouthpiece. This balances the PV more naturally and so provides a better experience.

Figure 86 shows a single dose capsule is secured at the end of the PV furthest from the inhalation tip; pushing the soft-tip inhalation into the sleeve/housing causes the capsule to be ejected.

Feature 15. Various Constructional Improvements

This section describes a broad range of constructional improvements; the relevant Figures are **Figure 89 to 94**

Figure 89 shows an e-liquid capsule (typically with a single dose of nicotine, e.g. equivalent to a single cigarette, or a pack of 5 cigarettes). The capsule is inserted by the user into the heating atomizer and then places the mouthpiece over the capsule; a piercing point forms a small puncture in the top of the capsule, enabling heated vapour to be drawn through the mouthpiece. This design allows user to know how much they are 'vaping' and is also a much cheaper and easier to use refill approach, compared with conventional approaches.

Figure 90 shows a spiraled, acid etched element being used as the heating element; the acid etching increases the effective surface area of the heating element; rolling the element up in a spiral around a saturated mat allows a much larger element than is normal, again giving faster and more efficient vapour production and also inhibits the saturated mat from releasing droplets of e-liquid.

Figure 91 shows wrapping an acid etched heating element around the outside of an e-liquid saturated core; this approach provides a large heating area, but is simpler than the spiral arrangement of Figure 111. A second barrier prevents droplet leakage.

Figure 92 shows a large wick, made of compressed fibres like a marker pen's nib, inserted into and drawing e-liquid from a container; the sides of the wick that are external to the e-liquid container are in contact with an acid-etched heating element; the effectiveness of the wick in drawing up e-liquid provide a consistent vapour.

Figure 93 shows using a pair of piezo transducers that generate ultrasonic waves to produce the e-liquid vapour; the e-liquid is in a sealed chamber with a water tight valve that can release vapour but not droplets.

Figure 94 shows using a chemical heat source to heat the e-liquid; a combination of chemicals are encapsulated together with an e-liquid container; when the capsule is

pushed against a piercing pin at one end of a sleeve, mixing of the chemicals generates enough heat to create a vapour, which the user sucks through the mouthpiece. Enough heat could be provided to vapourise a single dose. This design eliminates the need for batteries or control electronics. It would be cheap to manufacture.

APPENDIX 1: CONSOLIDATED CONCEPTS SUMMARY

This section summarises the most important high-level features described above; an implementation of the invention may include one or more of these high-level features, or one or more of the key subsidiary features, or any combination of any of these.

As before, we will organise this summary into three sections:

Section A. E-Liquid Re-filling and Re-Charging Storing and Carrying Case

- | | |
|------------|--|
| Feature 1. | Combined re-charge and re-fill storage and carrying case |
| Feature 2. | Case with movable PV holder |
| Feature 3. | Re-Filling the PV |
| Feature 4. | PV Locking mechanism |
| Feature 5. | Data connectivity |
| Feature 6. | E-fulfilment |

Section B. PV: Simplicity and ease of use

- | | |
|-------------|----------------------------------|
| Feature 7. | Re-fillable and re-chargeable PV |
| Feature 8. | PV with pre-heat |
| Feature 9. | PV with dosage indication |
| Feature 10. | PV with drip prevention |

Section C. User-replaceable e-liquid cartridge

- | | |
|-------------|---|
| Feature 11. | User-replaceable e-liquid cartridge that fits into the portable storage and carrying case |
|-------------|---|

We will start with **Section A.** To facilitate mapping of these features to future patent claims, we will label the features as ‘concepts’ and number them in a claim-like manner. Any singly dependent concept (e.g ‘the concept of Claim 1) should be construed as also

covering all multiple dependencies (e.g. is equivalent to 'the concept of any preceding concept). Note also that any concept relating to any feature can be combined with any other concept attributed to any feature.

Section A: E-Liquid Re-filling and Re-Charging Storing and Carrying Case

Feature 1.	Combined re-charge and re-fill storage and carrying case
Feature 2.	Case with movable PV holder
Feature 3.	Re-Filling the PV
Feature 4.	PV Locking mechanism
Feature 5.	Data connectivity
Feature 6.	E-fulfilment

Feature 1. Combined re-charge and re-fill PV storage and carrying case

1. A portable, personal storage and carrying case for an e-liquid e-cigarette PV in which the case includes: (a) a power source for re-charging a rechargeable battery in the PV; (b) a reservoir for holding e-liquid; and (c) a fluid transfer system adapted to transfer e-liquid from the reservoir to a chamber in the PV.
2. The case of Concept 1 in which the reservoir for holding e-liquid is a user-replaceable e-liquid cartridge.
3. The case of Concept 2 in which the user-replaceable e-liquid cartridge fits in the case or is attached to the case
4. The case of Concept 2 in which the user-replaceable e-liquid cartridge is designed in normal use to permit e-liquid to escape only if the cartridge is correctly positioned in the case
5. The case of Concept 2 in which the e-liquid capacity of the user replaceable cartridge is at least three times, and preferably five times, greater than the e-liquid capacity of the chamber in the PV

6. The case of Concept 1 in which the fluid transfer system adapted to transfer e-liquid from the case to a reservoir in the PV includes a pump that delivers e-liquid approximately equivalent to a single cigarette for each pumping stroke
7. The case of Concept 1 in which the case includes one or more re-chargeable batteries or one or more user-replaceable batteries, and electrical contacts designed to securely engage with contacts in the PV, for example when the PV is stored in the case.
8. The case of Concept 1 in which the overall size and shape of the case allows it to be kept in a normal pocket.
9. The case of Concept 1 which can be locked or disabled to prevent under-age or unauthorised use.
10. The case of Concept 9 which can be locked or disabled to prevent under-age or unauthorised use and can be unlocked using data sent or exchanged with the authorised user's smartphone
11. The case of Concept 1 in which the case includes a user-removable e-liquid cartridge and the combination of cartridge and case forms in normal use a portable, personal device for the storage, carrying of the PV and its re-filling with e-liquid.
12. The case of Concept 1 which starts providing power to heat an electrical atomising element in a PV automatically when the case in which the PV is stored is opened.
13. The case of Concept 1 which also shows when the PV is ready for use because heating to an operational level has been reached or heating for a predefined time has occurred.
14. The case of Concept 1 in which the case can fill the PV by combining e-liquid from several different e-liquid compartments
15. The case of Concept 1 in which the case includes several user-removable e-liquid

cartridges and can fill the PV by combining e-liquid from several cartridges

16. The case of Concept 1 in which the case includes an overflow channel that enables excess e-liquid that is pumped up from the cartridge but is not stored in the PV to be captured and returned to the cartridge.

17. The case of Concept 1 in which the user-replaceable cartridge includes physical features on its surface, such as raised or lowered portions, that physically engage with complimentary features in the wall of the case aperture into which the cartridge is inserted.

18. The case of Concept 17 in which the physical features form the shape of a word or logo, such as a trademarked word or logo.

19. The case of Concept 1 in which moving a movable holder or chassis, into which the PV has been inserted, brings electrical charging contacts on the PV into direct or indirect engagement with electrical charging contacts in the case that are connected to a power source in the case.

20. The case of Concept 1 which is operable to re-fill the PV with e-liquid if the PV is inserted, fully or in part, into the case, whilst maintaining the PV whole and intact.

21. The case of Concept 1 which is adapted to lock the PV securely in a charging position; and when the PV is locked in the charging position, then electrical charging contacts on the PV are in direct or indirect engagement with electrical charging contacts in the case that are connected to a power source in the case.

22. The case of Concept 1 which includes (a) user-replaceable e-liquid cartridge; and (b) a fluid transfer system adapted to transfer e-liquid from the cartridge to a chamber in the PV; in which the case includes a data processor that controls sending a signal requesting a replacement for a user-replaceable e-liquid cartridge in the case.

23. The case of Concept 1 in which the e-liquid includes nicotine and the PV is not a medicinal device but instead a device that in normal use replaces cigarettes, with the e-

liquid being vapourised in the PV and the vapour inhaled to replicate the experience of smoking a cigarette.

24. A portable, personal storage and carrying case for an e-liquid e-cigarette PV in which the case is adapted to transfer e-liquid to an e-cigarette PV from a user-replaceable e-liquid cartridge in or attached to the case.

Feature 2. Case with movable PV holder feature

1. The case of Concept 1 in which moving a movable holder or chassis, into which the PV has been inserted, brings electrical charging contacts on the PV into direct or indirect engagement with electrical charging contacts in the case that are connected to a power source in the case.

2. The case of Concept 1 in which the movable chassis also has mounted on it an e-fluid reservoir, a battery, a printed circuit board and a fluid transfer mechanism

3. The case of Concept 1 in which the holder pivots about a screw or other form of axis in the case

4. The case of Concept 3 in which the holder is formed as a trigger, so that a user closing his grip on one part of the holder causes the hinged folder to open from the case, enabling a PV stored in the case to be withdrawn from the case.

5. The case of Concept 1 in which the holder includes a channel into which the PV can slide, the channel guiding the PV into the position needed for accurate re-filling with e-liquid

6. The case of Concept 5 in which the channel enables the PV to be moved up and down relative to a pump, acting as the stroke which causes the pump to transfer e-liquid from a reservoir in the case to a chamber in the PV.

7. The case of Concept 1 in which the holder is a hinged compartment that the PV is slotted into, mouthpiece end downwards, and which guides an aperture of the PV into contact with a pump nozzle that fills a chamber in the PV with e-liquid until the pressure in the chamber equals the pressure in an e-liquid cartridge in the case.
8. The case of Concept 1 in which the PV includes an e-liquid filling aperture or nozzle positioned centrally along the main axis of the PV to minimise any off-centre forces that could otherwise compromise e-liquid sealing and the holder guides that e-filling aperture or nozzle into accurate alignment with a fluid transfer mechanism.
9. The case of Concept 1 in which the holder is a hinged compartment that the PV is slotted into, mouthpiece end downwards, and which, whenever the hinged compartment is closed, cams the PV downwards to prime or activate a pump nozzle that will deliver e-liquid from a cartridge into a chamber in the PV until the pressure in the chamber equals the pressure in an e-liquid cartridge in the case.
10. The case of Concept 1 in which the holder has to be fully closed to bring the electrical charging contacts on the PV into direct or indirect engagement with electrical charging contacts in the case.
11. The case of Concept 1 in which the movable holder has to be partly closed to bring the electrical charging contacts on the PV into direct or indirect engagement with electrical charging contacts in the case.
12. The case of Concept 1 which is operable to re-fill the PV using a fluid transfer system pump activated by moving relative to the pump the entire, complete PV, whilst the PV is held in the holder.
13. The case of Concept 1 in which the holder is a side-loading holder.
14. The case of Concept 1 in which the holder is manually moved.
15. The case of Concept 1 in which the holder is moved using one or more motors.

16. The case of Concept 1 in which the e-liquid includes nicotine and the PV is not a medicinal device but instead a device that in normal use replaces cigarettes, with the e-liquid being vapourised in the PV and the vapour inhaled to replicate or replace the experience of smoking a cigarette.

Feature 3: Re-Filling the PV

1. A portable, personal storage and carrying case for an e-liquid e-cigarette PV which is operable to re-fill the PV with e-liquid if the PV is inserted, fully or in part, into the case, whilst maintaining the PV whole and intact.

2. The case of Concept 1 which is adapted to transfer e-liquid to an e-cigarette PV from a user-replaceable e-liquid cartridge in or attached to the case.

3. The case of Concept 1 which re-fills the PV using a fluid transfer system, whilst the PV is held in a holder of the case in accurate alignment with the fluid transfer mechanism.

4. The case of Concept 1 in which the fluid transfer system is a pump activated by moving the entire, complete PV relative to the pump.

5. The case of Concept 1 in which is operable to re-fill the PV with e-liquid if the PV is inserted, fully or in part, into the case without the need to dis-assemble or puncture the PV.

6. The case of Concept 1 which is operable to re-fill and re-charge the PV, without the need to dis-assemble or puncture the PV, via an e-liquid filling aperture or nozzle formed in one end of the mouthpiece, the e-liquid filling nozzle being separate from the vapour inhalation nozzle(s).

7. The case of Concept 1 in which the PV includes an e-liquid filling aperture or nozzle positioned centrally along the main axis of the PV to minimise any off-centre forces that could otherwise compromise e-liquid and the case guides that aperture or

nozzle into accurate alignment with a fluid transfer mechanism.

8. The case of Concept 7 in which the aperture or nozzle aligns with a hollow tube or shaft that is part of a pump and the aperture or nozzle includes a flexible seal through which the tube or shaft is inserted, the seal ensuring that any drips of e-liquid are retained within the PV.

9. The case of Concept 7 in which a tip of the PV includes a fluid trap and absorbent wicking to capture any fluid leakage.

10. The case of Concept 1 in which a hollow e-liquid filling tube or shaft extends up from the central axis of a pump against which the PV is positioned.

11. The case of Concept 1 in which the PV re-fills using a pump activated by depressing and releasing the entire, complete PV whilst the PV is held in a hinged compartment of the case and the PV can slide up and down in the compartment.

12. The case of Concept 1 in which the PV is re-filled by a mechanical camming action caused by the top of the PV being pressed or cammed downwards when it is closed inside a carrying case, the camming action depressing the PV so that it completes a downstroke of the pumping action

13. The case of Concept 1 in which the case includes a hinged compartment that the PV is slotted into, mouthpiece end downwards, and which guides an aperture of the PV into contact with a pump nozzle that fills a chamber in the PV with e-liquid until the pressure in the chamber equals the pressure in an e-liquid cartridge in the case.

14. The case of Concept 1 in which the case automatically re-fills and re-charges an e-cigarette PV, the case including a hinged compartment that the PV is slotted into, mouthpiece end downwards, and which, whenever the hinged compartment is closed, cams the PV downwards to prime or activate a pump nozzle that will deliver e-liquid from a cartridge into a chamber in the PV until the pressure in the chamber equals the pressure in an e-liquid cartridge in the case.

15. The case of Concept 1 in which the case includes a micro-pump designed to slot into or be received by an aperture in an e-liquid cartridge.
16. The case of Concept 2 in which the case includes a nozzle or aperture operable to engage with a micro-pump formed in the e-liquid cartridge inserted into or attached to the case.
17. The case of Concept 1 in which the case includes a user-removable e-liquid cartridge and the combination of cartridge and case forms in normal use a portable, personal device for the storage, carrying of the PV and its re-filling with e-liquid.
18. The case of Concept 1 in which the case can fill the PV by combining e-liquid from several different e-liquid compartments.
19. The case of Concept 1 in which the case includes several user-removable e-liquid cartridges and can fill the PV by combining e-liquid from several cartridges.
20. The case of Concept 1 in which the case includes an overflow channel that enables excess e-liquid that is pumped up from the cartridge but is not stored in the PV to be captured and returned to the cartridge.
21. The case of Concept 1 in which the user-replaceable cartridge includes physical features on its surface, such as raised or lowered portions, that physically engage with complimentary features in the wall of the case aperture into which the cartridge is inserted.
22. The case of Concept 21 in which the physical features form the shape of a word or logo, such as a trademarked word or logo.
23. The case of Concept 1 in which if the PV is pumped just once, then the case transfers e-liquid approximately equivalent to a single cigarette to the PV and if the PV is pumped five times then the case transfers e-liquid approximately equivalent to five cigarettes.

24. The case of Concept 1 in which the e-liquid includes nicotine and the PV is not a medicinal device but instead a device that in normal use replaces cigarettes, with the e-liquid being vapourised in the PV and the vapour inhaled to replicate or replace the experience of smoking a cigarette.

25. A portable, personal storage and carrying case for an e-liquid e-cigarette PV in which the case is adapted to transfer e-liquid to an e-cigarette PV from a user-replaceable e-liquid cartridge in the case.

26. A portable, personal storage and carrying case for an e-liquid e-cigarette PV which re-fills the PV using a fluid transfer system, such as a pump activated by moving relative to the pump the entire, complete PV, whilst the PV is held in a holder of the case in accurate alignment with the fluid transfer mechanism.

Feature 4: PV locking mechanism

1. A portable, personal storage and carrying case for an e-liquid e-cigarette PV in which the case is adapted to lock the PV securely in a charging position; and when the PV is locked in the charging position, then electrical charging contacts on the PV are in direct or indirect engagement with electrical charging contacts in the case that are connected to a power source, such as a rechargeable battery, in the case.

2. The case of Concept 1 in which the case automatically charges the PV only if the PV is fully inserted and an inter-lock operates to secure the PV in position.

3. The case of Concept 1 in which the case automatically locks the e-cigarette PV into a secured re-charging position when the case is fully closed for storage and carrying the PV.

4. The case of Concept 1 in which electrical charging contacts in the case are positioned on a sliding contact block that moves from a first position in which it is not physically engaged with the PV and a second position in which it is itself locked in position and also secures the PV in position.

5. The case of Concept 1 in which the sliding contact block also includes data transfer contacts that engage directly or indirectly with data transfer contacts in the PV.
6. The case of Concept 1 in which the electrical charging contacts inductively transfer power from the case to the PV.
7. The case of Concept 1 which can be locked or disabled to prevent under-age or unauthorised use.
8. The case of Concept 7 which can be locked or disabled to prevent under-age or unauthorised use and can be unlocked using data sent or exchanged with the authorised user's smartphone.
9. The case of Concept 1 which includes a locking system to lock the PV securely in a heating position during which time the PV is heating using power from a power source in the case and, after the PV has been sufficiently heated, to release the locking mechanism.
10. The case of Concept 9 in which the case automatically moves the PV to a position which allows it to be readily removed from the case by an end-user once the PV has been sufficiently heated.
11. The case of Concept 1 in which the case can be locked as part of a user-defined nicotine or smoking reduction or cessation program.
12. The case of Concept 11 in which locking of the case can be over-ridden by a user but the case then sends an alert signal to a connected smartphone, which tracks the over-ride.
13. The case of Concept 12 in which the smartphone also shares the over-ride, including sharing with other friends of the user connected via a social network.
14. The case of Concept 1 in which the e-liquid includes nicotine and the PV is not a

medicinal device but instead a device that in normal use replaces cigarettes, with the e-liquid being vapourised in the PV and the vapour inhaled to replicate or replace the experience of smoking a cigarette.

15. Method of interacting with an e-liquid e-cigarette PV, including the steps of (a) locking the e-cigarette PV securely in a charging position in a case for a period defined by a nicotine or smoking reduction or cessation program; (b) a user manually over-riding that lock; (c) notifying friends of the user that the lock has been over-ridden.

Feature 5 & 6: Case with data connectivity & e-Fulfilment

1. A portable, personal storage and carrying case for an e-liquid e-cigarette PV in which the case includes (a) user-replaceable e-liquid cartridge; and (b) a fluid transfer system adapted to transfer e-liquid from the cartridge to a chamber in the PV; in which the case includes a data processor that controls sending a signal requesting a replacement for a user-replaceable e-liquid cartridge in the case.

2. The case of Concept 1 in which the case or cartridge detects the level of or quantity of e-liquid in the user-replaceable cartridge.

3. The case of Concept 1 in which the signal is sent to a connected smartphone which in turn connects to an e-fulfilment platform.

4. The case of Concept 1 in which the data processor sends a signal to a connected smartphone indicating that a battery used to re-charge the PV in the case needs re-charging.

5. The case of Concept 1 which measures how much e-liquid is left in the user-replaceable cartridge or whether a replacement is needed by using an ultrasonic ranger.

6. The case of Concept 1 which measures how much e-liquid is left in the user-replaceable cartridge or whether a replacement is needed by using a tilt sensor to detect

the angle of the cartridge and whether the e-liquid closes an electrical circuit between different electrical contacts at different levels within the cartridge.

7. The case of Concept 1 which measures how much e-liquid is left in the user-replaceable cartridge or whether a replacement is needed by measuring the weight of the cartridge.

8. The case of Concept 1 which measures how much e-liquid is left in the user-replaceable cartridge or whether a replacement is needed by using a capacitive sensor.

9. The case of Concept 1 which measures how much e-liquid is left in the user-replaceable cartridge or whether a replacement is needed by using an air pressure sensor at the top of a flexible tube whose bottom is held just above the bottom of the cartridge.

10. The case of Concept 1 which predicts future levels of e-liquid in the cartridge taking into account the rate of consumption by the user and how much e-liquid is left in the PV itself.

11. The case of Concept 1 which predicts future levels of e-liquid in the cartridge taking into account how much e-liquid is left in the PV itself.

12. The case of Concept 1 which includes a cartridge with several compartments and can fill the PV by combining e-liquid from several compartments and the data processor controls sending a signal requesting a replacement for one or more compartments in the cartridge.

13. The case of Concept 1 which includes several user-removable e-liquid cartridges and can fill the PV by combining e-liquid from several cartridges and the data processor controls sending a signal requesting a replacement for one or more of the cartridges.

14. The case of Concept 1 which gives a visual indication when at least one cartridge level is low or needs replacement.

15. The case of Concept 1 which sends a signal to a connected smartphone

indicating that a battery used to re-charge the PV in the case needs re-charging.

16. The case of Concept 1 in which the e-liquid includes nicotine and the PV is not a medicinal device but instead a device that in normal use replaces cigarettes, with the e-liquid being vapourised in the PV and the vapour inhaled to replicate or replace the experience of smoking a cigarette.

17. Method used in portable, personal storage and carrying case adapted specifically for a refillable e-cigarette PV and that re-fills and re-charges the PV, the method including the steps of the case (a) transferring e-liquid from a user-replaceable e-liquid cartridge to the PV and (b) automatically sending a signal requesting a replacement for the user-replaceable e-liquid cartridge to an e-fulfilment platform, either directly or via a connected smartphone.

18. The method of Concept 17 including the steps of the case (a) detecting the level of or quantity of e-liquid in a user-replaceable e-liquid cartridge in the case and (b) automatically sending a signal requesting a replacement for the user-replaceable e-liquid cartridge to an e-fulfilment platform, either directly or via a connected smartphone.

19. The method of Concept 17 in which the signal is sent to a connected smartphone which in turn connects to an e-fulfilment platform.

20. The method of Concept 17 including the step of a machine learning algorithm or system learning the user's e-liquid consumption patterns and using that to determine when to send the signal requesting the replacement e-liquid cartridge.

21. The method of Concept 17 in which the e-liquid includes nicotine and the PV is not a medicinal device but instead a device that in normal use replaces cigarettes, with the e-liquid being vapourised in the PV and the vapour inhaled to replicate or replace the experience of smoking a cigarette.

Section B: PV: Simplicity and ease of use

- | | |
|-------------|----------------------------------|
| Feature 7. | Re-fillable and re-chargeable PV |
| Feature 8. | PV with pre-heat |
| Feature 9. | PV with dosage indication |
| Feature 10. | PV with drip prevention |

Feature 7A: Re-fillable and re-chargeable PV

1. A re-fillable and re-chargeable e-cigarette PV that is not disassembled in normal use for re-filling or replenishing with e-liquid and is also not disassembled in normal use for battery access or replacement or other battery interaction.
2. The e-cigarette PV of Concept 1 in which the PV includes a rechargeable battery, re-fillable e-liquid reservoir and an atomiser, all contained within a casing, and none of which are removable from, or separable from, any part of the casing in normal use.
3. The e-cigarette PV of Concept 1 in which the PV is designed in normal use to only be re-fillable with e-liquid and re-chargeable when inserted into a carrying case for the PV that is specifically adapted to re-fill and re-charge the PV.
4. The e-cigarette PV of Concept 1 in which the PV includes an e-liquid filling aperture positioned centrally along the main axis of the PV to minimise any off-centre forces that could otherwise compromise e-liquid sealing.
5. The e-cigarette PV of Concept 1 in which the PV is adapted to slot or engage with a case that re-fills and re-charges the PV, without the need to dis-assemble or puncture the PV, maintaining the PV whole and intact.
6. The e-cigarette PV of Concept 1 in which the case re-fills and re-charges the PV, without the need to dis-assemble or puncture the PV, via an e-liquid filling nozzle formed in one end of the mouthpiece, the e-liquid filling nozzle being separate from vapour inhalation nozzle(s).

7. The e-cigarette PV of Concept 1 in which an aperture in the PV aligns with a hollow tube or shaft that is part of a pump and the aperture includes a flexible seal through which the tube is inserted, the seal ensuring that any drips of e-liquid are retained within the PV.
8. The e-cigarette PV of Concept 1 in which the tip of the PV includes a fluid trap and absorbent wicking to capture any fluid leakage.
9. The e-cigarette PV of Concept 1 in which a hollow tube or shaft extends up from the central axis of a hollow compartment into which the PV is inserted.
10. The e-cigarette PV of Concept 1 in which the PV re-fills using a fluid transfer system in which the PV moves relative to a pump.
11. The e-cigarette PV of Concept 10 in which the PV re-fills using a pump activated by depressing and releasing the entire, complete PV whilst the PV whilst it is held in a holder, the PV sliding up and down within the holder.
12. The e-cigarette PV of Concept 1 in which the PV is re-filled by a mechanical camming caused by the top of the PV being pressed or cammed downwards when it is closed inside a carrying case, the camming action depressing the PV so that it completes a downstroke of the pumping action.
13. The e-cigarette PV of Concept 1 in which the PV is filled by a motor moving the PV up and down in relation to a pump, or the pump in relation to the PV.
14. The e-cigarette PV of Concept 1 in which the PV is adapted to slot or engage with a case that includes a hinged compartment that the PV is slotted into, mouthpiece end downwards, and which guides an aperture of the PV into contact with a pump nozzle that fills a chamber in the PV with e-liquid until the pressure in the chamber equals the pressure in an e-liquid cartridge in the case.
15. The e-cigarette PV of Concept 1 in which the PV is adapted to slot or engage with a case that automatically re-fills and re-charges the e-cigarette PV, the case including

a hinged compartment that the PV is slotted into, mouthpiece end downwards, and which, whenever the hinged compartment is closed, cams the PV downwards to prime or activate a pump nozzle that will deliver e-liquid from a cartridge into a chamber in the PV until the pressure in the chamber equals the pressure in an e-liquid cartridge in the case.

16. The e-cigarette PV of Concept 1 in which the case automatically re-fills an e-cigarette PV via an e-liquid nozzle at the centre of the mouthpiece end of the PV from a user-replaceable e-liquid cartridge in the case, the case including a micro-pump designed to slot into or be received by an aperture in the cartridge.

17. The e-cigarette PV of Concept 1 in which a nozzle or aperture in the PV engages with a micro-pump formed in a user-replaceable e-liquid cartridge.

18. The e-cigarette PV of Concept 1 in which the e-liquid includes nicotine and the PV is not a medicinal device but instead a device that in normal use replaces cigarettes, with the e-liquid being vapourised in the PV and the vapour inhaled to replicate or replace the experience of smoking a cigarette.

19. The e-cigarette PV of Concept 1 which is designed to be withdrawn from the case prior to re-filling and then inserted against a nozzle in the case for re-filling.

20. A re-fillable and re-chargeable e-cigarette PV in which the PV includes a rechargeable battery, re-fillable e-liquid reservoir and an atomiser, all contained within a casing, and none of which are removable from, or separable from, any part of the casing in normal use.

21. A re-fillable and re-chargeable e-cigarette PV in which the PV is designed in normal use to only be re-fillable with e-liquid and re-chargeable when inserted into a carrying case for the PV that is specifically adapted to re-fill and re-charge the PV.

Feature 7B: Re-fillable and re-chargeable PV

1. A re-fillable and re-chargeable e-cigarette PV in which the PV has a tip that includes (a) an e-liquid filling aperture that is designed to engage an e-liquid transfer mechanism (b) one or more vapour outlets distributed around the e-liquid filling aperture; and electrical charging contacts spaced apart from the tip.
2. The e-cigarette PV of Concept 1 in which the electrical charging contacts are at the opposite end of the PV compared with the tip.
3. The e-cigarette PV of Concept 2 in which the electrical contacts are incorporated into a contact assembly that includes electrical contacts to transfer power from the case to a battery in the PV and also electrical contacts to transfer data to and/or from the PV.
4. The e-cigarette PV of Concept adapted to be slid into a personal, portable storage and carrying case that can both re-charge a local battery in the PV and re-fill an e-liquid chamber in the PV.
5. The e-cigarette PV of Concept 1 that is not disassembled in normal use for re-filling or replenishing with e-liquid and is also not disassembled in normal use for battery access or replacement or other battery interaction.
6. The e-cigarette PV of Concept 1 in which the PV includes a rechargeable battery, re-fillable e-liquid reservoir and an atomiser, all contained within a casing, and none of which are removable from, or separable from, any part of the casing in normal use.
7. The e-cigarette PV of Concept 1 in which the PV is designed in normal use to only be re-fillable with e-liquid and re-chargeable when inserted into a carrying case for the PV that is specifically adapted to re-fill and re-charge the PV.
8. The e-cigarette PV of Concept 1 in which the PV includes an e-liquid filling aperture positioned centrally along the main axis of the PV to minimise any off-centre forces that could otherwise compromise e-liquid sealing.
9. The e-cigarette PV of Concept 1 in which the PV is adapted to slot or engage with a case that re-fills and re-charges the PV, without the need to dis-assemble or

puncture the PV, maintaining the PV whole and intact.

10. The e-cigarette PV of Concept 1 in which the case re-fills and re-charges the PV, without the need to dis-assemble or puncture the PV, via an e-liquid filling nozzle formed in one end of the mouthpiece, the e-liquid filling nozzle being separate from vapour inhalation nozzle(s).

11. The e-cigarette PV of Concept 1 in which an aperture in the PV aligns with a hollow tube or shaft that is part of a pump and the aperture includes a flexible seal through which the tube is inserted, the seal ensuring that any drips of e-liquid are retained within the PV.

12. The e-cigarette PV of Concept 1 in which the tip of the PV includes a fluid trap and absorbent wicking to capture any fluid leakage.

13. The e-cigarette PV of Concept 1 in which a hollow tube or shaft extends up from the central axis of a hollow compartment into which the PV is inserted.

14. The e-cigarette PV of Concept 1 in which the PV re-fills using a fluid transfer system in which the PV moves relative to a pump.

15. The e-cigarette PV of Concept 14 in which the PV re-fills using a pump activated by depressing and releasing the entire, complete PV whilst the PV whilst it is held in a holder, the PV sliding up and down within the holder.

16. The e-cigarette PV of Concept 14 in which the PV is re-filled by a mechanical camming caused by the top of the PV being pressed or cammed downwards when it is closed inside a carrying case, the camming action depressing the PV so that it completes a downstroke of the pumping action.

17. The e-cigarette PV of Concept 14 in which the PV is filled by a motor moving the PV up and down in relation to a pump, or the pump in relation to the PV.

18. The e-cigarette PV of Concept 1 in which the PV is adapted to slot or engage

with a case that includes a hinged compartment that the PV is slotted into, mouthpiece end downwards, and which guides an aperture of the PV into contact with a pump nozzle that fills a chamber in the PV with e-liquid until the pressure in the chamber equals the pressure in an e-liquid cartridge in the case.

19. The e-cigarette PV of Concept 1 in which the PV is adapted to slot or engage with a case that automatically re-fills and re-charges the e-cigarette PV, the case including a hinged compartment that the PV is slotted into, mouthpiece end downwards, and which, whenever the hinged compartment is closed, cams the PV downwards to prime or activate a pump nozzle that will deliver e-liquid from a cartridge into a chamber in the PV until the pressure in the chamber equals the pressure in an e-liquid cartridge in the case.

20. The e-cigarette PV of Concept 1 in which the case automatically re-fills an e-cigarette PV via an e-liquid nozzle at the centre of the mouthpiece end of the PV from a user-replaceable e-liquid cartridge in the case, the case including a micro-pump designed to slot into an aperture in the cartridge.

21. The e-cigarette PV of Concept 1 in which a nozzle or aperture in the PV engages with a micro-pump formed in a user-replaceable e-liquid cartridge.

22. The e-cigarette PV of Concept 1 in which the e-liquid includes nicotine and the PV is not a medicinal device but instead a device that in normal use replaces cigarettes, with the e-liquid being vapourised in the PV and the vapour inhaled to replicate or replace the experience of smoking a cigarette.

Feature 8: PV with Pre-heat

1. A re-fillable and re-chargeable e-cigarette PV in which the PV is locked securely in a heating position by a locking system in a portable case, during which time the PV is heating its atomiser whilst connected to a power source in the case and, after the PV has been sufficiently heated, is released from the locking system.

2. The e-cigarette PV of Concept 1 in which the PV is automatically released from the locking system and moved to a position which allows it to be readily removed from the case by an end-user, once the PV has been sufficiently heated.
3. The e-cigarette PV of Concept 1 in which the PV automatically starts heating its atomiser using its own internal power source only when the PV detects that it is no longer in electrical contact with charging contacts in the portable case in which it was stored.
4. The e-cigarette PV of Concept 1 in which the PV is automatically heated whilst connected to a power source in the case only if a mechanical inter-lock operates to secure the PV in position.
5. The e-cigarette PV of Concept 1 in which electrical charging contacts in the case are positioned on a sliding contact block that operates as the mechanical inter-lock and that moves from a first position in which it is not physically engaged with the PV and a second position in which it is itself locked in position and also secures the PV in position.
6. The e-cigarette PV of Concept 5 in which the sliding contact block also includes data transfer contacts that engage directly or indirectly with data transfer contacts in the PV
7. The e-cigarette PV of Concept 1 including inductive power transfer coils.
8. The e-cigarette PV of Concept 1 which can be locked by the mechanical inter-lock to prevent under-age or unauthorised use.
9. The e-cigarette PV of Concept 8 in which the mechanical inter-lock can be locked and unlocked using data sent or exchanged with the authorised user's smartphone
10. The e-cigarette PV of Concept 1 in which the PV is automatically locked into a secured re-charging position when the case is fully closed for storage and carrying the PV.

11. The e-cigarette PV of Concept 1 in which a heating coil is arranged longitudinally along the long axis of the PV.
12. The e-cigarette PV of Concept 1 in which the PV includes a rechargeable battery, re-fillable e-liquid reservoir and an atomiser, all contained within a casing, and none of which are removable from, or separable from, any part of the casing in normal use.
13. The e-cigarette PV of Concept 1 in which the PV designed in normal use to only be re-fillable with e-liquid and re-chargeable when inserted into the case for the PV, the case being specifically adapted to re-fill and re-charge the PV.
14. The e-cigarette PV of Concept 1 in which the PV has a tip that includes (a) an e-liquid filling aperture that is designed to engage an e-liquid transfer mechanism (b) one or more vapour outlets distributed around the e-liquid filling aperture; and electrical charging contacts spaced apart from the tip.
15. The e-cigarette PV of Concept 1 in which additional heating of the e-liquid is performed by secondary heating elements in the PV e-liquid chamber.
16. The e-cigarette PV of Concept 1 in which heating of the e-liquid to the temperature at which the PV is ready for use can be predicted or inferred with sufficient accuracy because the charge level of the battery in the PV used to provide power to heat the e-liquid is known reliably.
17. The e-cigarette PV of Concept 16 in which the charge level is known reliably because a sensor directly measures that charge level.
18. The e-cigarette PV of Concept 16 in which the charge level is known reliably because it can be assumed to be fully charged because the device is stored in the portable case that includes a battery that automatically charges the battery in the device.
19. The e-cigarette PV of Concept 1 in which the e-liquid includes nicotine and the PV is not a medicinal device but instead a device that in normal use replaces cigarettes,

with the e-liquid being vapourised in the PV using a heated element and the vapour inhaled to replicate or replace the experience of smoking a cigarette.

20. A portable, personal storage and carrying case for an e-liquid e-cigarette PV that starts providing power to heat an electrical atomising element in a PV automatically when the case in which the PV is stored is opened.

Feature 9: PV with dosage indication

1. A re-fillable and re-chargeable e-cigarette PV in which the PV indicates consumption of e-liquid using a visual indicator that extends or moves along the body.

2. The e-cigarette PV of Concept 1 in which the visual indicator moves or extends down the body of the PV away from the mouthpiece

3. The e-cigarette PV of Concept 1 in which the visual indicator moves or extends fully to indicate that a single dose of nicotine has been consumed.

4. The e-cigarette PV of Concept 3 in which the single dose is defined by a user.

5. The e-cigarette PV of Concept 3 in which the single dose corresponds approximately to the nicotine in a single cigarette.

6. The e-cigarette PV of Concept 1 in which the visual indicator is a row of LEDs or other indicators and each indicator changes appearance when a single inhalation occurs.

7. The e-cigarette PV of Concept 1 in which the visual indicator is a row of LEDs or other indicators and each indicator changes appearance when inhalations corresponding to smoking a single cigarette occurs.

8. The e-cigarette PV of Concept 1 in which a heating coil is arranged longitudinally along the long axis of the PV.

9. The e-cigarette PV of Concept 1 in which a user can control the airflow through the PV by manually altering the size of air inlet vents in the PV.
10. The e-cigarette PV of Concept 1 in which the e-liquid includes nicotine and the PV is not a medicinal device but instead a device that in normal use replaces cigarettes, with the e-liquid being vapourised in the PV and the vapour inhaled to replicate or replace the experience of smoking a cigarette.

Feature 10: PV Drip prevention

1. A re-fillable and re-chargeable e-cigarette PV in which the PV includes a tip that includes (a) an e-liquid filling aperture or nozzle that is designed to engage an e-liquid transfer mechanism, the aperture or nozzle being centrally positioned along the long axis of the PV, the aperture or nozzle being connected to an e-liquid storage chamber in the PV; (b) one or more vapour outlets distributed around the e-liquid filling aperture; and in which the or each vapour outlet is connected by a passage to a vapour chamber including a vaporising element, and the vapour chamber is sealed from the e-liquid storage chamber.
2. The e-cigarette PV of Concept 1 in which the PV has an e-liquid leak suppression feature in which an e-liquid filling aperture or nozzle in the PV is adapted to align, when inserted into a re-filling unit, with a hollow tube that is part of a fluid transfer system in the re-filling unit, and the aperture or nozzle includes a flexible seal through which the tube is inserted or passes, the seal ensuring that any drips of e-liquid are retained within the PV when the PV is withdrawn from or removed from the re-filling unit.
3. The e-cigarette PV of Concept 1 in which the PV is adapted to slot into or engage with a case that re-fills and re-charges the PV, without the need to dis-assemble or puncture the PV, maintaining the PV whole and intact.
4. The e-cigarette PV of Concept 1 in which the passage that connects a vapour outlet to the vapour chamber is lined with material that can absorb e-liquid droplets.

5. The e-cigarette PV of Concept 1 in which the tip of the PV includes a fluid trap and material that can absorb e-liquid droplets to capture any fluid leakage.
6. The e-cigarette PV of Concept 1 in which the vapour passage is not a straight through path from the vapour chamber but instead includes at least one turn.
7. The e-cigarette PV of Concept 1 in which a hollow tube or shaft extends up from the central axis of a hollow compartment into which the PV is inserted.
8. The e-cigarette PV of Concept 1 in which the PV re-fills using a fluid transfer system in which the PV moves relative to a pump.
9. The e-cigarette PV of Concept 8 in which the PV re-fills using a pump activated by depressing and releasing the entire, complete PV whilst the PV whilst it is held in a holder, the PV sliding up and down within the holder.
10. The e-cigarette PV of Concept 1 in which the PV is re-filled by a mechanical camming caused by the top of the PV being pressed or cammed downwards when it is closed inside a carrying case, the camming action depressing the PV so that it completes a downstroke of the pumping action.
11. The e-cigarette PV of Concept 1 in which the PV is filled by a motor moving the PV up and down in relation to a pump, or the pump in relation to the PV.
12. The e-cigarette PV of Concept 1 in which the PV is adapted to slot or engage with a case that includes a hinged compartment that the PV is slotted into, mouthpiece end downwards, and which guides an aperture of the PV into contact with a pump nozzle that fills a reservoir in the PV with e-liquid until the pressure in the reservoir equals the pressure in an e-liquid cartridge in the case.
13. The e-cigarette PV of Concept 1 in which the PV is adapted to slot or engage with a case that automatically re-fills and re-charges the e-cigarette PV, the case including a hinged compartment that the PV is slotted into, mouthpiece end downwards, and

which, whenever the hinged compartment is closed, cams the PV downwards to prime or activate a pump nozzle that will deliver e-liquid from a cartridge into a reservoir in the PV until the pressure in the reservoir equals the pressure in an e-liquid cartridge in the case.

14. The e-cigarette PV of Concept 1 in which the case automatically re-fills an e-cigarette PV via an e-liquid nozzle at the centre of the mouthpiece end of the PV from a user-replaceable e-liquid cartridge in the case, the case including a micro-pump designed to slot into an aperture in the cartridge.

15. The e-cigarette PV of Concept 1 in which a nozzle or aperture in the PV engages with a micro-pump formed in a user-replaceable e-liquid cartridge.

16. The e-cigarette PV of Concept 1 in which the e-liquid includes nicotine and the PV is not a medicinal device but instead a device that in normal use replaces cigarettes, with the e-liquid being vapourised in the PV and the vapour inhaled to replicate or replace the experience of smoking a cigarette.

In this final part of Appendix 1, we will summarise the user-replaceable e-liquid cartridge concepts.

Section C: User-replaceable e-liquid cartridge

Feature 11: User-replaceable e-liquid cartridge that fits into the portable storage and carrying case

1. A user-replaceable e-liquid cartridge adapted to be inserted into or attached to a portable, personal storage and carrying case for an e-liquid e-cigarette PV.
2. The e-liquid cartridge of Concept 1 in which the combination of cartridge and case forms in normal use a portable, personal device for the storage and carrying of the PV and its re-filling with e-liquid.
3. The e-liquid cartridge of Concept 1 in which the cartridge has a casing that is adapted to be fitted by a user into a chamber in the portable, personal storage and carrying case.
4. The e-liquid cartridge of Concept 1 in which the cartridge has an outer surface that forms part of the outside of the case or an extension to the case, with case and cartridge when combined forming an object that in normal use can be stored in a pocket.
5. The e-liquid cartridge of Concept 1 in which the e-liquid capacity of the user replaceable cartridge is at least three times, and preferably five times, greater than the e-liquid capacity of an e-liquid chamber in the PV.
6. The e-liquid cartridge of Concept 1 adapted to engage with a fluid transfer system in the case.
7. The e-liquid cartridge of Concept 6 adapted to engage with a fluid transfer system in the case that is a pump that delivers e-liquid into the PV approximately equivalent to a single cigarette for each pumping stroke.

8. The e-liquid cartridge of Concept 1 in which the e-liquid cartridge is designed in normal use to permit e-liquid to escape from the cartridge only if the cartridge is correctly positioned in or attached to the case.
9. The e-liquid cartridge of Concept 1 in which the cartridge is not substantially deformable in normal use in order to displace fluid from the cartridge.
10. The e-liquid cartridge of Concept 1 in which the e-liquid cartridge is designed to slot inside the portable, personal storage and carrying case for an e-liquid e-cigarette PV with a press fit against a seal and in which the cartridge is formed with a void designed to receive and engage with a micro-pump that is positioned in the case, the micro-pump sealing against a nozzle or aperture in the cartridge.
11. The e-liquid cartridge of Concept 1 in which the cartridge includes an integral micro-pump.
12. The e-liquid cartridge of Concept 11 in which the cartridge includes an overflow channel that enables excess e-liquid that is pumped up from the cartridge but is not stored in the PV to be captured and returned to the cartridge.
13. The e-liquid cartridge of Concept 1, being one of several cartridges inserted in or attached to the case, in which the case is operable to select a specific desired cartridge or to mix e-liquid from several cartridges.
14. The e-liquid cartridge of Concept 1 including several compartments, each with a different e-liquid.
15. The e-liquid cartridge of Concept 1 which includes an electronic identifier, such as an RFID chip.
16. The e-liquid cartridge of Concept 1 in which the cartridge includes physical features on its surface, such as raised or lowered portions, that physically engage with complimentary features in the wall of the case aperture into which the cartridge is inserted.

17. The e-liquid cartridge of Concept 16 in which the physical features form the shape of a word or logo, such as a trademarked word or logo
18. The e-liquid cartridge of Concept 1 that is adapted to be removed from the storage and carrying case and replaced with a new e-liquid cartridge in normal use by an end-user.
19. The e-liquid cartridge of 18 with a flavour or nicotine strength selected from a range of different available flavours or nicotine strengths.
20. The e-liquid cartridge of Concept 1 adapted so that the level of or quantity of e-liquid in the cartridge or used by the cartridge can be measured or inferred so that a timely signal indicating that a replacement cartridge is needed can be generated.
21. The e-liquid cartridge of Concept 20 in which the signal is sent to a connected smartphone which in turn connects to an e-fulfilment platform.
22. The e-liquid cartridge of preceding Concept 20 that interacts with an ultrasonic range that measures how much e-liquid is left in the cartridge or whether a replacement is needed.
23. The e-liquid cartridge of preceding Concept 20 that interacts with a tilt sensor to detect the angle of the cartridge and whether the e-liquid in the cartridge closes an electrical circuit between different electrical contacts at different levels within the cartridge.
24. The e-liquid cartridge of preceding Concept 20 that interacts with a weight sensor that weighs the cartridge.
25. The e-liquid cartridge of preceding Concept 20 that interacts with a capacitive sensor that detects the level of e-liquid in the cartridge.

26. The e-liquid cartridge of preceding Concept 20 that interacts with an air pressure sensor at the top of a flexible tube whose bottom is held just above the bottom of the cartridge.

27. The e-liquid cartridge of Concept 1 in which the e-liquid includes nicotine and the PV is not a medicinal device but instead a device that in normal use replaces cigarettes, with the e-liquid being vapourised in the PV and the vapour inhaled to replicate or replace the experience of smoking a cigarette.

28. The e-liquid cartridge of Concept 28 which contains nicotine equivalent to approximately one hundred cigarettes.

29. Method for sending a signal relating to the status of a user-replaceable e-liquid cartridge used in a portable, personal storage and carrying case adapted specifically for a refillable e-cigarette PV and that re-fills and re-charges the PV, the method including the steps (a) transferring e-liquid from a user-replaceable e-liquid cartridge to the PV and (b) automatically sending a signal requesting a replacement for the user-replaceable e-liquid cartridge to an e-fulfilment platform, either directly or via a connected smartphone.

30. The method of Concept 29 including the steps of (a) detecting the level of or quantity of e-liquid in a user-replaceable e-liquid cartridge in the case and (b) automatically sending a signal requesting a replacement for the user-replaceable e-liquid cartridge to an e-fulfilment platform, either directly or via a connected smartphone.

End of Appendix 1

CLAIMS

1. A re-fillable and re-chargeable e-cigarette PV that is not disassembled in normal use for re-filling or replenishing with e-liquid and is also not disassembled in normal use for battery access or replacement or other battery interaction.
2. The e-cigarette PV of Claim 1 in which the PV includes a rechargeable battery, re-fillable e-liquid reservoir and an atomiser, all contained within a casing, and none of which are removable from, or separable from, any part of the casing in normal use.
3. The e-cigarette PV of preceding Claim 1 or 2 in which the PV designed in normal use to only be re-fillable with e-liquid and re-chargeable when inserted into a carrying case for the PV that is specifically adapted to re-fill and re-charge the PV.
4. The e-cigarette PV of any preceding Claim in which the PV has a tip that includes (a) an e-liquid filling aperture that is designed to engage an e-liquid transfer mechanism (b) one or more vapour outlets distributed around the e-liquid filling aperture; and electrical charging contacts spaced apart from the tip.
5. The e-cigarette PV of any preceding Claim in which the PV includes an e-liquid filling aperture positioned centrally along the main axis of the PV to minimise any off-centre forces that could otherwise compromise e-liquid sealing.
6. The e-cigarette PV of any preceding Claim in which the PV is adapted to slot or engage with a case that re-fills and re-charges the PV, without the need to dis-assemble or puncture the PV, maintaining the PV whole and intact.
7. The e-cigarette PV of any preceding Claim in which the case re-fills and re-charges the PV, without the need to dis-assemble or puncture the PV, via an e-liquid filling nozzle formed in one end of the mouthpiece, the e-liquid filling nozzle being separate from vapour inhalation nozzle(s).

8. The e-cigarette PV of any preceding Claim in which an aperture in the PV aligns with a hollow tube or shaft that is part of a pump and the aperture includes a flexible seal through which the tube is inserted, the seal ensuring that any drips of e-liquid are retained within the PV.
9. The e-cigarette PV of any preceding Claim in which the tip of the PV includes a fluid trap and absorbent wicking to capture any fluid leakage.
10. The e-cigarette PV of any preceding Claim in which a hollow tube or shaft extends up from the central axis of a hollow compartment into which the PV is inserted.
11. The e-cigarette PV of any preceding Claim in which the PV re-fills using a fluid transfer system in which the PV moves relative to a pump.
12. The e-cigarette PV of any preceding Claim in which the PV re-fills using a pump activated by depressing and releasing the entire, complete PV whilst the PV is held in a hinged compartment of the case.
13. The e-cigarette PV of any preceding Claim in which the PV re-fills using a fluid transfer system, for example a gravity feed or a pump activated by depressing and releasing the PV, contacting a hollow tube of the pump that is aligned with an aperture in the PV.
14. The e-cigarette PV of any preceding Claim in which the PV is re-filled by the user manually depressing and releasing the PV whilst it is held in a holder, the PV sliding up and down within the holder.
15. The e-cigarette PV of any preceding Claim in which the PV is re-filled by a mechanical camming action caused by the top of the PV being pressed or cammed downwards when it is closed inside a carrying case, the camming action depressing the PV so that it completes a downstroke of the pumping action.
16. The e-cigarette PV of any preceding Claim in which the PV is filled by a motor moving the PV up and down in relation to a pump, or the pump in relation to the PV.

17. The e-cigarette PV of any preceding Claim in which the PV is adapted to slot or engage with a case that includes a hinged compartment that the PV is slotted into, mouthpiece end downwards, and which guides an aperture of the PV into contact with a pump nozzle that fills a reservoir in the PV with e-liquid until the pressure in the reservoir equals the pressure in an e-liquid cartridge in the case.

18. The e-cigarette PV of any preceding Claim in which the PV is adapted to slot or engage with a case that automatically re-fills and re-charges the e-cigarette PV, the case including a hinged compartment that the PV is slotted into, mouthpiece end downwards, and which, whenever the hinged compartment is closed, cams the PV downwards to prime or activate a pump nozzle that will deliver e-liquid from a cartridge into a reservoir in the PV until the pressure in the reservoir equals the pressure in an e-liquid cartridge in the case.

19. The e-cigarette PV of any preceding Claim in which the case automatically re-fills an e-cigarette PV via an e-liquid nozzle at the centre of the mouthpiece end of the PV from a user-replaceable e-liquid cartridge in the case, the case including a micro-pump designed to slot into an aperture in the cartridge.

20. The e-cigarette PV of any preceding Claim in which a nozzle or aperture in the PV engages with a micro-pump formed in a user-replaceable e-liquid cartridge.

21. The e-cigarette PV of any preceding Claim in which the PV automatically starts heating an electrical atomising element when the PV detects that it is no longer in electrical contact with the charging contacts in a portable carry case in which it is stored.

22. The e-cigarette PV of any preceding Claim in which the PV is locked securely in a heating position by a locking mechanism in the case, during which time the PV is heating using power from a power source in the case and, after the PV has been sufficiently heated, is released from the locking mechanism.

23. The e-cigarette PV of any preceding Claim in which the PV indicates consumption of e-liquid using a visual indicator that extends or moves along the body,

such as down the body of the PV away from the mouthpiece.

24. The e-cigarette PV of preceding Claim 23 in which the visual indicator moves or extends fully to indicate that a single dose has been consumed.

25. The e-cigarette PV of preceding Claim 23 or 24 in which the visual indicator is a row of LEDs or other indicators and each indicator changes appearance when a single inhalation occurs.

26. The e-cigarette PV of preceding Claim 23 or 24 in which the visual indicator is a row of LEDs or other indicators and each indicator changes appearance when inhalations corresponding to smoking a single cigarette occurs.

27. The e-cigarette PV of any preceding Claim in which the PV includes a tip that includes (a) an e-liquid filling aperture that is designed to engage an e-liquid transfer mechanism, the aperture being centrally positioned along the long axis of the PV, the aperture being connected to an e-liquid storage chamber in the PV; (b) one or more vapour outlets distributed around the e-liquid filling aperture; and in which the or each vapour outlet is connected by a passage to a vapour chamber including a vaporising element, and the vapour chamber is sealed from the e-liquid storage chamber.

28. The e-cigarette PV of any preceding Claim in which the PV has an e-liquid leak suppression feature in which an e-liquid filling aperture in the PV is adapted to align, when inserted into a re-filling unit, with a hollow tube that is part of a fluid transfer system in the re-filling unit, and the aperture includes a flexible seal through which the tube is inserted or passes, the seal ensuring that any drips of e-liquid are retained within the PV when the PV is withdrawn from or removed from the re-filling unit.

29. The e-cigarette PV of any preceding Claim in which a heating coil is arranged longitudinally along the long axis of the PV.

30. The e-cigarette PV of any preceding Claim in which a user can control the airflow through the PV by manually altering the size of air inlet vents in the PV.

31. The e-cigarette PV of any preceding Claim in which the e-liquid includes nicotine and the PV is not a medicinal device but instead a device that in normal use replaces cigarettes, with the e-liquid being vapourised in the PV and the vapour inhaled to replicate or replace the experience of smoking a cigarette.

1/77

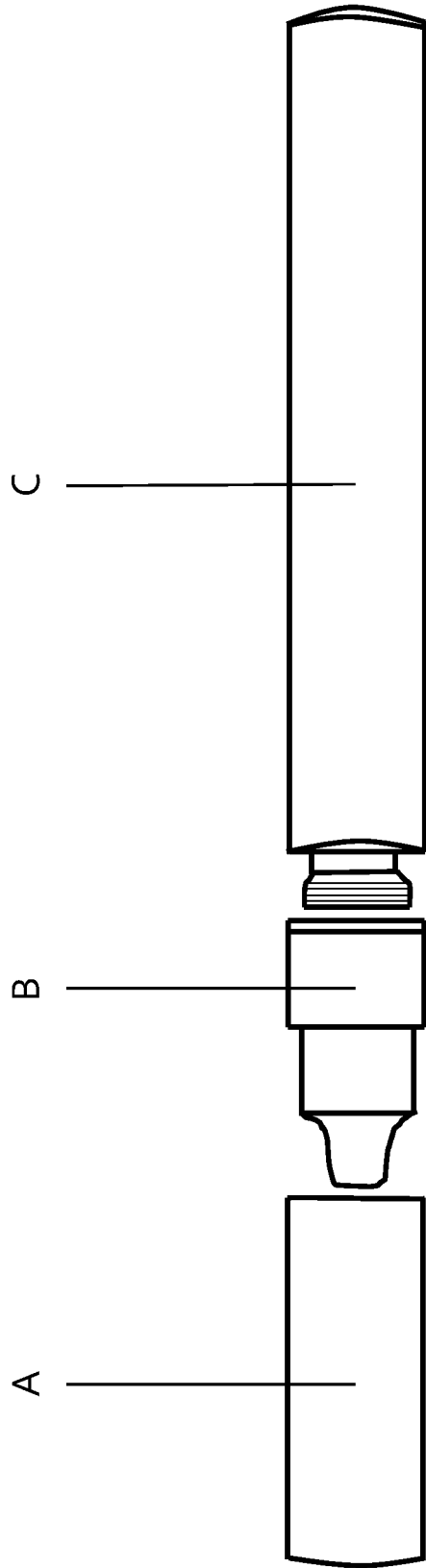

FIGURE 1 Prior art

2/77

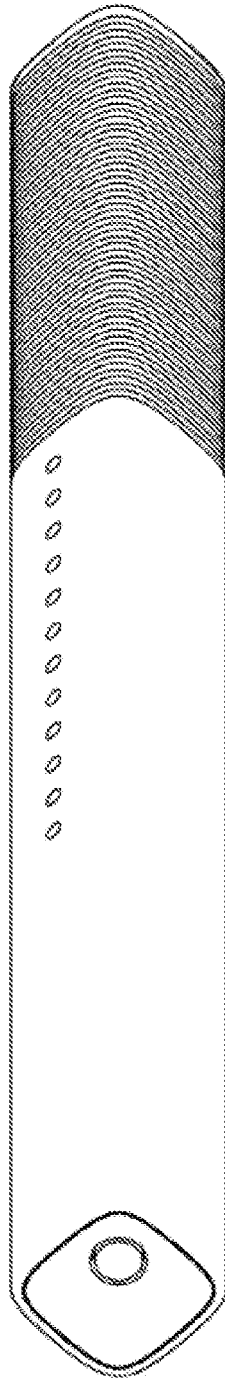

FIGURE 2

3/77

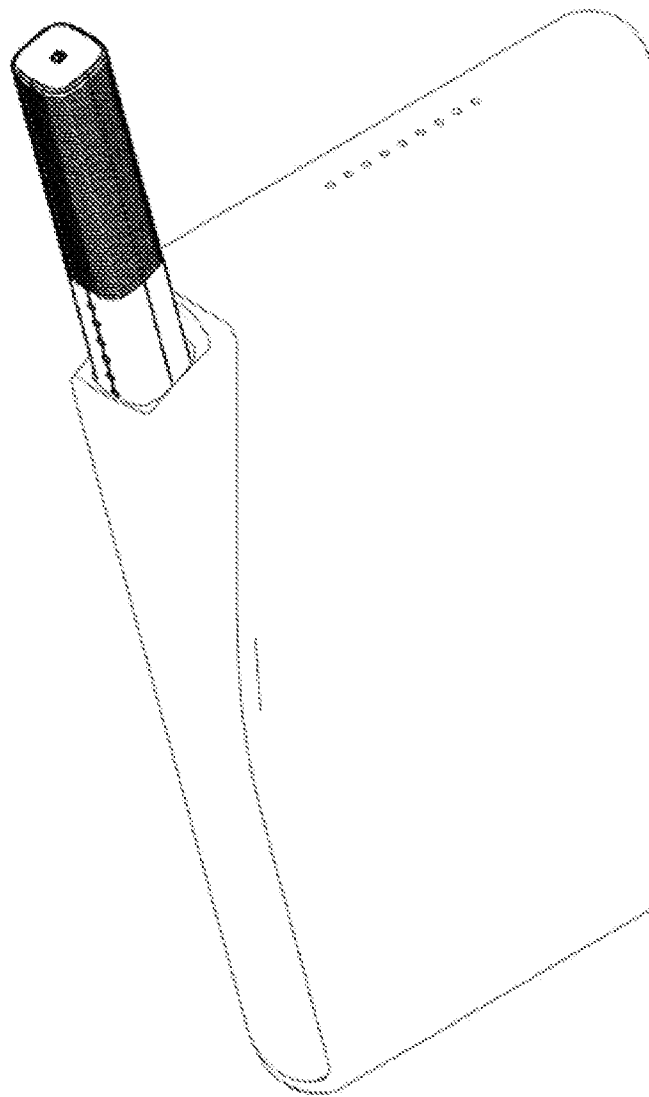

FIGURE 3

4/77

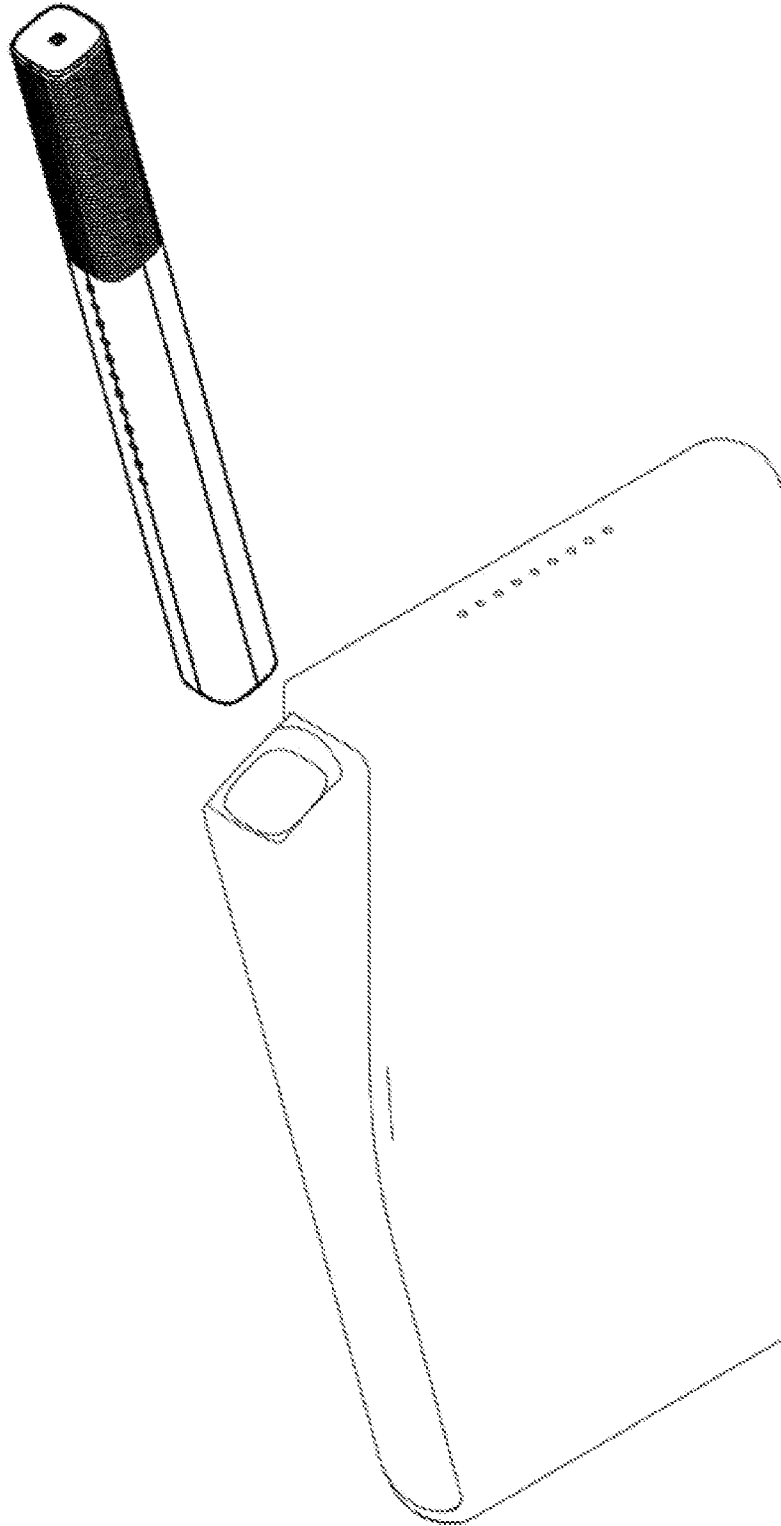

FIGURE 4

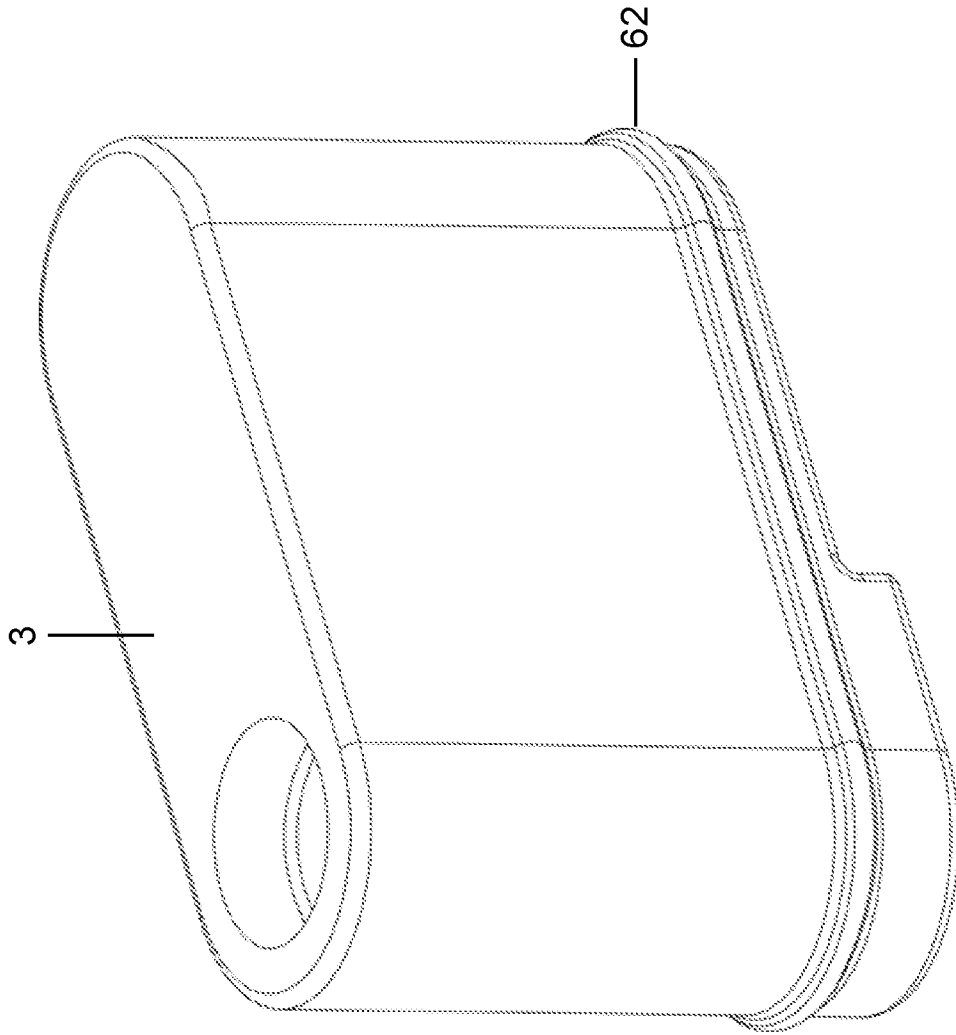

FIGURE 5

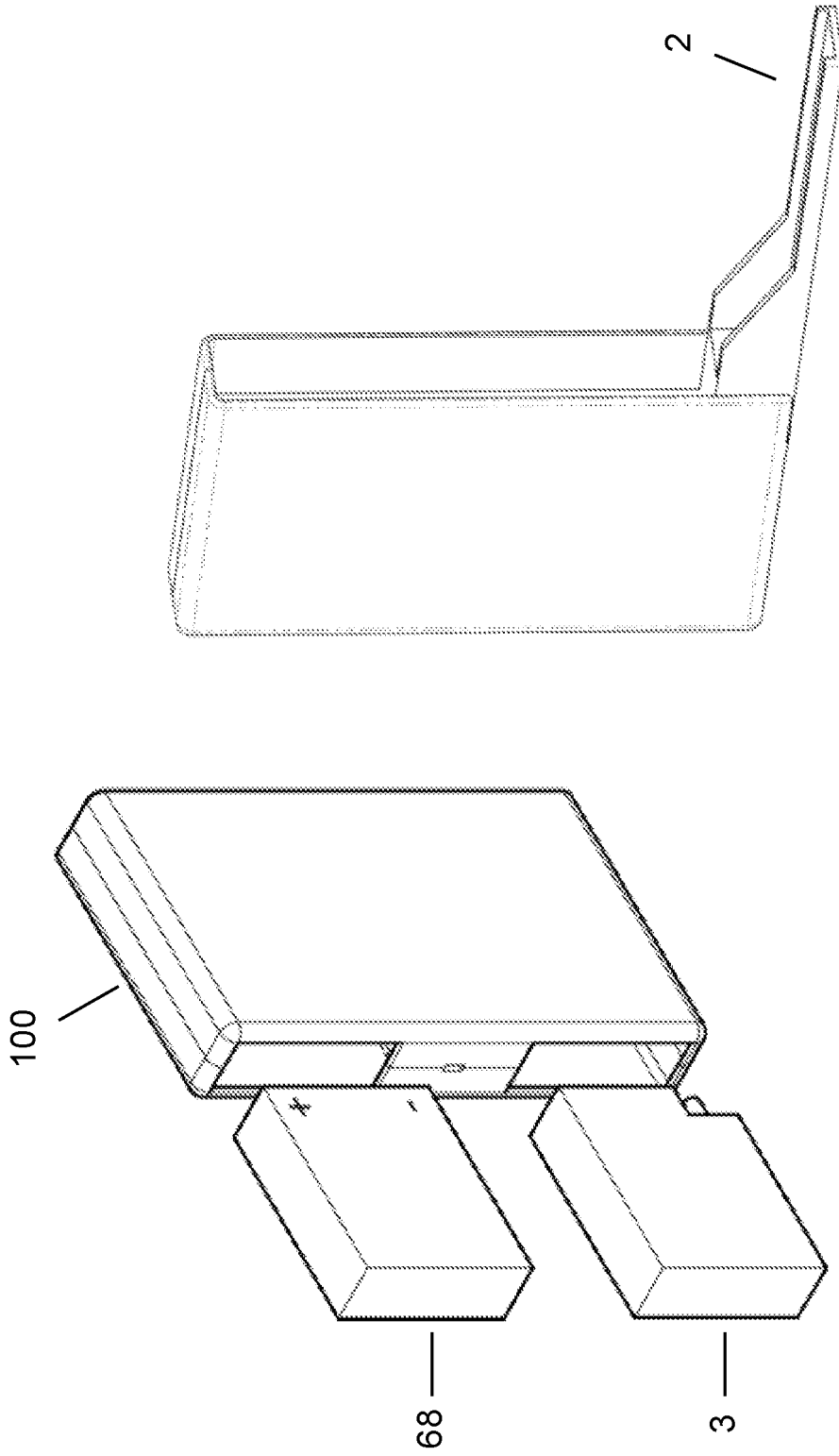

FIGURE 6B

FIGURE 6A

7/77

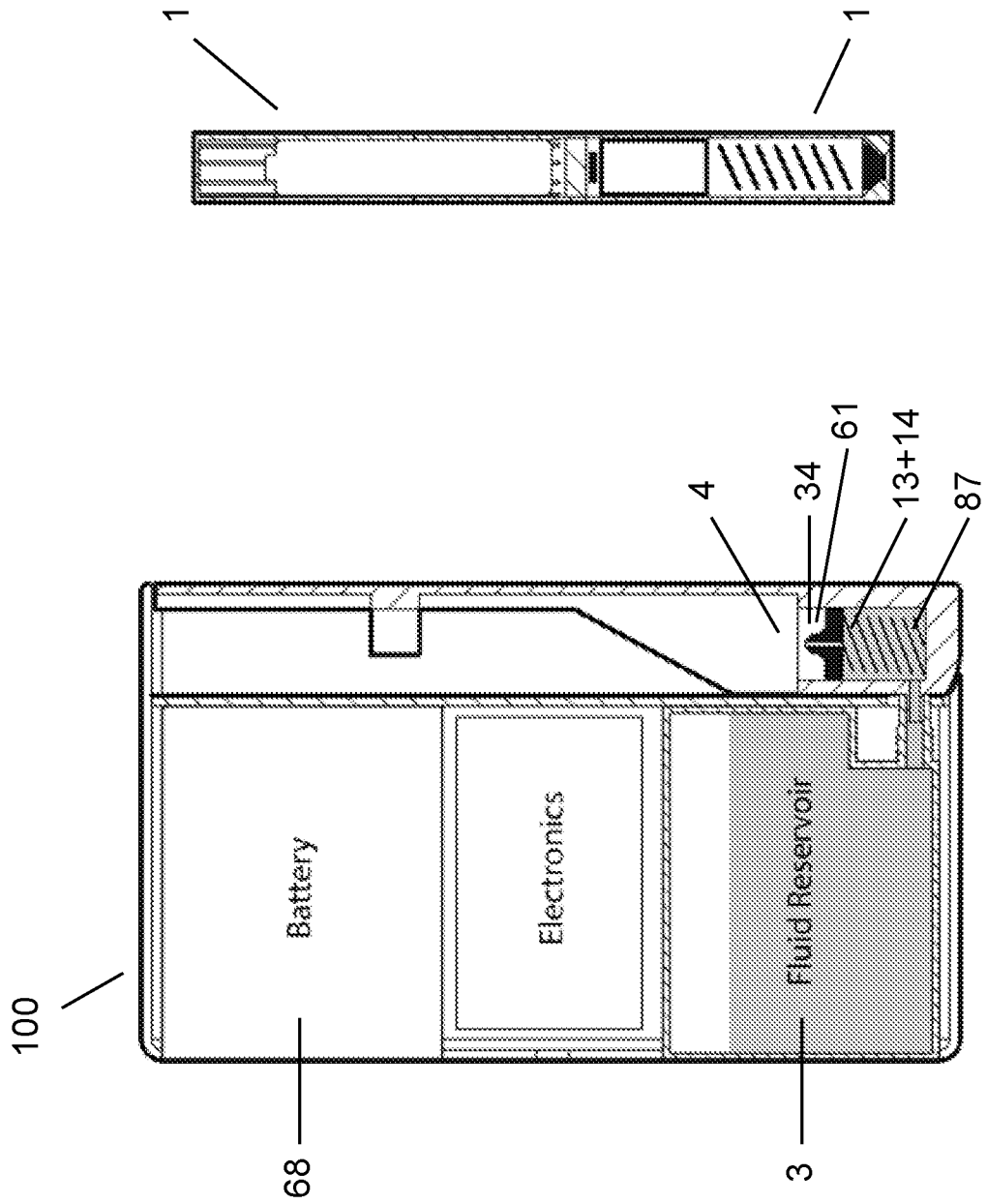

FIGURE 7

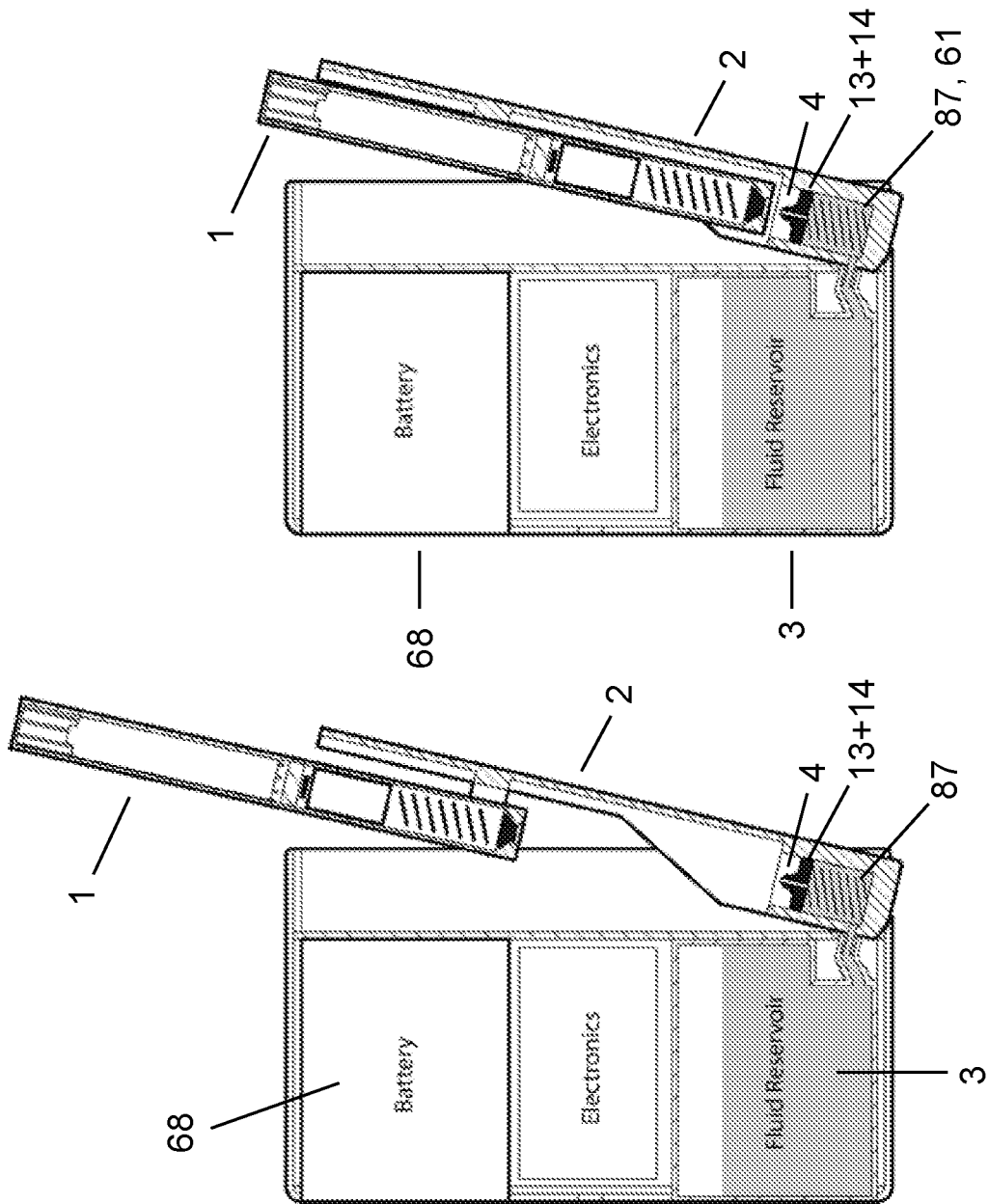

FIGURE 8

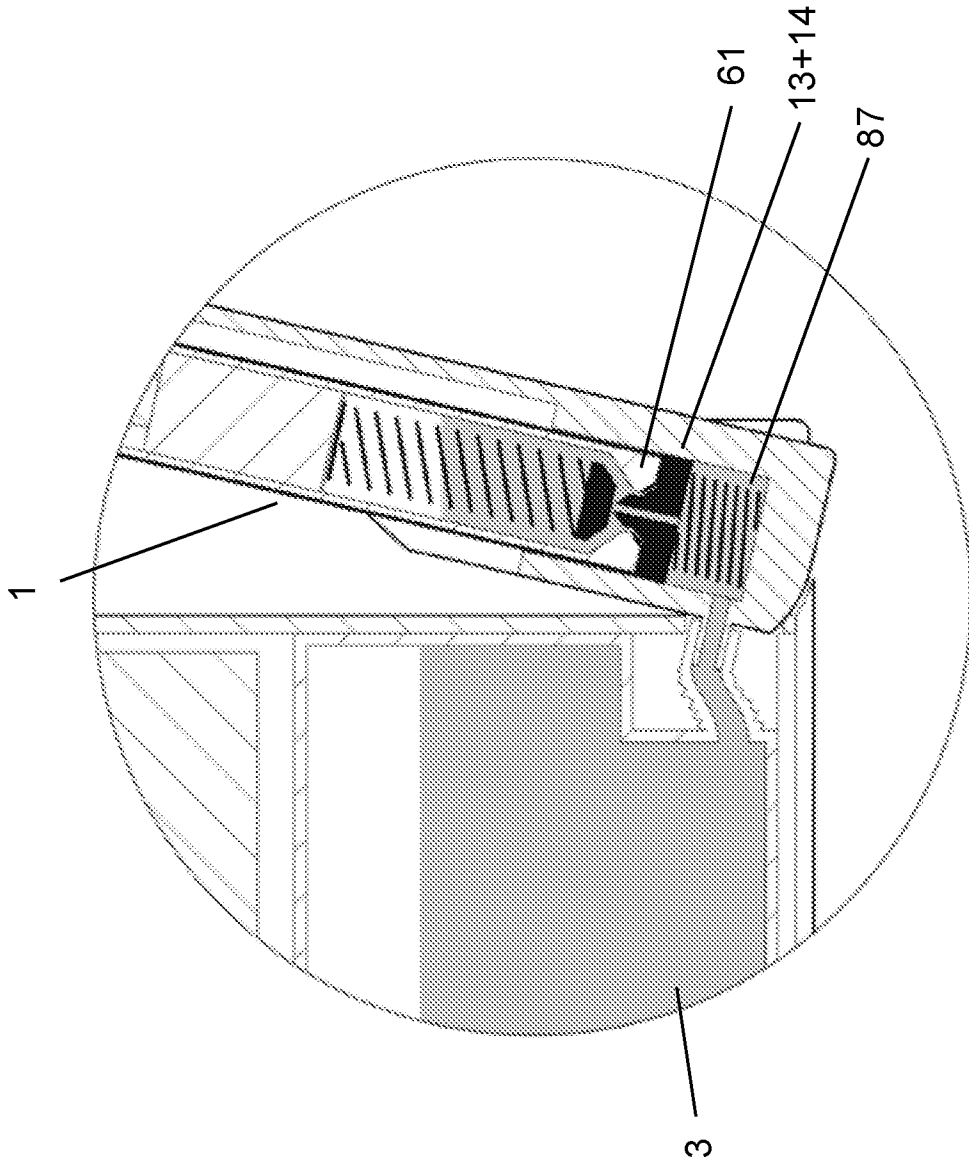

FIGURE 9

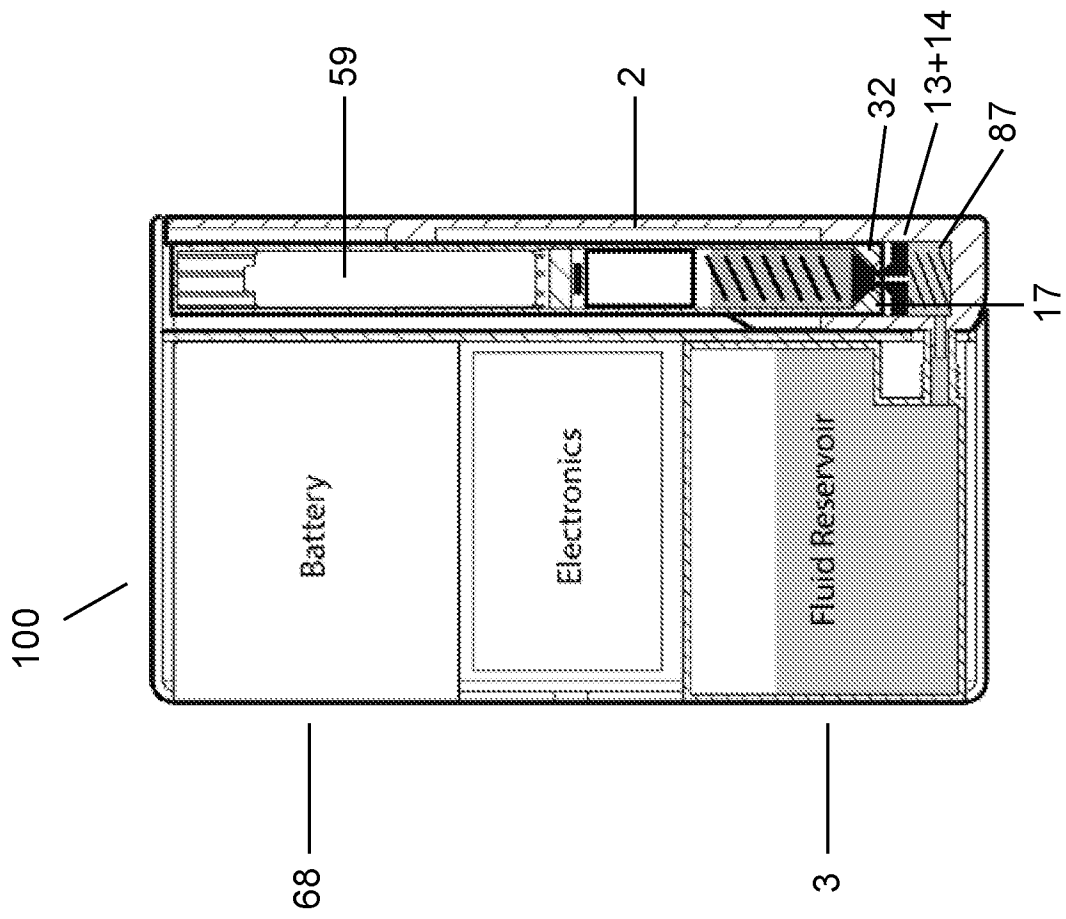

FIGURE 10

11/77

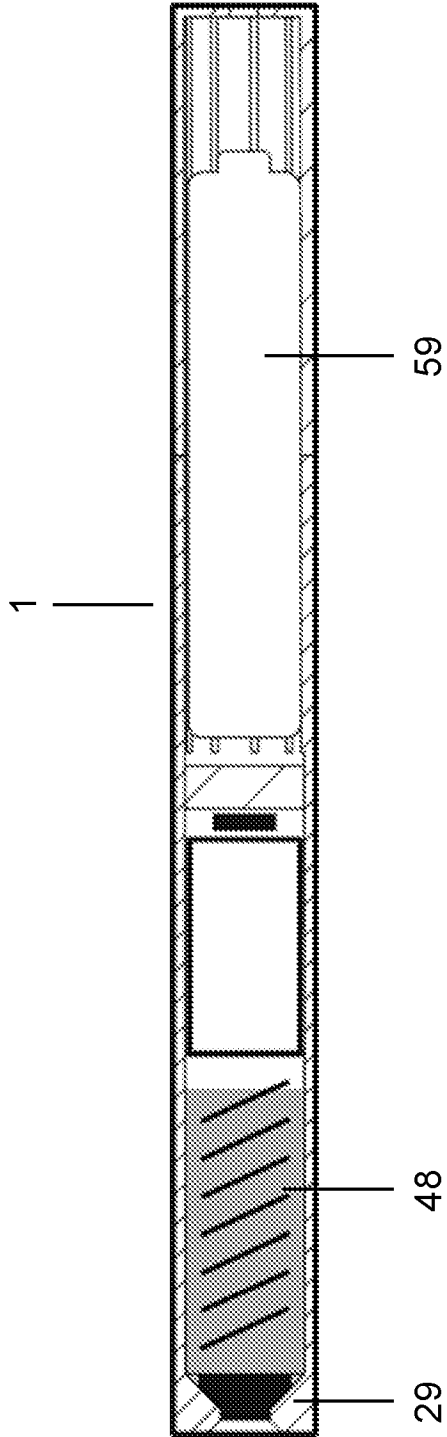

FIGURE 11

12/77

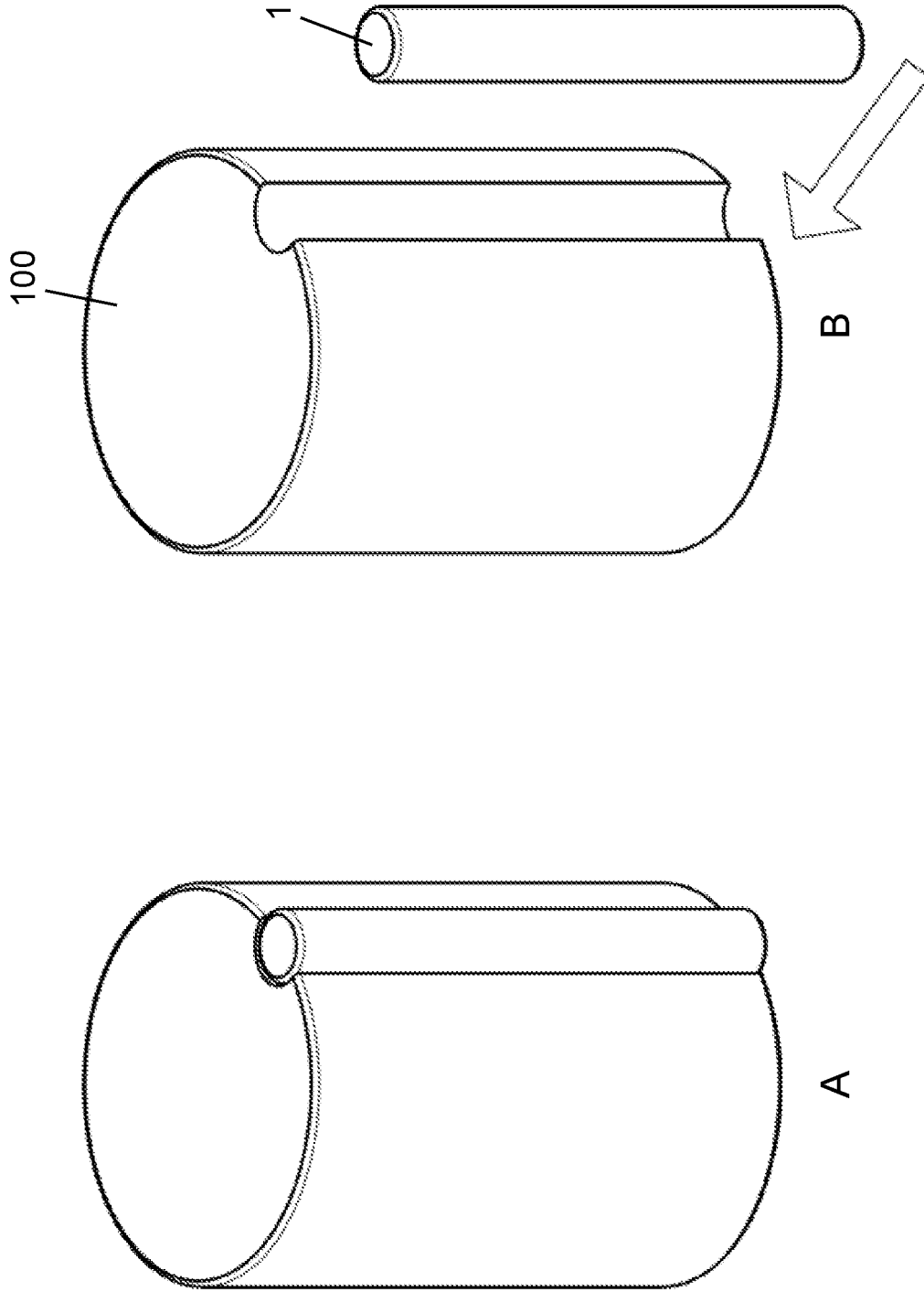

FIGURE 12

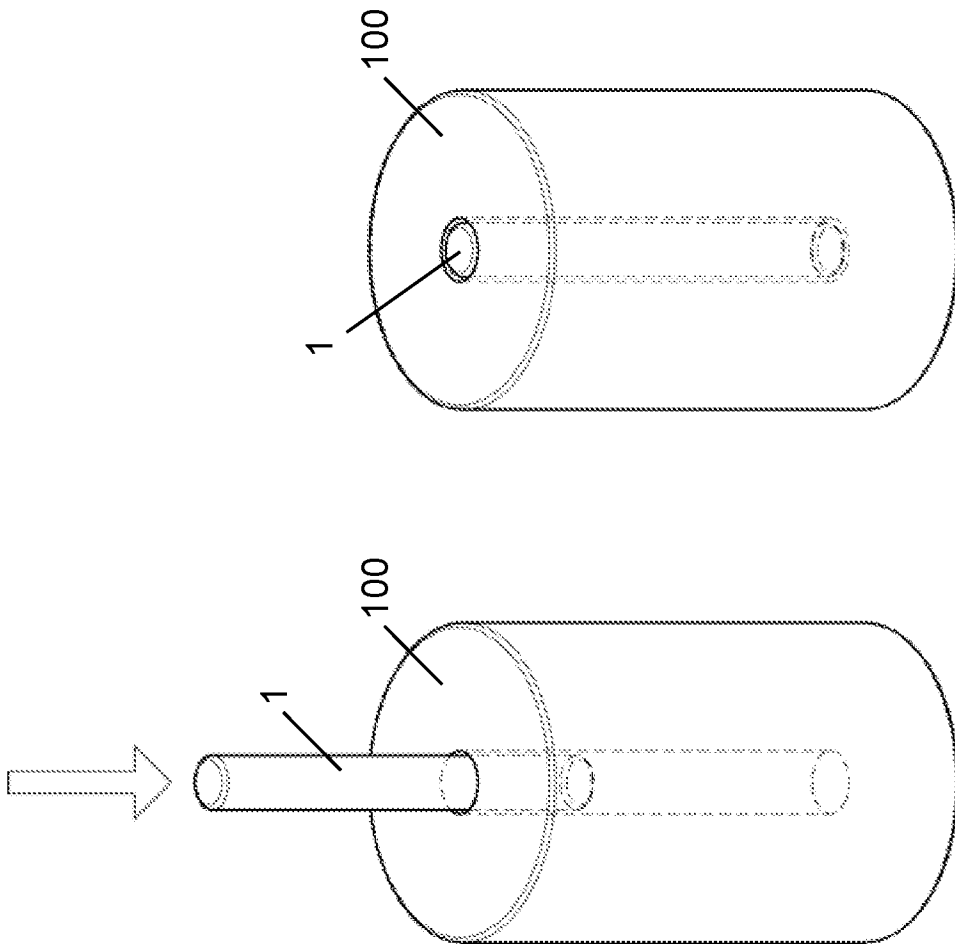

FIGURE 13

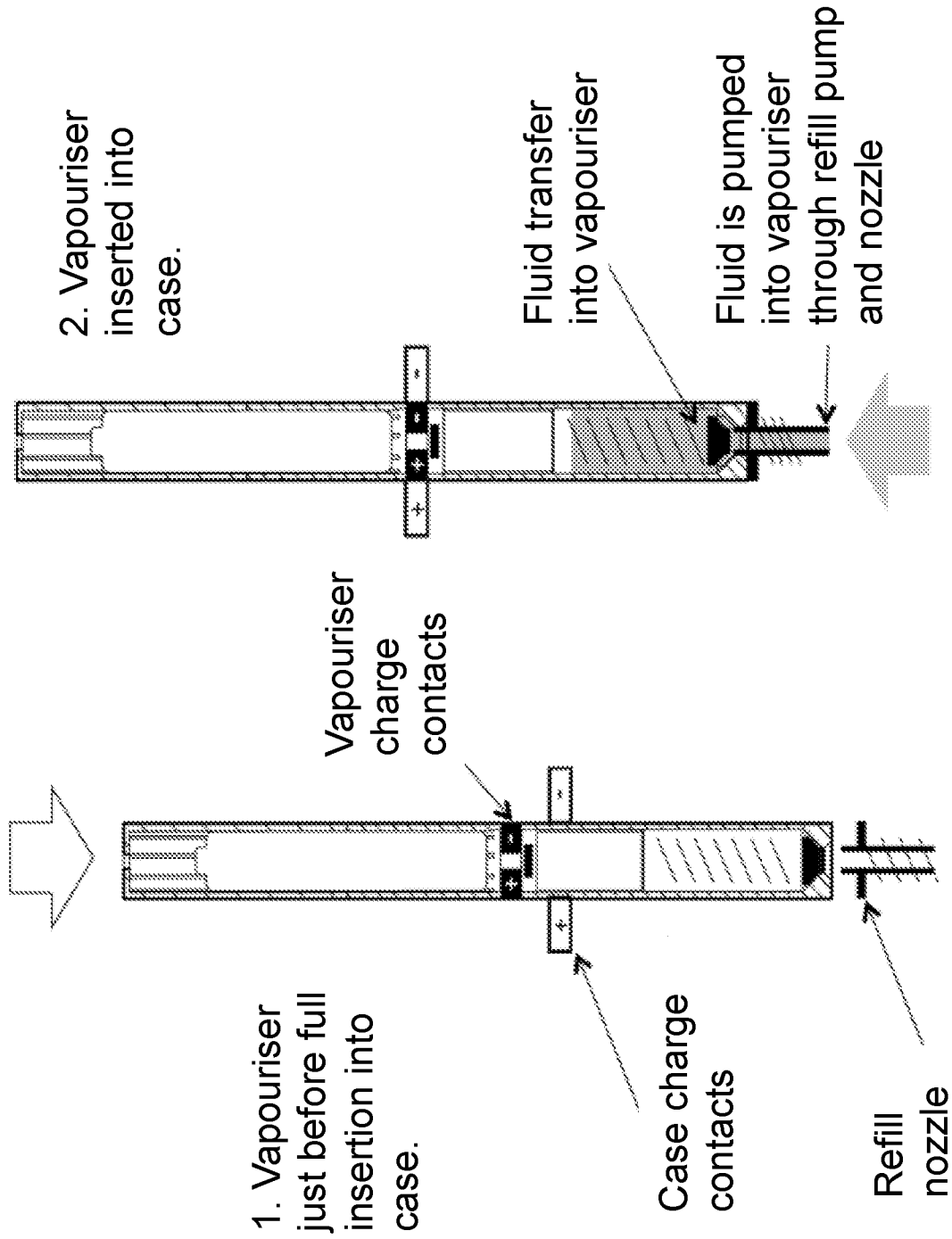

FIGURE 14

15/77

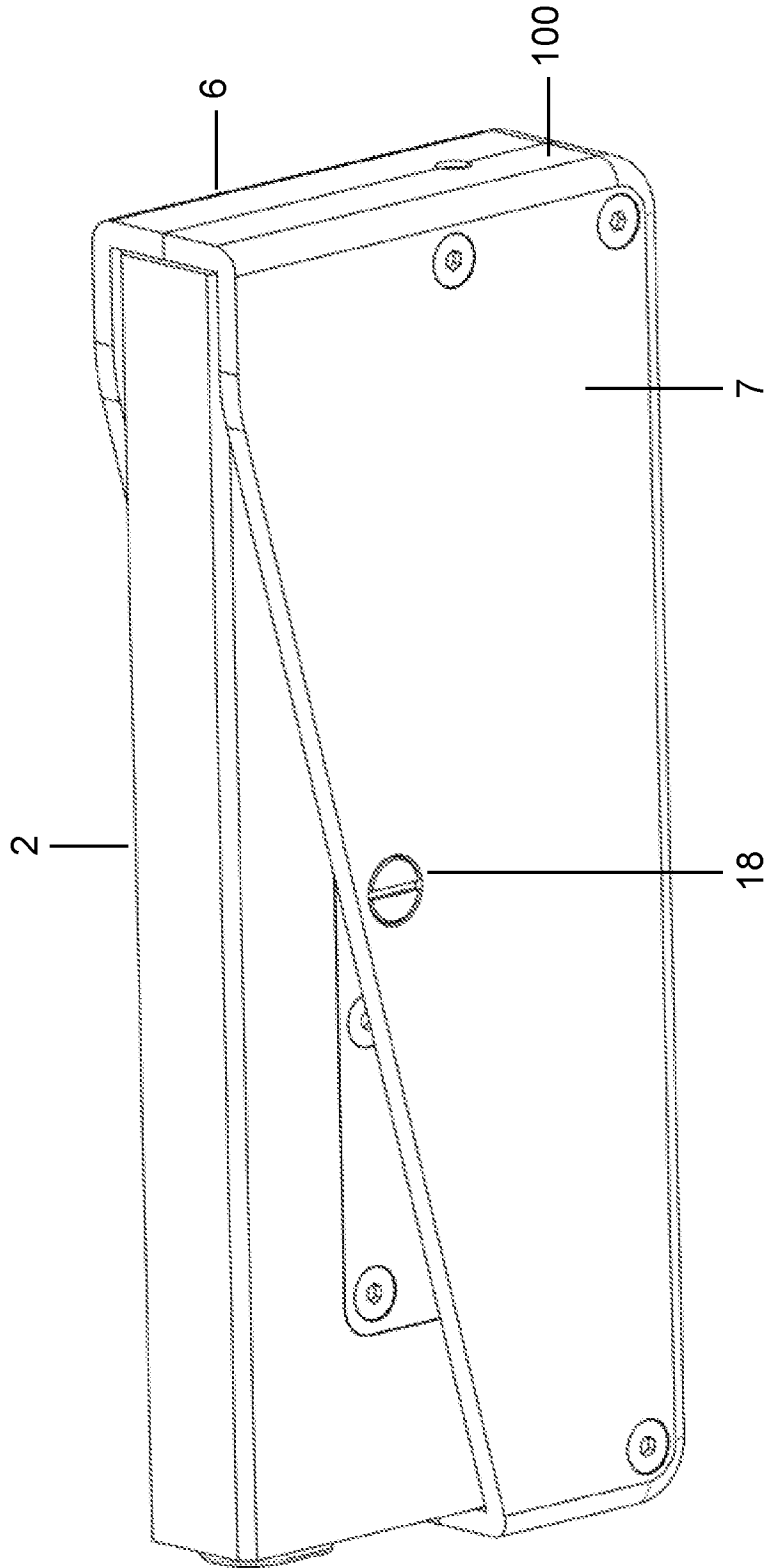

FIGURE 20

16/77

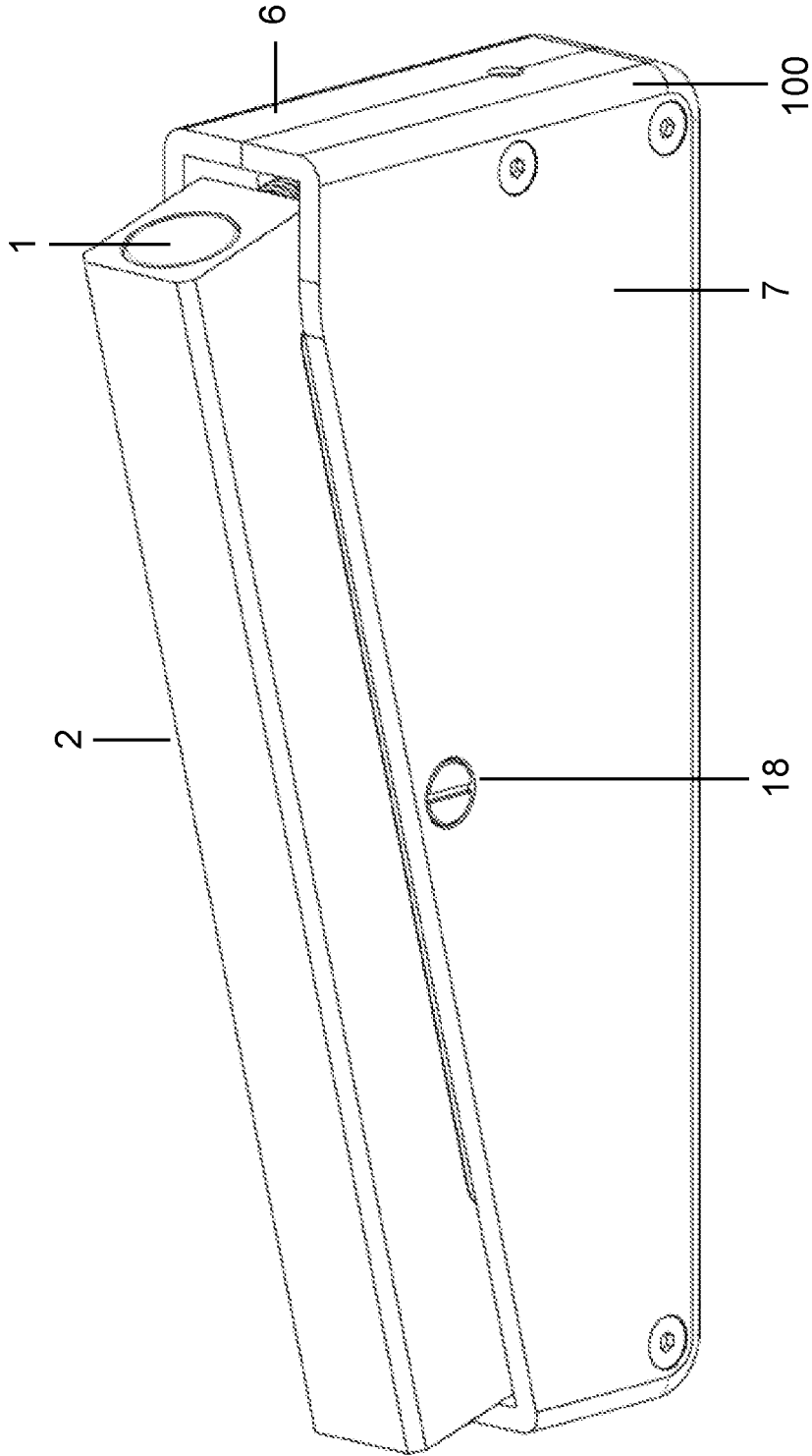

FIGURE 21

17/77

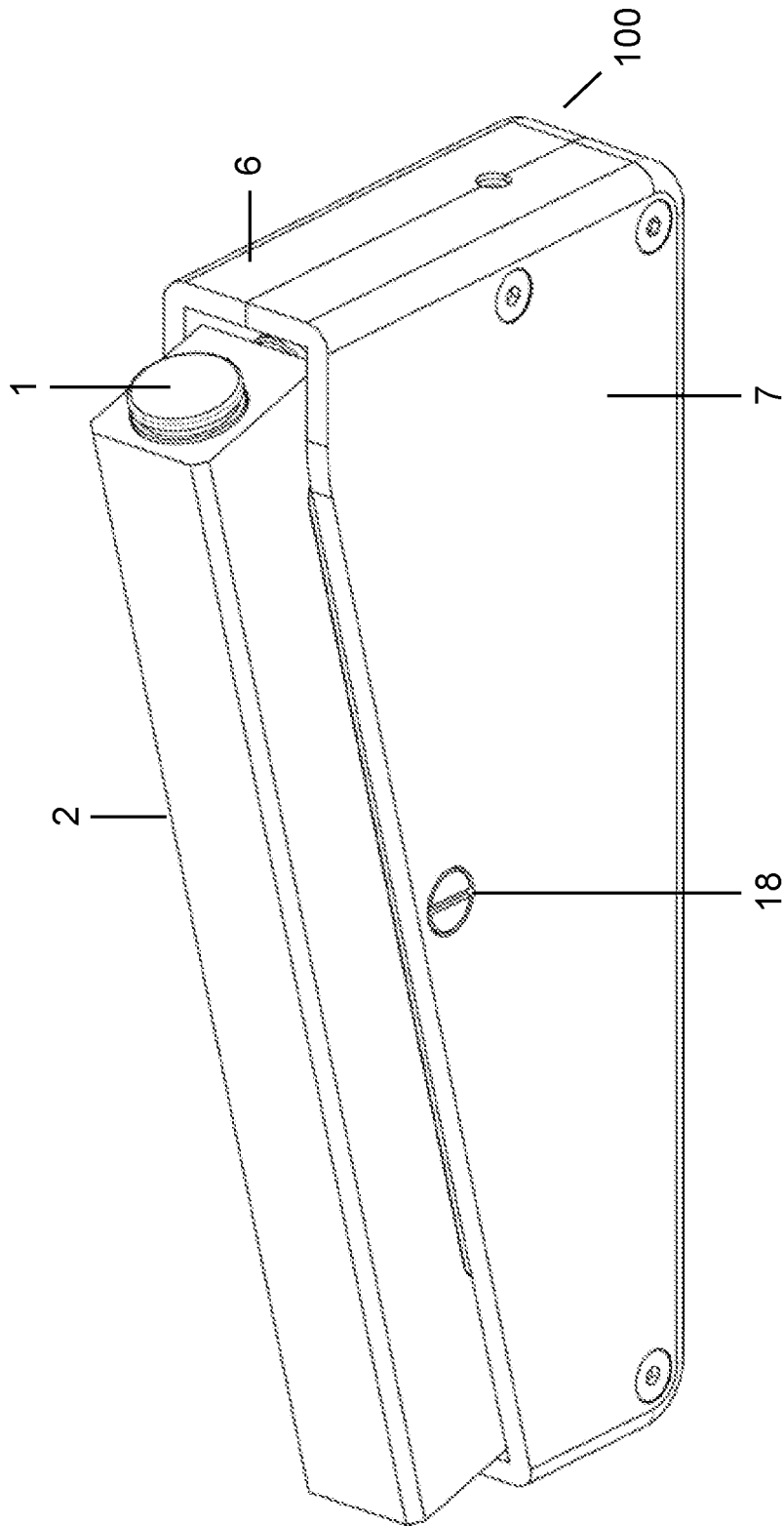

FIGURE 22

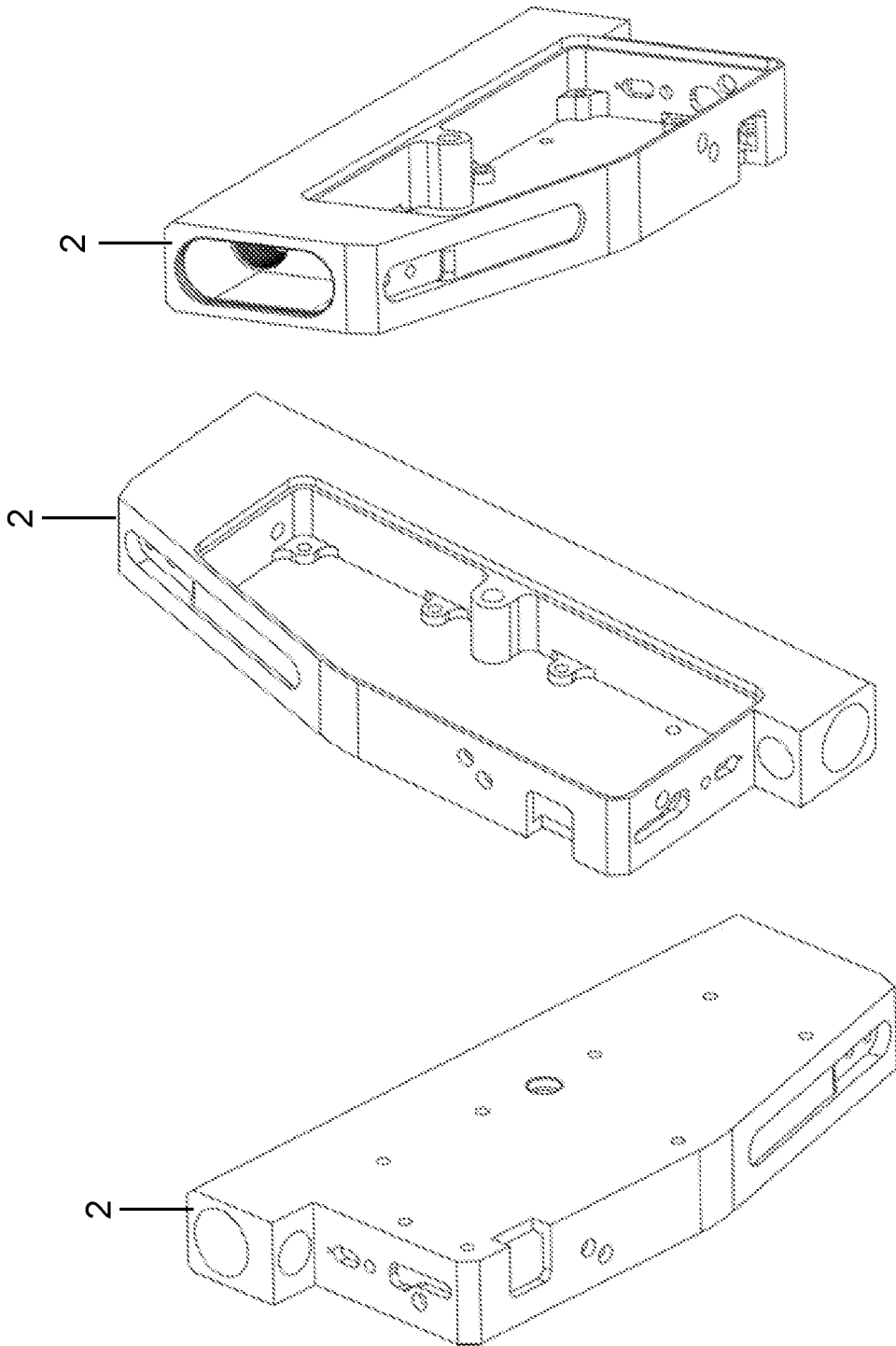

FIGURE 23

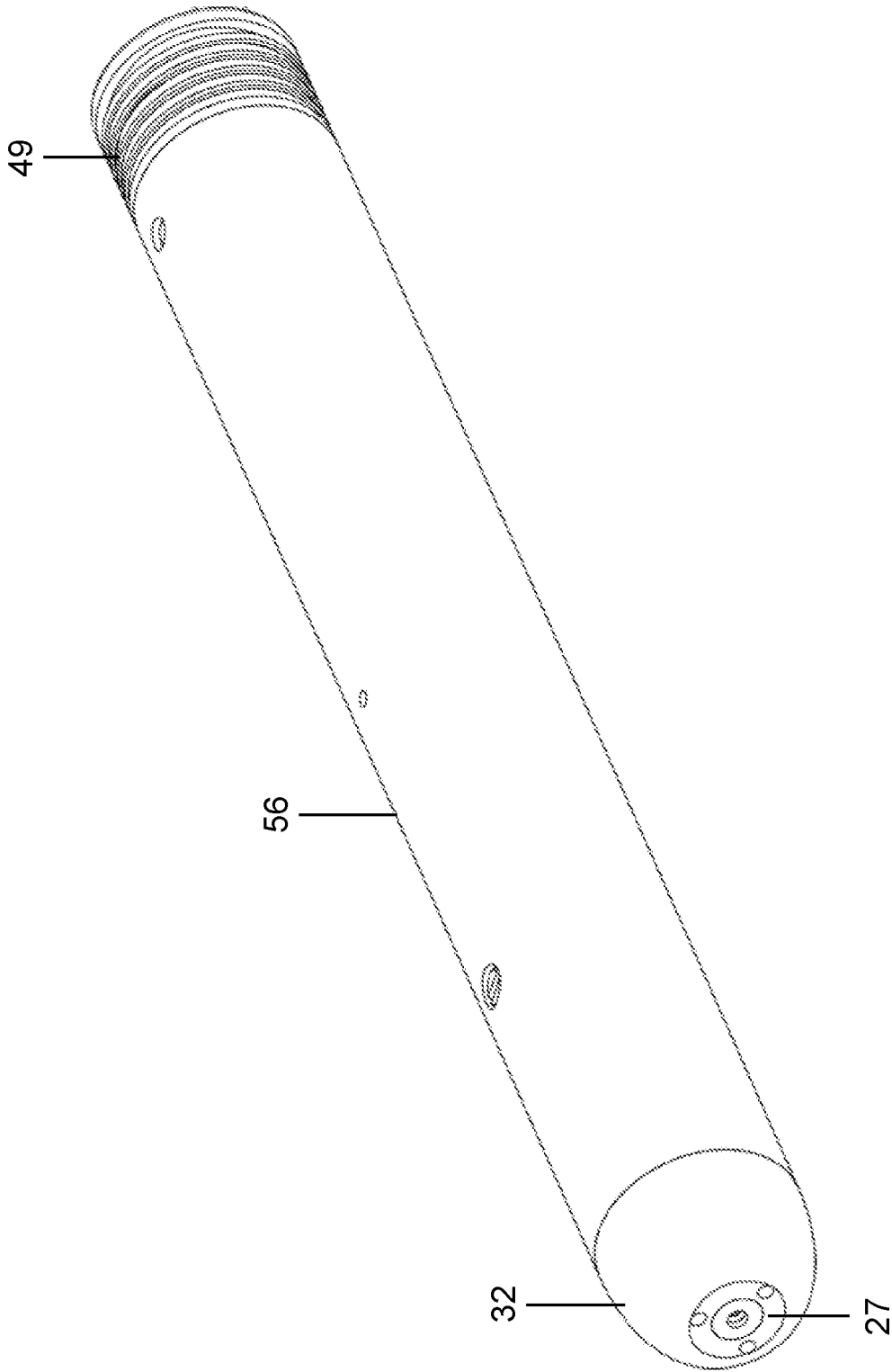

FIGURE 24

20/77

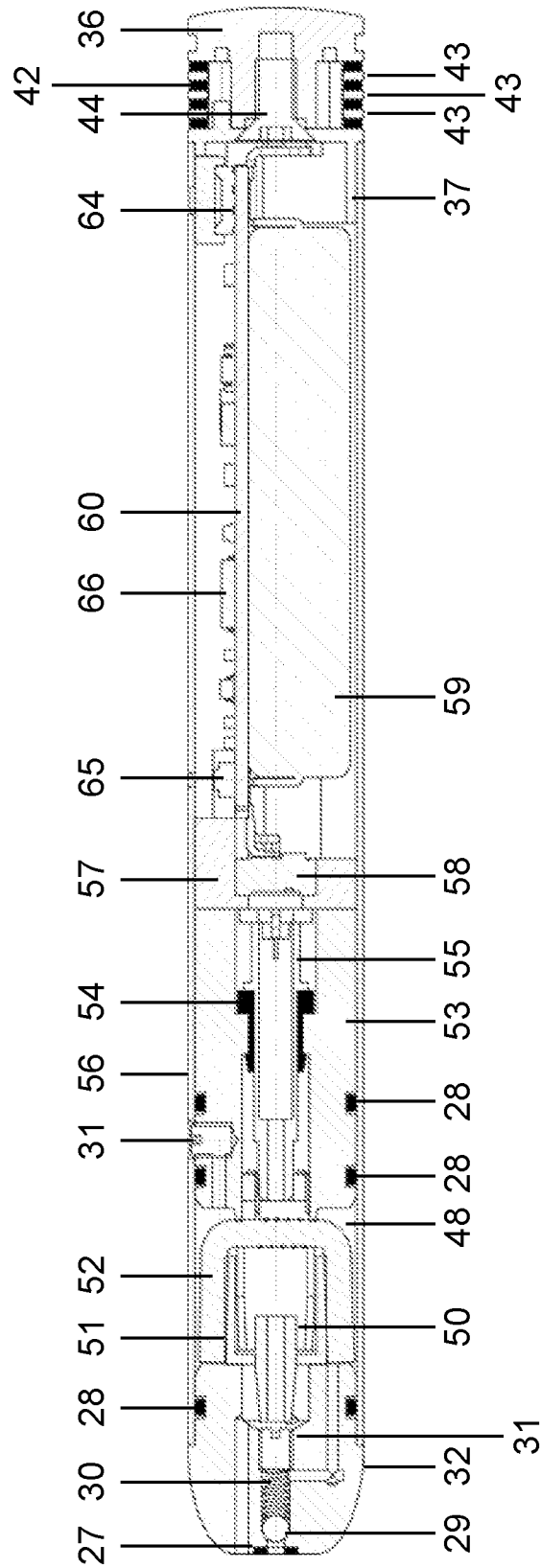

FIGURE 25

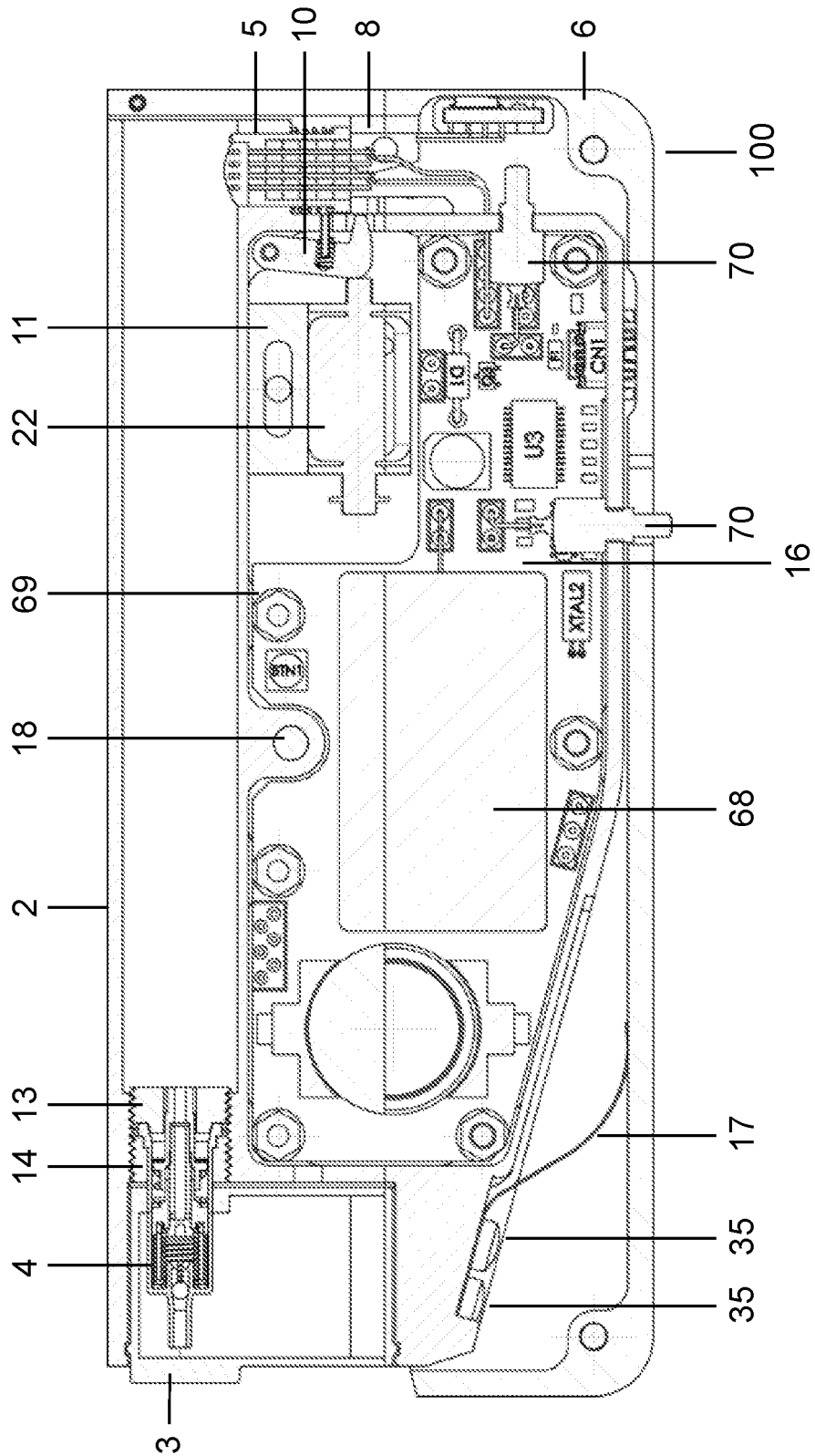

FIGURE 26

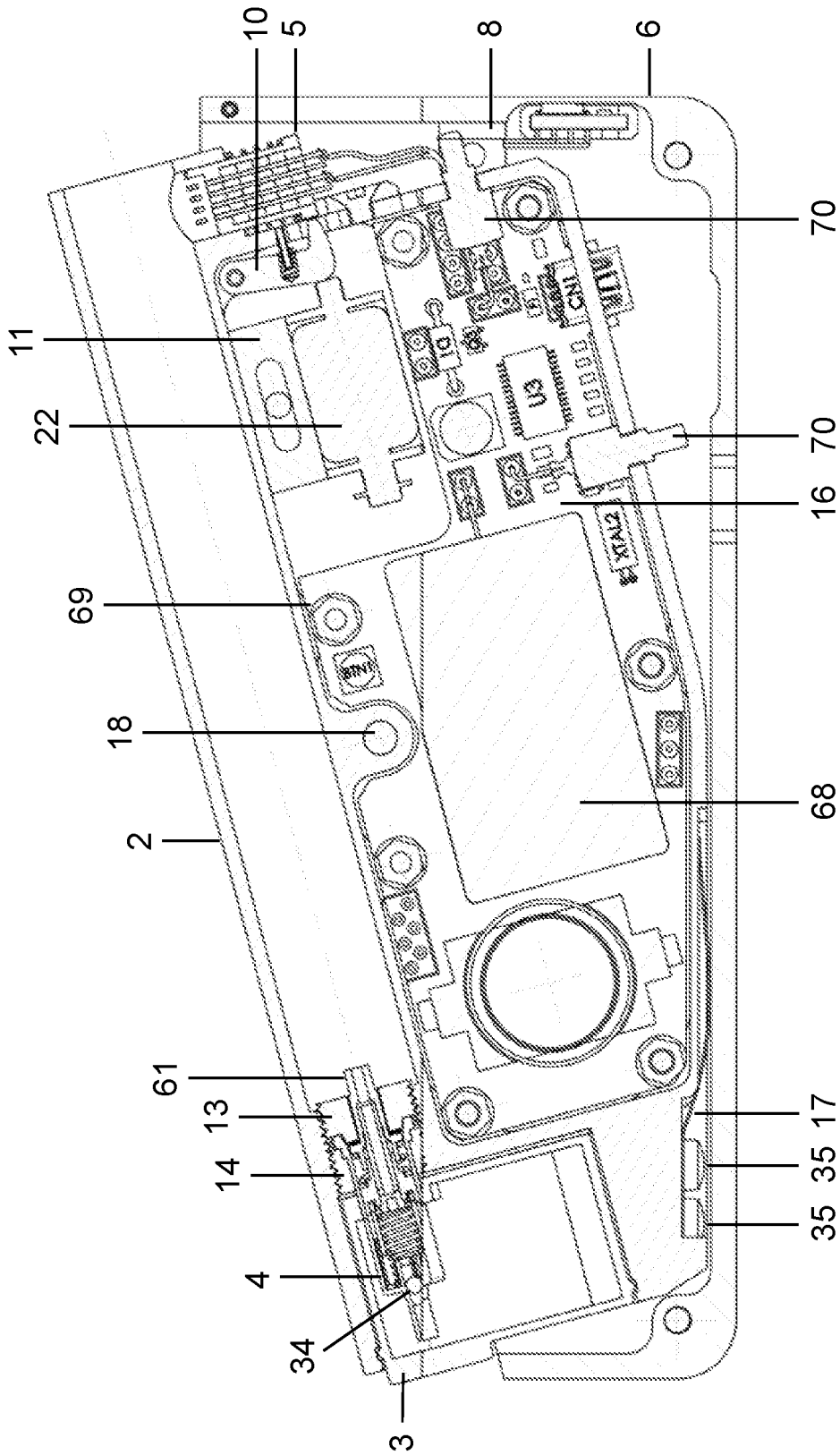

FIGURE 27

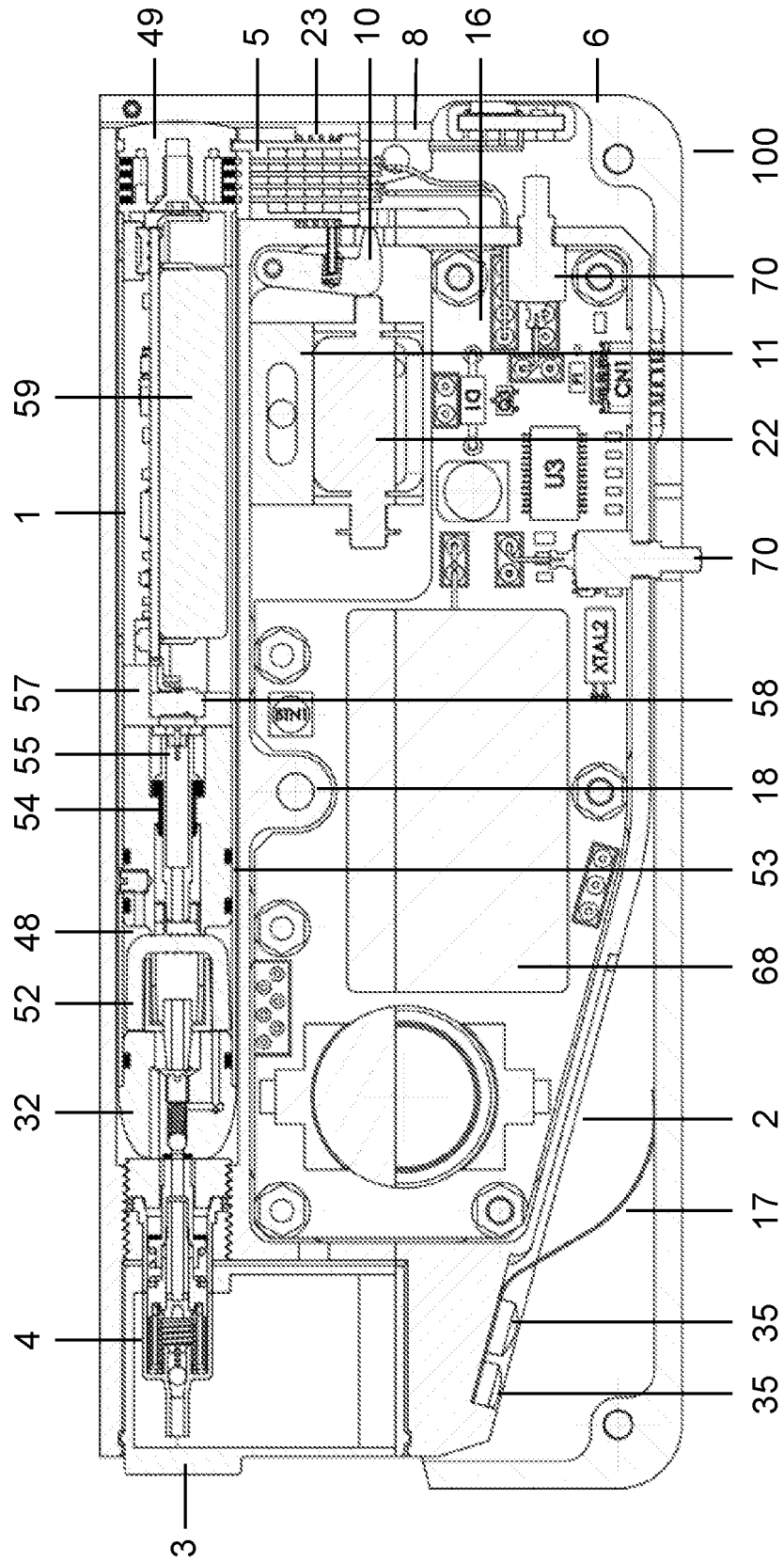

FIGURE 28

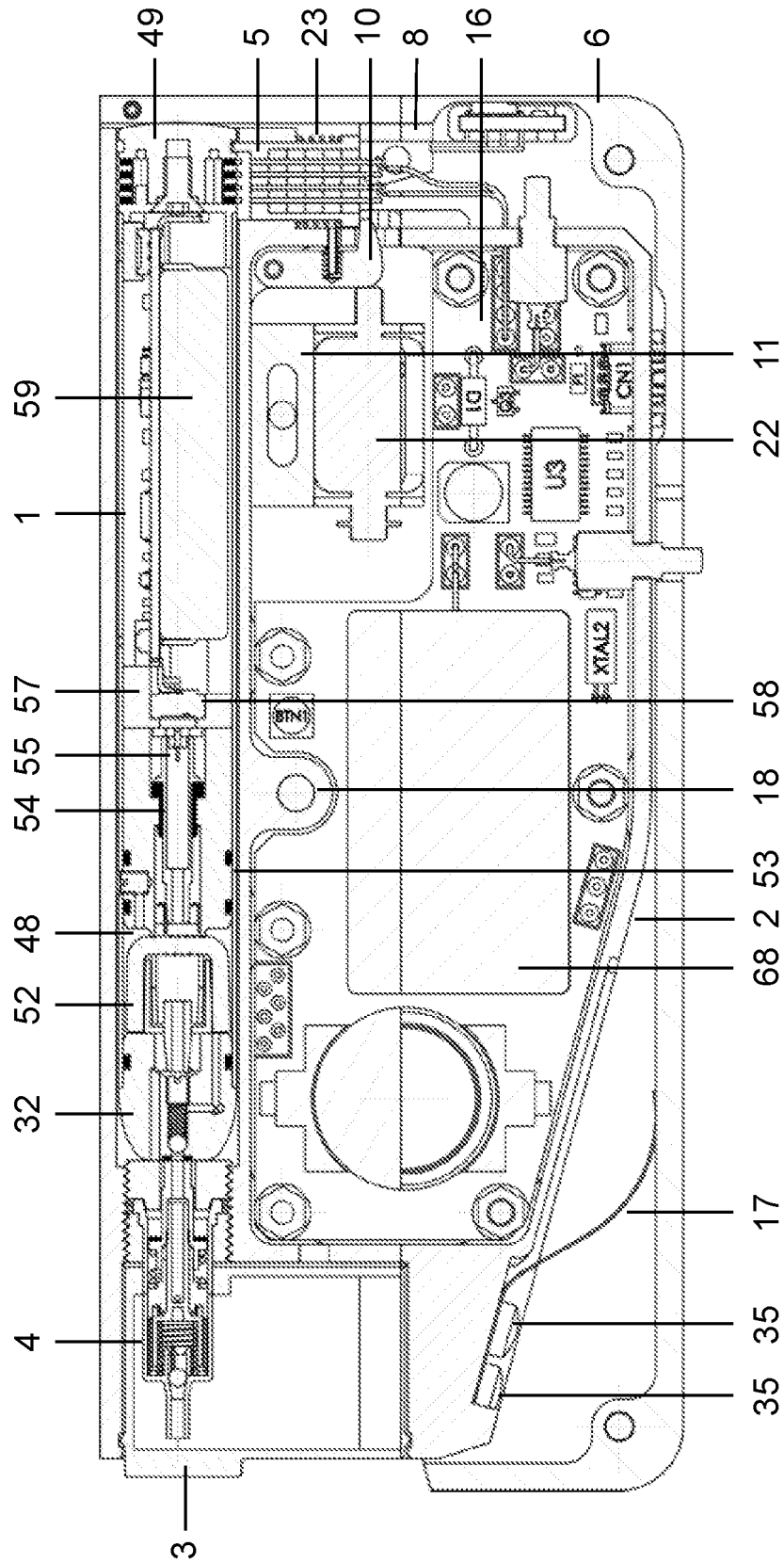

FIGURE 29

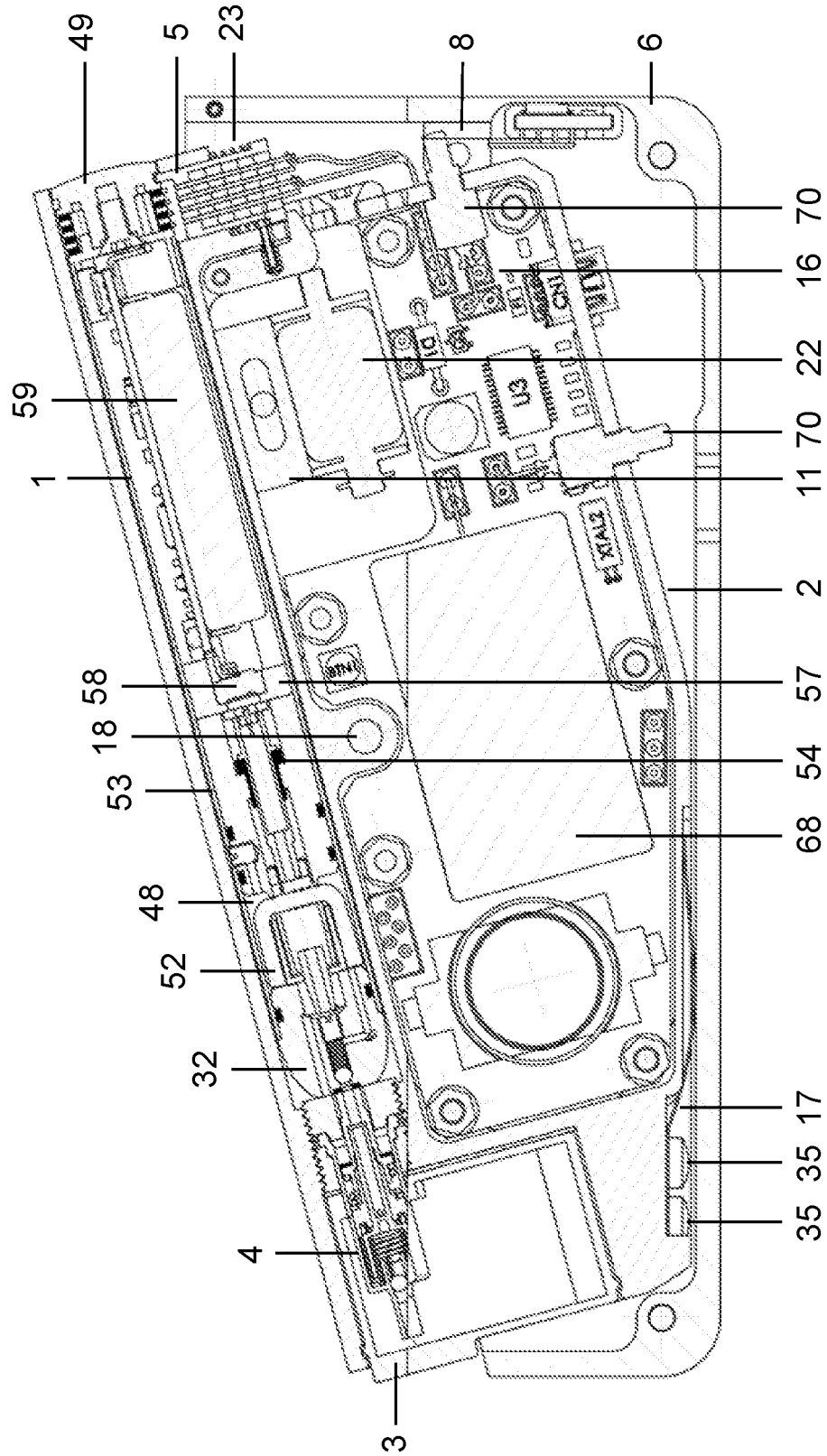

FIGURE 30

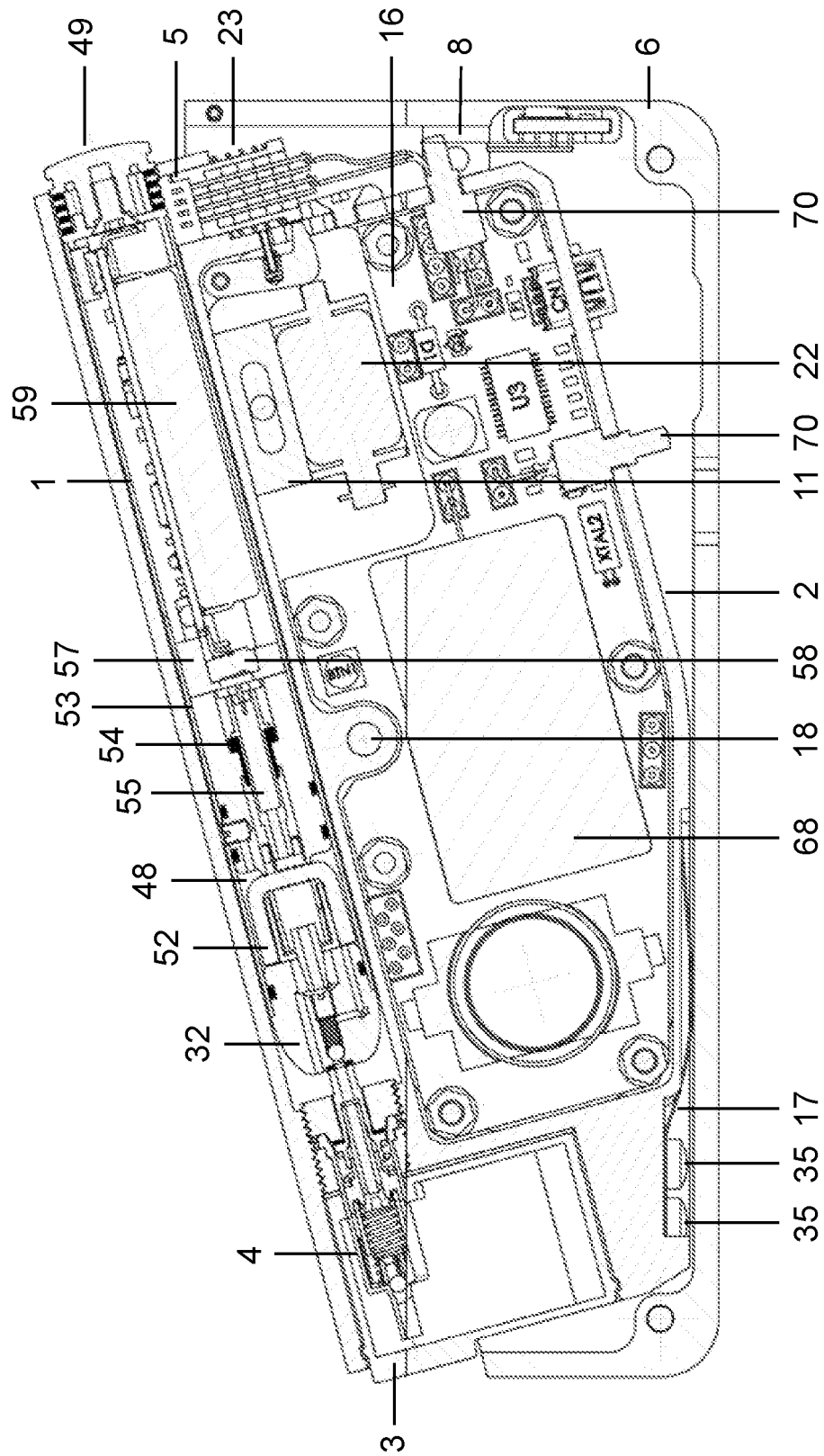

FIGURE 31

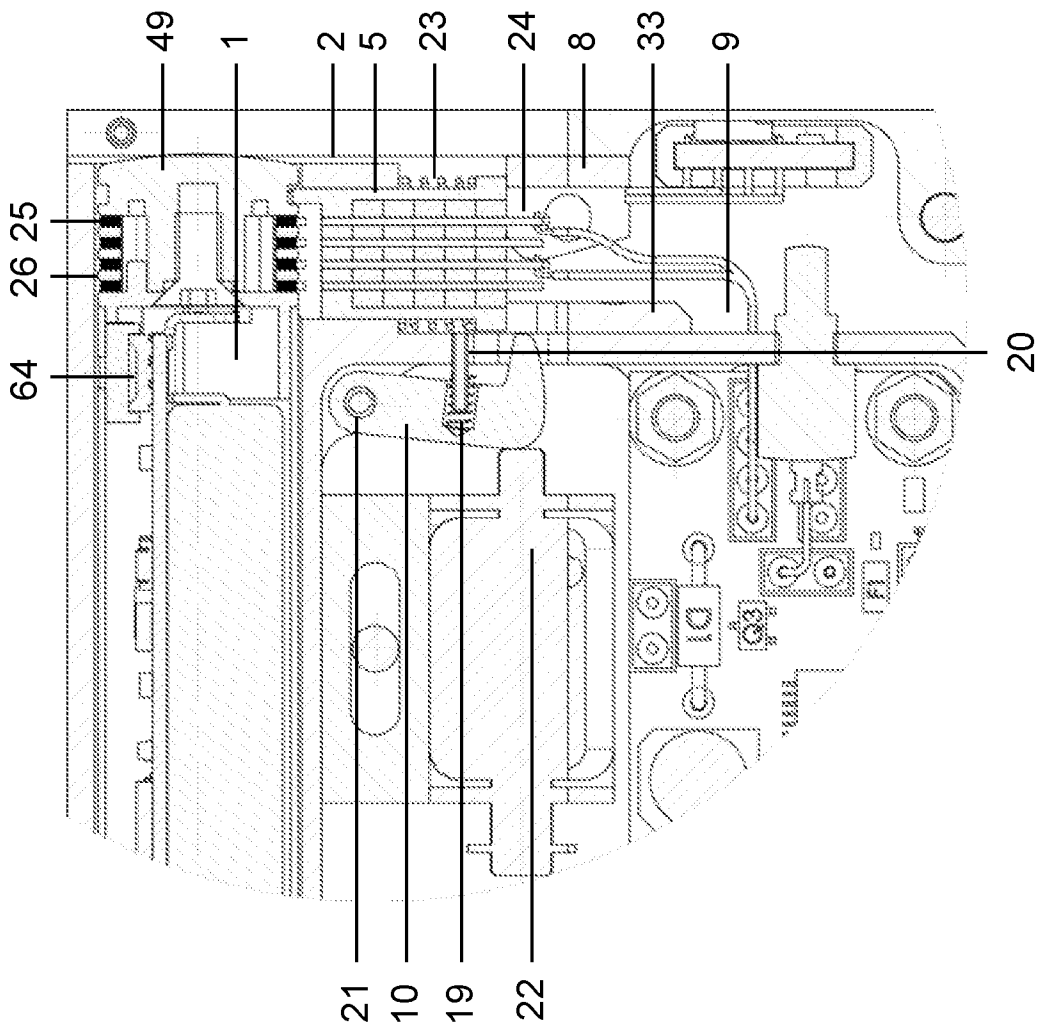

FIGURE 32

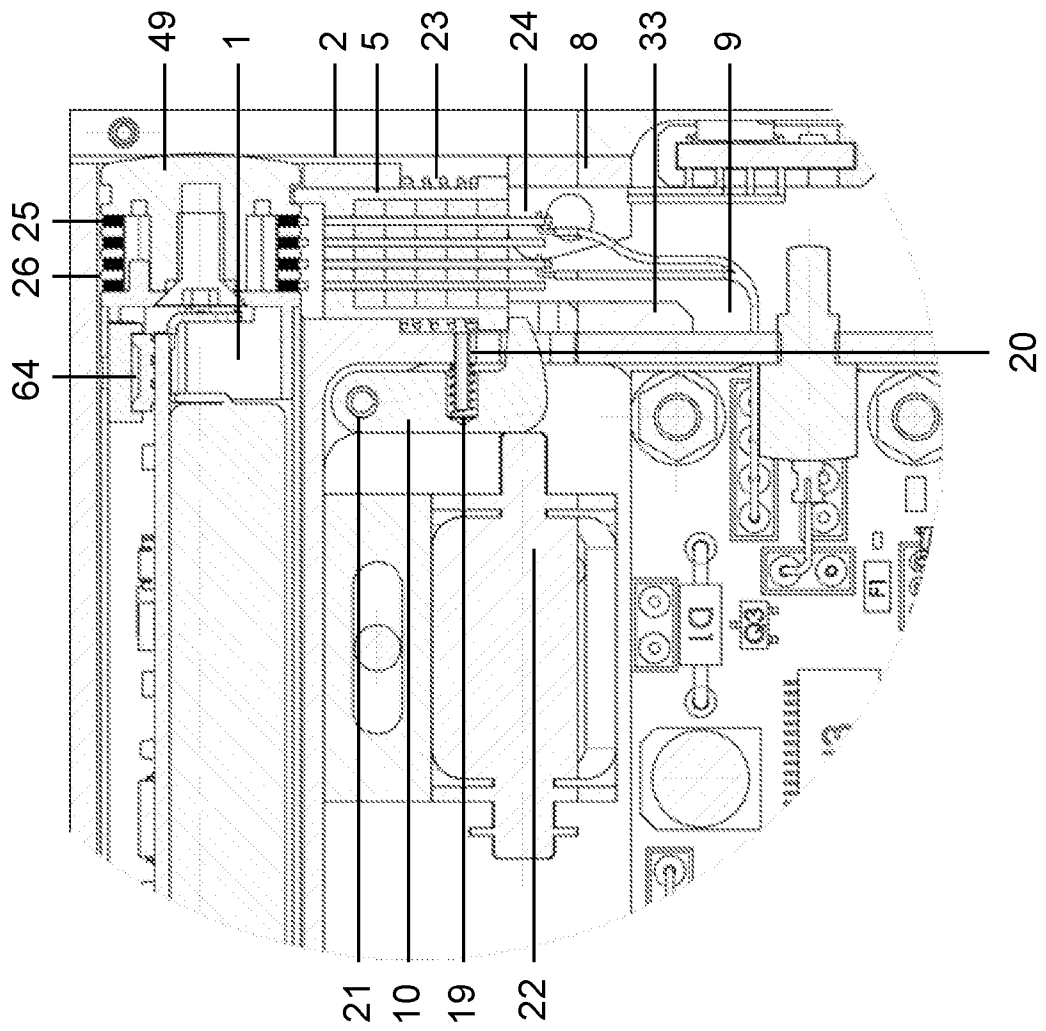

FIGURE 33

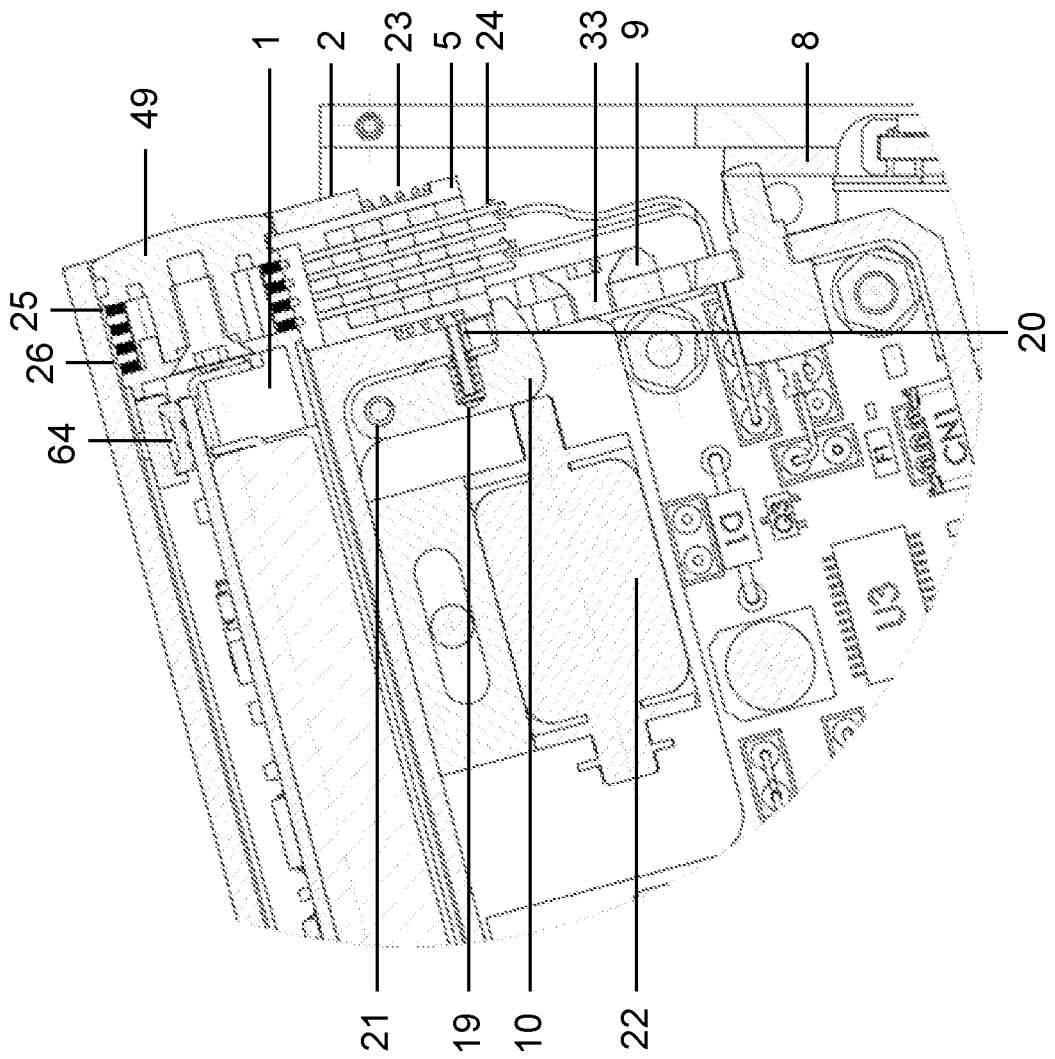

FIGURE 34

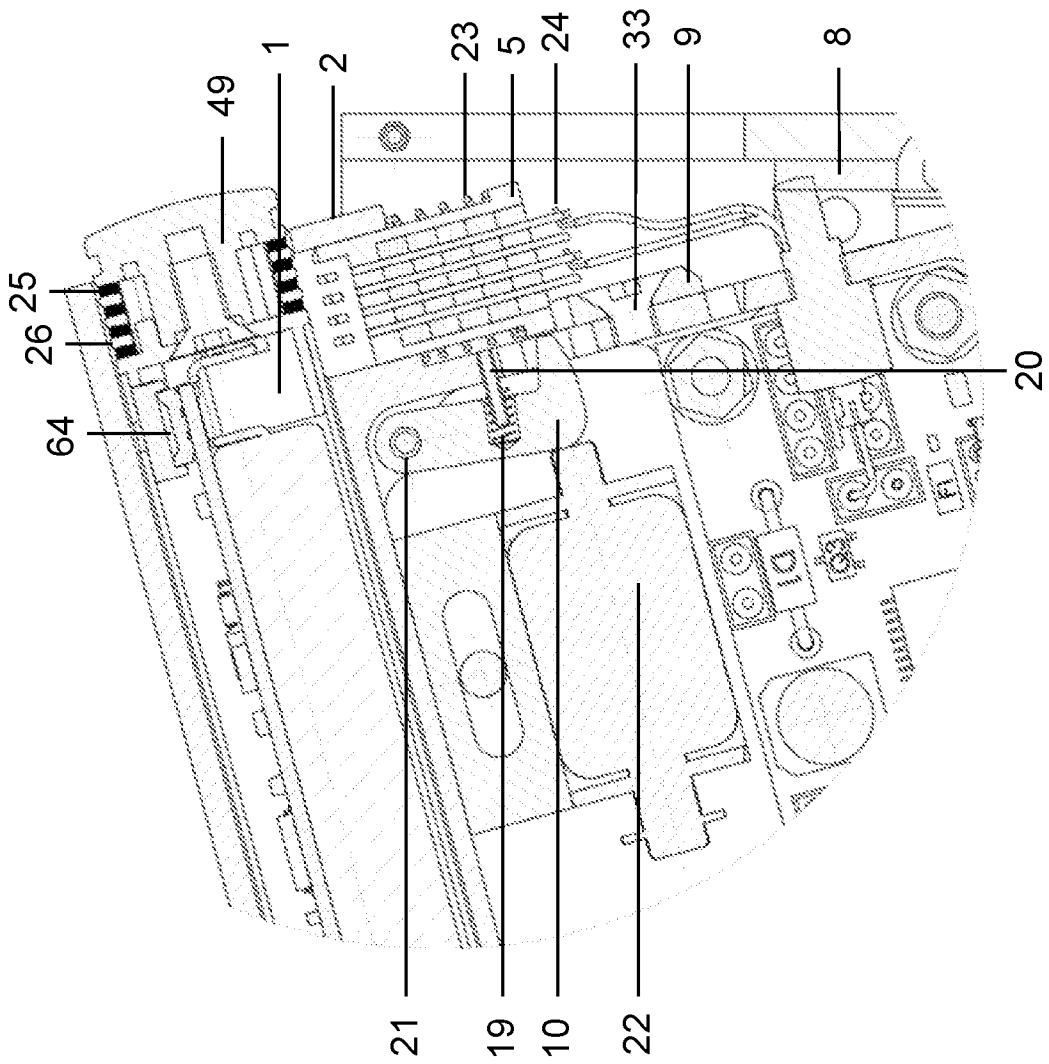

FIGURE 35

31/77

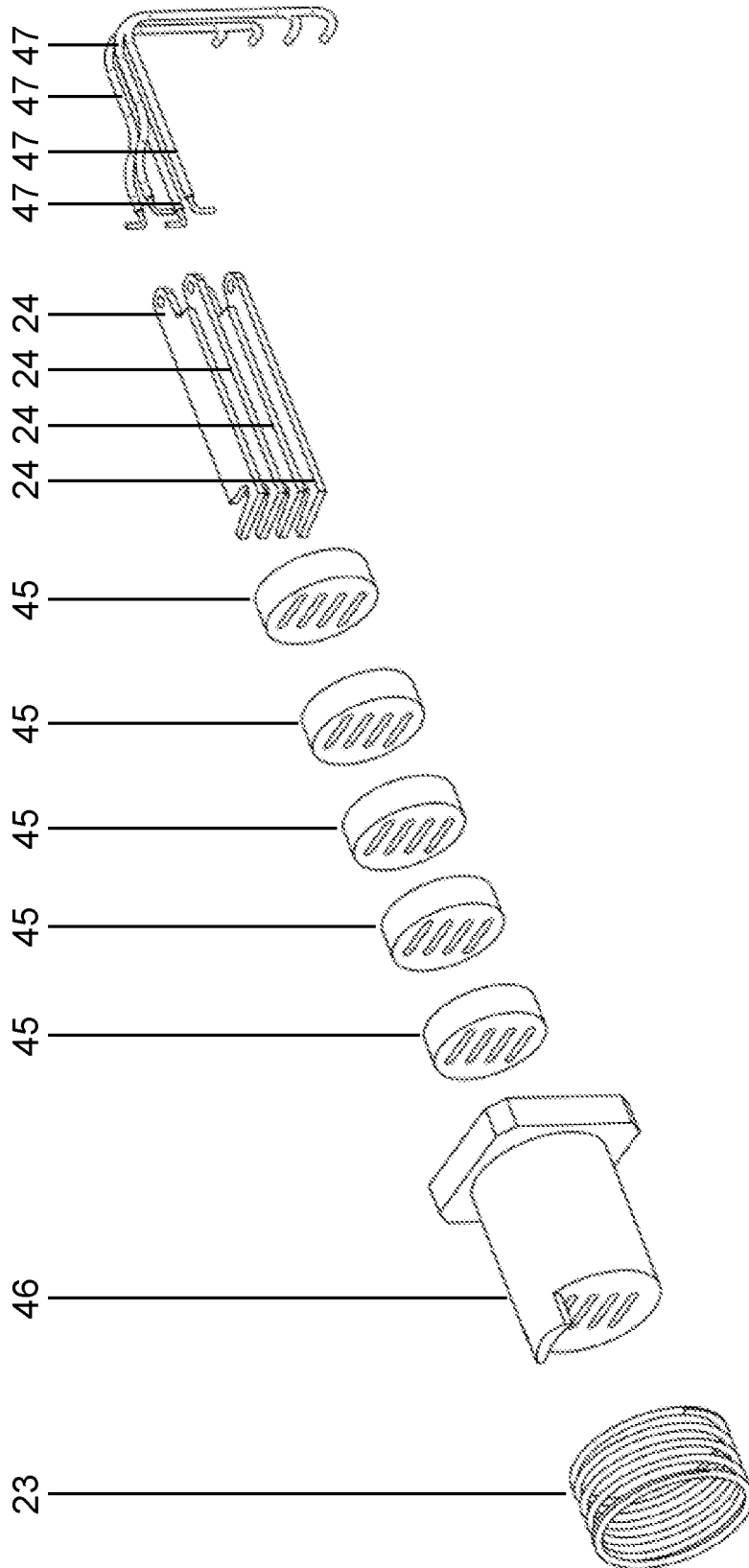

FIGURE 36

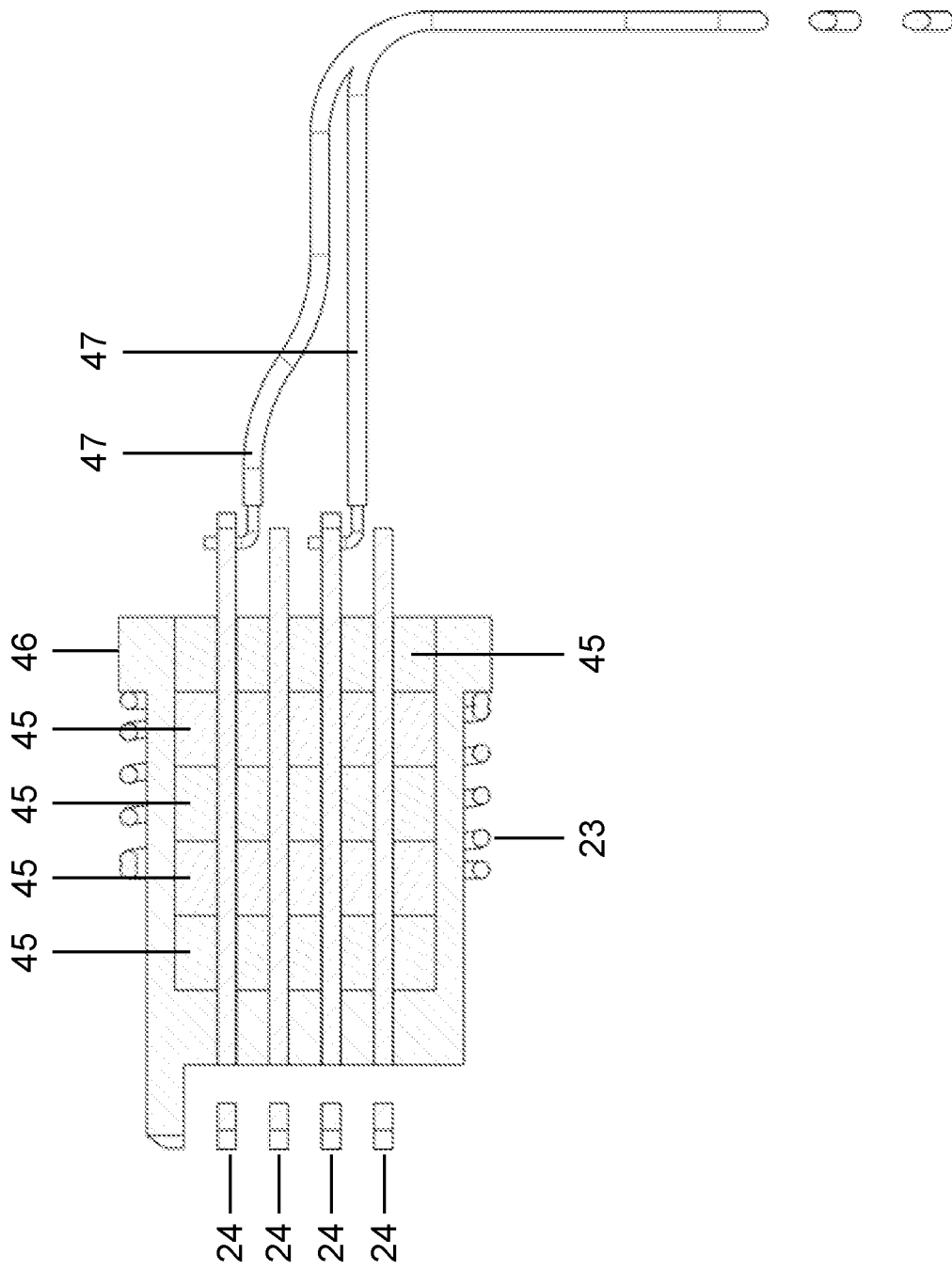

FIGURE 37A

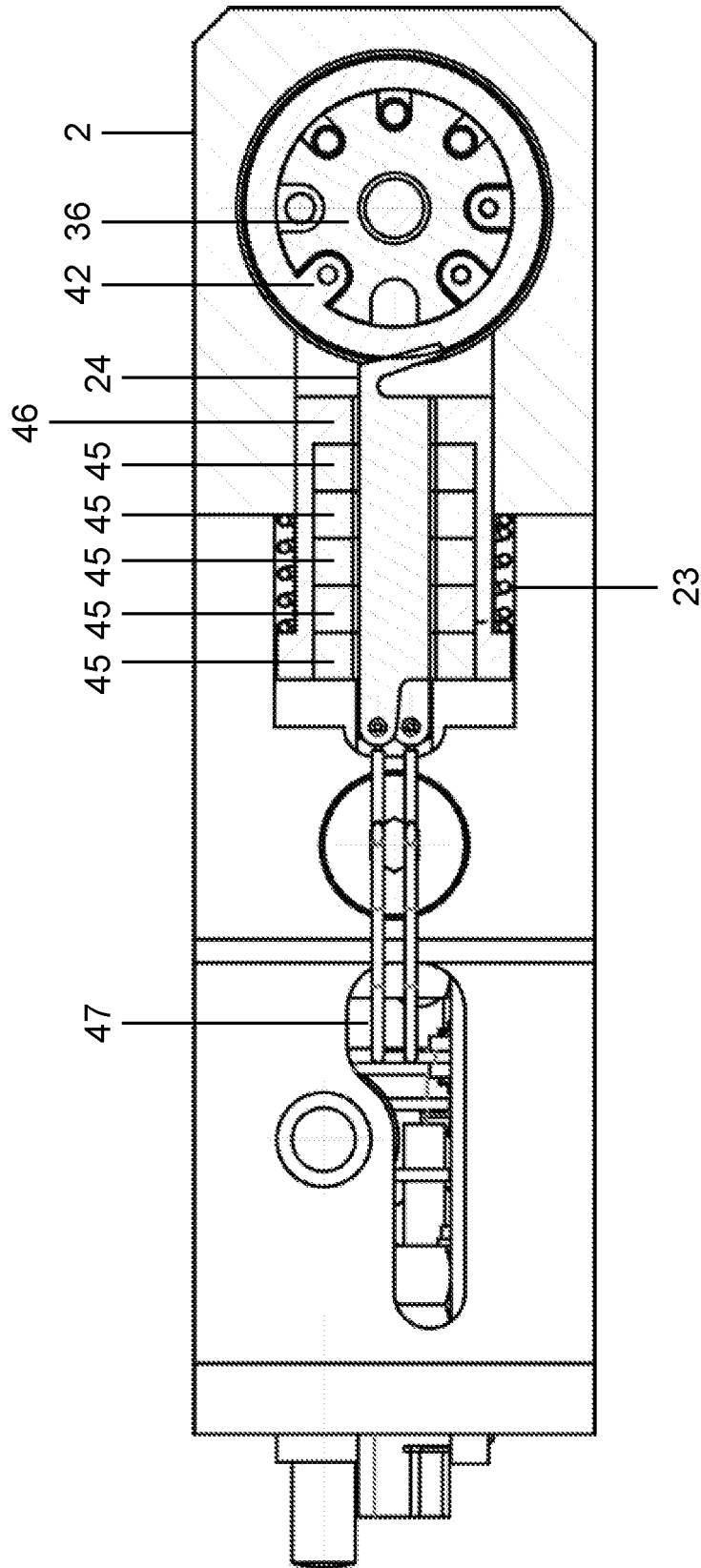

FIGURE 37B

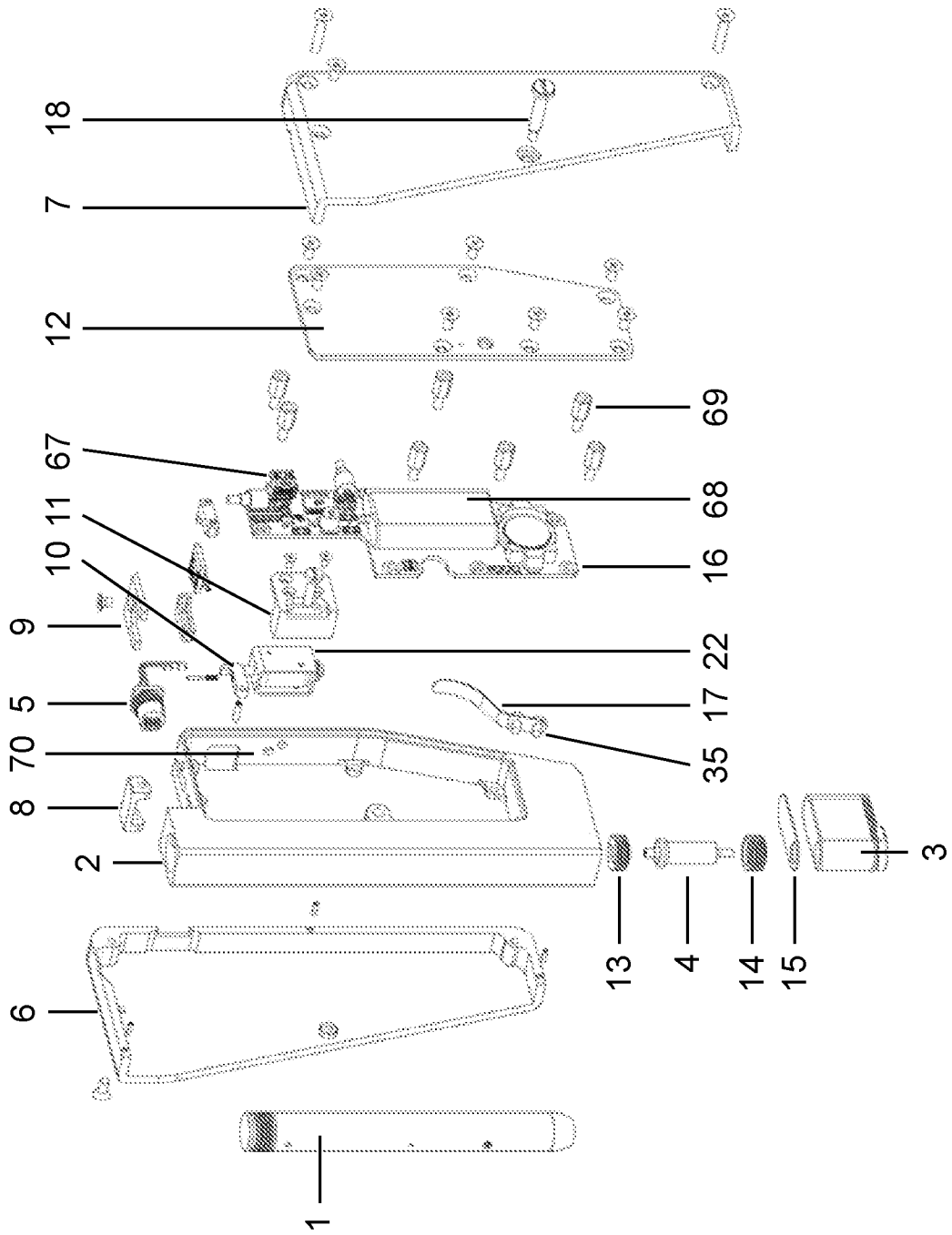

FIGURE 38

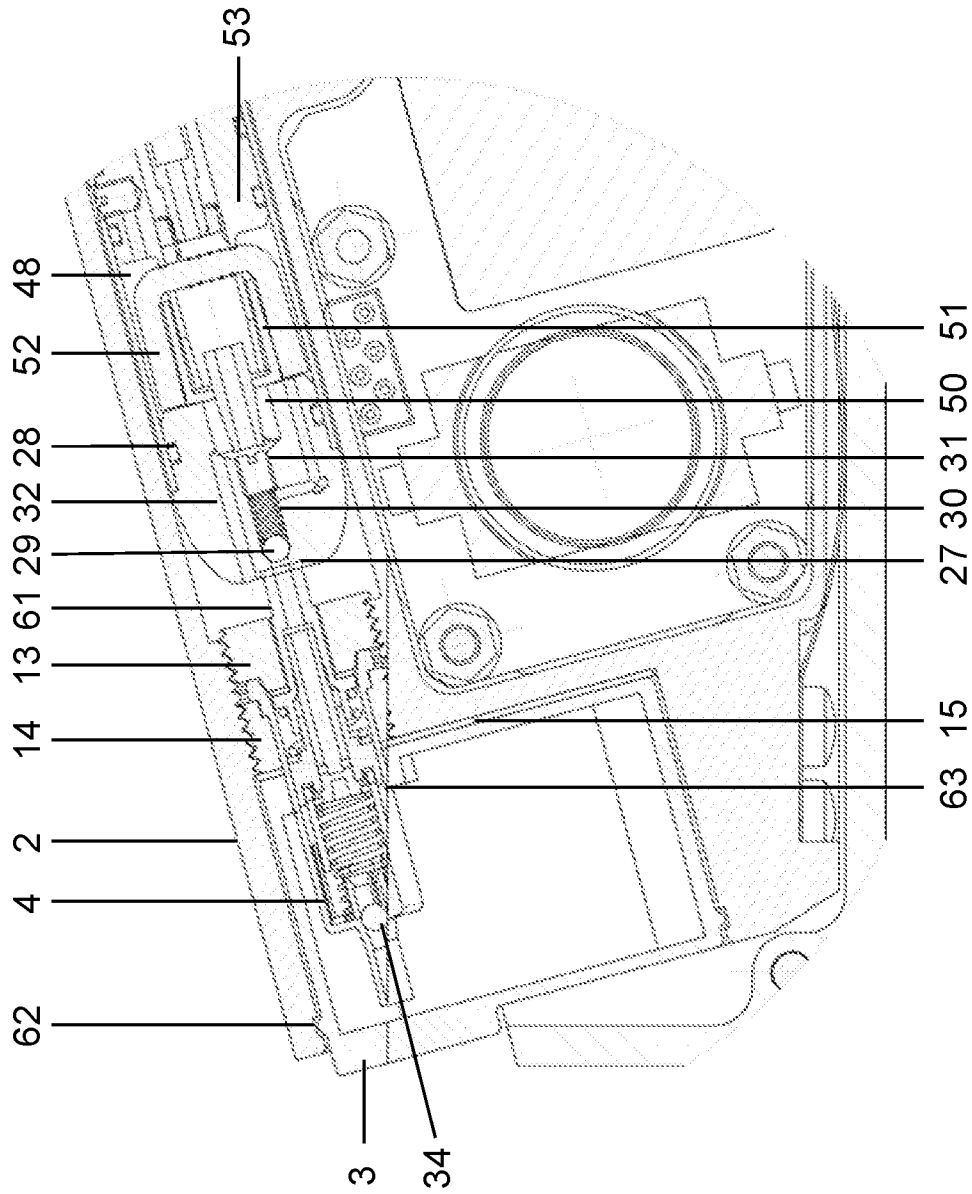

FIGURE 40

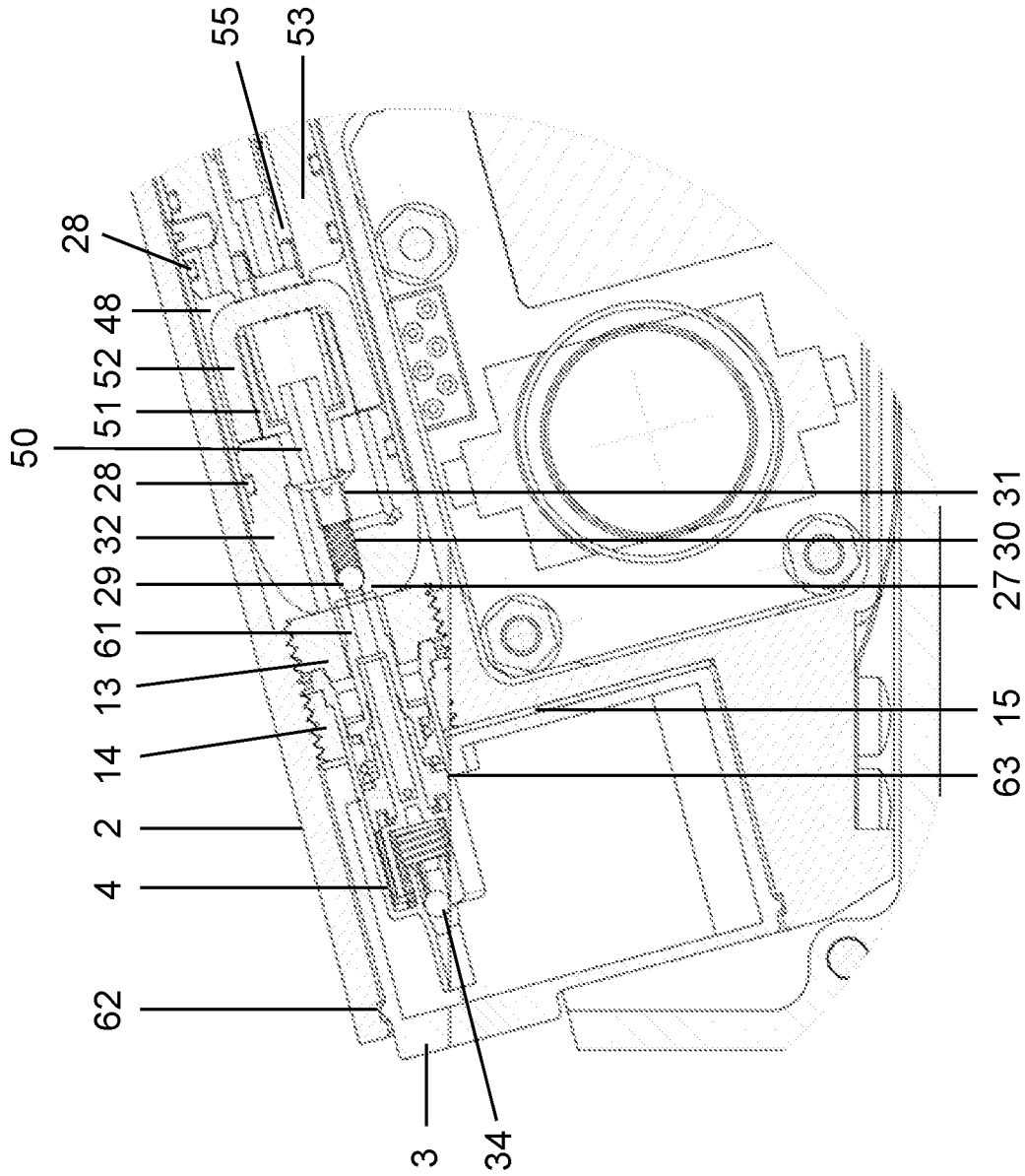

FIGURE 41

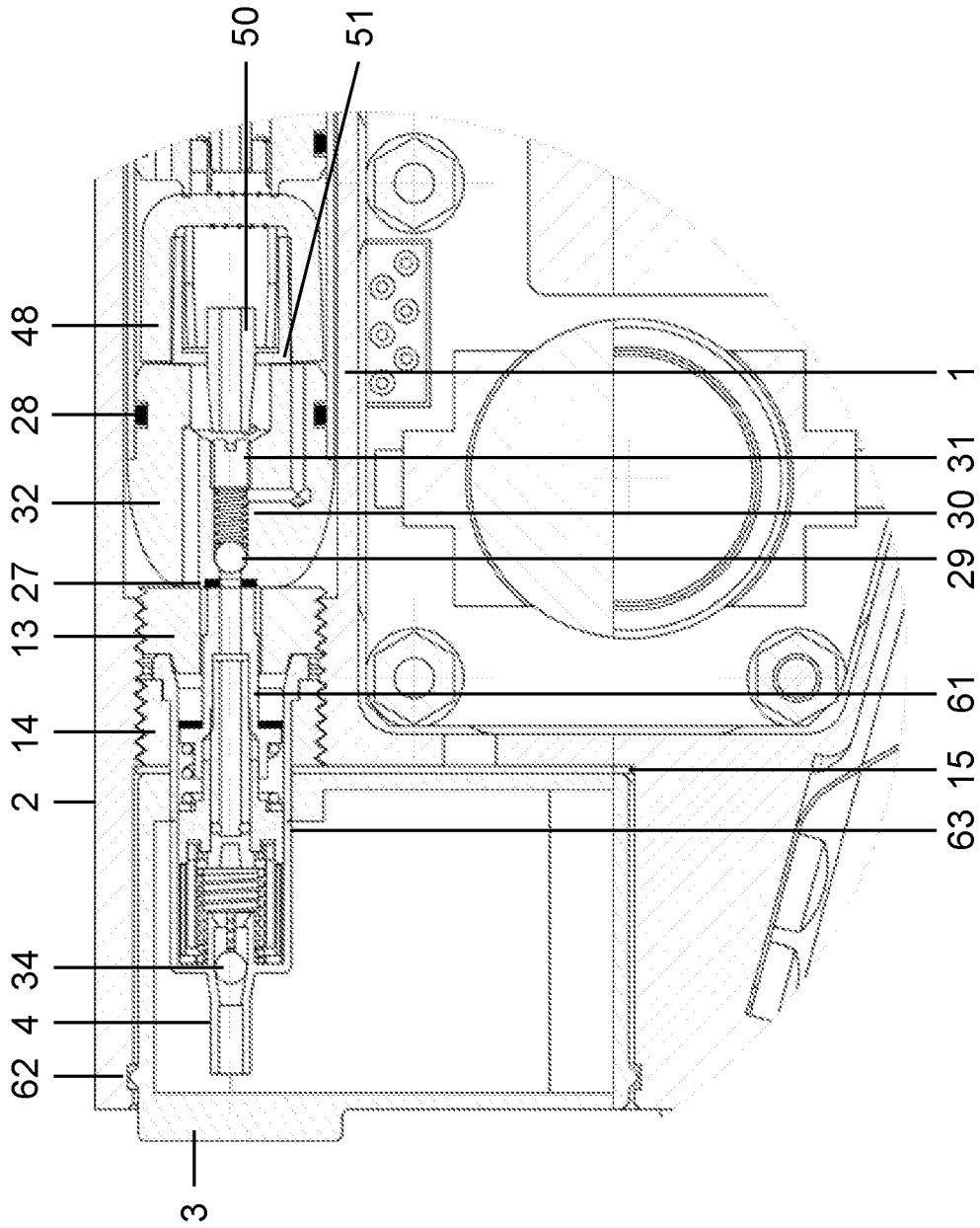

FIGURE 42

**PUMP WITH PISTON ASSY IN "START" POSITION
FLUID CHAMBER CHARGED**

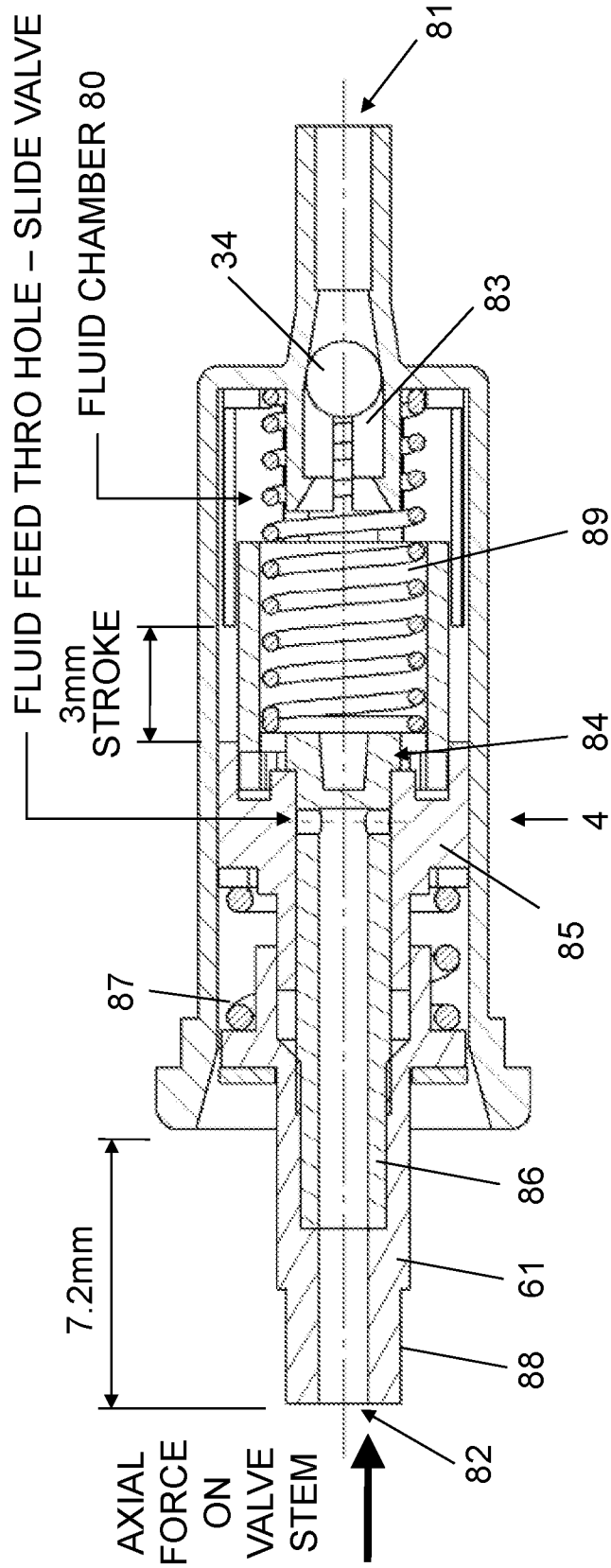

FIGURE 50

PUMP WITH FEED THRO HOLE IN "OPEN" POSITION

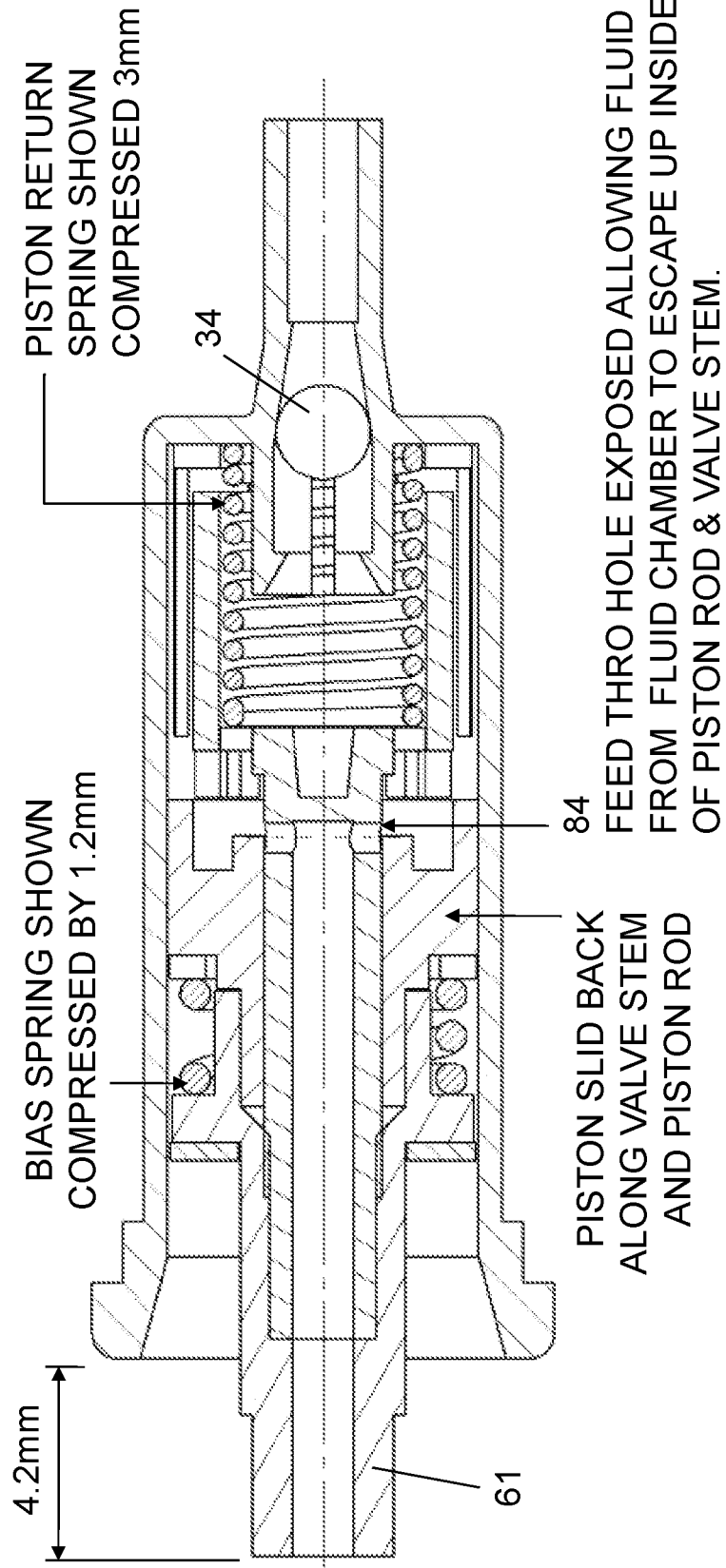
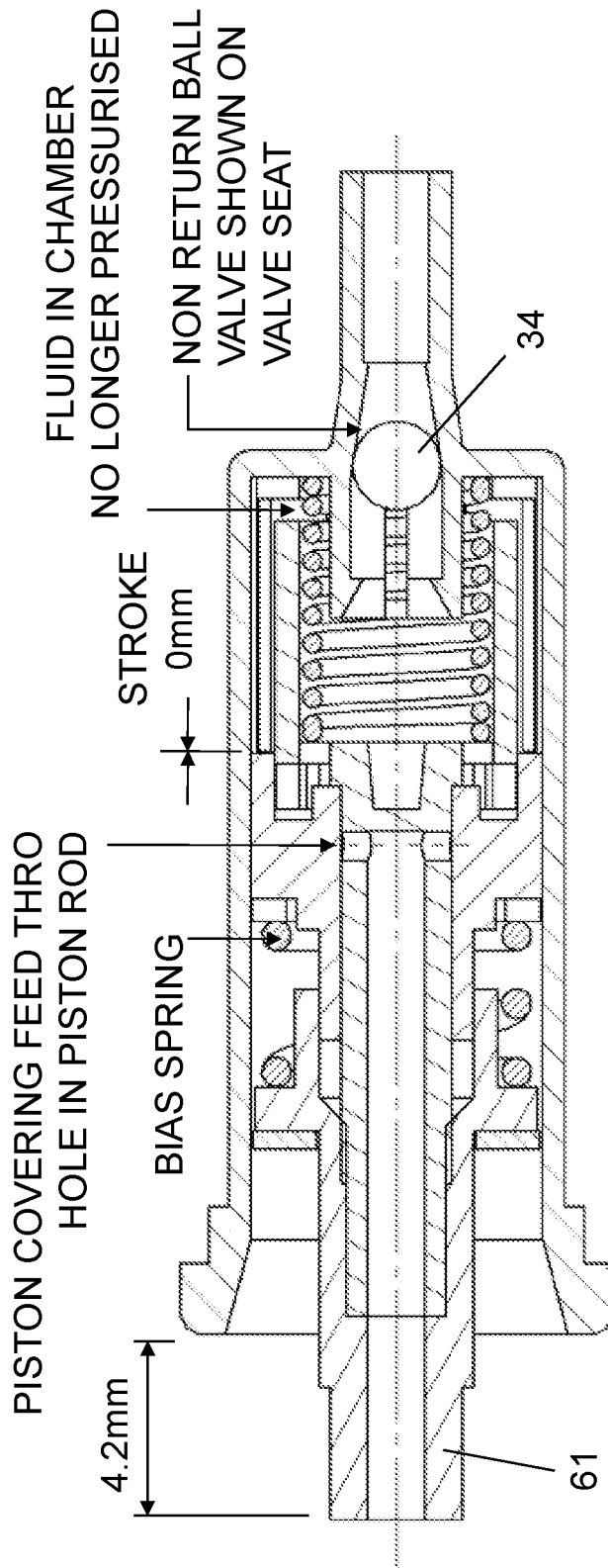

FIGURE 51

PUMP WITH PISTON ASSY IN "DOWN" POSITION



VIEW SHOWING PUMP WITH PISTON ASSEMBLY AT END OF 3mm STROKE - FLUID IN CHAMBER NO LONGER PRESSURISED, PISTON PUSHED BACK OVER FEED THRO HOLE BY BIAS SPRING.

FIGURE 52

**PUMP WITH PISTON ASSY IN "START" POSITION
FLUID CHAMBER CHARGING**

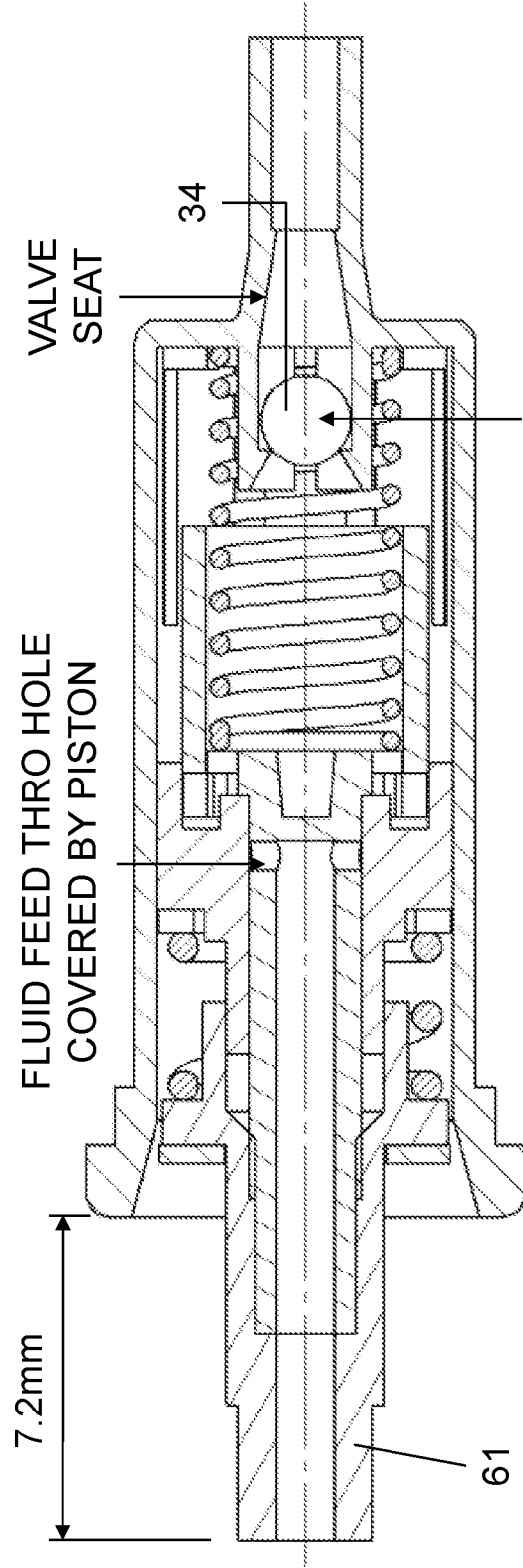

NON RETURN BALL VALVE SHOWN PULLED OFF IT'S SEAT
BY VACUUM INFRONT OF PISTON HEAD MOVING BACK.
FLUID FROM RESERVOIR FILLS CHARGING CHAMBER.

FIGURE 53

INTEGRATED PUMP / RESERVOIR / OVERFLOW VALVE IN "START" POSITION

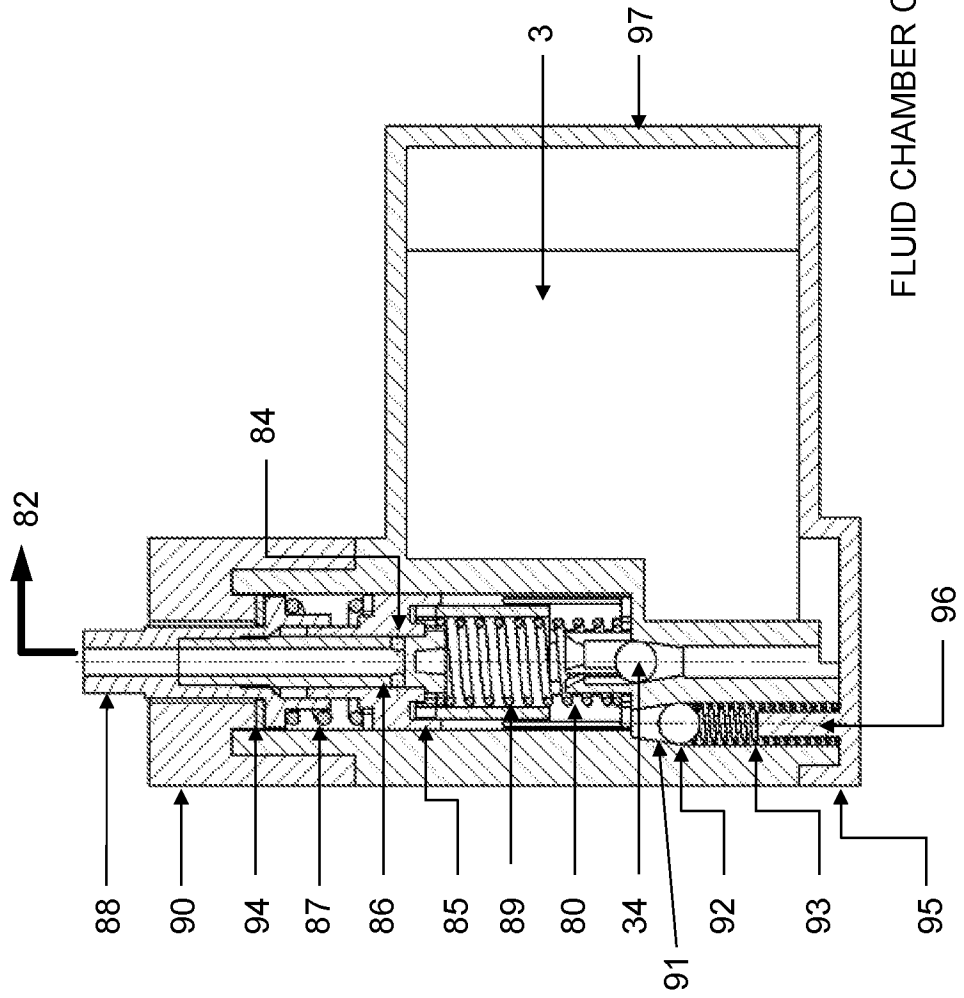

FIGURE 55

INTEGRATED PUMP / RESERVOIR / OVERFLOW VALVE IN "OPEN" POSITION

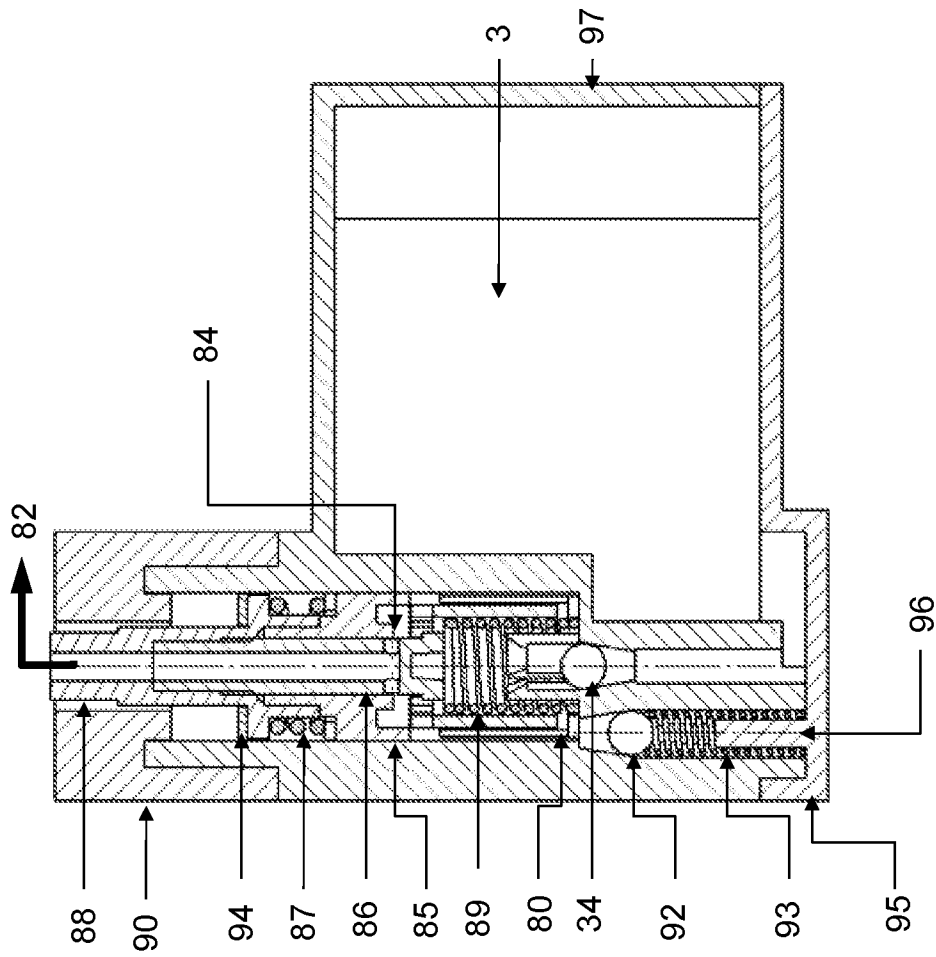

FIGURE 56

INTEGRATED PUMP / RESERVOIR / OVERFLOW VALVE IN "DOWN" POSITION

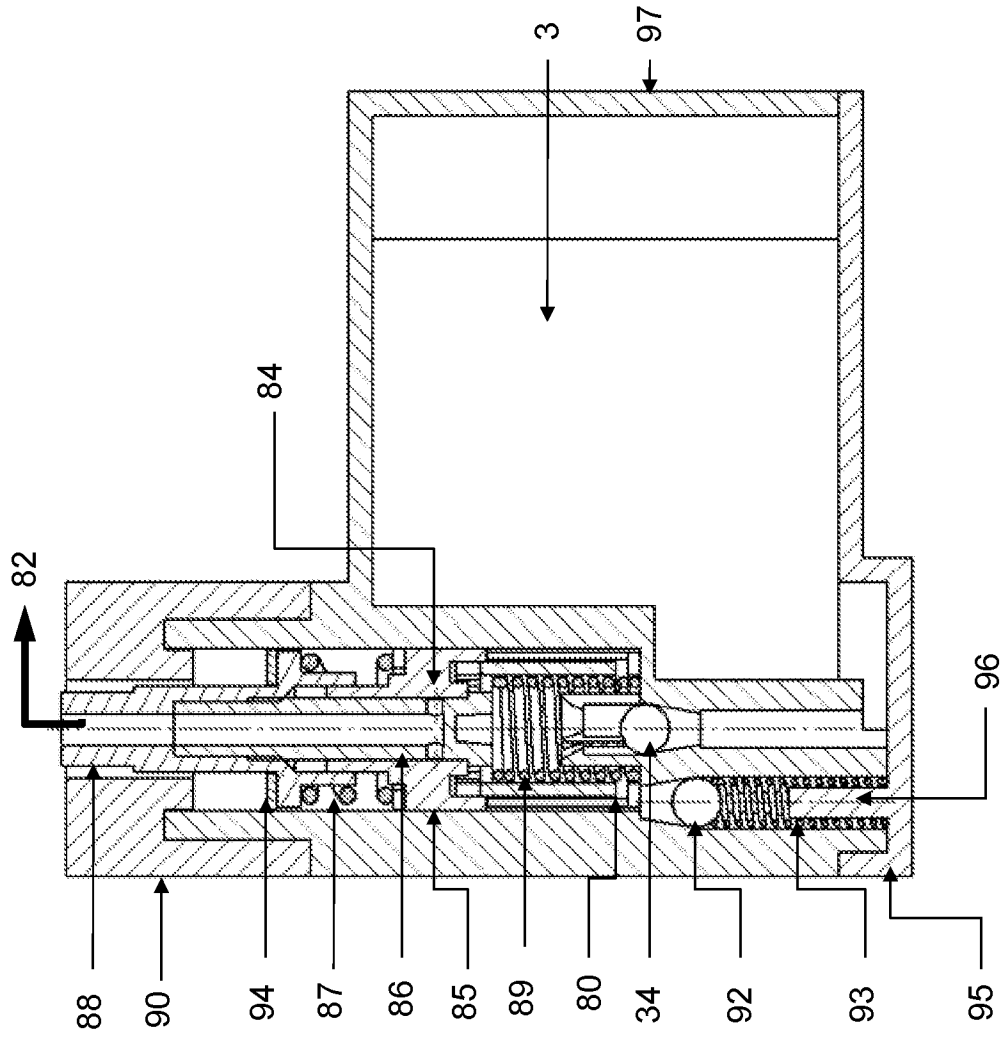

FIGURE 57

INTEGRATED PUMP / RESERVOIR / OVERFLOW VALVE IN "BYPASS" CONDITION
THIS POSITION IS CONDITIONAL ON HYDRAULIC DESIGN LIMIT BEING EXCEEDED

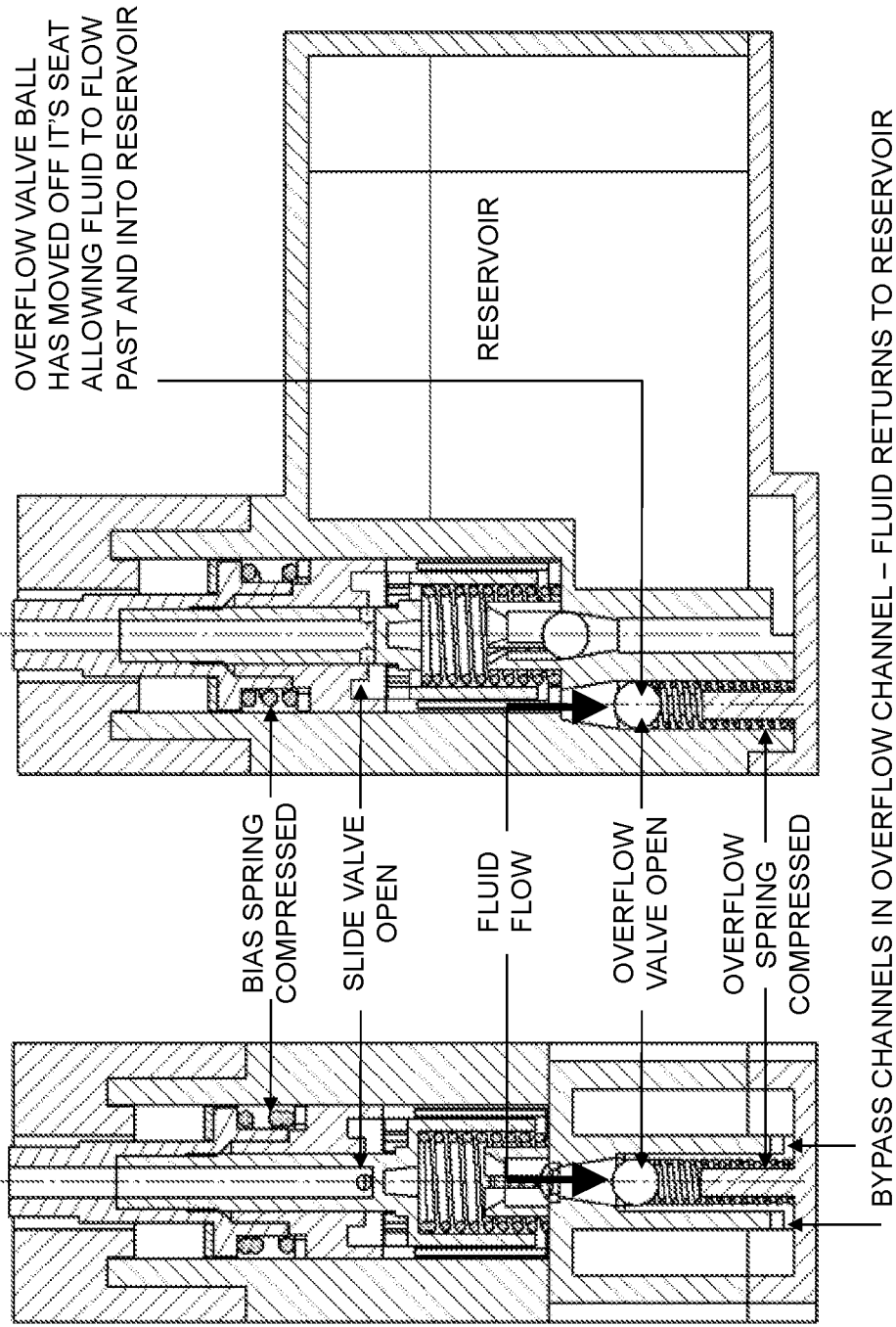

FIGURE 58

INTEGRATED PUMP / RESERVOIR / OVERFLOW VALVE IN "RETURN" POSITION

AXIAL FORCE REMOVED FROM VALVE STEM
PUMP PISTON ASSEMBLY RETURNS TO START
POSITION PUSHED BY RETURN SPRING.

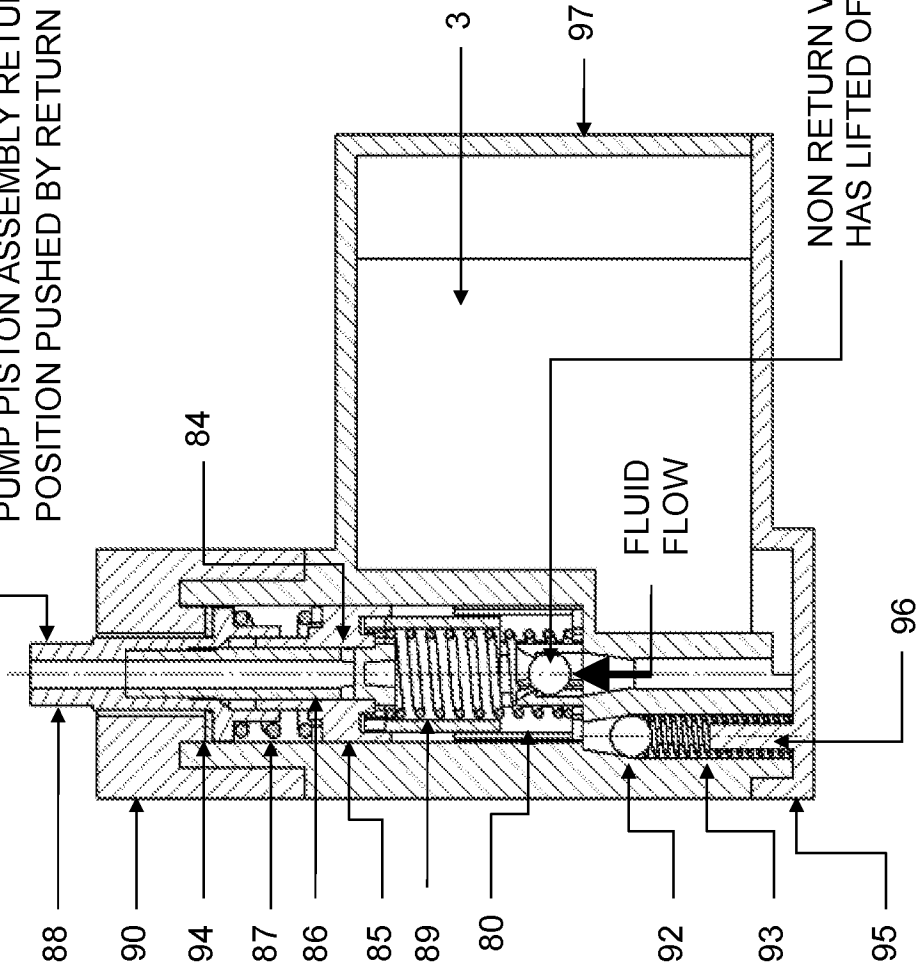

FIGURE 59

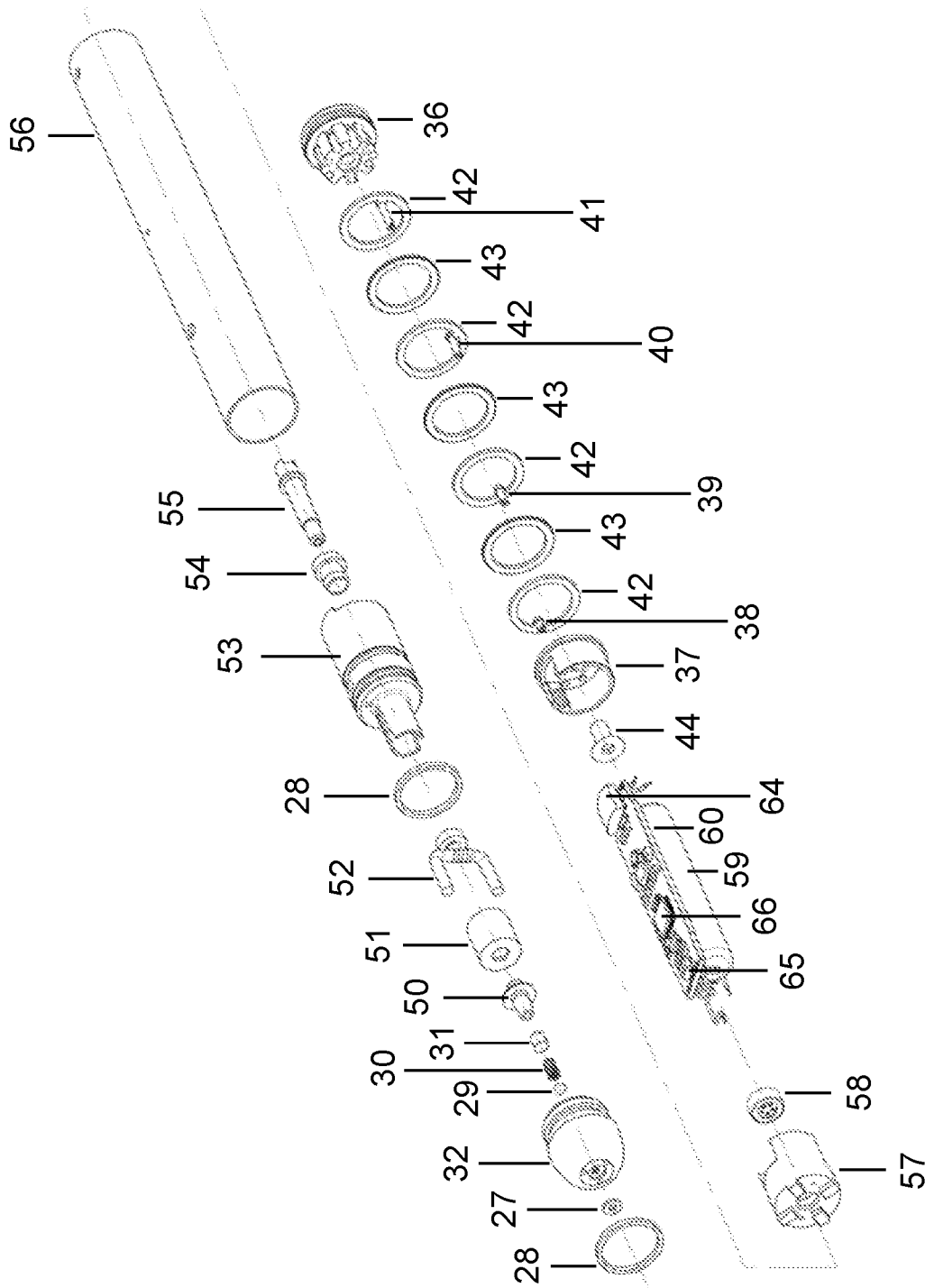

FIGURE 60

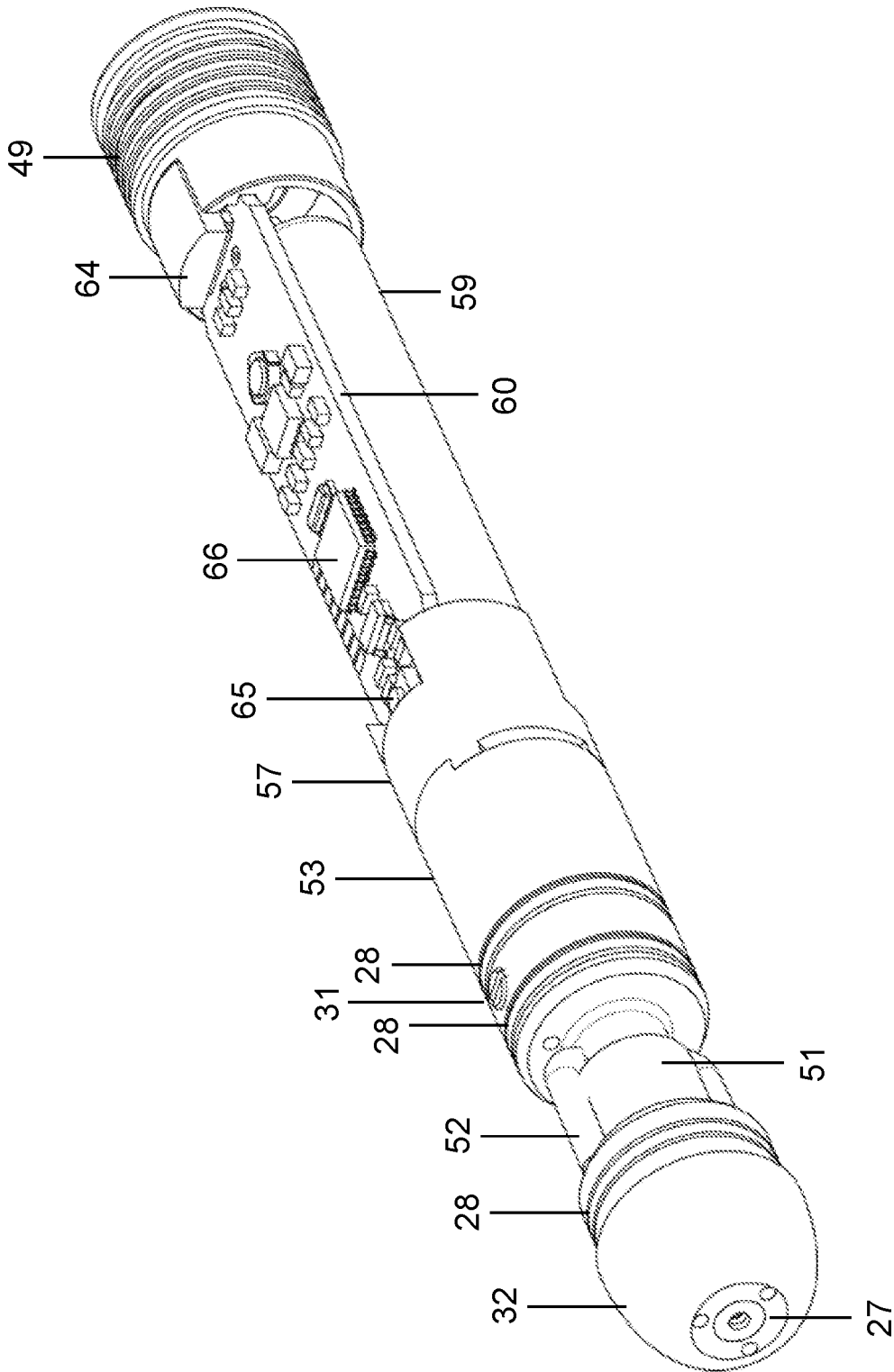

FIGURE 61

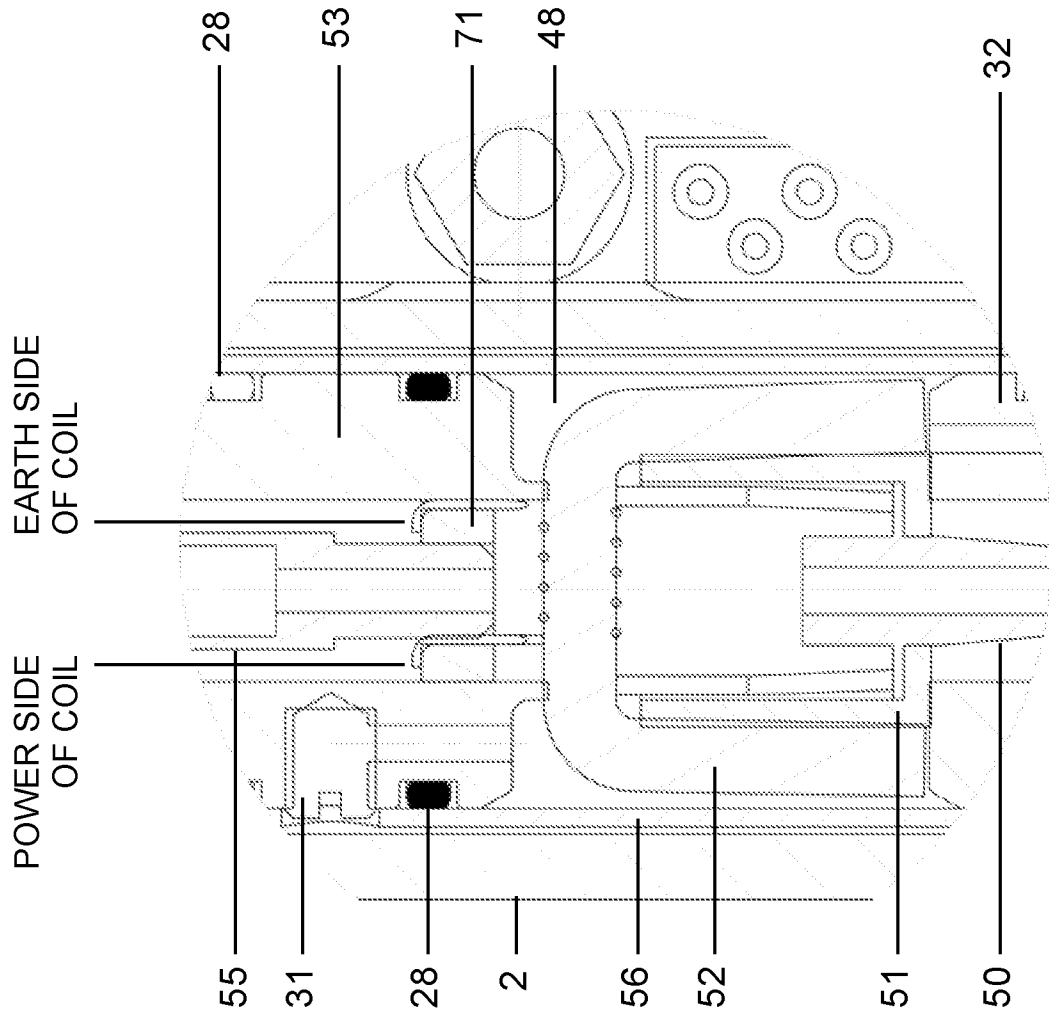

FIGURE 62

50/77

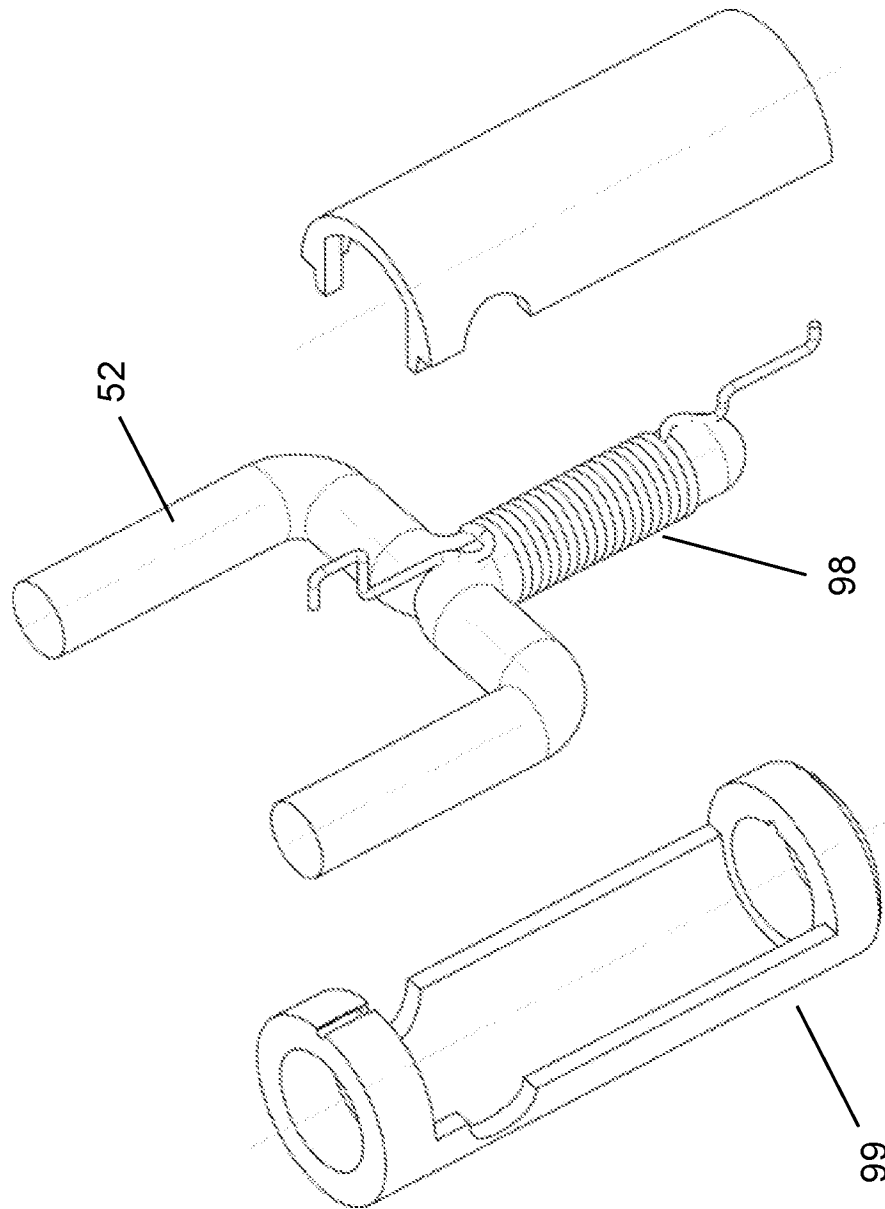

FIGURE 63

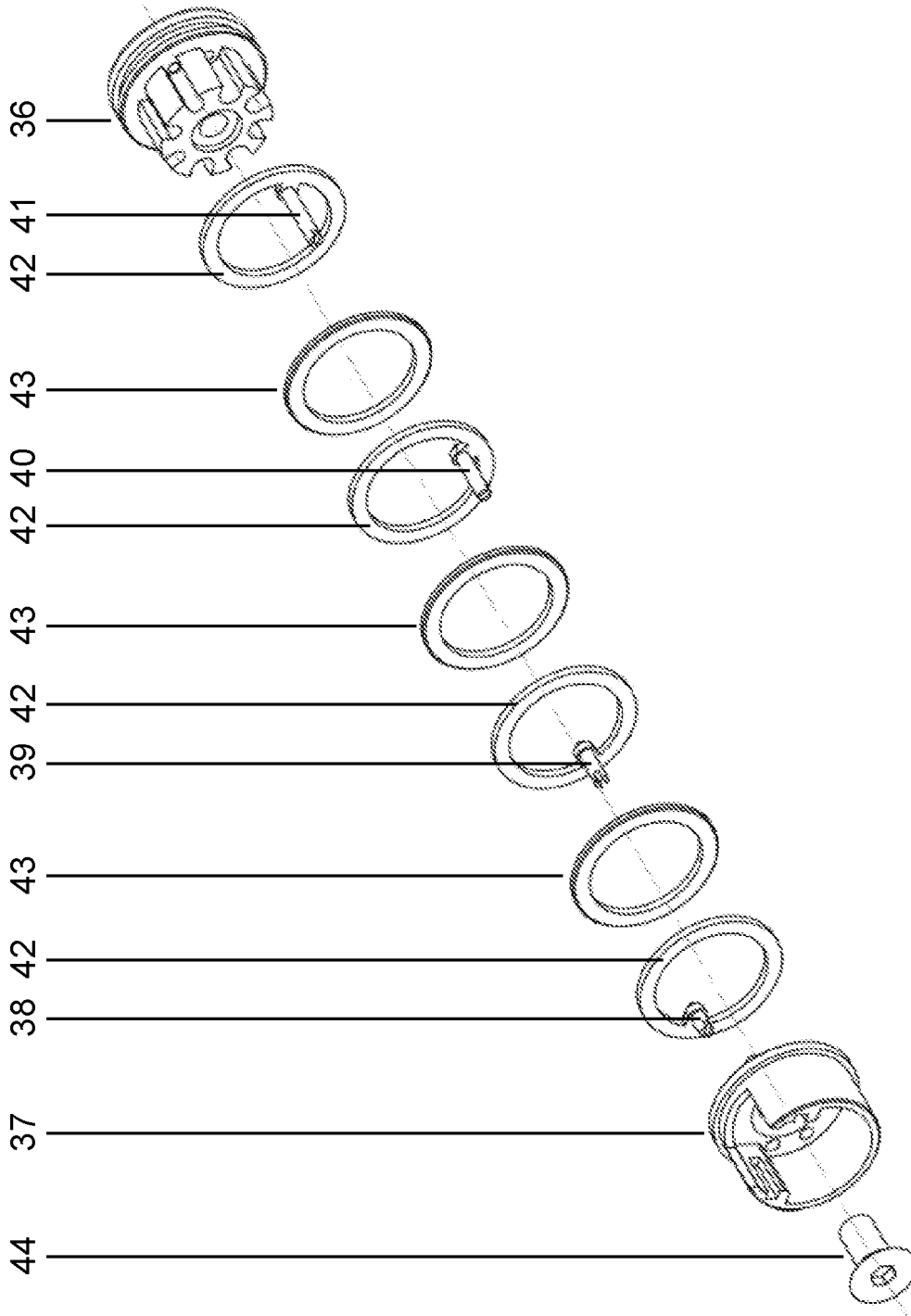

FIGURE 65

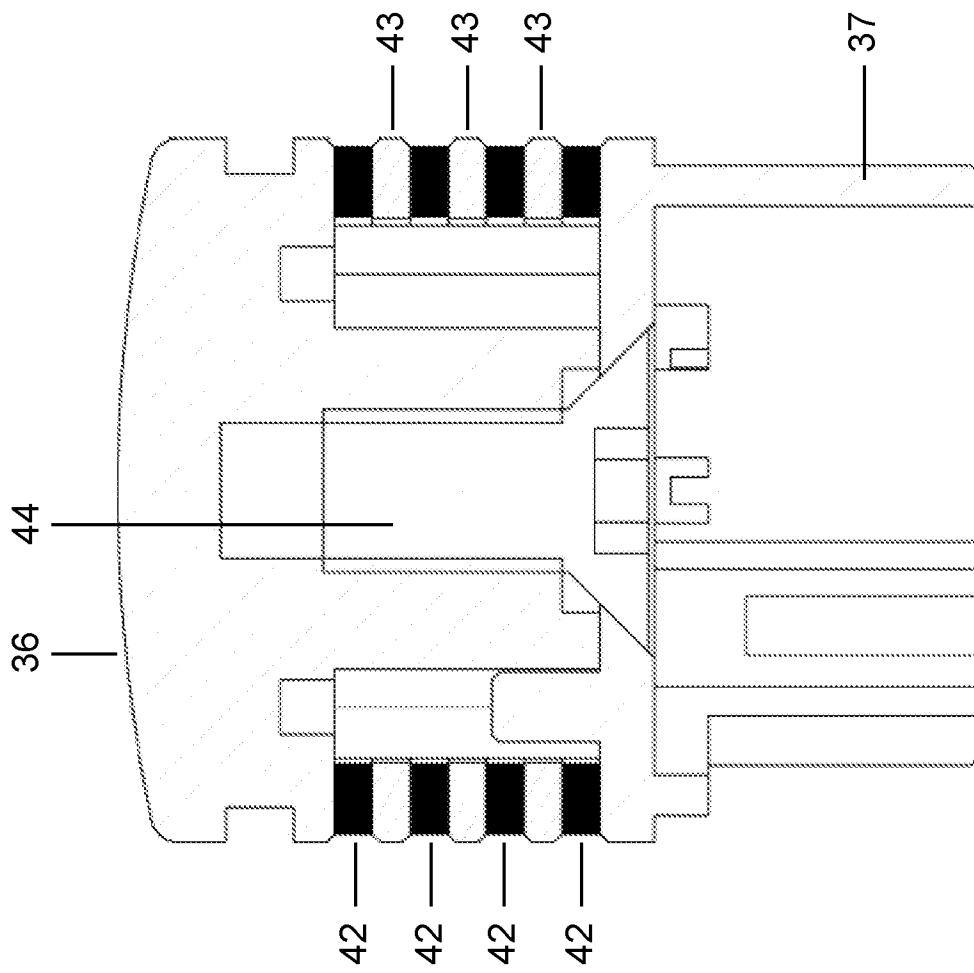
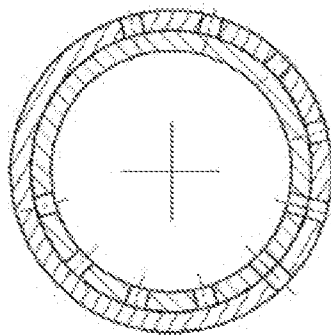
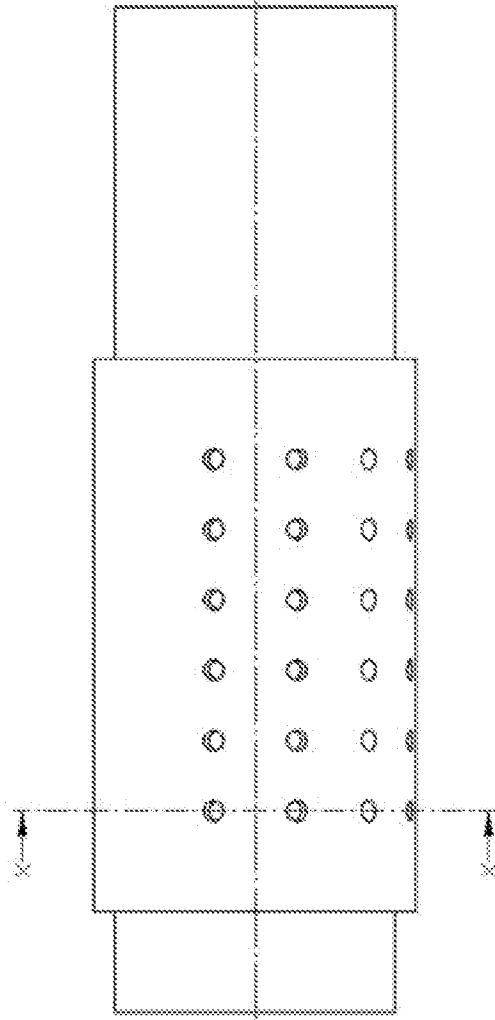

FIGURE 66

VAPING VARIABLE AIR INTAKE
SQUARE INNER & OUTER MATRIX
AIR PATH WITH 2 ROWS OF HOLES LINED UP



SECTION N-N

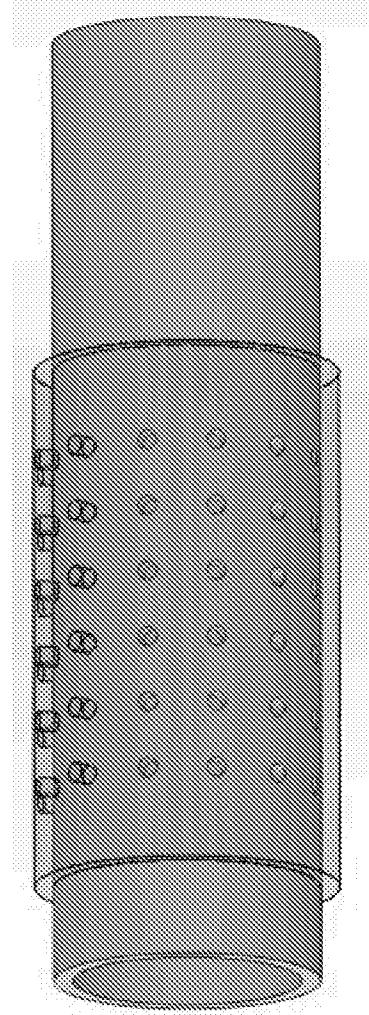

FIGURE 67

VAPING VARIABLE AIR INTAKE
SQUARE INNER & OUTER MATRIX
AIR PATH WITH 5 ROWS OF HOLES LINED UP

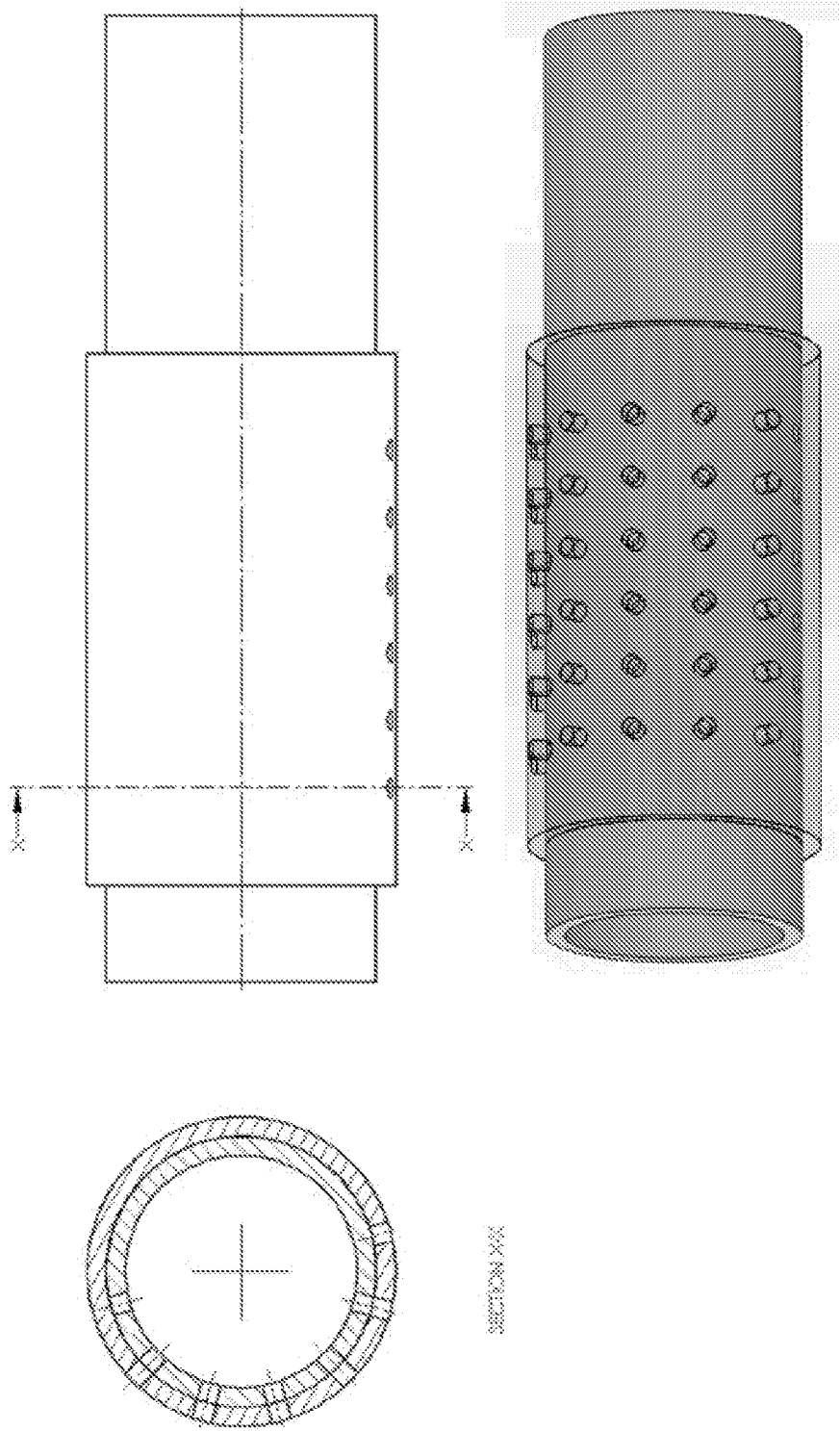

FIGURE 68

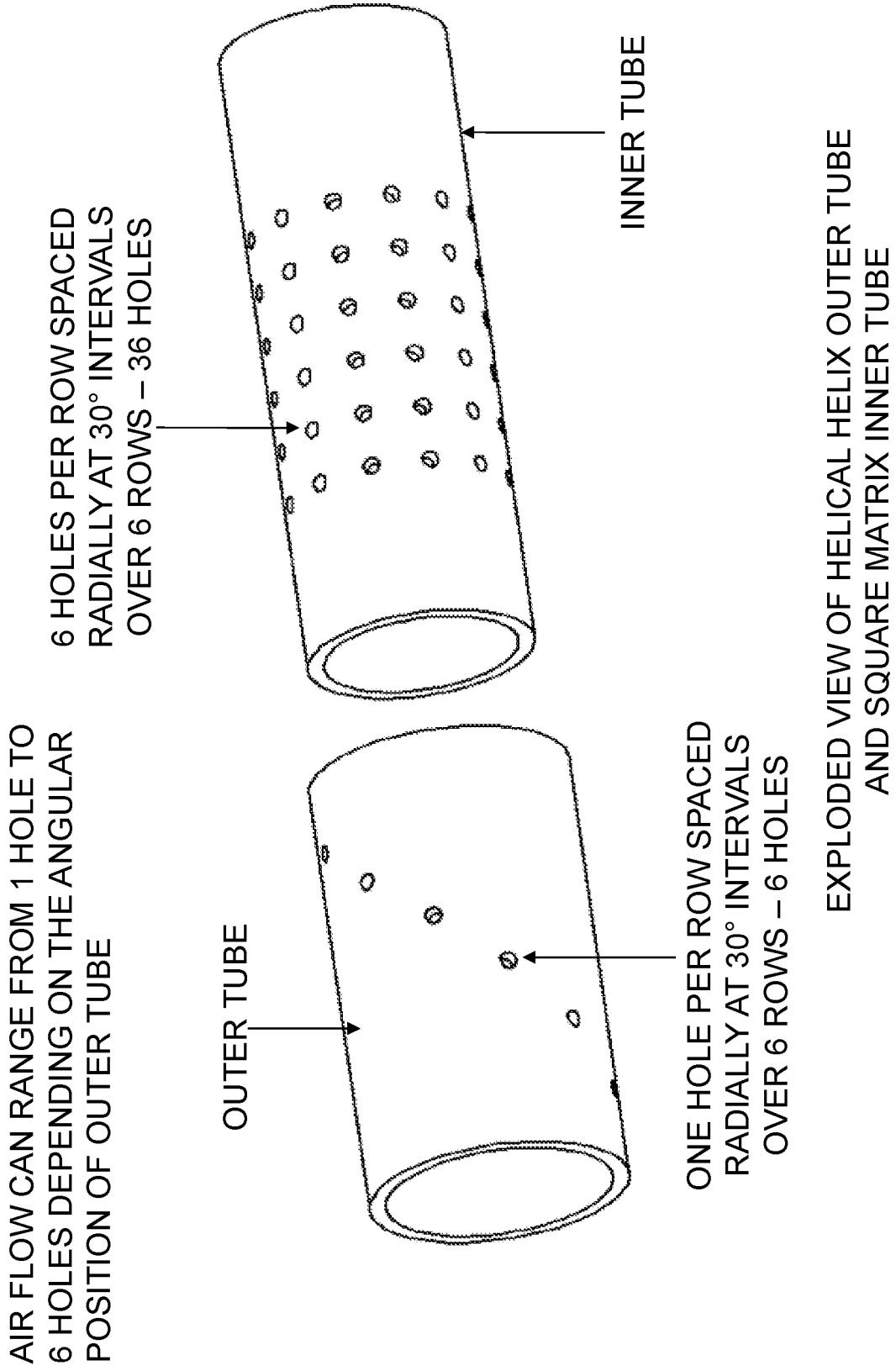

FIGURE 69

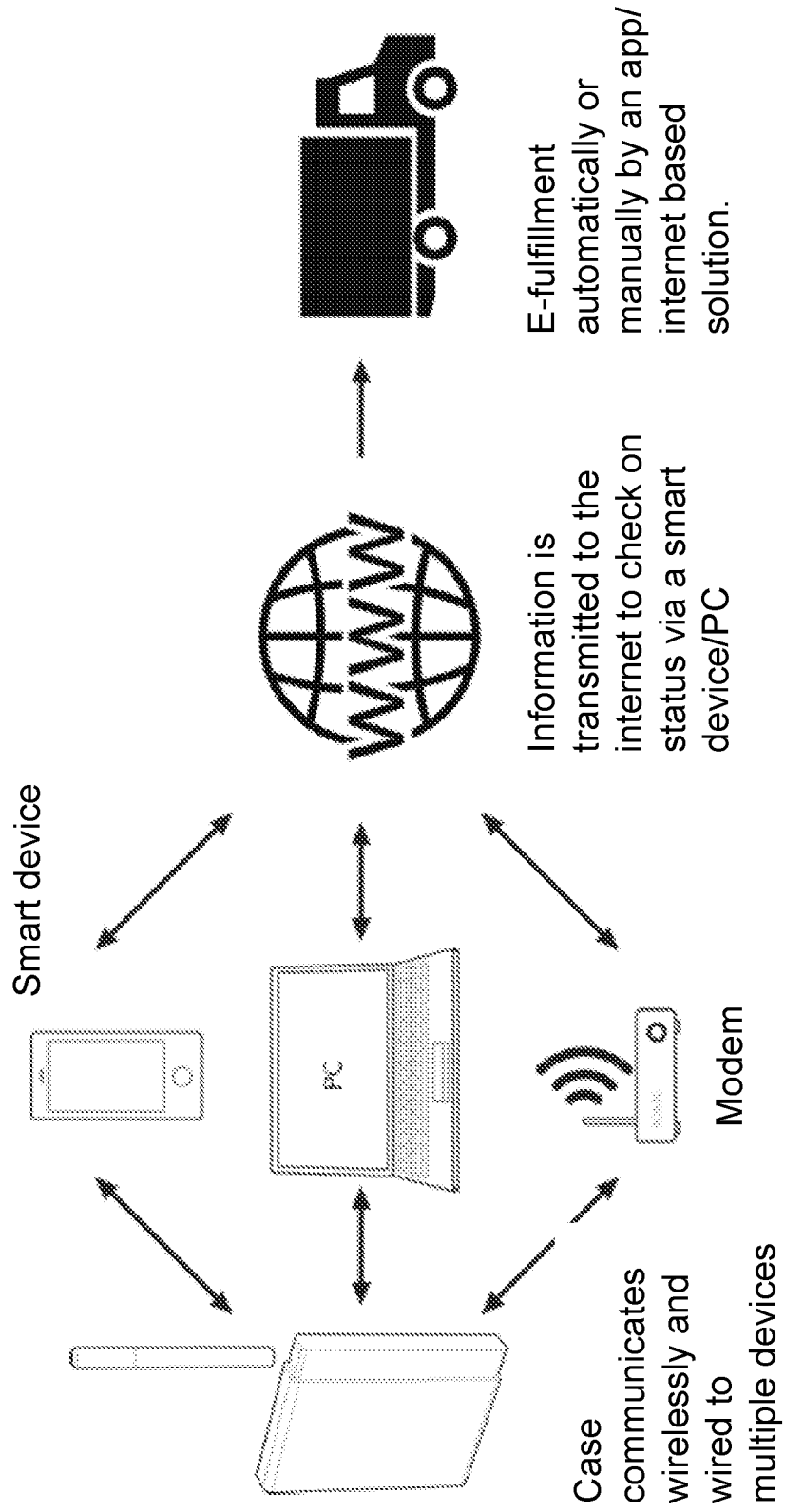
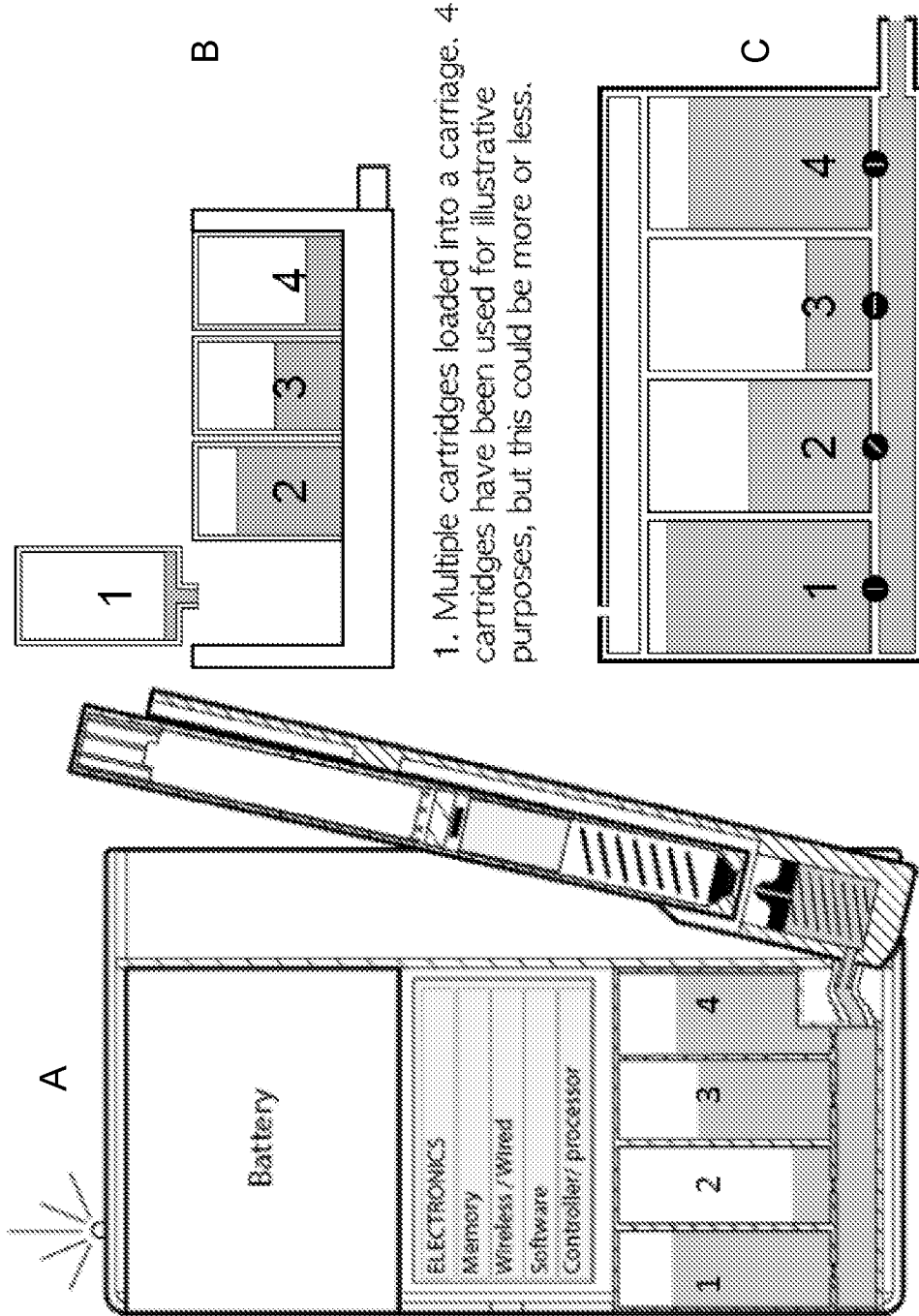

FIGURE 70



1. Multiple cartridges loaded into a carriage. 4 cartridges have been used for illustrative purposes, but this could be more or less.

FIGURE 71

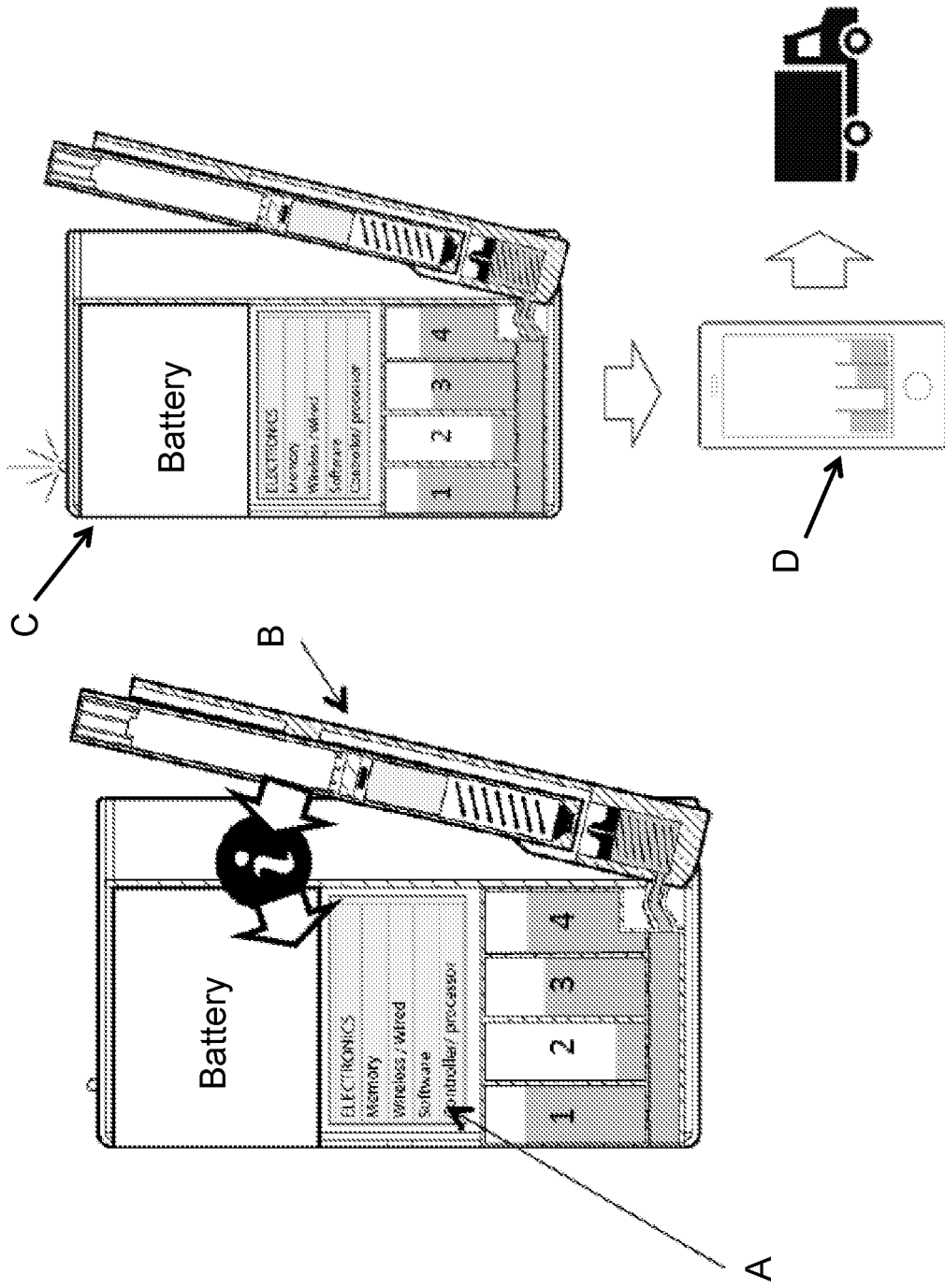

FIGURE 72

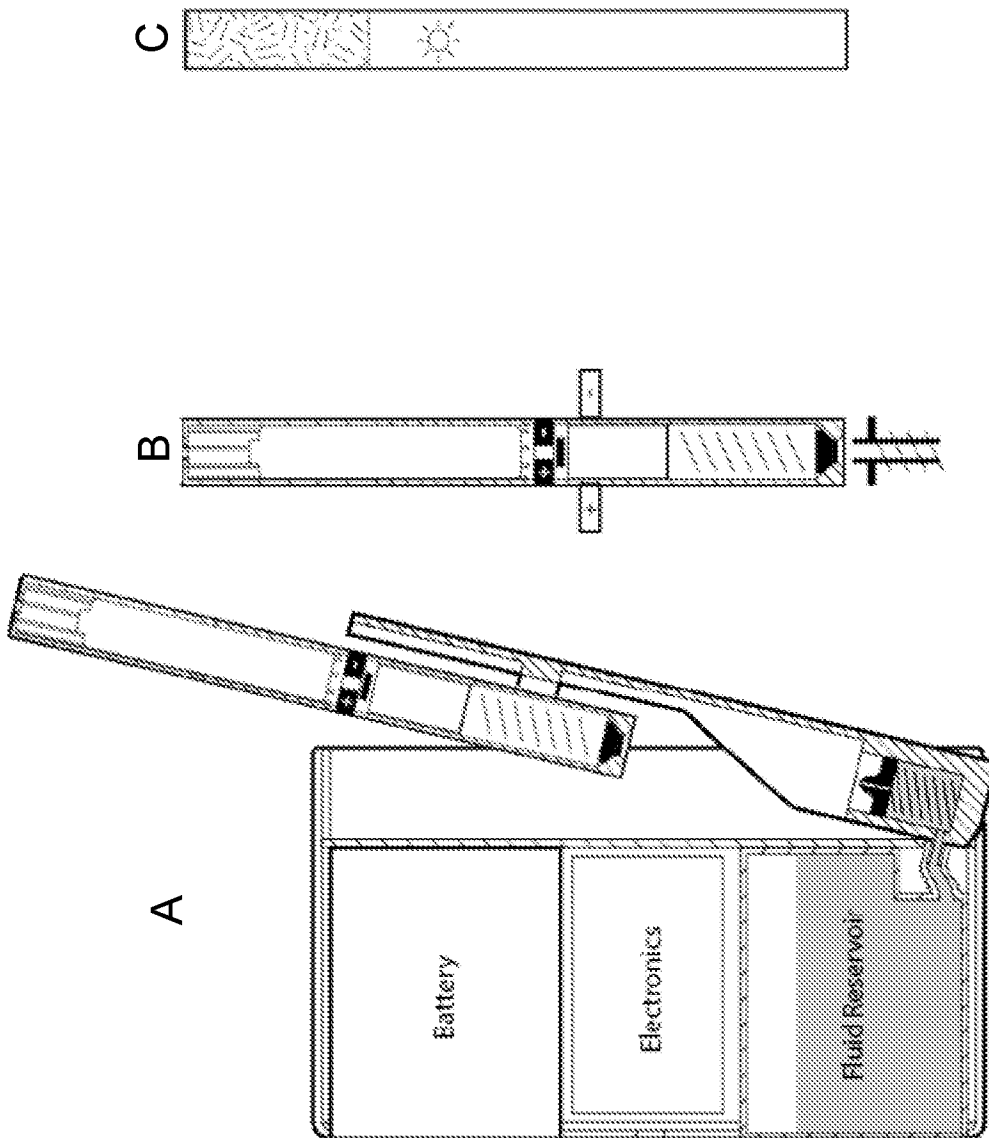

FIGURE 73

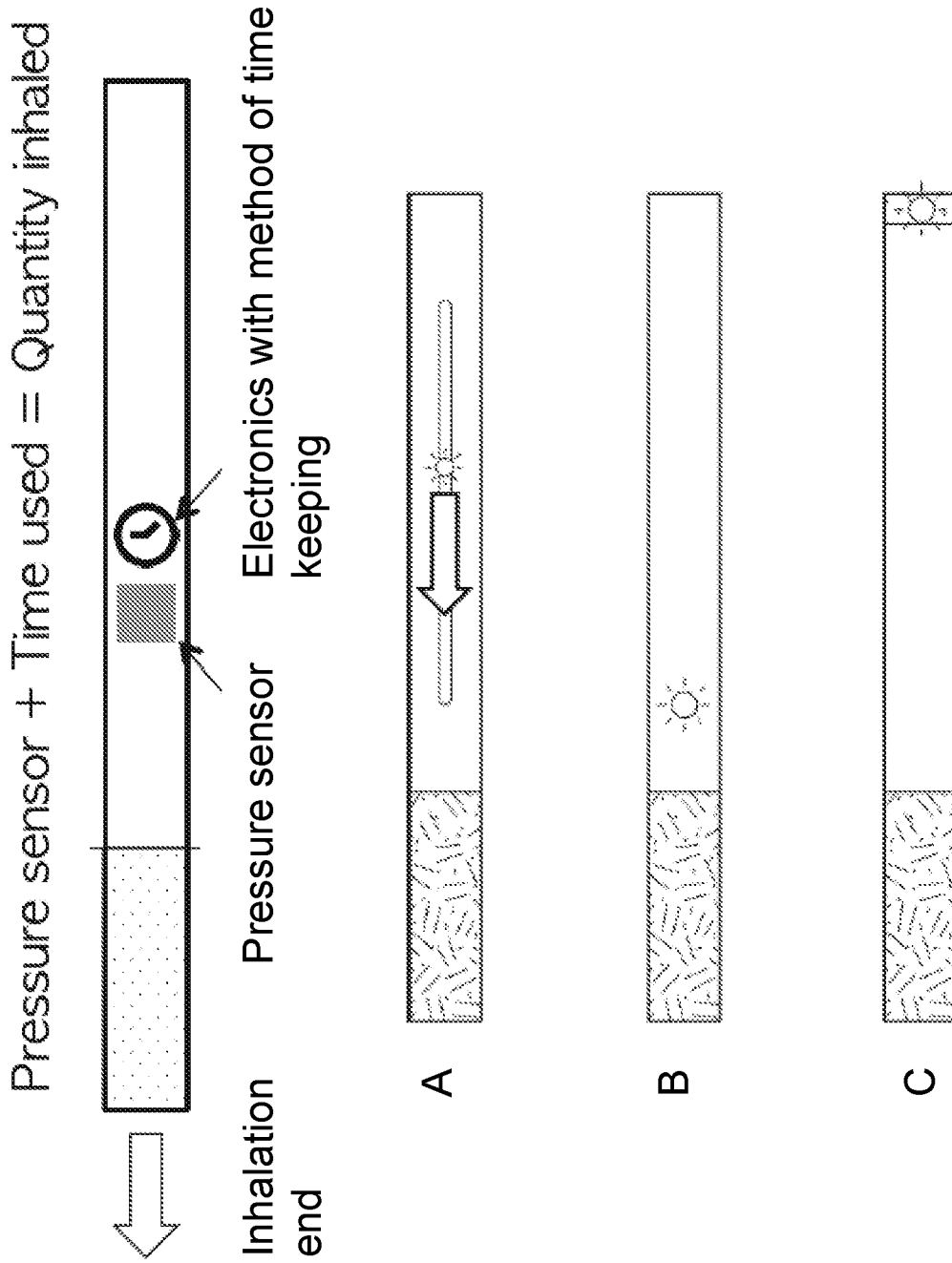

FIGURE 74

61/77

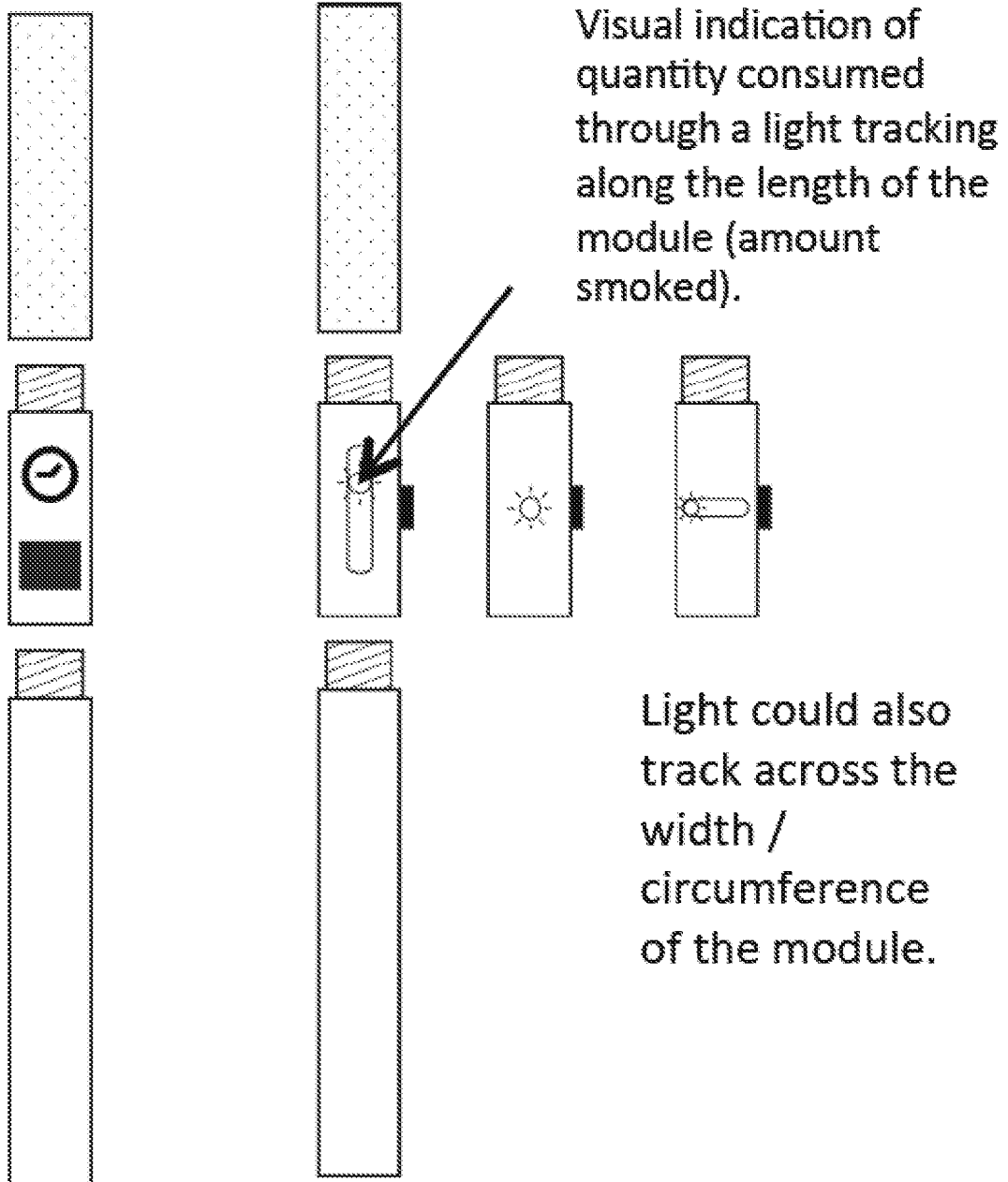

FIGURE 75

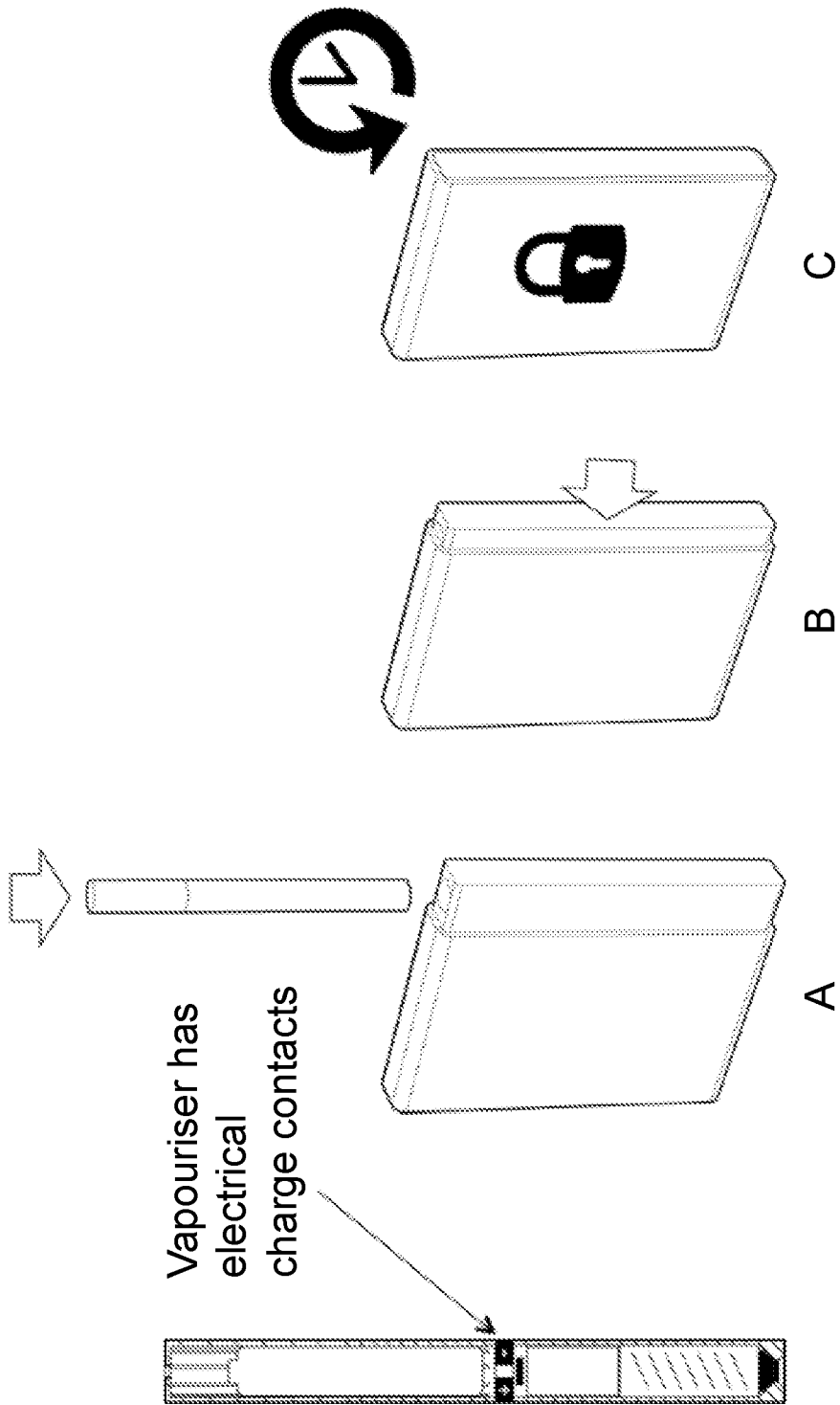

FIGURE 76

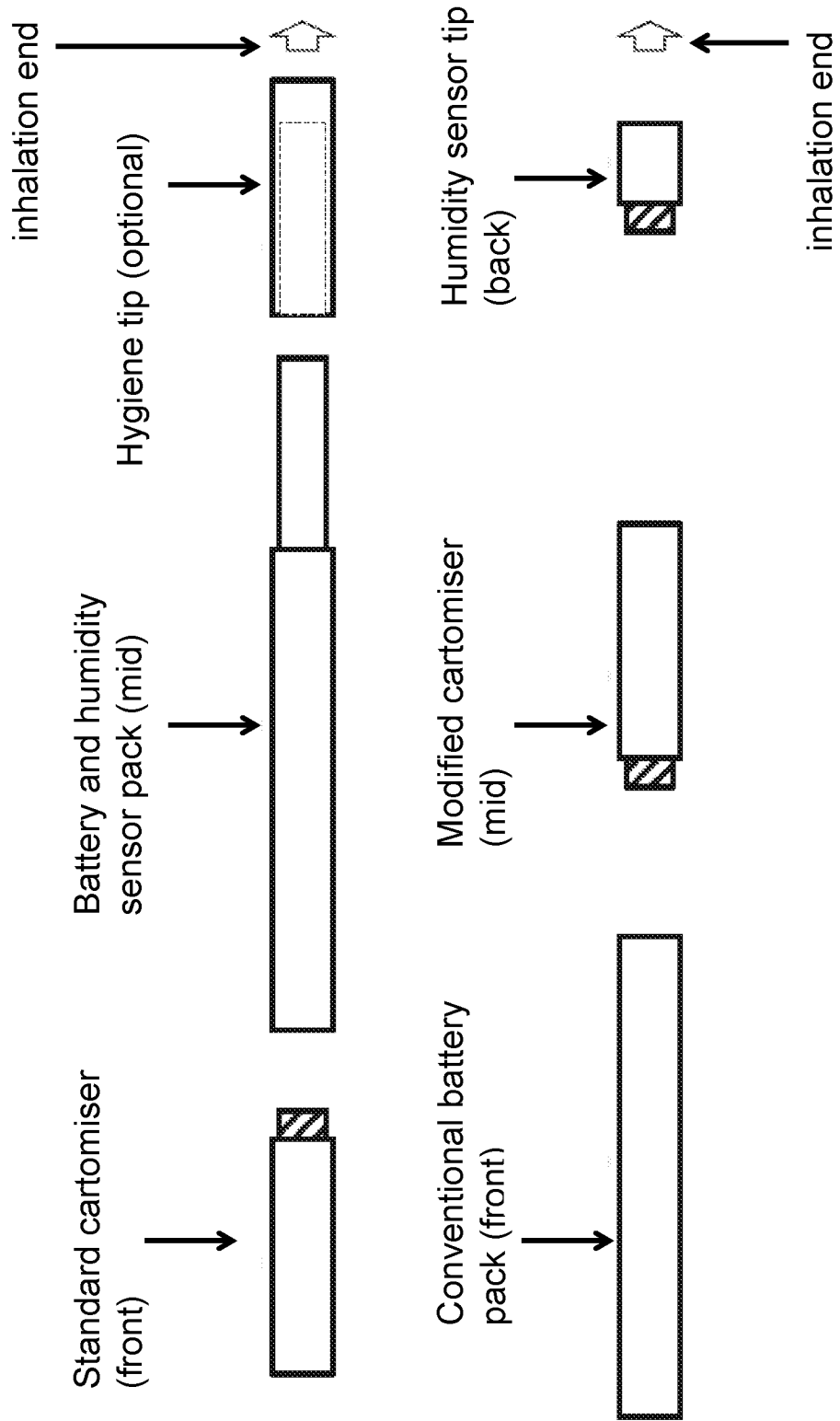

FIGURE 77

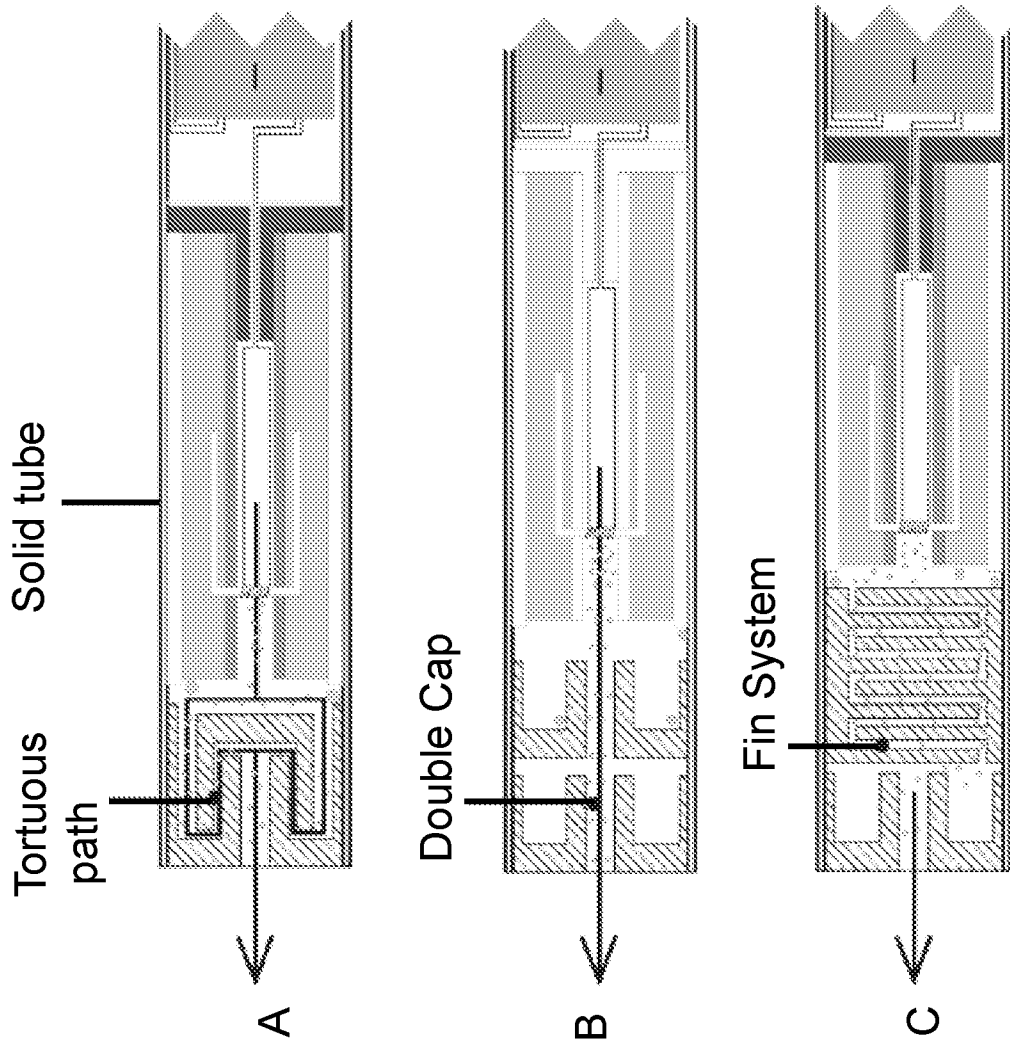

FIGURE 80

65/77

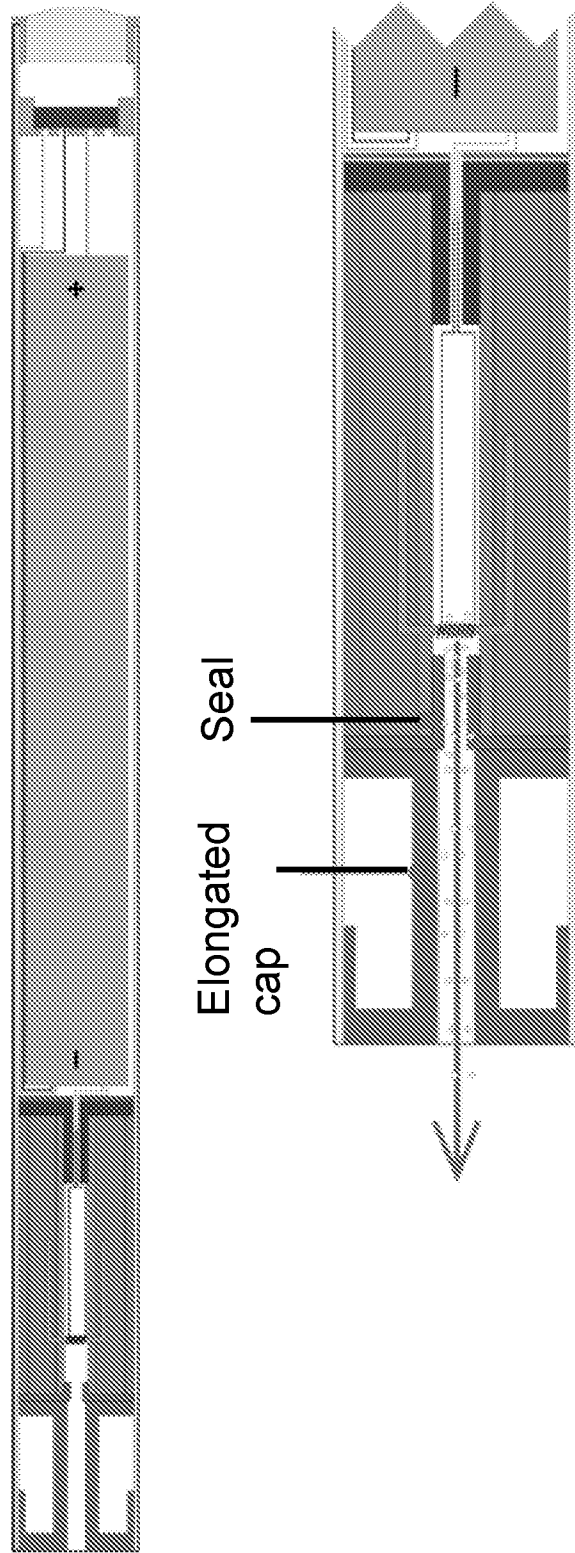

FIGURE 81

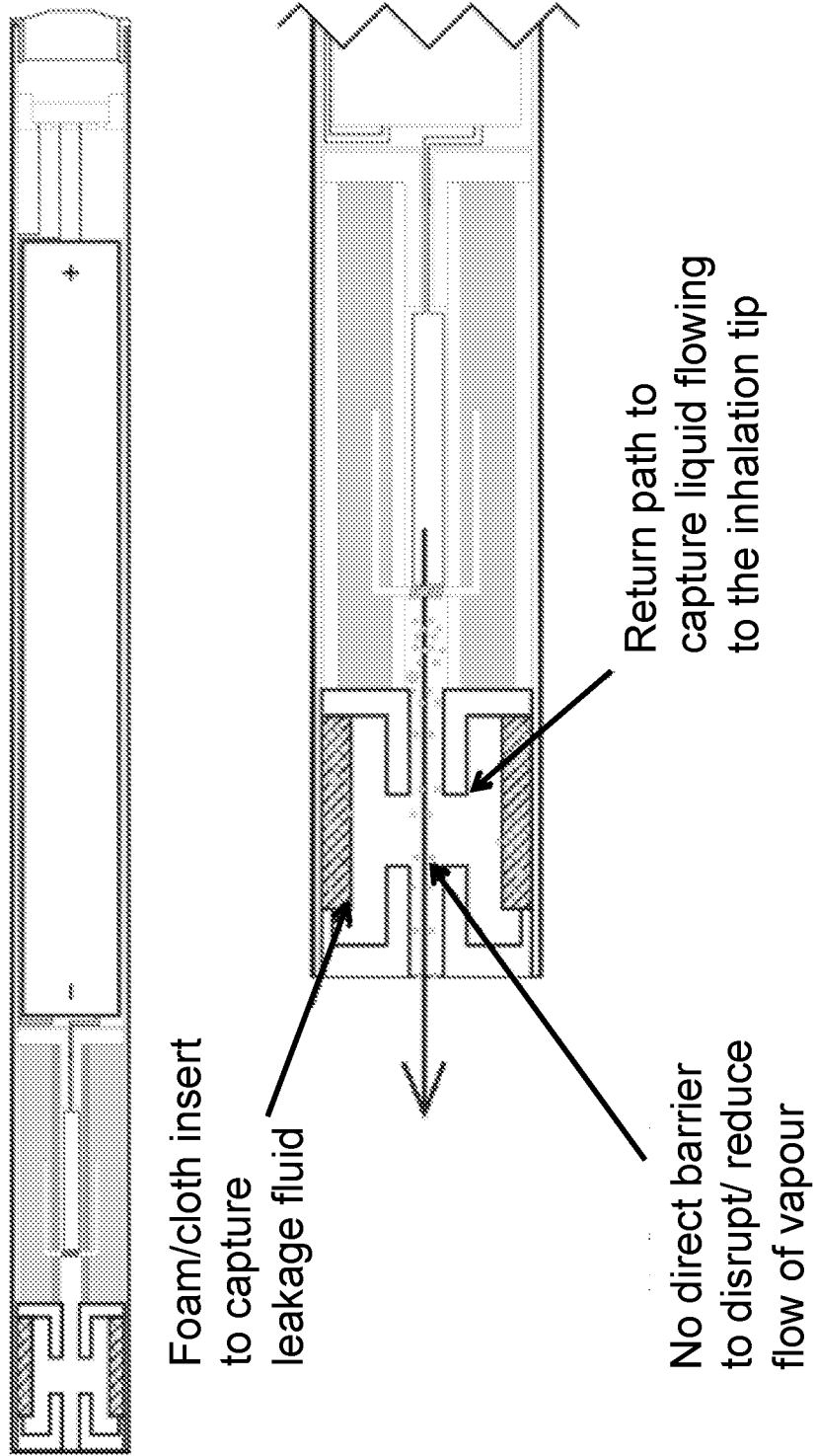
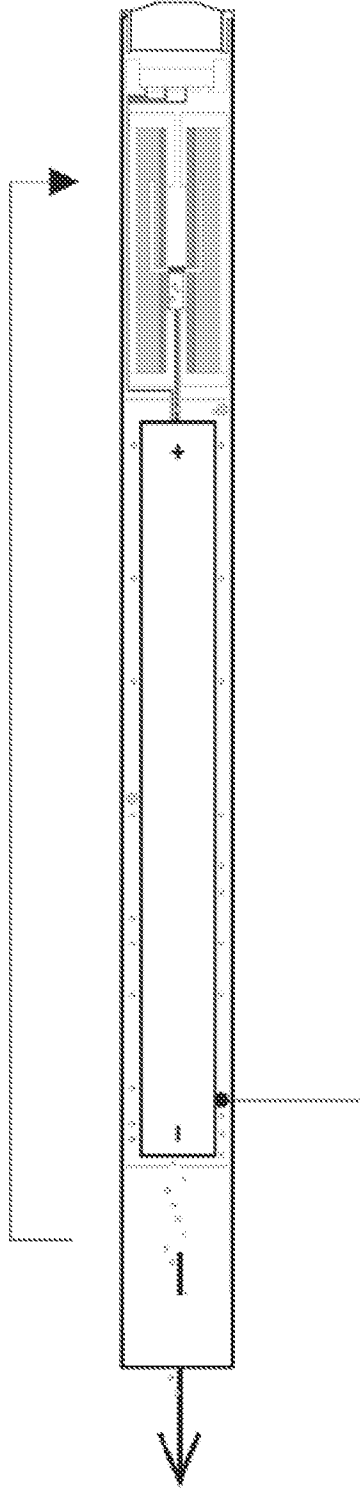

FIGURE 82

67/77

Proposed new configuration

Moved liquid chamber and heating



Tortuous path for vapour and liquid

FIGURE 83

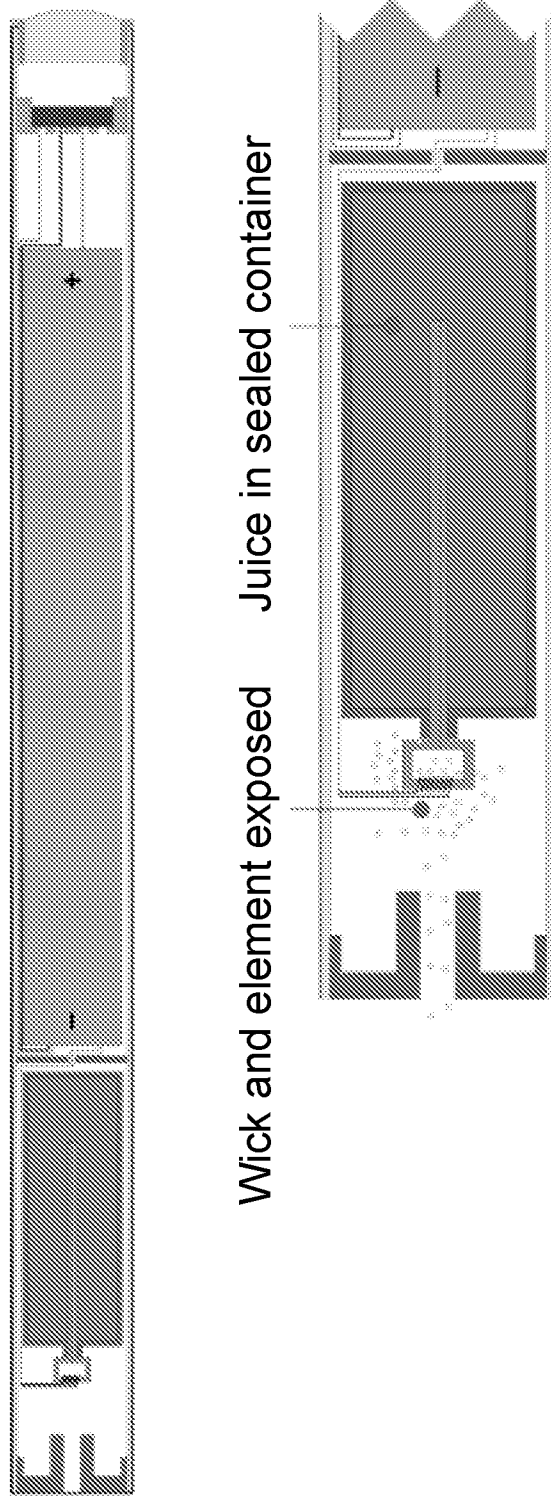

FIGURE 84

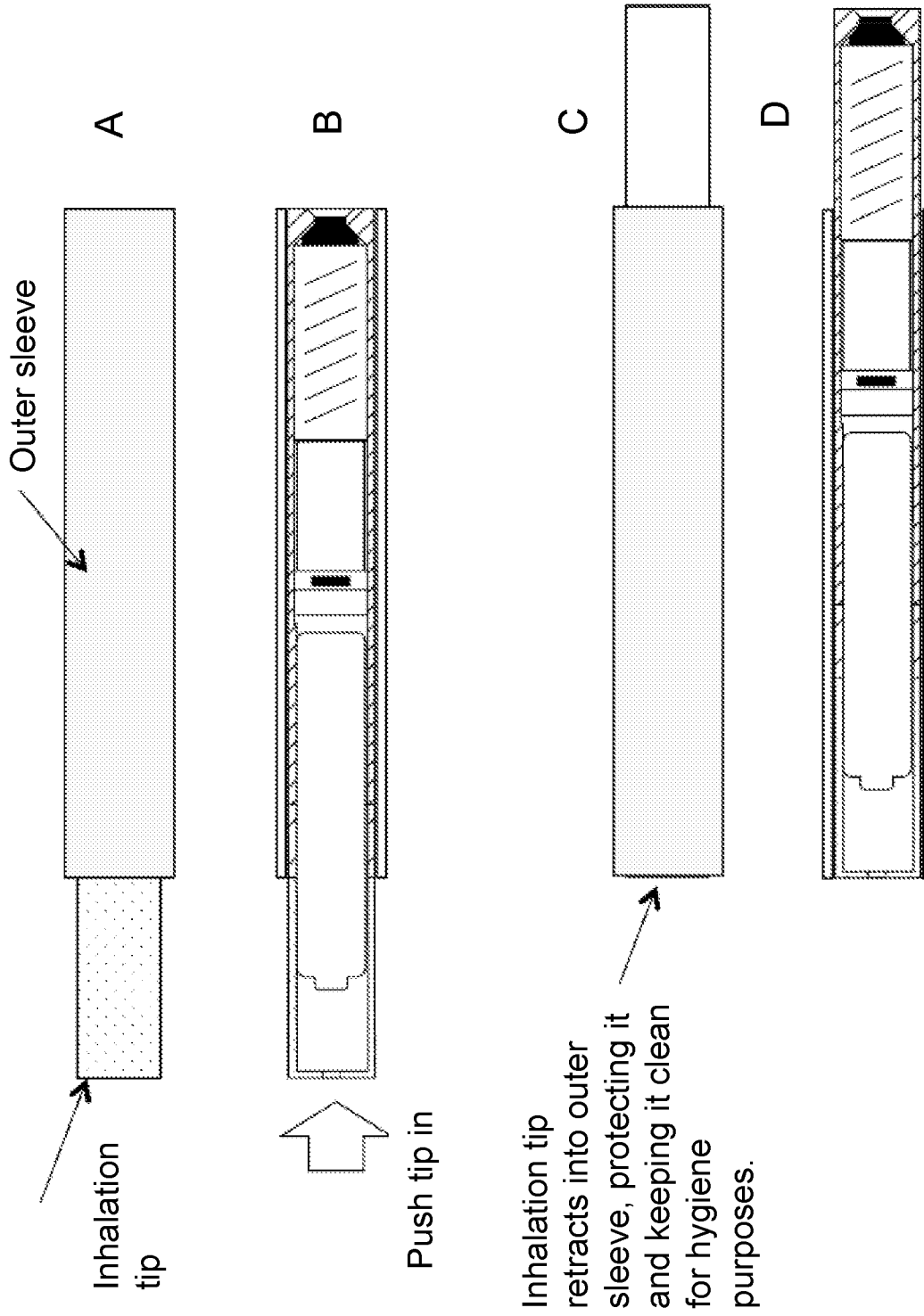

FIGURE 85

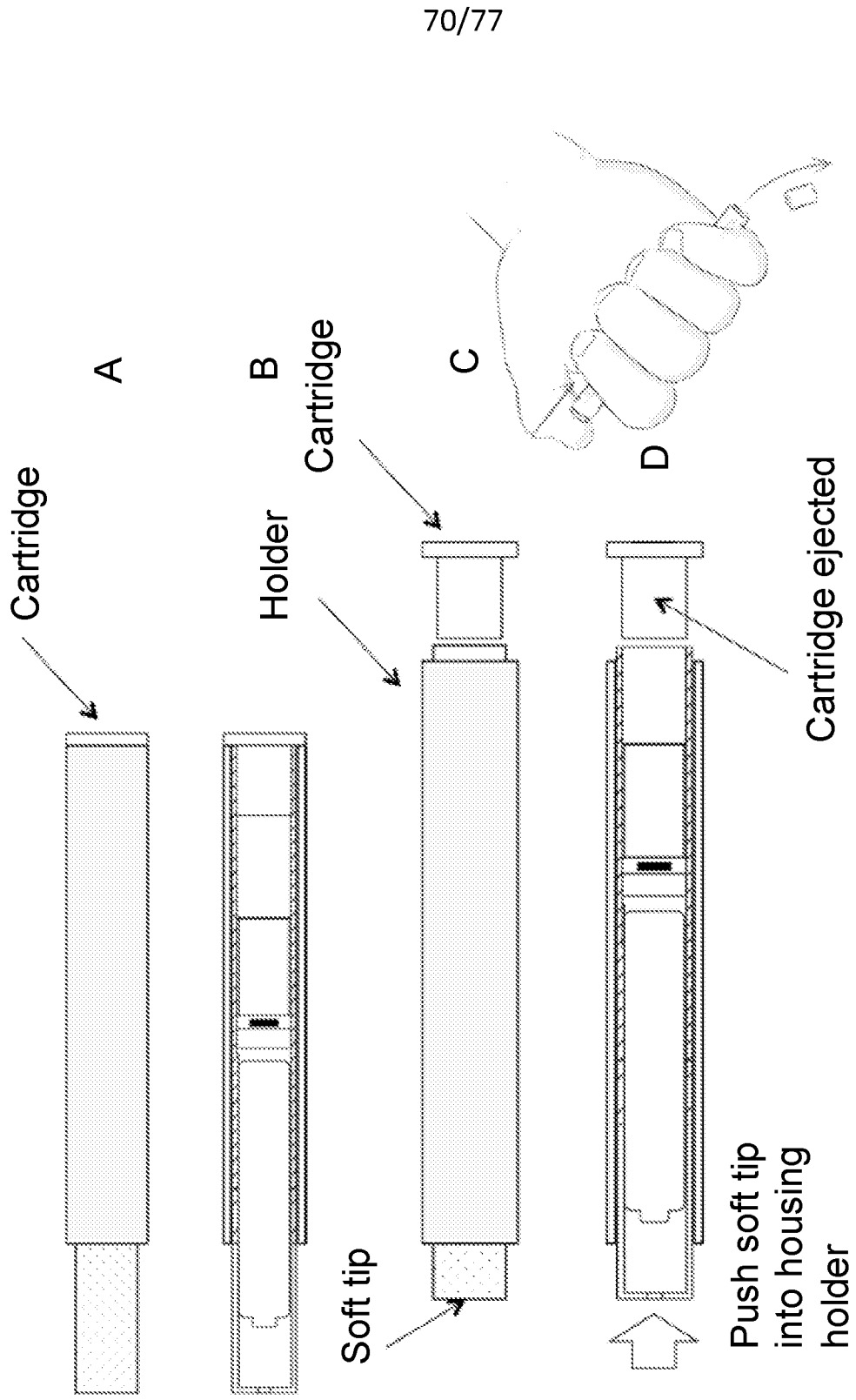
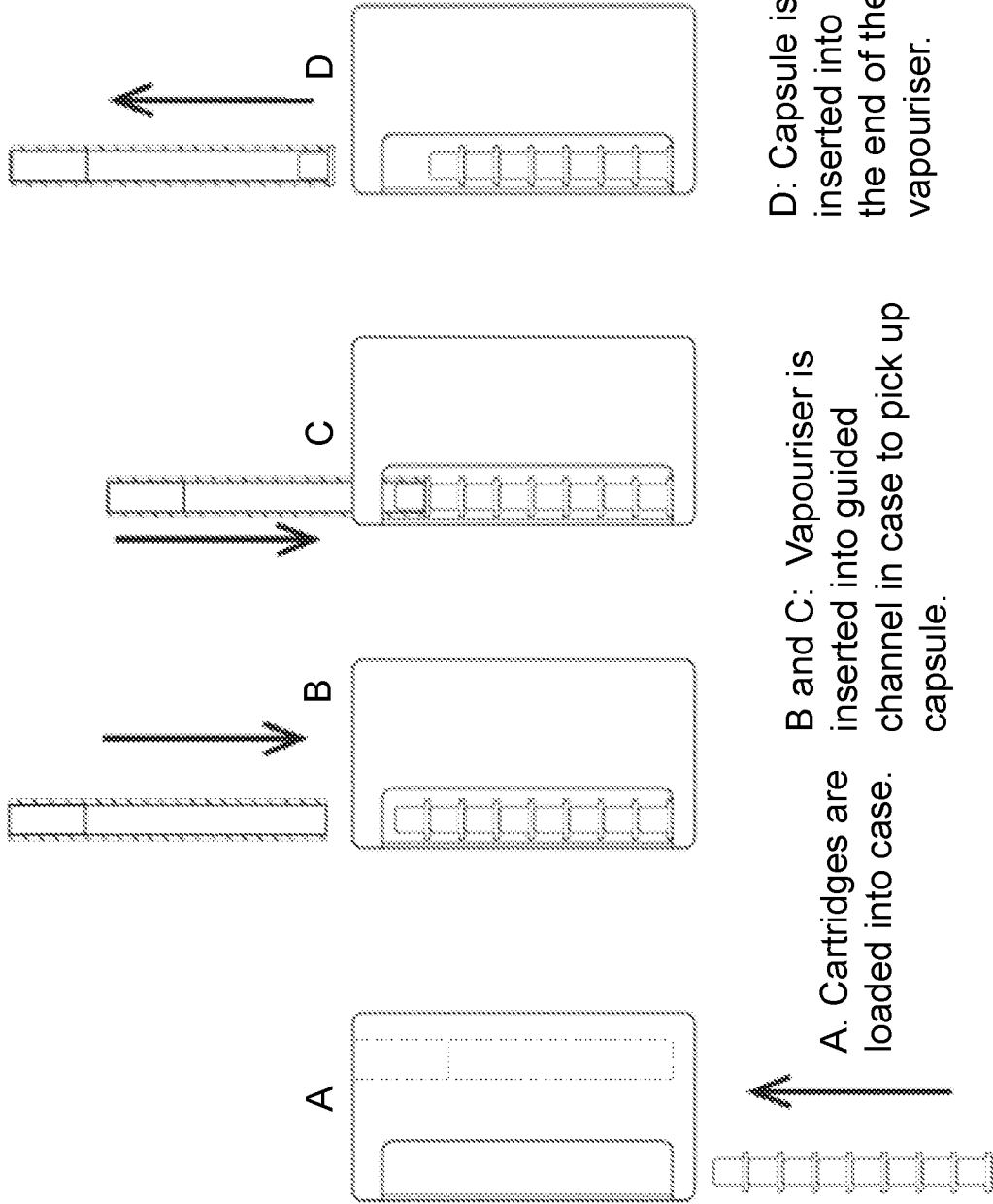

FIGURE 86



D: Capsule is inserted into the end of the vapouriser.

B and C: Vapouriser is inserted into guided channel in case to pick up capsule.

A. Cartridges are loaded into case.

FIGURE 87

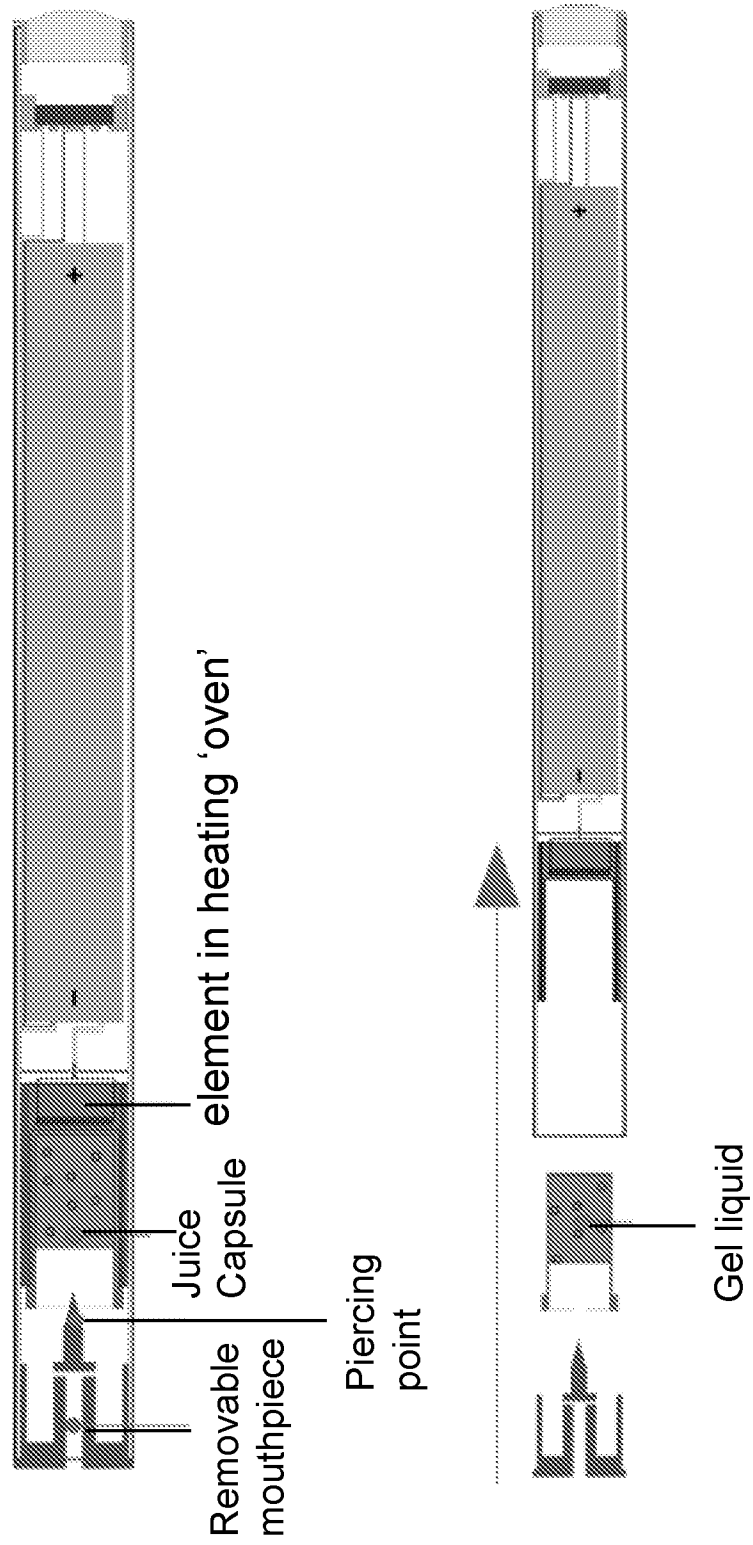

FIGURE 89

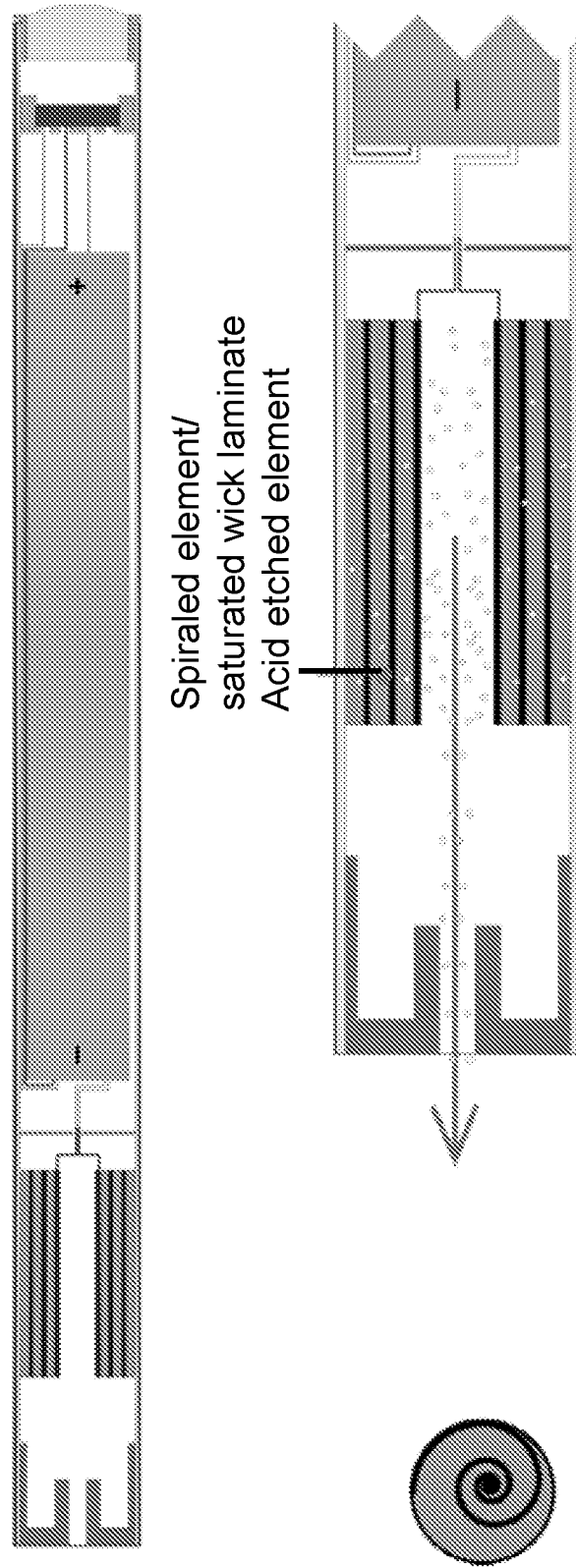

FIGURE 90

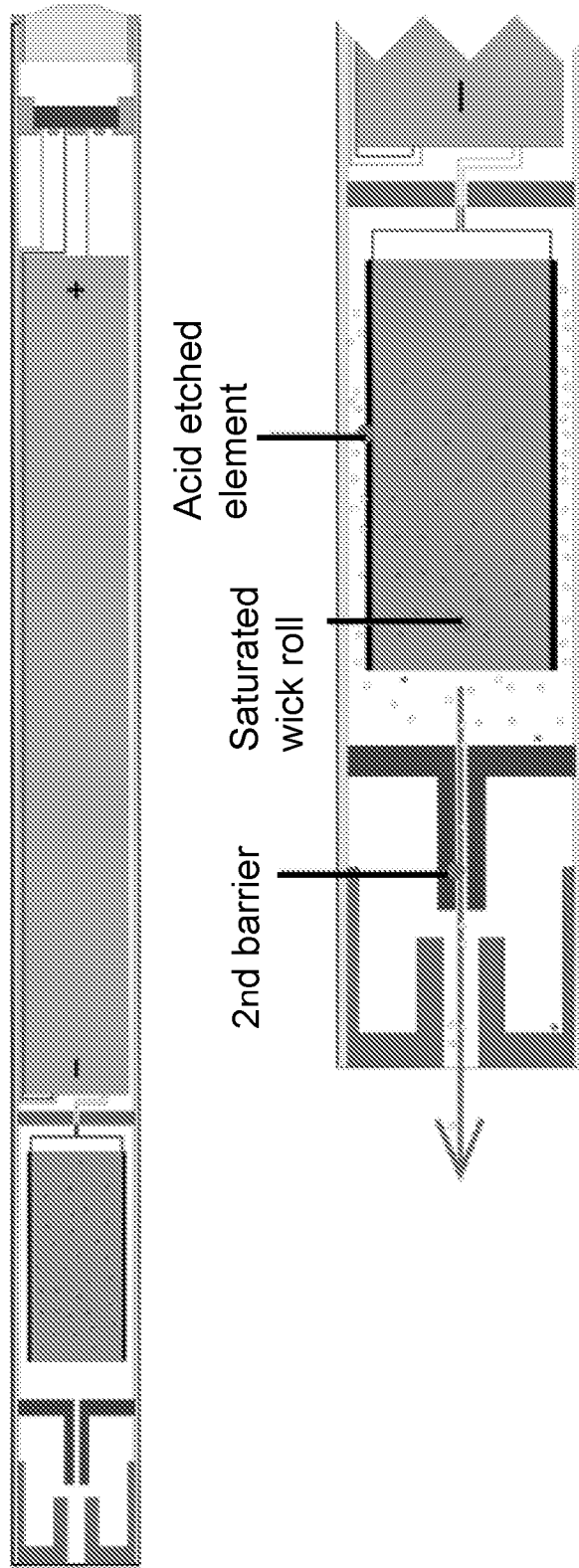

FIGURE 91

75/77

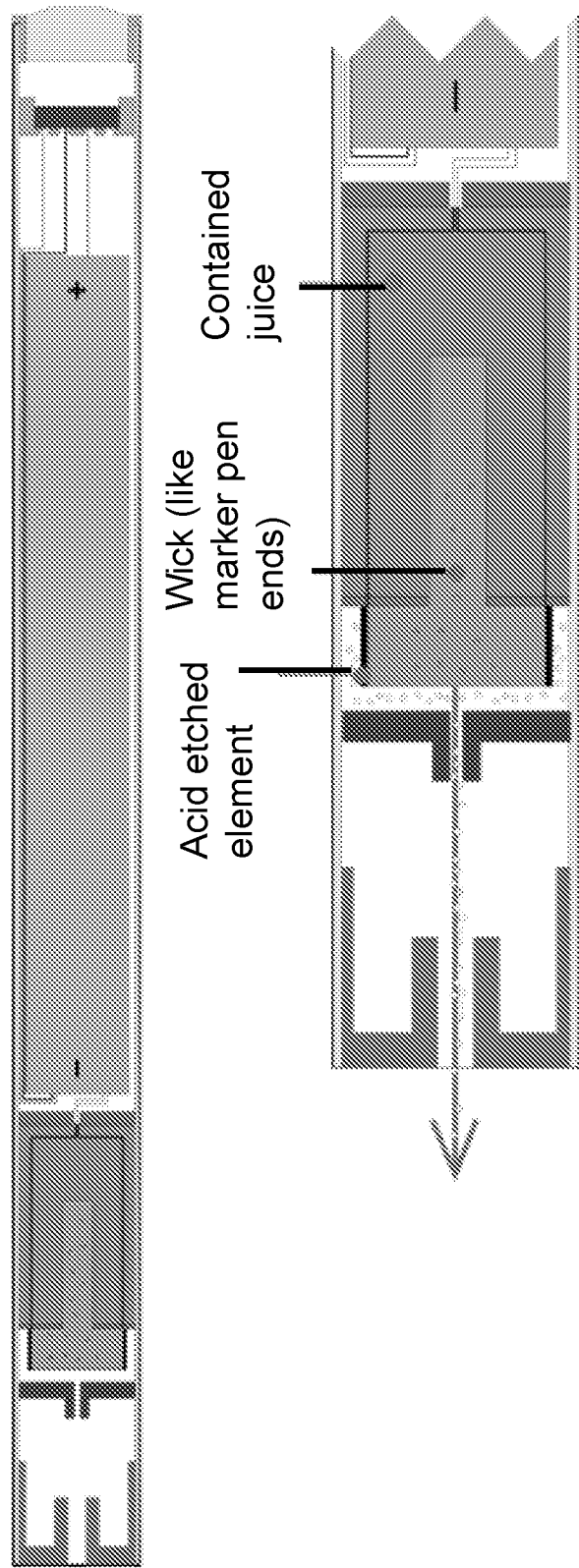

FIGURE 92

76/77

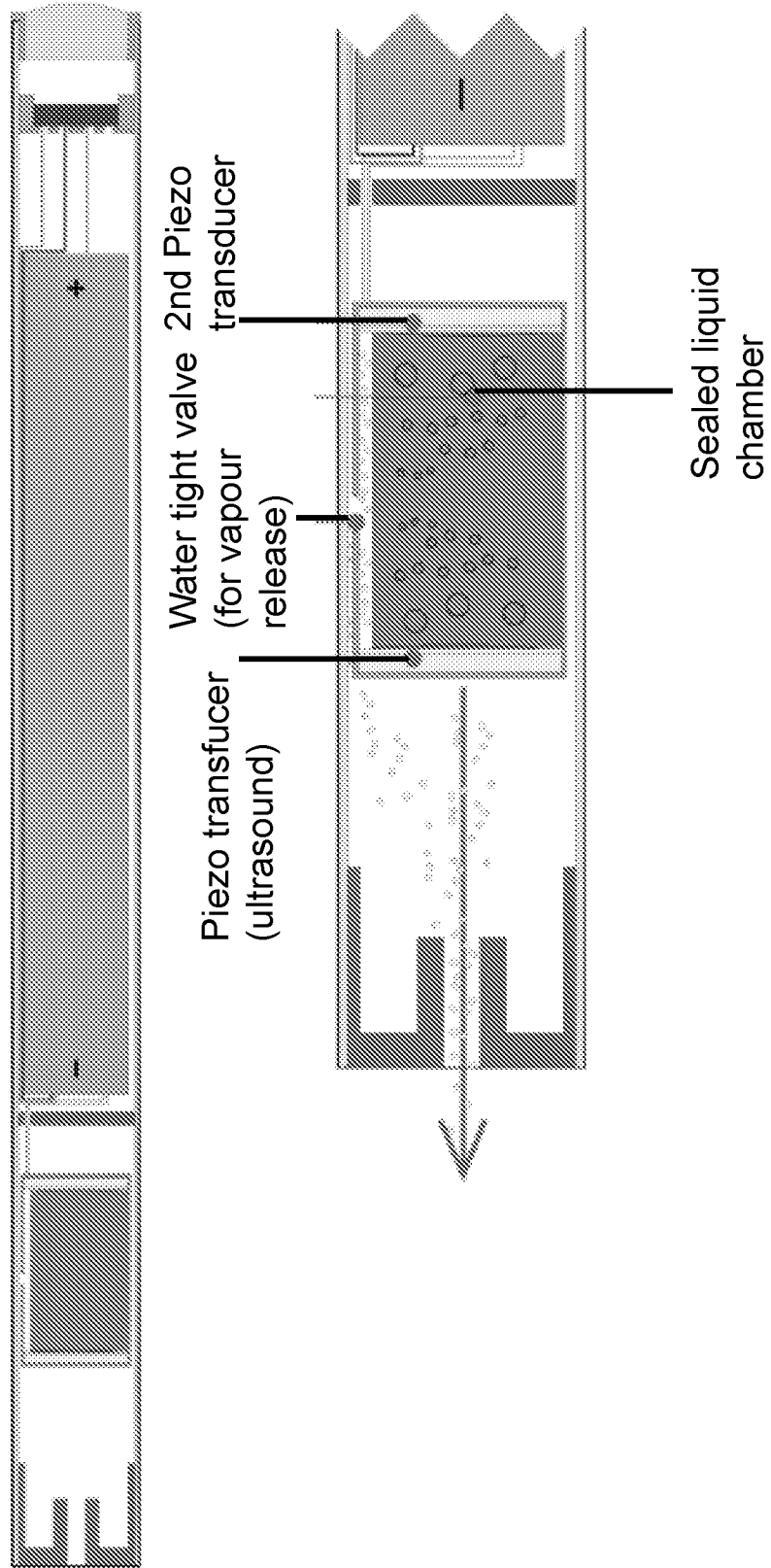

FIGURE 93

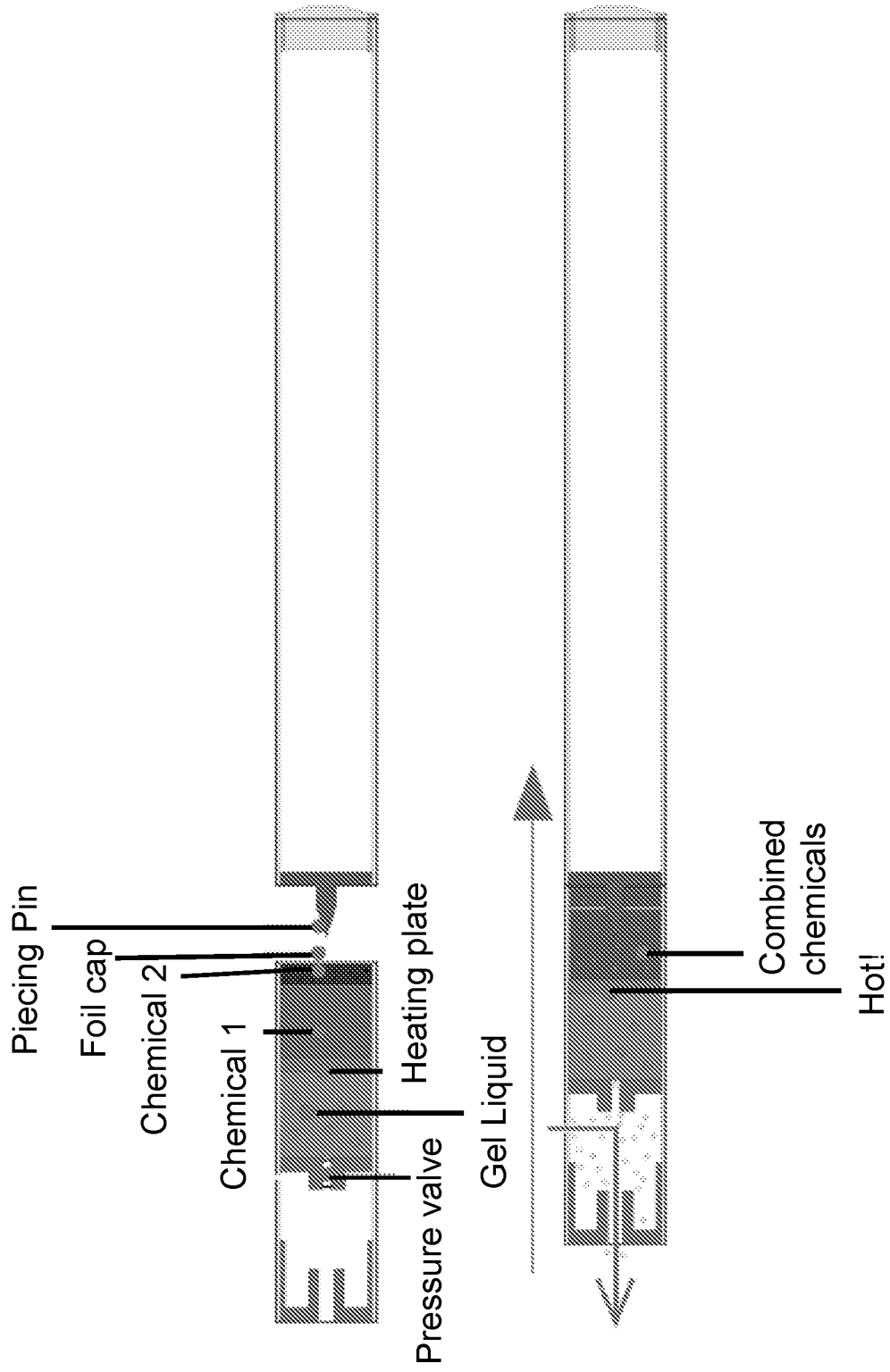

FIGURE 94

INTERNATIONAL SEARCH REPORT

International application No
PCT/GB2015/050574

A. CLASSIFICATION OF SUBJECT MATTER
INV. A24F47/00
ADD.

According to International Patent Classification (IPC) or to both national classification and IPC

B. FIELDS SEARCHED
Minimum documentation searched (classification system followed by classification symbols)
A24F

Documentation searched other than minimum documentation to the extent that such documents are included in the fields searched

Electronic data base consulted during the international search (name of data base and, where practicable, search terms used)
EPO-Internal, WPI Data

C. DOCUMENTS CONSIDERED TO BE RELEVANT

Category*	Citation of document, with indication, where appropriate, of the relevant passages	Relevant to claim No.
X	WO 2013/138384 A2 (UPTOKE LLC [US]) 19 September 2013 (2013-09-19) paragraph [0039] - paragraph [0042]; figures -----	1,2,31
X	US 2012/167906 A1 (GYSLAND DAVID [US]) 5 July 2012 (2012-07-05) the whole document -----	1,2,31
X	WO 2013/020220 A1 (WISPLITE TECHNOLOGY GROUP INC [CA]; TAGGART ANDREA [CA]; ORTEGA EDGAR) 14 February 2013 (2013-02-14) the whole document -----	1,2,31
A	US 2013/342157 A1 (LIU QIUMING [CN]) 26 December 2013 (2013-12-26) the whole document -----	1-31

Further documents are listed in the continuation of Box C.

See patent family annex.

* Special categories of cited documents :

- "A" document defining the general state of the art which is not considered to be of particular relevance
- "E" earlier application or patent but published on or after the international filing date
- "L" document which may throw doubts on priority claim(s) or which is cited to establish the publication date of another citation or other special reason (as specified)
- "O" document referring to an oral disclosure, use, exhibition or other means
- "P" document published prior to the international filing date but later than the priority date claimed

"T" later document published after the international filing date or priority date and not in conflict with the application but cited to understand the principle or theory underlying the invention

"X" document of particular relevance; the claimed invention cannot be considered novel or cannot be considered to involve an inventive step when the document is taken alone

"Y" document of particular relevance; the claimed invention cannot be considered to involve an inventive step when the document is combined with one or more other such documents, such combination being obvious to a person skilled in the art

"&" document member of the same patent family

Date of the actual completion of the international search 21 May 2015	Date of mailing of the international search report 01/06/2015
--	--

Name and mailing address of the ISA/ European Patent Office, P.B. 5818 Patentlaan 2 NL - 2280 HV Rijswijk Tel. (+31-70) 340-2040, Fax: (+31-70) 340-3016	Authorized officer MacCormick, Duncan
--	--

INTERNATIONAL SEARCH REPORT

Information on patent family members

International application No

PCT/GB2015/050574

Patent document cited in search report	Publication date	Patent family member(s)	Publication date
WO 2013138384 A2	19-09-2013	US 2013298905 A1 WO 2013138384 A2	14-11-2013 19-09-2013

US 2012167906 A1	05-07-2012	NONE	

WO 2013020220 A1	14-02-2013	AU 2012292915 A1 CA 2749077 A1 CA 2844787 A1 CN 104023775 A EP 2741801 A1 JP 2014528764 A KR 20140083983 A WO 2013020220 A1	27-03-2014 11-02-2013 14-02-2013 03-09-2014 18-06-2014 30-10-2014 04-07-2014 14-02-2013

US 2013342157 A1	26-12-2013	AU 2012383414 A1 CA 2877260 A1 CN 104010533 A EP 2865283 A1 KR 20150018627 A US 2013342157 A1 WO 2013189052 A1	22-01-2015 27-12-2013 27-08-2014 29-04-2015 23-02-2015 26-12-2013 27-12-2013
