

Nov. 26, 1935.

C. M. ALEXANDER
HEAT TRANSFER APPARATUS

2,022,173

Filed Feb. 18, 1931

3 Sheets-Sheet 1

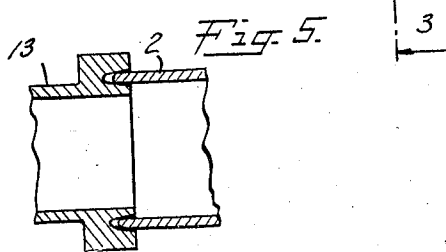
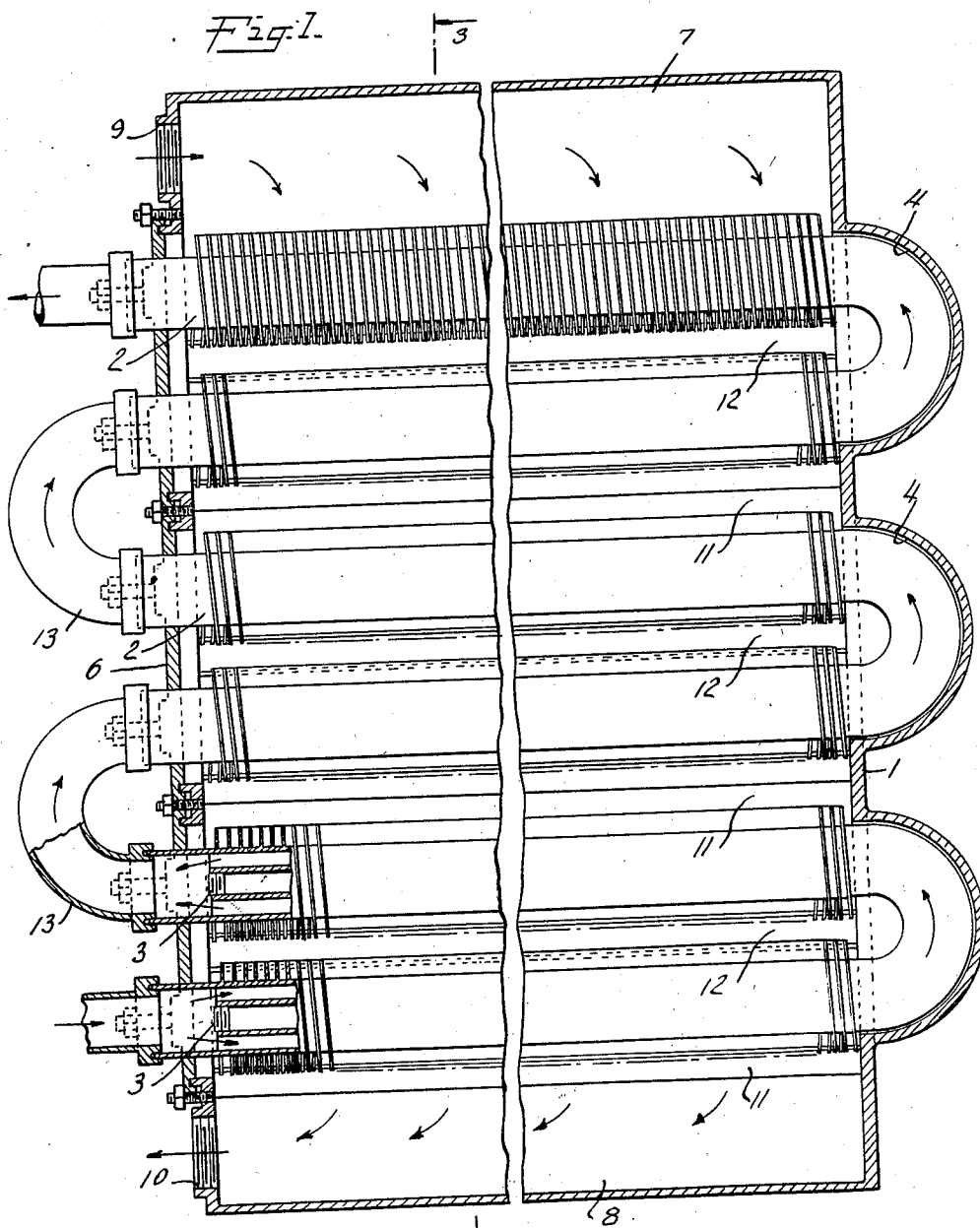

INVENTOR
Clive M. Alexander
BY
Penne, Davis, Munn & Almonda
ATTORNEYS

Nov. 26, 1935.

C. M. ALEXANDER
HEAT TRANSFER APPARATUS
Filed Feb. 18, 1931

2,022,173

3 Sheets-Sheet 2

Fig. 2.

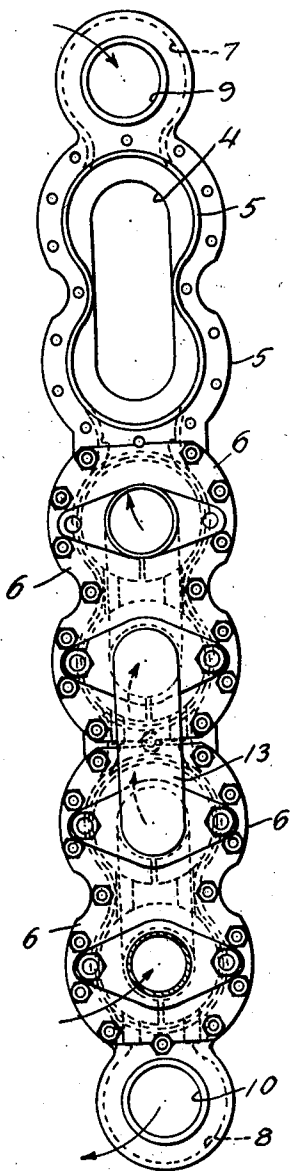

Fig. 3.

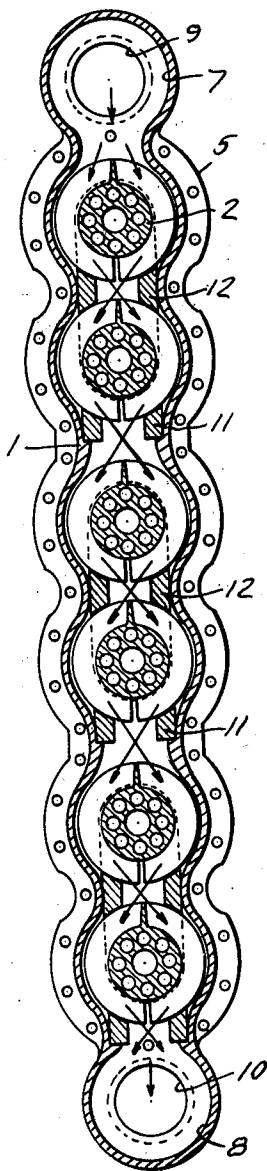
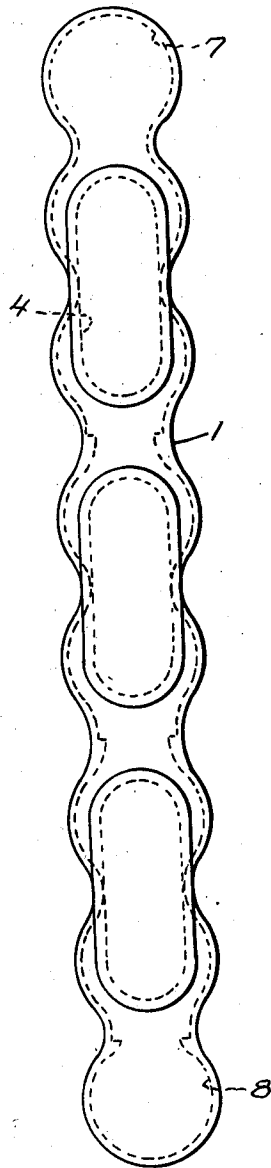

Fig. 4.



INVENTOR
Clive M. Alexander
BY
Perrine Davis, Rawlin & Edwards
ATTORNEYS.

Nov. 26, 1935.

C. M. ALEXANDER
HEAT TRANSFER APPARATUS

2,022,173

Filed Feb. 18, 1931

3 Sheets-Sheet 3

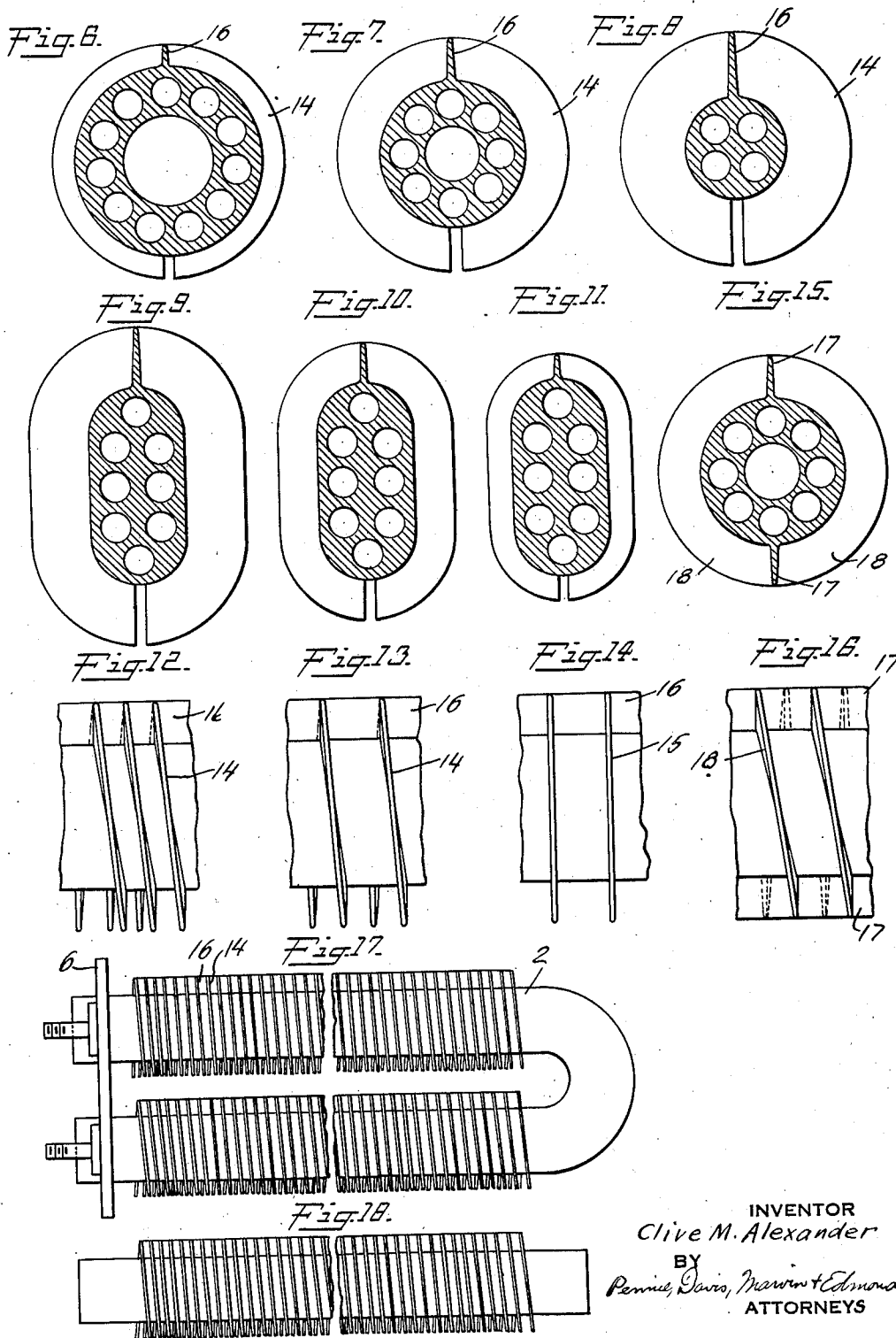

INVENTOR
Clive M. Alexander
BY
Perrin, Davis, Marwin & Edmunds
ATTORNEYS

UNITED STATES PATENT OFFICE

2,022,173

HEAT TRANSFER APPARATUS

Clive M. Alexander, Tulsa, Okla.

Application February 18, 1931, Serial No. 516,598

10 Claims. (Cl. 257—230)

This invention relates to improvements in heat transferring apparatus. More particularly, the invention relates to an apparatus adapted for use in indirect heat exchanging operations involving the transfer of heat from one fluid to another. The invention includes an improved heat transferring element as well as a complete assembly including two or more of the improved heat transferring elements of the invention.

The invention provides improved heat transfer apparatus in which the ratio of the flow area and the surfaces exposed to the fluids between which heat is to be transferred is maintained at the value most advantageous for the particular fluids concerned, regardless of whether the service involves the transfer of heat from a gas to a liquid, from a vapor to a liquid, from one liquid to another liquid, or from a gas to a vapor or vice versa. The invention also provides an apparatus in which the velocity of flow of both fluids may be maintained at a value most advantageous for the transfer of heat from that fluid to a fixed surface, irrespective of the ratio of the surfaces exposed to the fluids.

The improved heat transferring element of the present invention comprises an integral elongated base member having a plurality of relatively small passages extending longitudinally therethrough. The provision of a plurality of relatively small passages increases the internal surface available for heat transfer in relation to the cross-sectional area and makes practical increased velocity of fluid flow for turbulence. The relatively small passages are advantageously arranged at approximately equal distances from the periphery of the base member so that heat transmitted to the outer surface will be approximately equally distributed to the several passages and vice versa. A series of outwardly extended fins are spaced along the periphery of the base member to increase its external surface and to direct and distribute the flow of fluid contacting with the exterior surface.

The improved assembly of the invention comprises a group of two or more of the improved heat transferring elements parallelly arranged within a jacket, designed to conform approximately to the lateral surfaces of the group of heat transferring elements, and removable connecting means joining the adjacent extremities of the heat transferring elements as hereinafter more fully described. The assembled apparatus is of exceptionally simple and rugged construction which provides for easy access to the interior of the assembly. The interior of any of the im-

proved heat transferring elements is also readily accessible without necessitating its removal from the jacket. It is a further advantage of the improved heat transfer apparatus of the invention that the fins surrounding the base members and the jacket, arranged to approximately conform to the lateral surfaces of the heat transferring elements, co-operate to promote uniform distribution of the fluid contacting with the external surface of the heat transferring elements and to confine a fluid flowing transversely to the axis of the heat transferring elements so as to assure maximum efficiency of the heat transferring surfaces around the entire periphery of the heat transferring elements.

The invention will be further described in connection with the accompanying drawings which illustrate several modified forms of apparatus embodying the invention and further advantages of the invention will be apparent from this further description, but it is intended and will be understood that the invention is illustrated thereby and not limited thereto. In the drawings:

Fig. 1 is an elevation, partly in section and with parts broken away, of a completely assembled heat exchanger embodying the invention and including several of the improved heat transferring elements of the invention.

Fig. 2 is an elevation from the left side of the apparatus shown in Fig. 1 with the upper U shaped heat transferring element and its cover plate removed.

Fig. 3 is a sectional view of the assembly shown in Fig. 1 taken along line 3—3.

Fig. 4 is an elevation from the right side of the assembly shown in Fig. 1.

Fig. 5 is a fragmentary sectional view illustrating one of the joints between the heat transferring elements and the exterior return bend connections.

Figs. 6, 7 and 8 are transverse sections of a group of heat transferring elements adapted for different services with the same jacket.

Figs. 9, 10 and 11 are transverse sections of a similar group of heat transferring elements of a modified form.

Figs. 12, 13 and 14 are fragmentary elevations of heat transferring elements showing several different fin arrangements.

Figs. 15 and 16 show a transverse section and a fragmentary elevation, respectively, of one of the improved heat transferring elements embodying another modified and novel fin arrangement.

Fig. 17 is an elevation of one of the U-shaped

heat transferring elements illustrated in Fig. 1 when removed from the jacket.

Fig. 18 is an elevation of a simplified form of heat transferring element embodying the invention.

The assembled heat exchanger illustrated in Figs. 1 to 4 comprises a jacket 1 in which a row of U shaped heat transferring elements 2 are arranged. The heat transferring elements shown in this assembly are of the type illustrated in Figs. 6, 7 and 17, which include a base member having a single passage extending longitudinally along the central axis and a plurality of relatively small longitudinal passages spaced around the central passage at an approximately equal distance from the periphery of the base member. In an assembly of the type illustrated in Figs. 1 to 4 including heat transferring elements provided with a central passage, the central passage is preferably closed at both ends, for example, by plugs 3, to restrict the fluid flow to the relatively small outer passages in order that the transfer of heat to or from the fluid within the passages may be more uniformly distributed and in order that the fluid within the passages may be brought in closer proximity to the other heat interchanging fluid. A number of fins or flanges are spaced along the outer surface of the base member. These fins or flanges may advantageously be arranged, as shown, to form an interrupted helix. This type of fin or flange arrangement is described in U. S. Patent No. 1,658,025, issued to Clive M. Alexander, February 7, 1928.

The lateral sides of the jacket 1 are corrugated and symmetrically arranged so that the alternate extended and indented surfaces will conform approximately to the lateral surfaces of the row of heat transferring elements. The transverse distance between the indented portions of the corrugated side walls of the jacket is sufficiently great to permit the U bends at the inner extremities of the heat transferring elements to pass between them so that the heat transferring elements may be inserted or withdrawn from the jacket as desired. The interior of the jacket is provided at one end with recesses 4 adapted to receive the bent ends of the heat transferring elements. The other end of the jacket is provided with a flange 5 to which the cover plates 6, adjacent the outer ends of the heat transferring elements, are secured. The jacket extends above and below the row of heat transferring elements to form distributing chambers 7 and 8. At one or both ends of the jacket and communicating with the distributing chambers tapped openings 9 and 10 are provided to permit a fluid heating or cooling medium to be introduced into and discharged from the jacket. Baffles 11 and 12 (Fig. 3) serve the dual purpose of supporting the heat transferring elements in spaced relation and of co-operating with the corrugated side walls of the jacket to direct the fluid flow around the heat transferring elements in order to promote effective heat transfer through the surfaces between adjacent heating elements as well as through the lateral surfaces of these elements. Where the U bend type of heat transferring element is employed alternate pairs of baffles may advantageously be supported in recesses in the inner walls of the jacket so that lower heat transferring elements may be removed from the jacket without disturbing higher ones. Adjacent extremities of successive heat transferring elements are connected by return bends 13 which are secured to the cover plates 6 and held firmly against

the end of the heat transferring elements. These return bends are of large diameter so that when they are removed the interior of all of the relatively small passages extending through the heat transferring elements is accessible for inspection and cleaning. The relatively small passages may be readily cleaned, for example, merely by removing the exterior return bend connections and inserting a tube cleaner. Rattling of the inner tube surface in this manner naturally will shake incrustations off of the outer fins. However, when access to the outer surface of any one of the heat transferring elements becomes necessary the cover plate may be removed and the heating element withdrawn. It will be noted that in the illustrated assembly all joints are outside of the jacket so that intermingling of fluids through leaky joints is precluded.

The simplified form of heat transferring element illustrated in Fig. 18 may be used in place of the U bend elements, if desired. However, the use of this simpler form of heating element in an assembly similar to that illustrated in Figs. 1-4 would require a more complicated jacket structure with cover plates and removable connections at both ends of the jacket and the provision of means to compensate for expansion. Straight heat transferring elements of the type having a central passage, however, may advantageously be arranged to permit fluid flow in one direction through the relatively small outer passages with return flow through the central passages thereby entirely eliminating connections between adjacent heating elements at one end. The improved heat transferring elements of the invention of either the U form or the simpler form, may be used in furnaces or boxes without the provision of a special jacket. Various arrangements can be made of multiple lengths and widths to adapt the heat transferring elements to the container so as to obtain efficient heat transfer.

The group of heating elements shown in Figs. 6 to 8 inclusive are all adapted for use for different services with the same jacket. The outside diameter of the fins or flanges is the same in each instance so that any one of them may be substituted for any other one where it is desirable to change the heat transferring service, for example, from liquid to liquid service to gas to liquid service. Thus an assembly equipped with the type of heat transferring elements illustrated in Fig. 6 is adapted for service involving the transfer of heat from one liquid to another liquid and may have, for example, a ratio of external surface to internal surface of $1\frac{3}{4}$ to 1, excluding the internal surface of the central passage. The ratio of the external flow area to the internal flow area in an assembly equipped with this type of heating element may be about 9 to 1 excluding the flow area of the central passage. A similar assembly but with the elements illustrated in Fig. 7 substituted for the elements illustrated in Fig. 6 would be advantageously adapted for service involving the transfer of heat between a vapor and a liquid. The ratio of external surface to internal surface in such an assembly advantageously may be about $3\frac{1}{2}$ to 1 and the ratio of flow areas, external to internal, about 25 to 1, excluding the central passages in both instances. A similar assembly equipped with the heat transferring elements illustrated in Fig. 8 would be advantageously adapted for service involving the transfer of heat between a gas and a liquid. The

ratio of external to internal surface in such an assembly advantageously may be about 9 to 1 and the ratio of flow areas, external to internal, about 76 to 1. It will be obvious that in each of the above services the fluid supplied to the interior of the heat transferring element is a liquid. However, although a liquid is used as one of the fluids in each case in the specific group of heat transferring elements referred to above, it will be obvious that a similar group may be used for heat transferring operations between vapors and gases wherein no liquid is involved.

Figs. 9, 10 and 11, illustrate modified forms of heat transferring elements in which the transverse section of the base member is oval shaped and the central passage is eliminated. The elements of this group may be adapted to different services in the same manner as the elements illustrated in Figs. 8, 7 and 6, respectively. The elements illustrated in Figs. 9 to 11 however, are not interchangeable in the same jacket, although the base member is the same throughout the group so that the same connections may be used.

Figs. 12 to 16 show fragmentary views of heat transferring elements with different fin arrangements, each of which has special advantages. These fin arrangements are shown as applied to heat transferring elements of circular cross-section but they are equally adaptable to elements of oval section. The fin arrangements shown in Figs. 12 and 13 consist of flanges 14 forming approximately one complete turn, more or less, of a helix. These flanges are positioned along the base member so as to form an interrupted helix as described in Alexander Patent No. 1,658,025. In the fin arrangement shown in Fig. 12, the flanges are positioned somewhat closer together than the pitch of the helix so that the flanges overlap, while in the arrangement shown in Fig. 13 successive flanges are positioned at distances somewhat greater than the pitch of the helix.

The fin arrangement illustrated in Fig. 14 consists of a series of annular flanges 15 which are joined by a longitudinal spacing web 16 extending along the upper surface of the element. This web arrangement is also used to advantage with the helical flanges and serves the dual purpose of strengthening the transverse flanges and promoting a more even distribution of the fluid contacting with the outer surfaces of the heat transferring elements. This longitudinal web is advantageously positioned along the edges of the heating elements with which the fluid passing over the heat transferring elements first contacts.

Figs. 15 and 16 illustrate a transverse section and fragmentary elevation, respectively, of a heat transferring element provided with a novel segmental fin arrangement. This fin arrangement consists of two longitudinal webs 17 along opposite sides of the heat transferring element with spaced transverse flanges 18 extending around the heat transferring element between the longitudinal webs. This form of fin arrangement has the advantage that a heat transferring element equipped therewith is symmetrical while at the same time the uniform distribution and turbulence effected by the interrupted helical fin structure is obtained to a great extent.

The improved heat transferring elements of the present invention may be formed of cast metal, for example, iron, steel or aluminum. However, for extremely high temperature service heat transferring elements may be constructed of a tube bundle positioned around a central tube with the outer fins cast or pressed on the tube bundle.

I claim:

1. An improved heat transferring element comprising an integral base member bent in the form of a U having relatively long straight sections, a plurality of relatively small passages extending longitudinally through each of said straight sections and a passage through the bent portion of the base member connecting the relatively small passages in the straight sections, a plurality of generally transverse fins spaced longitudinally along the straight sections of said base member and extending outwardly from the outer surface thereof and a longitudinal web extending along one side of each of said straight sections between the transverse fins, said longitudinal webs being arranged in the plane including the axes of both straight sections and extending outwardly from the surface of the straight sections in the same direction.

2. An improved heat transferring element comprising an integral base member bent in the form of a U having relatively long straight sections, a plurality of relatively small passages extending longitudinally through each of said straight sections and a passage through the bent portion of the base member connecting the relatively small passages in the straight sections, a plurality of generally transverse fins spaced longitudinally along the straight sections of said base member and extending outwardly from the outer surface thereof and longitudinal webs extending along the upper and lower sides of said straight sections between the transverse fins.

3. In heat transferring apparatus the improvement comprising the combination of a jacket having symmetrically corrugated lateral walls, a plurality of elongated heat transferring elements with connections therebetween, successive elongated heat transferring elements being positioned parallel to the corrugations in the lateral side walls of the jacket and centrally located between outwardly extending corrugations, and inlet and outlet openings in said jacket communicating directly with the space surrounding said heat transferring elements, said openings being oppositely spaced beyond said heat transferring elements.

4. In heat transferring apparatus the improvement comprising the combination of a jacket having symmetrically corrugated lateral walls, a plurality of elongated integral heat transferring elements each having a plurality of relatively small passages extending longitudinally there-through, connections between the ends of adjacent heat transferring elements, successive elongated heat transferring elements being positioned parallel to the corrugations in the lateral side walls of the jacket and centrally located between outwardly extending corrugations, and inlet and outlet openings in said jacket communicating directly with the space surrounding said heat transferring elements.

5. In heat transferring apparatus the improvement comprising the combination of a jacket having symmetrically corrugated lateral walls, inlet and outlet openings in said jacket, a plurality of elongated heat transferring elements with connections therebetween, successive elongated heat transferring elements being positioned parallel to the corrugations in the lateral side walls of the jacket and centrally located between outwardly extending corrugations, and baffles between successive heat transferring elements adapted to support the heat transferring 75

elements and to restrict the width of the jacket between the heat transferring elements.

6. In heat transferring apparatus, the improvement comprising an improved heat transferring element comprising an integral base member bent in the form of a U having relatively long straight sections, a plurality of relatively small passages extending longitudinally in each of said straight sections and positioned at substantially the same distance from the periphery of the straight sections, at least one passage through the bent portion of the base member connecting the relatively small passages in the straight sections, a transverse cover plate surrounding both of the straight sections near their free ends, and means for directing and confining the flow of fluid in one direction through said straight sections to said plurality of relatively small passages.

7. In heat transferring apparatus, the improvement comprising an improved heat transferring element comprising an integral base member bent in the form of a U having relatively long straight sections, a plurality of relatively small passages extending longitudinally through each of said straight sections and positioned at substantially the same distance from the periphery of said straight sections, at least one passage through the bent portion of the base member connecting the relatively small passages in the straight sections, and means for directing and confining the flow of fluid in one direction through said straight sections to said plurality of relatively small passages.

8. In heat transferring apparatus, the improvement comprising an improved heat transferring element comprising an integral base member bent in the form of a U having relatively long straight sections, a plurality of relatively small passages extending longitudinally through each of said straight sections and positioned at substantially the same distance from the periphery thereof, at least one passage through the bent portion of said base member connecting the relatively small passages in the straight sections, a plurality of generally transverse fins spaced longitudinally along the straight sections of said

base member and extending outwardly from the outer surface thereof, and means for directing and confining the flow of fluid in one direction through said straight sections to said plurality of relatively small passages.

9. In heat transferring apparatus, the improvement comprising an improved heat transferring element comprising an integral base member bent in the form of a U having relatively long straight sections, a plurality of relatively small passages extending longitudinally through each of said straight sections and positioned at substantially the same distance from the periphery thereof, at least one passage through the bent portion of the base member connecting the relatively small passages in the straight sections, a plurality of generally transverse fins spaced longitudinally along the straight sections of said base member and extending outwardly from the outer surface thereof, a transverse cover plate surrounding both of the straight sections near their free ends, and means for directing and confining the flow of fluid in one direction through said straight sections to said plurality of relatively small passages.

10. In heat transferring apparatus, the improvement comprising the combination of a jacket having symmetrically corrugated lateral walls, a plurality of elongated heat transferring elements comprising integral base members each having a plurality of relatively small passages extending longitudinally therethrough, connections between the ends of adjacent heat transferring elements, successive elongated heat transferring elements being positioned parallel to the corrugations in the lateral side walls of the jacket and centrally located between the outwardly extending corrugations, a plurality of generally transverse fins positioned longitudinally along said base members and extending outwardly from the outer surface thereof, and inlet and outlet openings in said jacket communicating directly with the space surrounding said heat transferring elements.

CLIVE M. ALEXANDER.