

S. GRAY.  
 APPARATUS FOR ACTUATING WATER MOTORS.  
 APPLICATION FILED JUNE 7, 1910.

1,002,676.

Patented Sept. 5, 1911.

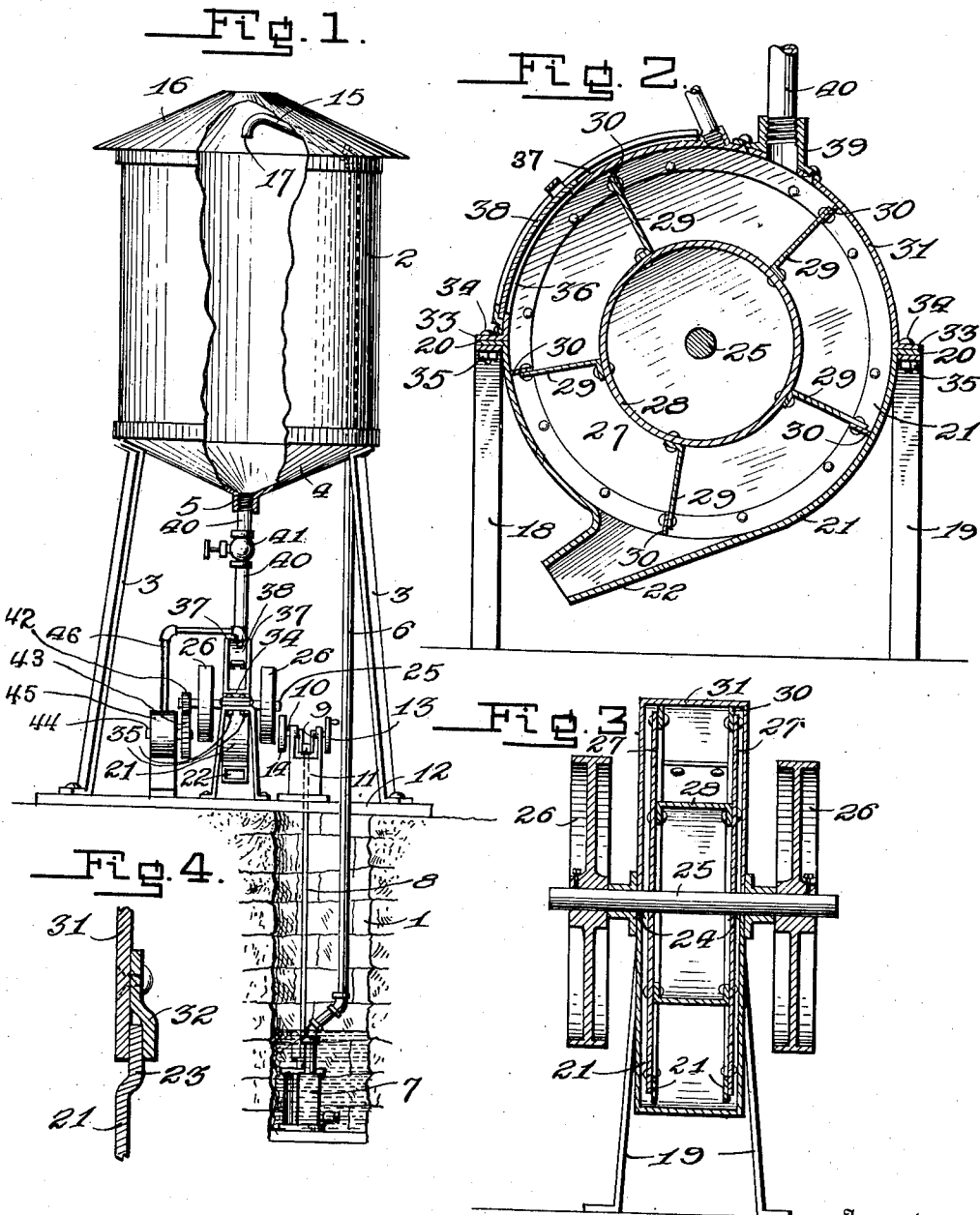

Inventor  
 Stephen Gray,

Witnesses

*Everett Lancaster.*  
*H. John Doyle.*

By *E. C. Broome*  
 his Attorney.

# UNITED STATES PATENT OFFICE.

STEPHEN GRAY, OF CALUMET, OKLAHOMA.

APPARATUS FOR ACTUATING WATER-MOTORS.

1,002,676.

Specification of Letters Patent.

Patented Sept. 5, 1911.

Application filed June 7, 1910. Serial No. 565,496.

*To all whom it may concern:*

Be it known that I, STEPHEN GRAY, a citizen of the United States of America, residing at Calumet, in the county of Canadian and State of Oklahoma, have invented certain new and useful Improvements in Apparatus for Actuating Water-Motors, of which the following is a specification, reference being had therein to the accompanying drawing.

This invention relates to hydraulic motors and the means for operating the same, and the principal object of the same is to provide a water tank which receives water from a well or other source of supply and which has a pipe communication with a motor so that water from said tank will operate said motor, means being provided whereby the motor may be caused to operate suitable machines, and means being also provided whereby the water may be discharged from the motor after operating the same.

In carrying out the objects of the invention generally stated above it will be understood, of course, that the essential features thereof are necessarily susceptible of changes in details and structural arrangements, one preferred and practical embodiment of which is shown in the accompanying drawings, wherein:—

Figure 1 is a view in elevation, partly in section, of the improved motor and its source of water supply. Fig. 2 is a central vertical sectional view of the motor. Fig. 3 is a vertical sectional view taken on the line 3—3, Fig. 2. Fig. 4 is a fragmentary sectional view showing the meeting edges of the sectional casing of the motor.

Referring to said drawings by numerals, 1 designates a well or other source of water supply over which a tank 2 is retained in an elevated position, by the standards 3. Said tank has a conical bottom 4 provided with a central, pendent discharge tube 5 that is threaded. A supply pipe 6 has one end portion extended into the well and suitably connected to the discharge outlet of a pump cylinder 7 which is submerged in said well. A sucker rod 8 extends from said cylinder to the crank 9 of an operating shaft 10 mounted in a suitable standard 11 carried by the well cover 12. Said shaft has a crank handle 13 at one end by means of which it may be manually operated, and a pulley 14 at its other end adapted for belt connection with a source of power. Supply pipe 5 ex-

tends into tank 2 through the bottom thereof and is arranged parallel with the side of the tank and has its upper end portion 15 bent toward the center of the tank beneath the conical top 16 which is fitted air-tight over the tank. The upper portion of pipe 5 terminates in a pendent discharge outlet 17 which is arranged directly over the discharge outlet of tank 2.

Front and rear standards 18—19 are carried by well cover 12 and have the forward and rear outwardly projecting flanges 20 of a semicylindrical casing section 21 rested on their top portions. Said casing is provided at its lower portion with an outwardly inclined longitudinally tapering discharge nozzle 22. Said casing section is open at the top and its longitudinal edges are offset, as indicated at 23, and provided with a central bearing recess 24. A shaft 25 is rotatably mounted in said bearing recesses, said shaft having its ends projecting beyond the sides of said casing section 21 and equipped with pulleys 26, adapted for belt connection with suitable machines. A water wheel is mounted on the central portion of said shaft, said wheel comprising relatively spaced side plates 27 which are connected by the annular flange 28 which forms the base of said wheel. Wings or buckets 29 radiate from said base 28 and have their free outer ends provided with a flexible strip of material 30, such as leather.

An upper casing section 31 similar in shape to lower casing section 21 is provided with bearing recesses in its sides complementary to the recesses of said section 21 to permit section 31 to be placed over shaft 25. The longitudinal edges of the open end of section 31 are provided with an outstanding flange 32 which overlaps the offset edge of section 21, as shown in Fig. 4, to seal the joints between the longitudinal edges of said sections. Section 31 is provided with forward and rear outstanding flanges 33 which are placed in overlapping contact with the similar flanges of section 21 and by means of bolts 34 and lock nuts 35, the flanges of said sections are rigidly, but detachably fastened to the standards 18—19. Section 31 has an air opening 36 in its top portion, the longitudinal edges of said opening being provided with guiding strips 37. A cover 38 is provided for the opening 36, said cover being slidably mounted in the guide strips 37 and adapted to be moved therein to cover

or uncover opening 36, thereby regulating the supply of air to the interior of the casing. The upper portion of said section 31 is also provided with an upstanding inlet tube 5 39 that is in vertical alinement with the discharge tube 5 carried by the bottom of tank 2. A pipe 40 connects tube 5 with tube 39, said pipe being provided with a controlling valve 41.

10 In operation, the tank is filled with water by means of the pump and pipe 6 and when it is desired to operate the motor, valve 41 is opened so that the water from said tank will be discharged through pipe 40 into the 15 water wheel, causing the water wheel to rotate so that power may be taken therefrom through pulleys 26. The water, after rotating said wheel, is discharged away from the motor through nozzle 22 and may be used 20 for irrigation or other purposes.

It will be seen from the foregoing, that the upper section 31 may be readily removed to permit access to be had to the water wheel, or to permit the water wheel and its shaft 25 to be removed, and also that the end strips of the blades or buckets 29 prevent air from passing over or around said blades except when they are passing over the entrance to nozzle 22. And it will also be seen that the 30 opening 36 in the casing section 31 permits air to enter the casing to take the place of the air that has been displaced by the water, and that the slide for said opening regulates the amount of air admitted.

35 The operation of the water wheel as set forth above is limited by the capacity of the tank 2, but it will be understood that by

operating the pump with the valve 41 open, a constant supply of water may be delivered to the water wheel so that a continuous operation of the wheel may be obtained. 40

As is shown more clearly in Fig. 1, the motor shaft 25 is provided with a gear 42 at one end that meshes with a similar gear 43 carried by the shaft 44 of an air pump or compressor 45. Said pump has a pipe connection 46 with the upper portion of casing section 31 so that the blast of air from said pipe will assist the motor in revolving and also cause the water to be discharged under 50 pressure from nozzle 22.

What I claim as my invention is:—

A water motor comprising a casing provided with an upper water inlet, an upper air inlet adjacent the water inlet, and a 55 lower water discharge, said casing being provided with an opening in its upper surface, guiding means at the longitudinal edges of said opening, a manually adjustable slide conforming to the contour of said casing and movably engaging said guiding means, a 60 water wheel rotatable in said casing, an overhead water supply tank having a water conveying connection with said inlet, an air compressor having a pipe connection with 65 said air inlet, and means actuated by said water wheel for operating the air compressor.

In testimony whereof I hereunto affix my signature in presence of two witnesses.

STEPHEN GRAY.

Witnesses:

J. I. PHELPS,  
M. B. COXE.