

(12) INTERNATIONAL APPLICATION PUBLISHED UNDER THE PATENT COOPERATION TREATY (PCT)

(19) World Intellectual Property
Organization
International Bureau



(43) International Publication Date
12 December 2013 (12.12.2013)

(10) International Publication Number
WO 2013/183011 A2

- (51) International Patent Classification: Not classified
- (21) International Application Number: PCT/IB2013/054627
- (22) International Filing Date: 5 June 2013 (05.06.2013)
- (25) Filing Language: English
- (26) Publication Language: English
- (30) Priority Data: 61/656,708 7 June 2012 (07.06.2012) US
- (71) Applicant: INTAL TECH LTD. [IL/IL]; 5 Ben David Shlomo St, 7536215 Rishon Le-Zion (IL).
- (72) Inventor: VASILEVSKY, Alexander; 12/13 Frank Zvi, 75660 Rishon Lezion (IL).
- (74) Agents: S. FRIEDMAN & CO. et al.; P.O. Box 33123, 2 Weizmann St., 6133101 Tel Aviv (IL).
- (81) Designated States (unless otherwise indicated, for every kind of national protection available): AE, AG, AL, AM, AO, AT, AU, AZ, BA, BB, BG, BH, BN, BR, BW, BY,

BZ, CA, CH, CL, CN, CO, CR, CU, CZ, DE, DK, DM, DO, DZ, EC, EE, EG, ES, FI, GB, GD, GE, GH, GM, GT, HN, HR, HU, ID, IL, IN, IS, JP, KE, KG, KN, KP, KR, KZ, LA, LC, LK, LR, LS, LT, LU, LY, MA, MD, ME, MG, MK, MN, MW, MX, MY, MZ, NA, NG, NI, NO, NZ, OM, PA, PE, PG, PH, PL, PT, QA, RO, RS, RU, RW, SC, SD, SE, SG, SK, SL, SM, ST, SV, SY, TH, TJ, TM, TN, TR, TT, TZ, UA, UG, US, UZ, VC, VN, ZA, ZM, ZW.

(84) Designated States (unless otherwise indicated, for every kind of regional protection available): ARIPO (BW, GH, GM, KE, LR, LS, MW, MZ, NA, RW, SD, SL, SZ, TZ, UG, ZM, ZW), Eurasian (AM, AZ, BY, KG, KZ, RU, TJ, TM), European (AL, AT, BE, BG, CH, CY, CZ, DE, DK, EE, ES, FI, FR, GB, GR, HR, HU, IE, IS, IT, LT, LU, LV, MC, MK, MT, NL, NO, PL, PT, RO, RS, SE, SI, SK, SM, TR), OAPI (BF, BJ, CF, CG, CI, CM, GA, GN, GQ, GW, KM, ML, MR, NE, SN, TD, TG).

Published:

— without international search report and to be republished upon receipt of that report (Rule 48.2(g))



WO 2013/183011 A2

(54) Title: ELECTRONIC EQUIPMENT BUILDING BLOCKS FOR RACK MOUNTING

(57) Abstract: A rack-mountable module assembly, comprising: a plurality of electronic equipment modules, each having a height in multiples of approximately 1.75 inches and a width in multiples of approximately 1.75 inches; a plurality of connectors configured to form a horizontal row of said plurality of electronic equipment modules, by connecting every two adjacent modules of said plurality of electronic equipment modules to each other; and a pair of side mounts configured to connect the horizontal row to a frame of the rack.

ELECTRONIC EQUIPMENT BUILDING BLOCKS FOR RACK MOUNTING

FIELD OF THE INVENTION

The invention relates to electronic equipment building blocks for rack mounting.

5

BACKGROUND

A rack is often defined as a standardized frame or enclosure for mounting multiple electronic equipment modules, such as network equipment, computer servers, audio/video equipment and/or the like. Racks typically come in one of two sizes: 19-inch or 23-inch. This size refers to the *width* of the equipment that can be mounted inside the rack. Differently-sized racks are also possible.

10

A rack unit "U" (sometimes also referred to as "RU") is a unit of measurement defining the *height* of equipment intended for mounting in a rack. One rack unit, as accepted today, is 1.75 inches (44.45 mm) high. Rack equipment is usually manufactured with a height in multiples of U, such as "1U", "2U" and so on. A typical full-size rack measures 44U, while a typical "half-height" rack, or "half-rack", would usually have a *height* of between 18U and 24U. The term "half-rack", however, may be used differently in different situations. For example, "half-rack" may refer to equipment *width*; a "half-rack" equipment module may have a width of 9.5 inches (half of 19 inches) or 11.5 inches (half of 23 inches). In other situations, "half-rack" may refer to equipment *depth*, namely – two "half-rack" modules may be mounted one behind the other.

15

20

Formal standards for the more common 19-inch (482.6 mm) rack include the following, which are incorporated herein by reference in their entirety:

- Electronic Industries Alliance EIA-310-D, Cabinets, Racks, Panels, and Associated Equipment, dated September 1992. (Latest Standard Now REV E 1996).
- Consumer Electronics Association CEA-310-E design requirements for Cabinets, Panels, Racks and Subracks, dated December 14, 2005.
- International Electrotechnical Commission - IEC 60297 Mechanical structures for electronic equipment.

25

30

- Deutsches Institut für Normung DIN 41494.

SUMMARY

The following embodiments and aspects thereof are described and illustrated in
5 conjunction with systems, tools and methods which are meant to be exemplary and
illustrative, not limiting in scope.

There is provided, in accordance with an embodiment, a rack-mountable module
assembly, comprising: a plurality of electronic equipment modules, each having a height
in multiples of approximately 1.75 inches and a width in multiples of approximately 1.75
10 inches; a plurality of connectors configured to form a horizontal row of said plurality of
electronic equipment modules, by connecting every two adjacent modules of said plurality
of electronic equipment modules to each other; and a pair of side mounts configured to
connect the horizontal row to a frame of the rack.

There is further provided, in accordance with an embodiment, a rack-mountable
15 module assembly, comprising: a plurality of electronic equipment modules, each having a
height in multiples of approximately 1.75 inches and a width in multiples of
approximately 1.75 inches; a horizontal back panel extending to an entire width of the
rack and configured to connect to a frame of the rack; and a plurality of connectors
configured to form a horizontal row of said plurality of electronic equipment modules, by
20 connecting each of said plurality of electronic equipment modules to said horizontal back
panel.

In some embodiments, said plurality of connectors comprises a plurality of back-
access connectors, thereby providing for a clean appearance of a front side of the
horizontal row.

25 In some embodiments, said plurality of back-access connectors comprises a plurality
of I-shaped connectors.

In some embodiments, each of said plurality of H-shaped connectors comprises at
least four holes, and wherein the assembly further comprises at least four screws for each
for of said plurality of I-shaped connectors, wherein said at least four screws are
30 configured for threading from a back side of the rack, through two electronic equipment

modules of said plurality of electronic equipment modules, and into said at least four holes.

In some embodiments, at least some of said plurality of connectors are further configured to vertically mount one or more additional electronic equipment modules to said horizontal row.

In some embodiments, said horizontal row, together with said pair of side mounts, are configured to match a rack having a width of approximately 19 inches.

In some embodiments, said horizontal row, together with said pair of side mounts, are configured to match a rack having a width of approximately 23 inches.

In some embodiments, at least some of said plurality of electronic equipment modules each has a cubic shape.

In some embodiments, at least some of said plurality of electronic equipment modules each comprises a peg and a cover connected to said peg.

In some embodiments, each of said plurality of electronic equipment modules comprises one or more plugs selected from the group consisting of: a Universal Serial Bus (USB) plug, an RJ45 plug and a power plug.

In some embodiments, said plurality of electronic equipment modules comprises at least one USB-to-serial adapter.

In some embodiments, said plurality of electronic equipment modules comprises at least one power-over-Ethernet injector.

In some embodiments, said plurality of electronic equipment modules comprises at least one network switch.

In some embodiments, the rack-mountable module assembly further comprises a vertical back panel configured to vertically mount one or more additional electronic equipment modules to said horizontal row.

In some embodiments, said horizontal back panel comprises at least one vertical protrusion configured for mounting one or more additional electronic equipment modules to said horizontal row.

In some embodiments, said horizontal back panel is configured to match a rack having a width of approximately 19 inches.

In some embodiments, said horizontal back panel is configured to match a rack having a width of approximately 23 inches.

In addition to the exemplary aspects and embodiments described above, further aspects and embodiments will become apparent by reference to the figures and by study of
5 the following detailed description.

BRIEF DESCRIPTION OF THE FIGURES

Exemplary embodiments are illustrated in referenced figures. Dimensions of components and features shown in the figures are generally chosen for convenience and
10 clarity of presentation and are not necessarily shown to scale. The figures are listed below.

Fig. 1 shows a perspective view of a rack with exemplary modules of electronic equipment which serve as building blocks;

Fig. 2 shows a front view of the rack of Fig. 1;

Fig. 3 shows a perspective view of an exemplary 1U² module;

15 Fig. 4 shows a perspective view of an exemplary 2U² module;

Fig. 5 shows a perspective view of an exemplary 3U² module;

Fig. 6 shows a perspective view of an exemplary 3U² module;

Fig. 7 shows a perspective view of an exemplary 4U² module; and

20 Figs. 8A-E show the exemplary 3U² module of Fig. 6 in top, side, front, cross-sectional and exploded views.

DETAILED DESCRIPTION

An aspect of some embodiments relates to modules of electronic equipment which are structured and sized to serve as building blocks for mounting in a rack. Each module
25 may have a width smaller than the standard 19 or 23 inches-wide rack, such that multiple modules, either ones of the same type or of different types, may be mounted in the rack *side-by-side*. A further aspect relates to advantageous connectors structured for connecting adjacent modules. These modules and connectors, alone or in combination, enable the highly-modular mounting of similar or different electronic modules; the modules may be
30 assembled together using the connectors, for filling a standard 19 or 23 inch width

according to the user's preferences and needs. Removal or replacement of a mounted module is convenient and efficient.

Reference is now made to Figs. 1 and 2, which show a rack with an exemplary assembly of modules connected to its frame, in exploded and front views, respectively.

5 The components of this exemplary assembly, as well as their positioning, are shown as an illustrative example only. Due to the high modularity of the disclosed modules and connectors, numerous other options are possible.

Optionally, the *height* of some or all of the disclosed modules is approximately ($\pm 10\%$) U or multiples of U . Further optionally, the *width* of some or all of the disclosed
10 modules is approximately U or multiples of U . In some embodiments, such as in the example of Figs. 1 and 2, the height of the modules is U , and their width is U or multiples of U . Accordingly, modules of these embodiments may be referred to as measuring U^2 or its multiples ($2U^2$, $3U^2$ etc.). The depth dimension of such modules may be of any measurement, U or different. For example, modules **110**, **112** and **114**, as well as the other
15 modules of a first horizontal row **102**, measure U^2 (height \times width). Ten such modules are shown, for a total width of approximately $10U$ (17.5 inch). Since the shown rack is of a 19 inch width, approximately 1.5 inches remain. However, since each of the modules may be *approximately* U -wide, their actual width may be slightly larger than exactly U , such that the 19 inches are reached. Additionally or alternatively, a pair of side mounts, such as side
20 mounts **122** and **124** may be provided, and may close any remaining gaps by connecting the two most extreme modules in each row to the frame of the rack. Similar considerations apply when the rack is 23 inches.

A second horizontal row **130** of modules may include, as an example, a $1U^2$ module **132**, a $3U^2$ module **134**, a $4U^2$ module **136** and a $1U^2$ module **138**. A third horizontal row
25 **140** of modules may be comprised of three $3U^2$ modules **142**, **144** and **146**, and a $1U^2$ module **148**.

In some embodiments, the attachment of the modules to one another and/or their fixation to the rack may be made using special connectors, such as I-shaped connectors
150 and **152** of second row **130** and connectors **160** and **162** of third row **140**. This type of
30 connectors may be referred to as "back access" connectors, since they require access to the back side of the rack for threading screws, such as screws **164**, **165**, **166** and/or **167**,

through each module and into the connector. This may be desired, for example, when a clean appearance of the front side of the rack and the horizontal row of modules is needed; the connectors hide the screws.

In some embodiments, the fixation of the modules to the rack may be made using a
5 back panel, such as back panel **170**, which extends to the entire width of the rack and connects to it on both sides. Then, modules such as modules **110**, **112** and **114**, as well as other modules of first row **102**, may be affixed to back panel **170** using screws, such as screws **172**, **174**, **176** and/or **178**, which are threaded from the front side of the rack. The appearance of first row **102** may be less appealing than that of second **130** and third **140**
10 rows which use the back access connectors, but mounting and mounting of modules may be easier in the case of first row **102**, where front access is enabled.

In some embodiments (not shown), a rack-mountable assembly of modules may also include vertical mounting of modules, instead of or in addition to the horizontal-only mounting discussed above.

15 If the attachment of the modules to one another is done by connectors, for example as by connectors similar to connectors **150**, **152**, **160** and **162**, such connectors and their associated modules may be configured to connect modules one above or below the other, vertically.

If the attachment of the modules to one another is done by connecting them to a back
20 panel which holds them together, for example a back panel similar to back panel **170**, then such back panel may be configured to connect modules one above or below the other, vertically. Namely, such back panel may be shaped as a horizontal panel with one or more vertical protrusions, erecting upwards or downwards. Additionally or alternatively, one or more separate, vertical back panels, may be used to connect modules one above or below
25 the other.

Reference is now made to Fig. 3, which shows an exemplary $1U^2$ module **300**, which may be, for example, module **114** of Figs. 1 and 2, having an RJ45 socket **302** and a mini USB socket **304**, serving here merely as an example. Module **300** may have a generally cubic shape. One or more corners of module **300** may have a recess, such as recess **306**,
30 extending from a front facet **308** of the module towards the back of the module. Recess **306** may include two differently-leveled plateaus, a high plateau **312** and a low plateau

314. Low plateau **314** may have a bore **316** through which a screw may be threaded from the front or the back, depending if front access or back access is desired.

A vertical surface **313** between plateaus **312** and **314** may serve as a support for a connector connecting between module **300** and an adjacent module. Referring now back to
5 Fig. 1, an exemplary connector, such as an I-shaped connector **150**, may include two top protrusions **150a-b** and two bottom protrusions **150c-d**. One or more of each of top protrusions **150a-b** and bottom protrusions **150c-d** may include a bore (not shown), extending from a back side **107a** of the connector towards the front, but ending within the body of the connector and not exiting from its front facet **107b**. A screw may be threaded
10 through a back side of a module, such as module **300**, and into the bore, to affix the module to the connector. When an adjacent module is connected to opposite protrusions of the same connector, each protrusion presses against vertical surface **313** of each of the modules, preventing them, together with the screw, from spreading apart. Persons of skill in the art will recognize that the I-shaped connector discussed here is merely an example
15 of many types of connectors which may be used to connect adjacent modules and/or connect an end module to the rack.

Figs. 4, 5, 6 and 7 show additional, exemplary types of electronic modules which are structured, similar to the above discussions, based on the U^2 principle.

Fig. 4 shows a $2U^2$ module having 4 USB sockets, one mini USB socket and a
20 power socket. This module may serve, for instance, as a USB hub.

Fig. 5 shows a $3U^2$ module having 4 RJ45 sockets and a mini USB socket. This module may serve, for example, as a USB-to-serial adapter.

Fig. 6 shows a $3U^2$ module having 3 RJ45 sockets, 2 USB sockets, a mini USB
25 socket and a power socket. This module may serve, for example, as a combined network switch/USB hub. Another option, for example, may be to use one of the RJ45 sockets for Ethernet and the other two, together with the USB sockets, as USB-to-serial adapters.

Fig. 7 shows a $4U^2$ module having 6 RJ45 sockets and a power socket. This module may serve, for example, as a network switch and/or a power-over-Ethernet injector.

Some or all of these exemplary modules and other, non-shown modules which are
30 based on the same U^2 principle, may have a same corner configuration, enabling the connection of two adjacent modules using the disclosed I-shaped connector or a different

connector. In addition, some or all of these exemplary modules and other, non-shown modules which are based on the same U^2 principle, may include one or more pegs, such as pegs **702** and **704** shown in Fig. 7. Such pegs may be provided on one or more sides of each module, and used to connect various covers, such as dust covers or the like, to the module. These covers may cover the various sockets on the front facet of the module, or sockets (invisible in the previous figures) at the back of each module.

Reference is now made to Figs. 8A-E, which demonstrate the structure and configuration of an exemplary $3U^2$ module **800**, similar to the $3U^2$ module of Fig. 6 which includes 3 RJ45 sockets, 2 USB sockets, one micro USB socket and a power socket. This $3U^2$ module is shown in multiple views, and serves here as an example of U^2 modules of different U-multiple widths.

Exemplary dust covers, such as those discussed above, are shown in these figures; for example, covers **802** and **804** of Fig. 8A.

Figs. 8A-E further shows, as an example, 3 RJ45 plugs, 2 USB plugs, one micro USB plug and a power plug, all connected to $3U^2$ module **800**. Both the plugs and their respective sockets may be of a hardened configuration, namely – be made of relatively rigid materials and structured to withstand conditions such as shock, dust and frequent manual connection and disconnection. Some or all of the plug types optionally include one or more screw fasteners, such as fasteners **806** and **808**, which thread into corresponding screw holes **810** and **812** (hidden) in module **800**. Matching circumferential seals, optionally of rubber or silicone. may be provided on each plug and its corresponding socket, to seal the electrical leads against dust, humidity and/or fluids.

In Fig. 8E, which is an exploded view of module **800**, a sealing feature of the back side of the module itself is shown. A seal cord **814**, made of rubber, silicone or the like may be positioned at least partially inside an open conduit in either a body **816** of module **800** or its bottom cover **818**. An elongated, closed-circuit protrusion may be positioned opposite to the conduit, either in body **816** or in bottom cover **818**, as may be the case, and have a matching shape. When bottom cover **818** is fastened to body **816**, seal cord **814** is pressed between the conduit and the protrusion and seals module **800**. The matching conduit-protrusion configuration may additionally provide enhanced EM

(electromagnetic) shielding, since the EM-permeable seal cord **814** is surrounded by the conduit and the protrusion, blocking EM waves.

Module **800** may have, in general, enhanced EM shielding qualities. At least body **816** of module **800**, and optionally its bottom cover **818**, may be made of CNC-processed
5 Aluminum (or a different suitable metal), so that solid material, with no gaps or non-hermetic connections, encompasses any electronic components residing inside the module.

In the description and claims of the application, each of the words “comprise” “include” and “have”, and forms thereof, are not necessarily limited to members in a list with which the words may be associated. In addition, where there are inconsistencies
10 between this application and any document incorporated by reference, it is hereby intended that the present application controls.

CLAIMS

What is claimed is:

1. A rack-mountable module assembly, comprising:
 - a plurality of electronic equipment modules, each having a height in multiples of approximately 1.75 inches and a width in multiples of approximately 1.75 inches;
 - a plurality of connectors configured to form a horizontal row of said plurality of electronic equipment modules, by connecting every two adjacent modules of said plurality of electronic equipment modules to each other; and
 - a pair of side mounts configured to connect the horizontal row to a frame of the rack.
2. The rack-mountable module assembly according to claim 1, wherein said plurality of connectors comprises a plurality of back-access connectors, thereby providing for a clean appearance of a front side of the horizontal row.
3. The rack-mountable module assembly according to claim 2, wherein said plurality of back-access connectors comprises a plurality of I-shaped connectors.
4. The rack-mountable module assembly according to claim 3, wherein each of said plurality of H-shaped connectors comprises at least four holes, and wherein the assembly further comprises at least four screws for each of said plurality of I-shaped connectors, wherein said at least four screws are configured for threading from a back side of the rack, through two electronic equipment modules of said plurality of electronic equipment modules, and into said at least four holes.
5. The rack-mountable module assembly according to claim 1, wherein at least some of said plurality of connectors are further configured to vertically mount one or more additional electronic equipment modules to said horizontal row.
6. The rack-mountable module assembly according to claim 1, wherein said horizontal row, together with said pair of side mounts, are configured to match a rack having a width of approximately 19 inches.

7. The rack-mountable module assembly according to claim 1, wherein said horizontal row, together with said pair of side mounts, are configured to match a rack having a width of approximately 23 inches.

8. The rack-mountable module assembly according to claim 1, wherein at least some of said plurality of electronic equipment modules each has a cubic shape.

9. The rack-mountable module assembly according to claim 1, wherein at least some of said plurality of electronic equipment modules each comprises a peg and a cover connected to said peg.

10. The rack-mountable module assembly according to claim 1, wherein each of said plurality of electronic equipment modules comprises one or more plugs selected from the group consisting of: a Universal Serial Bus (USB) plug, an RJ45 plug and a power plug.

11. The rack-mountable module assembly according to claim 1, wherein said plurality of electronic equipment modules comprises at least one USB-to-serial adapter.

12. The rack-mountable module assembly according to claim 1, wherein said plurality of electronic equipment modules comprises at least one power-over-Ethernet injector.

13. The rack-mountable module assembly according to claim 1, wherein said plurality of electronic equipment modules comprises at least one network switch.

14. A rack-mountable module assembly, comprising:

a plurality of electronic equipment modules, each having a height in multiples of approximately 1.75 inches and a width in multiples of approximately 1.75 inches;

a horizontal back panel extending to an entire width of the rack and configured to connect to a frame of the rack; and

a plurality of connectors configured to form a horizontal row of said plurality of electronic equipment modules, by connecting each of said plurality of electronic equipment modules to said horizontal back panel.

15. The rack-mountable module assembly according to claim 14, further comprising a vertical back panel configured to vertically mount one or more additional electronic equipment modules to said horizontal row.

16. The rack-mountable module assembly according to claim 14, wherein said horizontal back panel comprises at least one vertical protrusion configured for mounting one or more additional electronic equipment modules to said horizontal row.

17. The rack-mountable module assembly according to claim 14, wherein said horizontal back panel is configured to match a rack having a width of approximately 19 inches.

18. The rack-mountable module assembly according to claim 14, wherein said horizontal back panel is configured to match a rack having a width of approximately 23 inches.

19. The rack-mountable module assembly according to claim 14, wherein at least some of said plurality of electronic equipment modules each has a cubic shape.

20. The rack-mountable module assembly according to claim 14, wherein at least some of said plurality of electronic equipment modules each comprises a peg and a cover connected to said peg.

21. The rack-mountable module assembly according to claim 14, wherein each of said plurality of electronic equipment modules comprises one or more plugs selected from the group consisting of: a Universal Serial Bus (USB) plug, an RJ45 plug and a power plug.

22. The rack-mountable module assembly according to claim 14, wherein said plurality of electronic equipment modules comprises at least one USB-to-serial adapter.

23. The rack-mountable module assembly according to claim 14, wherein said plurality of electronic equipment modules comprises at least one power-over-Ethernet injector.

24. The rack-mountable module assembly according to claim 14, wherein said plurality of electronic equipment modules comprises at least one network switch.

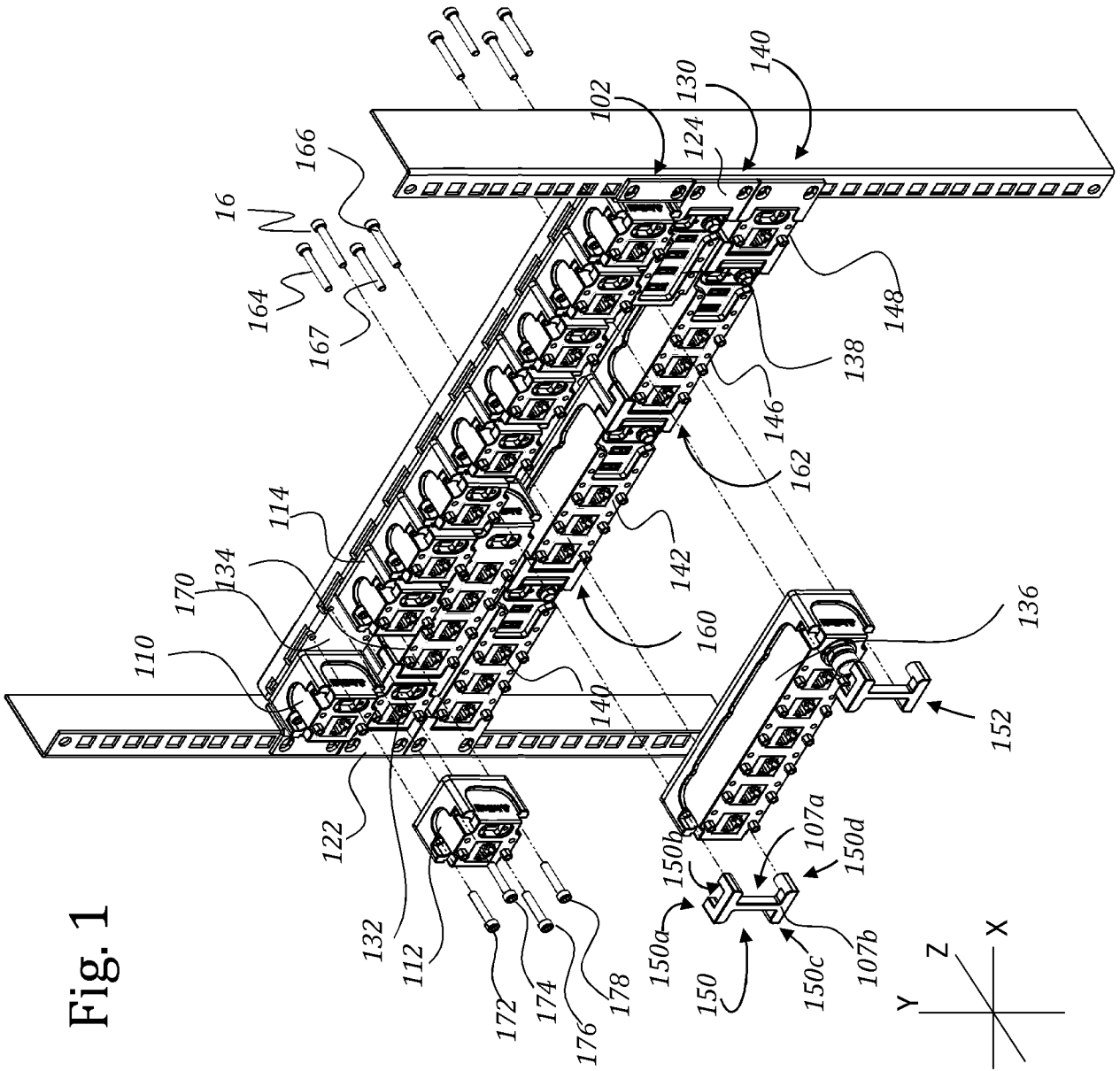

Fig. 1

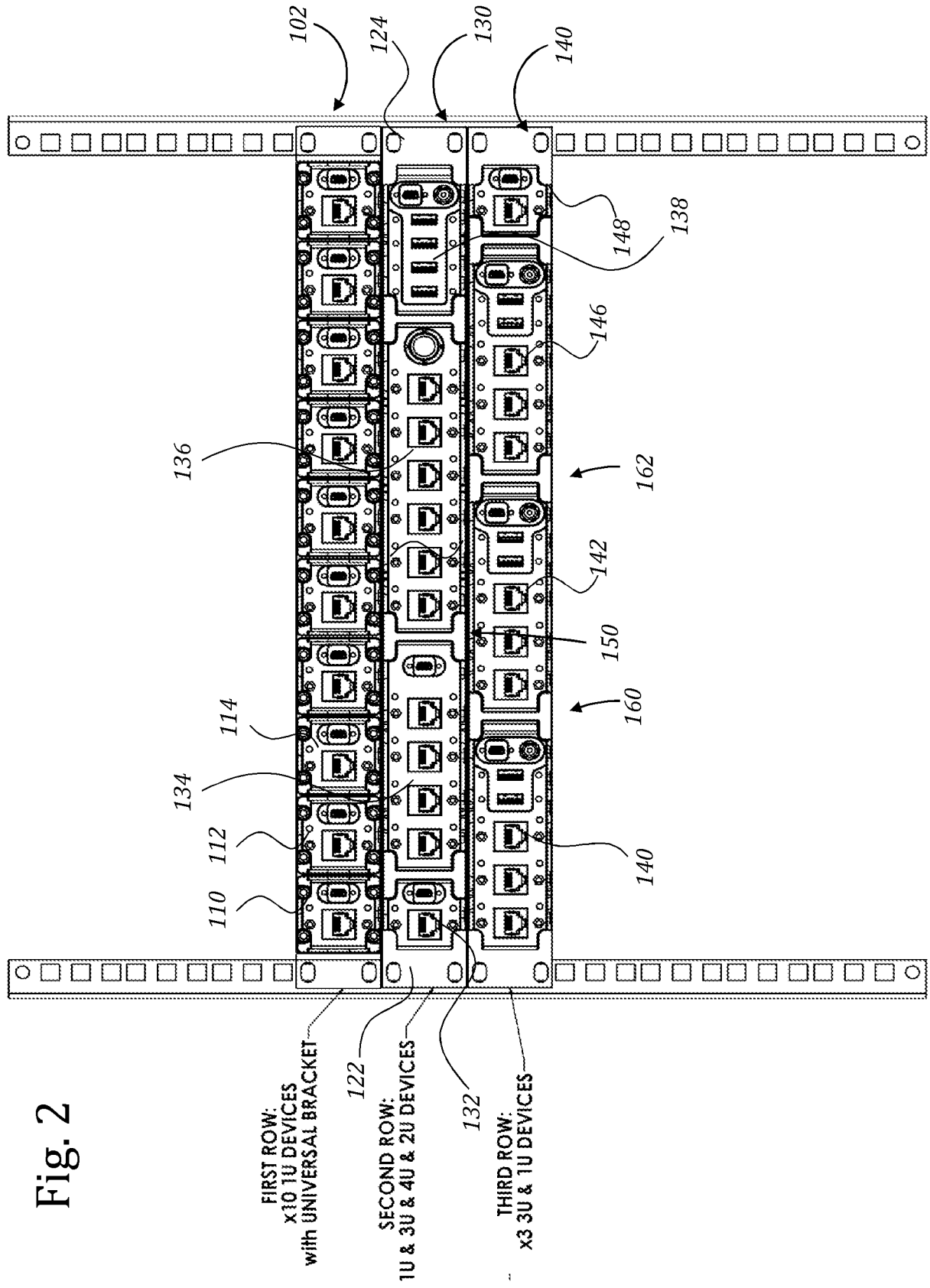
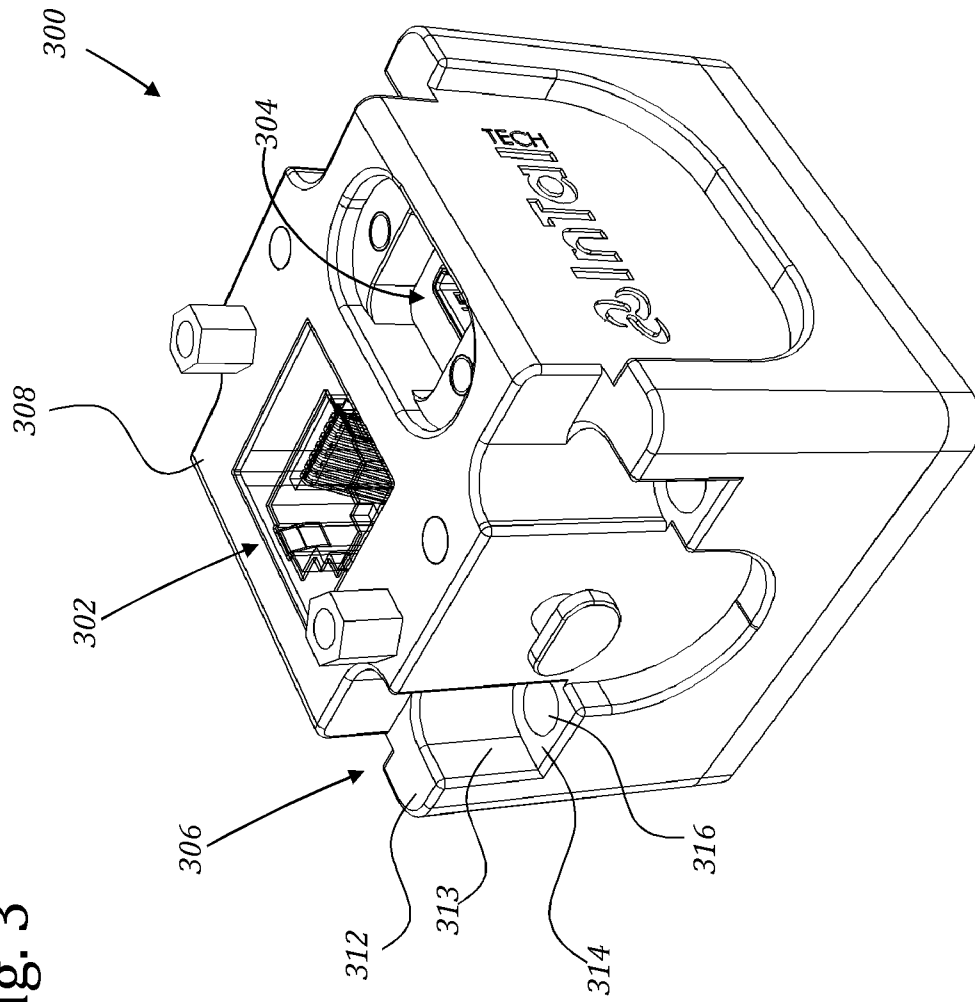

Fig. 3



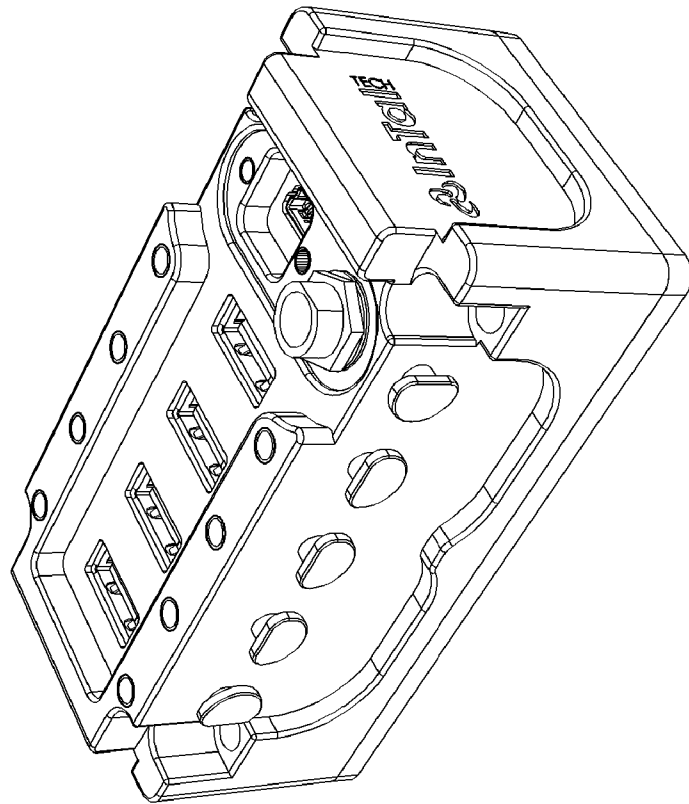

Fig. 4

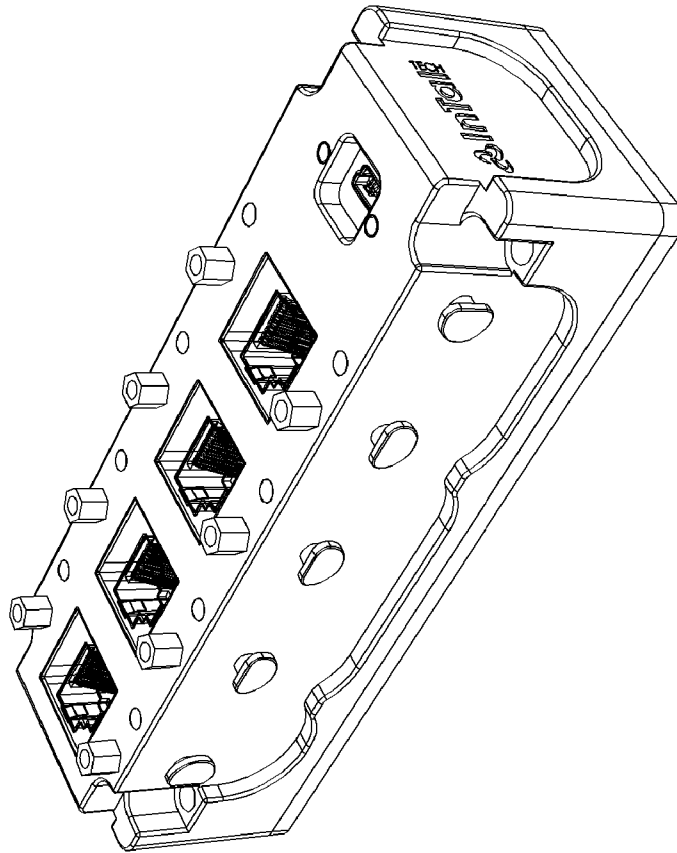

Fig. 5

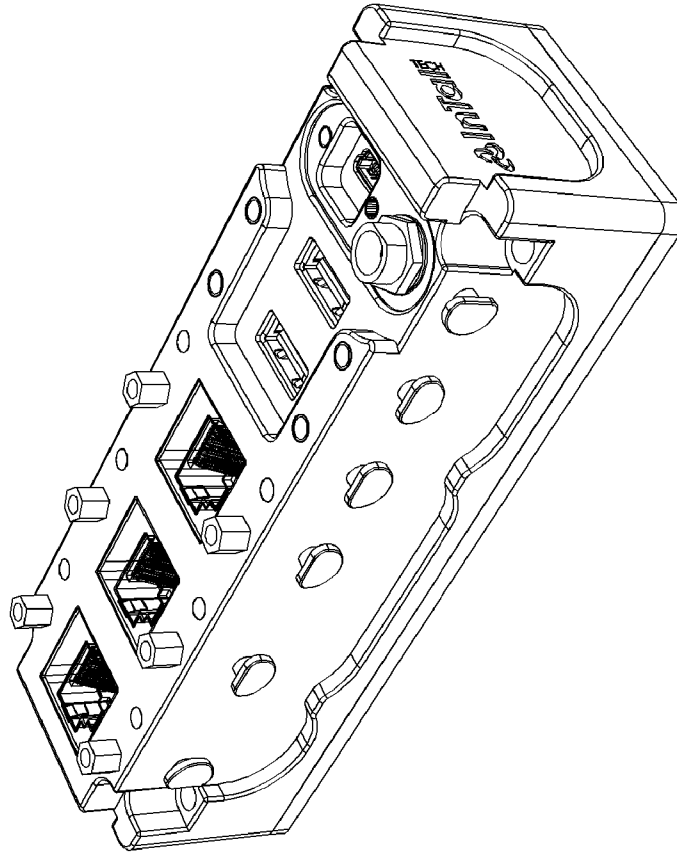

Fig. 6

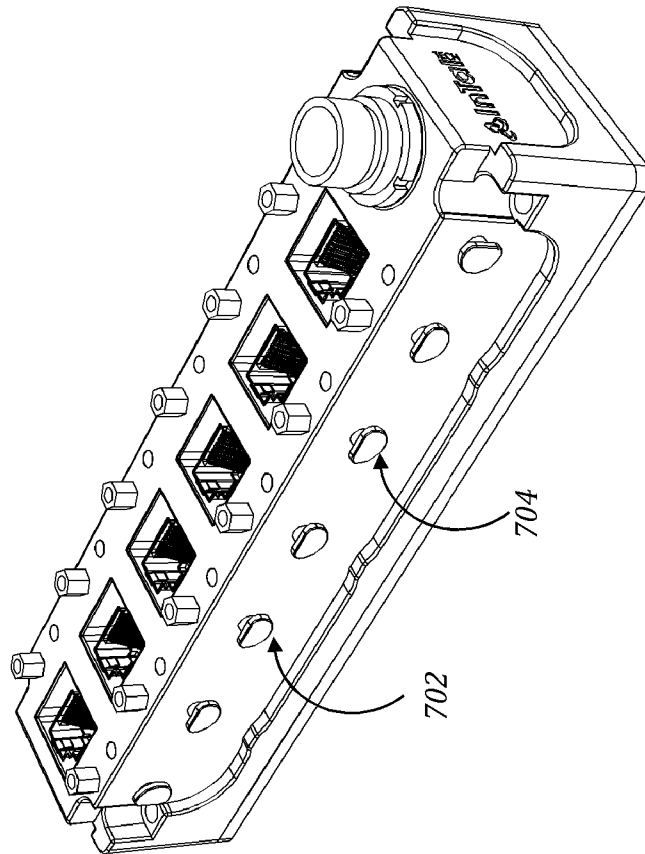

Fig. 7

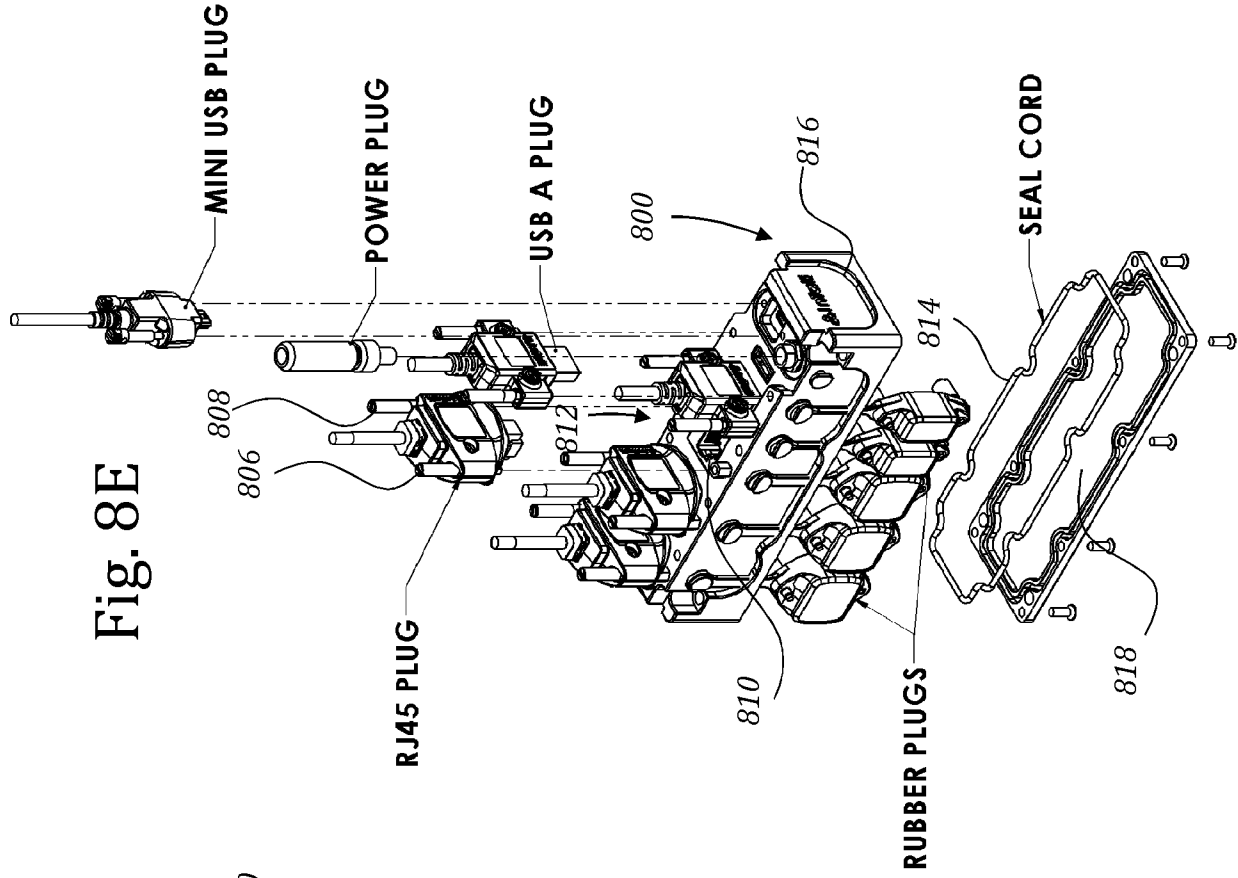

Fig. 8E

Fig. 8B

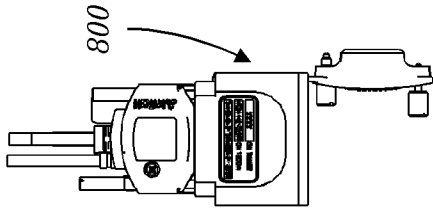
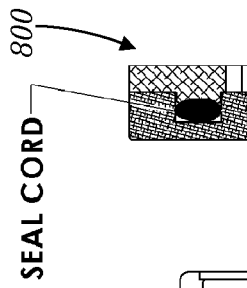
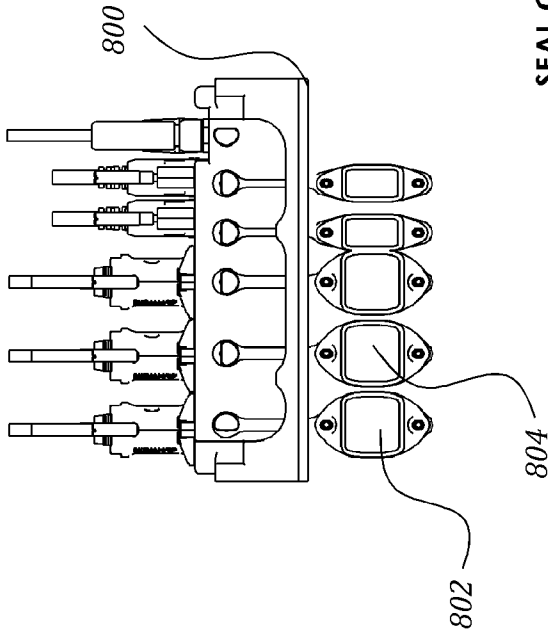

Fig. 8A



SECTION B-B
SCALE 3:1

Fig. 8D

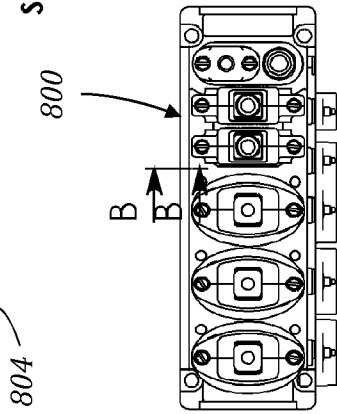

Fig. 8C