

:

(54)

(42) ,

(46)

(76)

1

quick connector) (quick connect coupling)가 (q
 가 가 가 (q
 (stem) 가 (barb)
 " 가 가
 Design)" 1996 8 6 (Quick Connector Housing With Elongated Barb
 5,542,712

가 가

12

2

,가

가

가

가

가

가

가

가

가

.O 가
(hoop strength)

(weeping)

1

2

2

1

2

1

2

2

, 2 . 가 2

1

2 1

3 1

4

5

1 4 , (44) , (46) (42)
 가 (40)

2 , (42) , (50)가 1 (52) 2 (54)
 (48)

(44) (40) 1 1 (52) (50)
 (60) (58) (upset bead)(56) (48)
 가 (44) 1 2 O (62, 64) (50)
 (48) , O (66) 2 (68)
 (70) , (44) (58)
 (50) (42)
 (44) (60) (42)

(48) (50) (72) (44) (58) (slip
 - fit)

(77) (48) , 2
 (76) (nose)(80) (76) 2 (54)
 (79)

- (46) (82) (81) (81)

(82)

가 12 - (46) " NYCLAD"

(46) (82) (81) (48) (80)

2 (81) (46) (48) (46)

(48) 가 (79)

3 4 (46) (48)

4 (46) 2 (54) (48)

6)가 (80) (46) (46)가 (48) (9)

(80)

(76) (72) (79) (48) (76) (78) (78)

(54) (78) (50) 2 (54) (46) (76) 2

(46) (48) (76)

(46)가 (48) 가 (46)

(48) 가 (46)

(96)가 (46) (48) 가 (46)

(76) (98) 가

4 (46) (82) (100) (79)

(104)

0,248 (Mueller) 2,933,428 (Minoshima) 3,98

(Jansman) 5,152,855

(82) (48)

5 (48) , 2 (54)
 (79') , 2
 (76) 가 1 (84) (80) 2
 (54) 가 2 (86) (86) .
 , 2 (86) (46) (96)
 , (46) (82) (48)

2) (46) (48)가 (46) (8
 가 1 (84) (48) 1 2 (84, 86)
 (46) (82) (48) 360°

(48) 2 가 (flash trap) 가
 " (Spin Welded Fluid Connector)"
 6,199,916

가
 360°

(57)

1.

1 , 2

2.

1 , 2

3.

1 , 2 ,

4.

1 , 가

5.

2 , 1 ,

6.

5 , 2

7.

5 , 2

8.

5 , 가

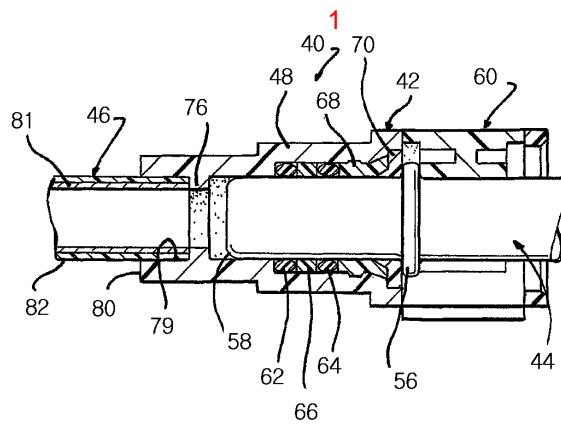

2

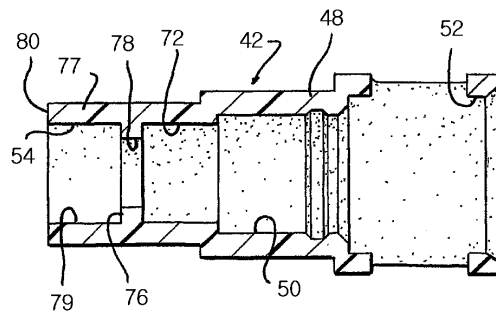

3

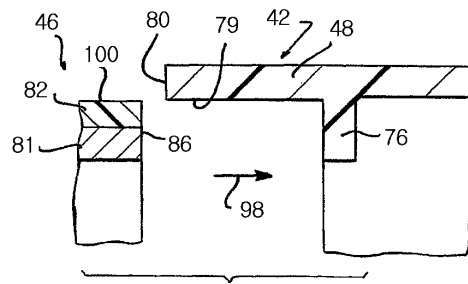

4

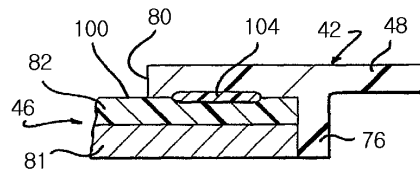

5

