

March 31, 1964

A. J. DUBNICK  
TAPE DISPENSER

3,127,078

Filed Aug. 15, 1961

2 Sheets-Sheet 1

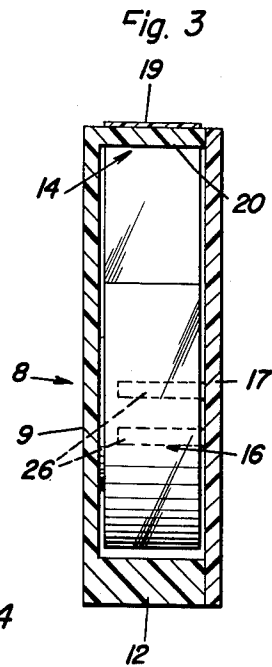
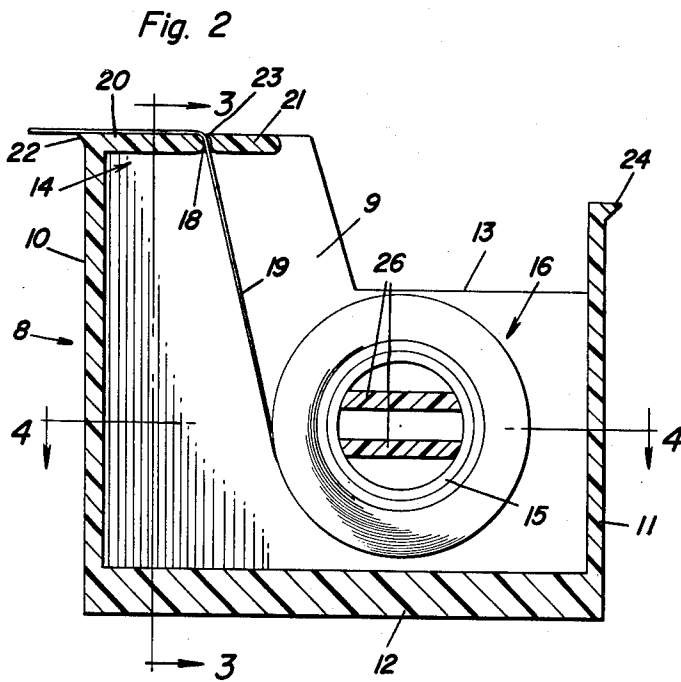
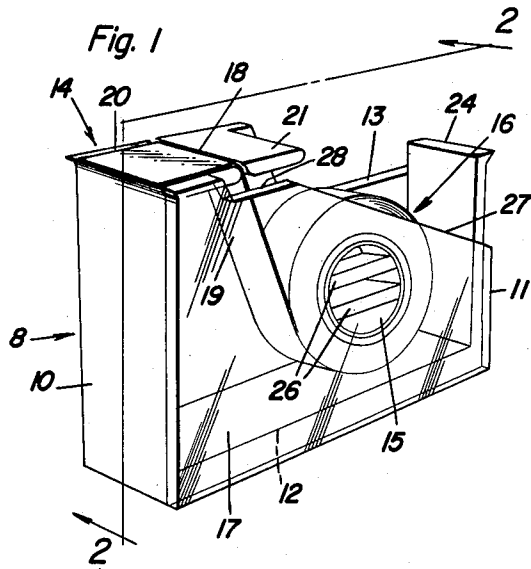

Arnold J. Dubnick  
INVENTOR.

BY *Alvanee A. O'Brien*  
*and Harvey B. Jacobson*  
Attorneys

March 31, 1964

A. J. DUBNICK

3,127,078

TAPE DISPENSER

Filed Aug. 15, 1961

2 Sheets-Sheet 2

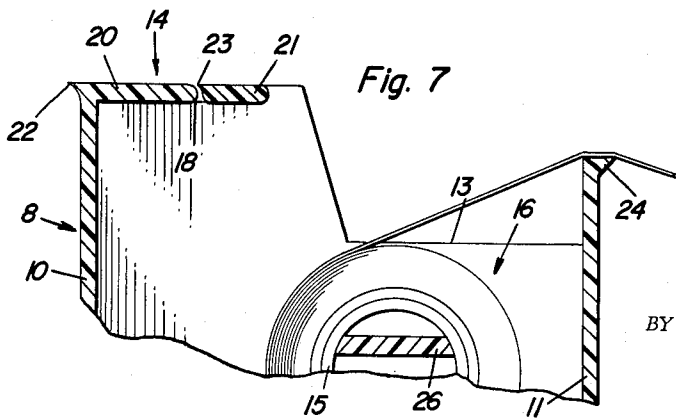
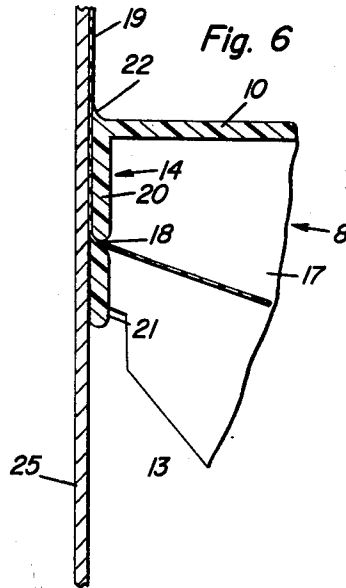
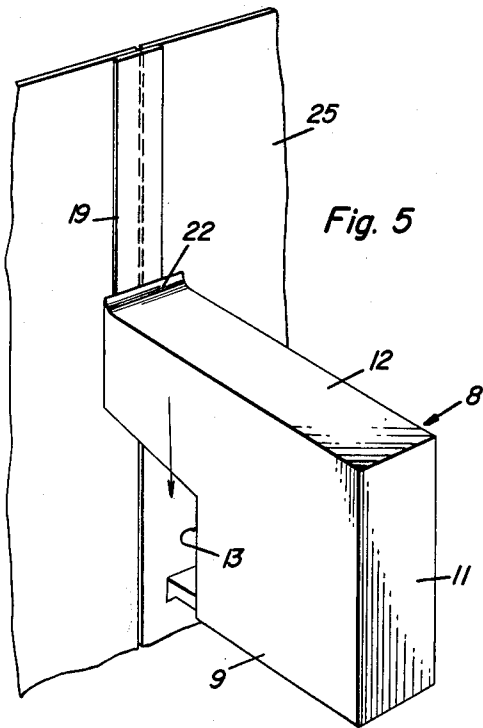
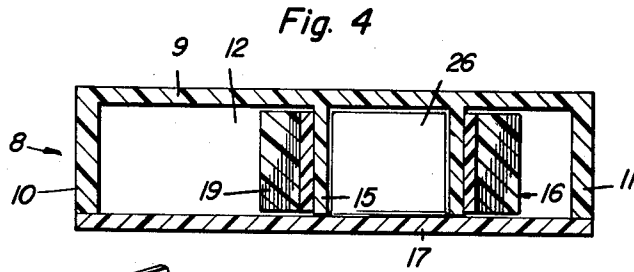

Arnold J. Dubnick  
INVENTOR.

BY *Alvanice A. Brown*  
*and Harvey B. Jackson*  
Attorneys

1

2

3,127,078

TAPE DISPENSER

Arnold J. Dubnick, 6921 21st St., Sacramento, Calif.

Filed Aug. 15, 1961, Ser. No. 131,659

2 Claims. (Cl. 225-33)

This invention relates to new and useful improvements in dispensers for tape particularly, although not necessarily, of the adhesive variety and has for its primary object to provide, in a manner hereinafter set forth, a device of this character wherein the tape may be drawn off by hand in the usual manner or, if desired, applied directly to the work without touching said tape with the fingers.

Another very important object of the present invention is to provide a dispenser of the aforementioned character which is adapted to be held stationary in or on a suitable support such as a stand in any desired manner whereby an article to be taped such, for example, as a vial, may be applied directly to the tape which is then cut off, thus again permitting the operation to be completed without touching the tape with the fingers.

Still another important object of the invention is to provide a tape dispenser and applicator of the character described which is adapted to accommodate rolls of tape of various widths and diameters within a given range.

Still another important object of the invention is to provide a tape dispenser and applicator of the character set forth comprising unique means for neatly severing the tape at the desired point and retaining the free end portion thereof to facilitate the start of the next operation.

Other objects of the invention are to provide a tape dispenser and applicator which will be comparatively simple in construction, strong, durable, compact, of light weight, attractive in appearance and which may be manufactured at low cost.

These together with other objects and advantages which will become subsequently apparent reside in the details of construction and operation as more fully hereinafter described and claimed, reference being had to the accompanying drawings forming a part hereof, wherein like numerals refer to like parts throughout, and in which:

FIGURE 1 is a perspective view of a tape dispenser and applicator constructed in accordance with the present invention;

FIGURE 2 is a vertical sectional view on an enlarged scale, taken substantially on the line 2-2 of FIGURE 1;

FIGURE 3 is a cross-sectional view, taken substantially on the line 3-3 of FIGURE 2;

FIGURE 4 is a view in horizontal section, taken substantially on the line 4-4 of FIGURE 2;

FIGURE 5 is a perspective view, showing the device in use as an applicator;

FIGURE 6 is a fragmentary view in vertical section, showing the device in use as an applicator; and

FIGURE 7 is a fragmentary view in vertical section through the upper portion of the dispenser, showing the position of the tape when it is being dispensed by hand.

Referring now to the drawing in detail, it will be seen that the embodiment of the invention which has been illustrated comprises a substantially flat, vertical open-top case or housing of suitable material, preferably a transparent plastic, which is designated generally by reference numeral 8. The case 8 includes a side wall 9 having formed integrally therewith a front wall 10 and a relatively low or short rear wall 11. In the embodiment shown, the case 8 further comprises an integral bottom 12 which is comparatively thick for added weight.

As shown to advantage in FIGURE 2 of the drawing, the upper rear portion of the side wall 9 is cut away or

recessed as indicated at 13. Formed integrally with the upper front portion of the side wall 9 of the case 8 is a flat top portion or platform 14. It will be noted that the front portion of the platform 14 is also integral with the front wall 10 of the case 8. Also formed integrally with the side wall 9 of the case 8 is a cylindrical spool or spindle 15 for rotatably receiving thereon a conventional roll 16 of cellophane or other adhesive tape. The side of the case 8 which is opposite the side wall 9 thereof comprises a removable side wall or plate 17 providing access to the spool or spindle 15 for loading the device.

The platform 14 includes a transverse slot 18 through which the tape from the roll 16, as indicated at 19, is threaded. The slot 18 divides the platform 14 into the front and rear sections 20 and 21, respectively. At its forward end the platform 14 terminates in a lip which projects forwardly beyond the wall 10 of the case 8 and is sharpened to provide a horizontal cutting edge 22. The front wall of the slot 18 is substantially convex or rounded, as shown, to facilitate the passage of the tape through said slot. The rear wall of the slot 18 is essentially bevelled and somewhat concave to provide a lip or the like 23 which overlies the front wall 18 and prevents the free end portion of the tape 19, when it is severed at 22, from withdrawing through the slot into the case 8. The top of the rear wall 11 of the case 8 is formed to provide a horizontal, rearwardly projecting cutting edge 24.

Formed integrally with the removable plate 17 is a pair of spaced tongues, arms or lugs 26 which are insertable in and engageable with the tubular spindle 15 for frictionally securing said plate in position on the case 8. The plate 17 includes a rearwardly inclined upper edge portion 27 and a recessed portion 28, the latter exposing one end of the slot 18 to facilitate threading the tape through said slot without removing said plate.

It is thought that the use or operation of the device will be readily apparent from a consideration of the foregoing. Briefly, to load the device the access plate 17 is removed to permit the roll 16 to be slipped on the spool or spindle 15, after which said plate is replaced. If the tape is to be dispensed by hand the case 8 is held in one hand and the tape 19 is pulled rearwardly over the rear wall 11 of said case and when the desired length has been unwound said tape is severed by the knife or cutting edge 24. The top edge portion 27 of the plate 17, being below the cutter 24, facilitates rearward threading of the tape in the manner described and its removal from said cutter. If on the other hand the tape is to be applied directly to the work, as indicated at 25, from the roll, said tape is threaded through the slot 18 in the platform 20. The device as seen in FIGURES 1 and 2 is then inverted and turned end for end (FIGURES 5 and 6) for engaging the platform 20 with the work 25 with the free end portion of the tape 19 therebetween. Then, while applying the correct pressure the case 8 is pulled downwardly or in any direction on the work for applying the tape in an obvious manner. While the device is preferably of a suitable plastic, the case 8 may also be of metal. As hereinbefore stated, the bottom 12 of the case 8 is relatively thick for added weight. It will be noted that, as the tape is viewed in FIGURE 2 of the drawing, the adhesive is on the upper or outer side thereof. The spool or spindle 15 and the roll 16 thereon are located rearwardly of the platform 14 and the slot 18 therein to facilitate the movement of the tape 19 as it leaves said roll. Movement of the tape 19 is also facilitated by the shape of the walls of the slot 18. The lip 23 of the platform 14 retains the exposed end portion of the tape. The open portion 13 of the case 8 permits the roll 16 to be thumbed, if desired.

3

It is believed that the many advantages of a tape dispenser constructed in accordance with the present invention will be readily understood and although a preferred embodiment of the device, is as illustrated and described, it is to be understood that changes in the details of construction and in the combination and arrangement of parts may be resorted to which will fall within the scope of the invention as claimed. For example, suitable means may be provided on or adjacent the platform 14 for wetting tape of the type requiring moisture.

What is claimed as new is as follows:

1. A tape dispenser comprising an upstanding housing including a pair of upstanding opposite side walls, journaling means in said housing adapted to journal a roll of tape for rotation about an axis extending between said side walls, means at the upper portion of the front end of said housing defining a generally horizontal surface extending transversely of said housing and including a front terminal end portion projecting forwardly beyond the front end of the adjacent end of said housing and defining a cutting edge extending transversely of said housing, the rear end of said surface curving downwardly toward said journaling means, abutment means extending transversely of said housing, and spaced slightly rearwardly of and in general horizontal alignment with said horizontal surface and including a forward rearwardly and downwardly beveled surface including an upper portion vertically overlying the rear-most extremity of the downwardly and curving rear end of said horizontal surface in spaced relation thereto, the space between said horizontal surface and said abutment means defining a slot through which tape to be dispensed may be threaded.

2. A tape dispenser comprising an upstanding housing including a pair of upstanding opposite side walls, journaling means in said housing adapted to journal a roll of tape for rotation about an axis extending between said side walls, means at the upper portion of the front end of said housing defining a generally horizontal surface extending transversely of said housing and including a front terminal end portion projecting forwardly beyond the front end of the adjacent portion of said housing and

4

defining a cutting edge extending transversely of said housing, the rear end of said surface extending downwardly toward said journaling means, abutment means extending transversely of said housing and spaced slightly rearwardly of and in general horizontal alignment with said horizontal surface, the space between said horizontal surface and said abutment means defining a slot through which tape to be dispensed may be threaded, means at an upper portion of the rear end of the housing defining a generally horizontal surface extending transversely of said housing and including a rear terminal end portion projecting rearwardly beyond the rear terminal end of the adjacent portion of said housing and defining a cutting edge extending transversely of said housing, the upper portion of said housing being open between the last-mentioned horizontal surface and said abutment means, the first-mentioned horizontal surface interconnecting the upper ends of the adjacent ends of said side walls and said abutment means extending laterally outwardly from one of said side walls toward the other side wall, the portion of said other side wall disposed rearwardly of the forward end of said slot, the upper end of the portion of said other side wall disposed rearwardly of the forward end of said slot terminating a spaced distance below said abutment means and the lower end of said slot whereby an extended end of a length of tape projecting upwardly between the rear horizontal surface and the abutment means may be threaded laterally past the free end of said abutment means so as to be disposed in said slot.

References Cited in the file of this patent

UNITED STATES PATENTS

1,026,778	Toles -----	May 21, 1912
2,118,791	Hines -----	May 24, 1938
2,295,679	Montbach -----	Sept. 15, 1942
2,309,396	Jackson -----	Jan. 26, 1943
2,414,333	Schieman -----	Jan. 14, 1947
2,476,593	Gerbing -----	July 19, 1949
2,586,346	King -----	Feb. 19, 1952
3,016,174	Perkins -----	Jan. 9, 1962
3,031,117	Maccaferri -----	Apr. 24, 1962