



(11) **EP 1 529 708 B1**

(12) **EUROPEAN PATENT SPECIFICATION**

(45) Date of publication and mention of the grant of the patent:  
**16.07.2008 Bulletin 2008/29**

(51) Int Cl.:  
**B61D 25/00<sup>(2006.01)</sup> E05B 65/10<sup>(2006.01)</sup>**

(21) Application number: **04425608.9**

(22) Date of filing: **04.08.2004**

(54) **Window with an opening of the tiltable type, and with full tipping and removal in emergency situations, for railway carriages**

Kippfenster für Eisenbahnwagen mit vollständigem Umkippen und Entfernung in Notsituationen

Fenêtre basculante pour véhicules ferroviaires avec basculement complet et enlèvement en cas de situations d'urgence

(84) Designated Contracting States:  
**AT BE BG CH CY CZ DE DK EE ES FI FR GB GR HU IE IT LI LU MC NL PL PT RO SE SI SK TR**

(30) Priority: **05.11.2003 IT FI20030285**

(43) Date of publication of application:  
**11.05.2005 Bulletin 2005/19**

(73) Proprietor: **Ciesse S.P.A.**  
**50012 Bagno a Ripoli (FI) (IT)**

(72) Inventor: **Pinzauti, Francesco**  
**50065 Pontassieve (Firenze) (IT)**

(74) Representative: **Bardini, Marco Luigi et al**  
**c/o Società Italiana Brevetti S.p.A.**  
**Corso dei Tintori, 25**  
**50122 Firenze (IT)**

(56) References cited:  
**US-A- 2 639 790 US-A- 4 313 280**  
**US-A1- 2003 107 221**

**EP 1 529 708 B1**

Note: Within nine months of the publication of the mention of the grant of the European patent in the European Patent Bulletin, any person may give notice to the European Patent Office of opposition to that patent, in accordance with the Implementing Regulations. Notice of opposition shall not be deemed to have been filed until the opposition fee has been paid. (Art. 99(1) European Patent Convention).

## Description

**[0001]** The present invention relates in general to fittings for rolling stock. More particularly the invention relates to a window with opening of the tiltable type for railway carriages, designed to be tipped up and also, if necessary, removed in the event of an emergency.

**[0002]** It is known that the windows in railway carriages fitted with an air-conditioning system cannot be opened. However there is the possibility in some of them for staff to release the closure device in the case wherein the air-conditioning system does not work. The windows which can be released are usually of the tiltable type and therefore ensure limited opening, sufficient for allowing air to circulate.

**[0003]** The opening which can be obtained with these releasable windows is not however sufficient for emergency situations in which apertures have to be formed for rapid evacuation of passengers. In these cases there is the possibility of breaking the glass of the windows with special emergency hammers available in each carriage. This operation is hazardous and may jeopardise the safety of passengers due to the risks of injury which it entails, risks which increase in emergency conditions, and also causes damage to the railway carriage which requires costly and lengthy maintenance work.

**[0004]** US 2003/0107221 A1 discloses a window according to the preamble of claim 1.

**[0005]** The object of the present invention is to avoid the disadvantages described above by providing a window for railway carriages with opening of the tiltable type and which, if required, can be tipped up completely and possibly removed to provide an adequate aperture for evacuating passengers without the need to smash any window.

**[0006]** This object is achieved with a window according to the subject-matter of claim 1; such a window with a hinge opening for railway carriages whose characteristic feature consists in that the tiltable portion is hinged to the surround of the window by means of a pair of aligned and axially sliding pins so as to define a first position wherein they are engaged in housings integral with the surround, and a second position wherein, following axial translation one towards the other, they are disengaged therefrom. The tiltable portion is also hinged, parallel to the pair of pins, to an intermediate cross member of the window integral with the surround, so that, when the pins are in the first position, the tiltable portion can only perform an angular movement of preset extent after the locking means have been disabled manually, whereas, when they are placed in the second position, the tiltable portion can rotate in relation to the cross member until it is fully tipped up, the locking means being disabled following lowering of the tiltable portion as a result of disengaging of the ends of the pins from the respective housings.

**[0007]** The features and advantages of the window with opening of the tiltable type for railway carriages according to the present invention will be made clearer from

the following description of embodiments thereof, given by way of a non-limiting example with reference to the accompanying drawings, wherein:

- 5 - Figure 1 is a front view from the inside of a first embodiment of a window for railway carriages according to the present invention;
- Figure 2 is a partial vertical section of the window of the invention along line II-II of Figure 1;
- 10 - Figure 3 is an enlarged section view of the crank mechanism for actuating the pair of pins around which tiltable rotation of the window takes place;
- Figure 4 is a partial section view of an end portion of the transverse structure of the window according to the invention;
- 15 - Figure 5 is a partial vertical section taken along line V-V of Figure 4;
- Figure 6 is a partial vertical section taken along line VI-VI of Figure 4;
- 20 - Figure 7 is a partial section view of an end position of the window like Figure 4, but with the pin in the second position;
- Figure 8 is a partial vertical section taken along line VIII-VIII of Figure 4;
- 25 - Figure 9 is a partial vertical section, the same as that of Figure 8, wherein however the tiltable portion of the window has been opened;
- Figure 10 is a partial vertical section taken along line X-X of Figure 4;
- 30 - Figure 11 is a partial vertical section similar to that of Figure 10, wherein the tiltable portion of the window is fully tipped up;
- Figures 12 and 13 are views equivalent to Figures 2 and 3 of a different embodiment of the device for actuating sliding of the pins for rotation of the mobile part of the window, Figure 13 being a section taken along line XIII-XIII of Figure 12;
- 35 - Figure 14 is a section view taken along line XIV-XIV of Figure 15 of another embodiment relating to the device for controlling rotation of the mobile part of the window in the closure position;
- 40 - Figure 15 is a section taken along line XV-XV of the device illustrated in Figure 14;
- 45 - Figure 16 is a section view taken along line XVI-XVI of Figure 17 of the same embodiment of the device illustrated in Figures 14 and 15, but in the position which allows the mobile part of the window to be tipped up;
- 50 - Figure 17 is a section taken along line XVII-XVII of the device illustrated in Figure 16;
- Figures 18 and 19 illustrate the window according to the invention, in the version shown in Figures 14 and 17, in a tilted position and initial tipping respectively.

55 **[0008]** Referring to Figure 1, 1 denotes generically a window of a railway carriage, which window is formed by a fixed window portion 2 and by a tiltable window portion 3 normally locked in a closed position and which can be

released by staff on duty using the locks 4 situated in the upper part thereof by means of a special key for allowing limited opening of the window in the case wherein the air-conditioning of the carriage is not in operation.

**[0009]** The structure of the window is, as a whole, of the conventional type and comprises a surround denoted by 5 and formed by an external part 5a for resting on the window-space formed in the side wall of the carriage, and an internal part 5b projecting internally from the outside one and acting as a support for a glass 7 of the fixed portion 2 of the window and as an abutment for the tiltable portion 3. The latter is in turn formed by a pane of glass 8 bordered around the perimeter by a frame 9 hinged to a transverse structure 10, whereto the lower pane of glass 7 is also attached.

**[0010]** Referring to Figure 2, the transverse structure 10 is formed by a cross member or section bar 11 with a substantially H shape for bordering below a groove tightly housing the upper edge of the glass 7. The lower edge 9a of the frame 9, wherein the corresponding lower edge of the glass 8 is tightly housed, is engaged on a pair of pins 12a and 12b, coaxial and aligned one with the other and around which the frame 9 can rotate, allowing tiltable opening of the window. As also shown in Figures 3 and 4, the two pins 12a,b are slidingly engaged in bushings 13 integral with the lower edge 9a of the frame 9 and, at the ends of the cross member 11, in respective housings 14 (only one is shown in the drawings) formed in support blocks 15 attached by means of screws 16 to the inner part 11a of the H-shaped cross member 11.

**[0011]** In order to actuate axial sliding of the pins 12a, b which move towards or apart from each other, an actuation device is provided, more particularly a crank mechanism with manual actuation integral with a profile 23 and connected to the two opposite ends of the pins 12a,b. More specifically, the free ends of the two pins 12a and 12b are connected to a disk 19 by means of respective connecting rods 17 and 18, which are connected eccentrically and at diametrically opposite parts to said disk 19. Disk 19 is integral with a stem 20 pivotally supported by the profile 23 and emerging frontally therefrom with one of its heads 20a set up for actuation by means of a special key.

**[0012]** By rotating the stem 20 and the disk 19 integral therewith, it is possible to transmit a sliding movement to the two pins 12a and 12b, bringing them from a first position, corresponding to what is illustrated in Figures 3 and 4, wherein the pins 12a and 12b are engaged in the respective support blocks 15, to a second position, illustrated in Figures 7 and 10, wherein the ends of the pins 12a,b are fully disengaged therefrom. Rotation of the disk 19 is contrasted elastically by a flat spring 21 which pushes against a perimeter flattened part 19a of the disk 19. The flattened part 19a is positioned at the spring 21 when the pins 12a,b are in the aforesaid first position, which is the normal position of said pins, preventing accidental or unauthorised rotations of the disk

19.

**[0013]** Referring to Figures 4-7, the cross member 11 is connected by means of a hinge 22 to the profile 23, extending inside the same cross member 11. At the ends of the profile 23 two shoulders 24 are attached (only one can be seen in the drawings), wherein a slot 25 is formed at the housings 14 of the blocks 15 whereto the shoulders 24 are adjacent. Moreover the profile 23 has at least two intermediate apertures 26 (only one can be seen in the drawings) with the function which is to be described here-in below.

**[0014]** A block 27 is attached to the pin 12a (the same applies for the pin 12b), wherefrom an appendage 28 extends (see also Figure 8), abutting on a ridge 23a of the profile 23. This condition occurs when the pins 12a, b are in their first position, i.e. with their ends engaged in the housings 14 of the blocks 15. The appendage 28 also constitutes an abutment element for the edge 9a of the frame 9 when the latter and the glass 8 attached thereto are rotated around the pins 12a,b. As shown in Figure 9, the lower edge 9a of the frame 9 abuts on the appendage 28 on the opposite side to the ridge 23a of the profile 23, effectively limiting rotation of the frame 9 to a preset angle (denoted by  $\alpha$ ).

**[0015]** As shown in Figures 7 and 10, by placing the pins 12a, 12b in the second position, i.e. that in which the respective ends of the pins are disengaged from the housings 14 of the blocks 15 and are positioned at the slot 25 formed in each of the shoulders 24, the appendage 28 of the block 27 is positioned at the aperture 26 of the profile 23.

**[0016]** Since the slot 25 has a length longer than the diameter of the housing 14 and extends towards the profile 23, once the end of the pins 12a,b has disengaged from the relevant housing 14, said end goes to the base of the slot 25, causing lowering of the pins 12a,b and of the frame 9 integral thereto, while the appendage 28 is positioned in the aperture 26. The frame 9 is lowered automatically, once the ends of the pins 12a,b are disengaged from the housings 14, due to its own weight which automatically releases the frame from the locking devices denoted by 4 and situated in the upper part of the window.

**[0017]** In the condition described above the frame 9 is free to rotate around the hinge 22, adopting a fully tipped condition illustrated in Figure 11, no longer being attached to the support blocks 15 by means of the ends of the pins 12a,b.

**[0018]** If, in addition to tipping, the frame 9 also has to be removed from the window 1, a third position of the pins 12a,b can be provided wherein they can also be withdrawn from the slots 25. This can be obtained by defining two different extents of rotation of the disk 19, corresponding to two different extents of sliding of the pins 12a,b. More particularly, with a first rotation, the pins 12a,b can be slid until they are disengaged from the housings 14 of the blocks 15 and with a second subsequent rotation, to be performed if the tiltable portion also has

to be removed, the ends of the pins 12a,b can be disengaged from the slots 25 of the shoulders 24. Another way of fully freeing the frame 9 also from the profile 23, pivotally connected to the cross member 11, is to make the slot 25 in a form which is open at the top, so that tipping of the frame 9 also causes simultaneous sliding of the ends of the pins 12a,b along the respective slots 25 causing them to exit therefrom at the end of the tipping movement. This solution is not illustrated in detail, in that it is in itself obvious in light of the drawings.

**[0019]** Seals 29 and 30 are placed between the lower edge 9a of the frame 9 and the cross member 11 on one side and the profile 23 on the other.

**[0020]** Figures 12 and 13 illustrate a different embodiment of the device for actuating axial sliding of the pins 12a and 12b around which the tiltable part 3 rotates. In these drawings the same components present in the previous drawings have the same reference numeral. In this embodiment the disk 19, where to the pins 12a,b are connected via the connecting rods 17 and 18, is integral with a lever 32, which can also be actuated by the user, if necessary, without having to wait for help by the staff in charge, provided with the special key for turning the disk 19. An elastic plate 31 with an overturned V portion which engages in the disk 19 prevents free rotation of the same disk and hence axial sliding of the pins 12a,b, maintaining the tiltable part 3 in a closed position. On the other hand, by overcoming the elastic reaction of the plate 31, it is possible to disengage it from the disk 19 to allow its rotation and hence axial sliding of the two pins 12a,b.

**[0021]** In the embodiment of the invention shown in Figures 1-11, the possibility of rotation around the pins 12a,b of the tiltable portion 3 is controlled by the abutting of the lower edge 9a of its frame 9 on the appendage 28 of the block 27 integral with the pin 12a and, correspondingly, the pin 12b. In a different embodiment, illustrated in Figures 14 and 15, a plate 34 with a projection 33 is attached laterally to the frame 9, holding the glass 8 of the window. The block 15, in which the housing 14 for the end of the pin 12a (12b) is formed, extends inside the surround 5 up to the height of the projection 33 at which it is shaped with an angled edge 15a extending towards said projection 33. Figure 14 illustrates the relative position of the angled edge 15a and of the projection 33 when the tiltable portion 3 is closed. Figure 18 illustrates the relative position of the two components when the tiltable portion 3 is open. In this condition the projection 33 abuts on the angled edge 15a, locking the tiltable portion in an open position with the preset slant.

**[0022]** When the pins 12a, 12b are disengaged from the corresponding housings 14 of the block 15, following actuation of the disk 19 (by means of a special key or the lever 32), the tiltable portion 3 lowers as shown in Figures 16 and 17 so that the projection 33 also lowers, bringing itself below the angled edge 15a of the block 15. In this case rotation of the tiltable portion 3 around the pins 12a, b is no longer limited by the abutting between the projection 33 and the angular edge 15a and can continue as

shown in Figure 19, until the tiltable portion 3 is fully tipped. It will be noted that in this solution removal of the tiltable portion 3 once the position of full tipping has been achieved is not provided. Thanks to the distance between the projection 33 and the axis of rotation of the pins 12a, b, the tensile stress resistance of the tiltable portion 3 in an open condition is improved.

**[0023]** From the foregoing it is clear that the window for railway carriages according to the present invention achieves in full the object set. It can in fact function as a normal window for air-conditioned carriages, since it can be locked in a closure position, and can be partially opened, in the case of non-functioning of the air-conditioning system, by actuating the locking devices 4 and rotating the tiltable portion 3 of the window 1 around the pins 12a,b. The window according to the invention also allows full tipping of the tiltable portion 3 in case emergency conditions should occur simply by actuating with a special key the stem head 20a placed centrally in relation to the window on the cross member 11, or by means of the lever 32, to disengage the ends of the pins 12a,b from the respective housings integral with the fixed structure. If considered necessary, it is also possible to provide for complete removal of the tiltable portion 3 of the window. The invention therefore allows emergency apertures through the windows to be provided without the need to smash the glass.

**[0024]** Variations and/or modifications may be made to the window for railway vehicles according to the present invention without thereby departing from the scope of the invention as set forth in the appended claims.

## Claims

1. Window with an opening of the tiltable type for railway carriages comprising a tiltable portion (3) hinged to a surround (5) thereof and means (4) for locking said tiltable portion in a closed condition, **characterised in that** said tiltable portion is hinged to said surround by means of a pair of aligned and axially sliding pins (12a,b) so as to define a first position, wherein they are engaged in housings (14) integral with said surround, and a second position wherein, following axial translation towards one another, they are disengaged therefrom, said tiltable portion being also hinged, parallel to said pair of pins, to an intermediate cross member (11) of said window integral with said surround (5), so that, when said pins are in said first position, said tiltable portion can only perform an angular movement of preset extent after manual disabling of said locking means, whereas, when they are placed in said second position, said tiltable portion rotates in relation to said cross member (11) until it is fully tipped, said locking means being disabled following lowering of said tiltable portion as a result of disengaging of the ends of the pins (12a,b) from the respective housings (14).

2. Window according to claim 1, wherein said pair of pins is connected slidingly to the lower edge (9a) of said tiltable portion (3) and is linked to a device (17,18,19,32) for actuating their axial sliding movement to and from each other.
3. Window according to claim 2, wherein said device comprises a manually actuated crank mechanism (17, 18, 19, 32) integral with a profile (23) hinged to said cross member (11) and connected to the two opposite ends of said pins (12a,b).
4. Window according to claim 3, wherein said crank mechanism comprises a disc-shaped body (19) integral with a stem (20) supported by a profile (23) hinged to said cross member (11), connected eccentrically to two connecting rods (17,18) in a substantially diametrical position, said connecting rods being in turn connected to the opposite ends of said pins (12a,b), said crank mechanism being accessible via a head of said stem for actuation by means of a special key.
5. Window according to claim 3, wherein said crank mechanism comprises a disc-shaped body (19) integral with a stem (20) supported by a profile (23) hinged to said cross member (11), connected eccentrically to two connecting rods (17,18) in a substantially diametric position, said connecting rods being in turn connected to the opposite ends of said pins (12a,b), said stem being integral with a lever (32) accessible for its actuation.
6. Window according to claims 4 or 5, wherein the rotation of said disc-shaped body (19) is opposed elastically.
7. Window according to any one of the previous claims, wherein the other ends of said pins are rotatably and slidingly connected to supports (15) integral with said cross member (11).
8. Window according to any one of the previous claims, wherein said cross member (11) is formed by a section bar with a substantially H shape, wherein a profile (23) is positioned, hinged thereto and integral with said pair of pins (12a,b) through a pair of end shoulders (24) having respective slots (25) in which in said pair of pins is engaged.
9. Window according to claims 7 or 8, wherein said supports (15), integral with said section bar (11), have respective housings (14) for the ends of said pins (12a,b) aligned with said slots (25) of said shoulders (24), the length of said slots being greater than the diameter of said housings, said slots extending towards said profile.
10. Window according to claim 9, wherein said profile has a longitudinal ridge (23a) and at least two apertures (26) which break up said ridge, said pins holding respective abutment elements (28) abutting on said ridge when said pins are in said first position, the lower edge (9a) of said tiltable portion abutting on said abutment element (28), on the side opposite said ridge (23a), after a limited angular movement of said tiltable portion, said abutment elements being engageable in said apertures when said pins are in said second position and are engaged in the slots of said shoulders, so that said tiltable portion can drive said profile (23) to rotate by means of said shoulders (24) around said section bar (11) until it is fully tipped.
11. Window according to any one of the previous claims, wherein the slots (24) of said shoulders are closed and said pair of pins is designed to be placed in a third position wherein the ends of said pins are disengaged also from said slots to allow removal of the tiltable portion.
12. Window according to any one of claims 1 to 10, wherein said slots (24) are open above so that, once said tiltable portion has been fully tipped, the ends of said pair of pins, in said second position, can be disengaged from said slots for removal of said tiltable portion.
13. Window according to any one of claims 1 to 9, wherein said tiltable portion (3) comprises a frame (9), at the sides whereof a projection (33) is formed, said supports (15) extending as far as the height of said projection (33) and having there an angled edge (15a), said projection abutting on said angled edge when said pins (12a,b) are engaged in the respective housings (14) of said supports (15), so as to limit rotation of said tiltable portion and allowing instead rotation of said tiltable portion until it is tipped when the latter is lowered as a result of disengaging of said pins (12a,b) from the respective housings (14).

#### Patentansprüche

1. Kippfenster für Eisenbahnwagen, enthaltend ein Kippteil (3), das an einer Einfassung (5) davon angelenkt ist, und Einrichtungen (4) zum Verriegeln des Kippteils in einem geschlossenen Zustand, **dadurch gekennzeichnet, dass** das Kippteil an der Einfassung mittels eines Paares von ausgerichteten und axial verschiebbaren Stiften (12a, b) angelenkt ist, um eine erste Position, in der sie in Gehäusen (14) in Eingriff sind, die integral mit der Einfassung sind, und eine zweite Position zu definieren, in der sie auf eine axiale Verschiebung aufeinander zu davon außer Eingriff sind, welches Kippteil auch parallel zu dem Paar von Stiften an einem zwischenliegenden Kreuzungsglied (11) des Fensters integral mit der

- Einfassung (5) angelenkt ist, so dass, wenn die Stifte in der ersten Position sind, das Kippteil nur eine Winkelbewegung eines vorgegebenen Ausmaßes nach dem manuellen Entriegeln der Verriegelungseinrichtungen ausführen kann, wohingegen, wenn sie in der zweiten Position sind, sich das Kippteil bezüglich des Kreuzungsgliedes (11) dreht, bis es vollständig umgekippt ist, welche Verriegelungseinrichtungen nachfolgend auf das Absenken des Kippteils als ein Ergebnis des außer Eingriff Bringens der Enden der Stifte (12a, b) aus den entsprechenden Gehäusen (14) entriegelt sind.
2. Fenster nach Anspruch 1, wobei das Paar von Stiften verschiebbar mit dem unteren Rand (9a) des Kippteils (3) verbunden ist und an eine Vorrichtung (17, 18, 19, 32) zum Betätigen ihrer axialen Verschiebungsbewegung zu und von einander gekoppelt ist.
  3. Fenster nach Anspruch 2, wobei die Vorrichtung einen manuell betätigten Kurbelmechanismus (17, 18, 19, 32) enthält, der mit einem Profil (23) integral ist, das an dem Kreuzungsglied (11) angelenkt und mit den zwei entgegengesetzten Enden der Stifte (12a, b) verbunden ist.
  4. Fenster nach Anspruch 3, wobei der Kurbelmechanismus einen mit einem Schaft (20), der von einem Profil (23) gestützt wird, das an dem Kreuzungsglied (11) angelenkt ist, integralen scheibenförmigen Körper (19) enthält, der exzentrisch mit zwei Verbindungsstäben (17, 18) in einer im wesentlichen diametralen Position verbunden ist, welche Verbindungsstäbe wiederum mit den entgegengesetzten Enden der Stifte (12a, b) verbunden sind, welcher Kurbelmechanismus über einen Kopf des Schaftes zum Betätigen mittels eines speziellen Schlüssels zugänglich ist.
  5. Fenster nach Anspruch 3, wobei der Kurbelmechanismus einen mit einem Schaft (20), der von einem Profil (23) gestützt wird, das an dem Kreuzungsglied (11) angelenkt ist, integralen scheibenförmigen Körper (19) enthält, der exzentrisch mit zwei Verbindungsstäben (17, 18) in einer im wesentlichen diametrischen Position verbunden ist, welche Verbindungsstäbe wiederum mit den entgegengesetzten Enden der Stifte (12a, b) verbunden sind, welcher Schaft integral mit einem Hebel (32) ist, der zu seiner Betätigung zugänglich ist.
  6. Fenster nach Anspruch 4 oder 5, wobei der Drehung des scheibenförmigen Körpers (19) elastisch entgegen gewirkt wird.
  7. Fenster nach einem der vorhergehenden Ansprüche, wobei die anderen Ende der Stifte drehbar und verschiebbar mit Haltern (15) verbunden sind, die integral mit dem Kreuzungsglied (11) sind.
  8. Fenster nach einem der vorhergehenden Ansprüche, wobei das Kreuzungsglied (11) durch einen Profilstab mit einer im wesentlichen H-Form gebildet ist, worin ein Profil (23) angeordnet ist, das daran angelenkt und integral mit dem Paar von Stiften (12a, b) durch ein Paar von Endschultern (24) ist, die entsprechende Schlitze (25) haben, in welchen das Paar von Stiften in Eingriff ist.
  9. Fenster nach Anspruch 7 oder 8, wobei die Halter (15), die integral mit dem Profilstab (11) sind, entsprechende Gehäuse (14) für die Enden der Stifte (12a, b) in Ausrichtung mit den Schlitzen (25) der Schultern (24) haben, wobei die Länge der Schlitze größer als der Durchmesser der Gehäuse ist, welche Schlitze zu dem Profil hin verlaufen.
  10. Fenster nach Anspruch 9, wobei das Profil eine Längsrippe (23a) und wenigstens zwei Öffnungen (26) hat, die die Rippe unterbrechen, welche Stifte entsprechende Anlageelemente (28) halten, die an der Rippe anliegen, wenn die Stifte in der ersten Position sind, wobei der untere Rand (9a) des Kippteils an dem Anlageelement (28) auf der Seite entgegengesetzt der Rippe (23a) nach einer beschränkten Winkelbewegung des Kippteils anliegt, welche Anlageelemente in den Öffnungen in Eingriff bringbar sind, wenn die Stifte in der zweiten Position sind und in den Schlitzen der Schultern in Eingriff sind, so dass das Kippteil das Profil (23) antreiben kann, um mittels der Schultern (24) um den Profilstab (11) zu rotieren, bis es vollständig umgekippt ist.
  11. Fenster nach einem der vorhergehenden Ansprüche, wobei die Schlitze (24) der Schultern geschlossen sind und das Paar von Stiften gestaltet ist, um in einer dritten Position angeordnet zu werden, in der die Enden der Stifte auch aus den Schlitzen außer Eingriff sind, um ein Entfernen des Kippteils zu gestatten.
  12. Fenster nach einem der Ansprüche 1 bis 10, wobei die Schlitze (24) oben offen sind, so dass, wenn das Kippteil einmal vollständig umgekippt ist, die Enden des Paares von Stiften in der zweiten Position aus den Schlitzen außer Eingriff gebracht werden können, um das Kippteil zu entfernen.
  13. Fenster nach einem der Ansprüche 1 bis 9, wobei das Kippteil (3) einen Rahmen (9) enthält, an dessen Seiten ein Vorsprung (33) ausgebildet ist, wobei die Halter (15) bis zur Höhe des Vorsprungs (33) verlaufen und dort einen abgewinkelten Rand (15a) haben, welcher Vorsprung an dem abgewinkelten Rand anliegt, wenn die Stifte (12a, b) in den jeweiligen Gehäusen (14) der Halter (15) in Eingriff sind,

um die Drehung des Kippteils zu beschränken und statt dessen eine Drehung des Kippteils zu gestatten, bis es umgekippt ist, wenn das Letztere abgesenkt ist, als ein Ergebnis, die Stifte (12a, b) aus den jeweiligen Gehäusen (14) außer Eingriff zu bringen.

## Revendications

1. Fenêtre avec une ouverture de type basculante pour véhicules ferroviaires comprenant une partie basculante (3) montée pivotante par rapport à un encadrement (5) et des moyens (4) pour verrouiller ladite partie basculante dans une position fermée, **caractérisée en ce que** ladite partie basculante est montée pivotante par rapport au dit encadrement au moyen d'une paire de goupilles alignées et coulissantes axialement (12a, b) de façon à définir une première position, dans laquelle elles sont engagées dans des logements (14) réalisés dans ledit encadrement, et une seconde position dans laquelle, après une translation axiale l'une vers l'autre, elles sont sorties des logements, ladite partie basculante étant aussi montée pivotante, parallèlement à ladite paire de goupilles, par rapport à un élément transversal intermédiaire (11) de ladite fenêtre solidaire du dit encadrement (5), de façon que, lorsque lesdites goupilles sont dans leur première position, ladite partie basculante peut seulement effectuer un mouvement angulaire d'une amplitude préétablie après que lesdits moyens de verrouillage aient été débloqués manuellement, et que, lorsqu'elles sont dans leur seconde position, ladite partie basculante pivote par rapport au dit élément transversal (11) jusqu'à ce qu'elle soit complètement basculée, lesdits moyens de verrouillage étant débloqués après que ladite partie basculante ait été abaissée à cause de la sortie des extrémités des goupilles (12a, b) hors des logements respectifs (14).
  2. Fenêtre selon la revendication 1, dans laquelle ladite paire de goupilles est reliée en coulissement au bord inférieur (9a) de ladite partie basculante (3) et est couplée à un dispositif (17, 18, 19, 32) pour actionner leur mouvement de coulissement axial l'une vers l'autre et réciproquement.
  3. Fenêtre selon la revendication 2, dans laquelle ledit dispositif comprend un mécanisme à cames actionné manuellement (17, 18, 19, 32) intégré dans un profilé (23) monté rotatif par rapport au dit élément transversal (11) et relié aux deux extrémités opposées des dites goupilles (12a, b).
  4. Fenêtre selon la revendication 3, dans laquelle le mécanisme à cames comprend un corps en forme de disque (19) solidaire d'une tige (20) supportée par un profilé (23) monté pivotant par rapport au dit
- élément transversal (11), relié de façon excentrée à deux barres de connexion (17, 18) dans une position sensiblement diamétrale, lesdites barres de connexion étant à leur tour reliées aux extrémités opposées des dites goupilles (12a, b), ledit mécanisme à cames étant accessible via une tête de ladite tige pour actionnement au moyen d'une clé spéciale.
  5. Fenêtre selon la revendication 3, dans laquelle ledit mécanisme à cames comprend un corps en forme de disque (19) solidaire d'une tige (20) supportée par un profilé (23) monté pivotant par rapport au dit élément transversal (11), relié de façon excentrée à deux tiges de connexion (17, 18) dans une position sensiblement diamétrale, lesdites tiges de connexion étant à leur tour reliées aux extrémités opposées des dites goupilles (12a, b), ladite tige étant solidaire d'un levier (32) accessible pour son actionnement.
  6. Fenêtre selon l'une des revendications 4 et 5, dans laquelle la rotation du dit corps en forme de disque (19) est soumise à une contrainte élastique.
  7. Fenêtre selon l'une quelconque des revendications précédentes, dans laquelle les autres extrémités des dites goupilles sont reliées en rotation et en coulissement à des supports (15) solidaires du dit élément transversal (11).
  8. Fenêtre selon l'une quelconque des revendications précédentes, dans laquelle ledit élément transversal (11) est réalisé dans une portion de barre en forme sensiblement de H, dans laquelle est positionné un profilé (23) qui y est monté pivotant et solidaire de ladite paire de goupilles (12a, b) via une paire d'épaulements d'extrémité (24) comportant des fentes respectives (25) dans lesquelles est engagée ladite paire de goupilles.
  9. Fenêtre selon l'une des revendications 7 et 8, dans laquelle lesdits supports (15), solidaire de ladite portion de barre (11), comportent des logements respectifs (14) pour les extrémités des dites goupilles (12a, b) alignés avec lesdites fentes des dits épaulements (24), la longueur des dites fentes étant supérieure au diamètre des dits logements, lesdites fentes s'étendant vers ledit profilé.
  10. Fenêtre selon la revendication 9, dans laquelle ledit profilé comporte une arête longitudinale (23a) et au moins deux ouvertures (26) qui coupent ladite arête, lesdites goupilles maintenant des éléments de butée respectifs (28) abutant contre ladite arête lorsque lesdites goupilles sont dans leur première position, le bord inférieur (9a) de ladite partie basculante abutant contre ledit élément de butée (28), sur le côté opposé à ladite arête (23a), après un mouvement

angulaire limité de ladite partie basculante, lesdits éléments de butée pouvant être engagés dans lesdites ouvertures lorsque lesdites goupilles sont ladite seconde position et engagées dans les fentes des dits épaulements, de façon que ladite partie basculante puisse commander ledit profilé (23) en rotation au moyen des dits épaulements (24) autour de ladite portion de barre (11) jusqu'à ce qu'elle soit complètement basculée.

5

10

11. Fenêtre selon l'une quelconque des revendications précédentes, dans laquelle les fentes (24) des dits épaulements sont fermées et ladite paire de goupilles est conçue pour prendre une troisième position dans laquelle les extrémités des dites goupilles sont également sorties des dites fentes pour permettre l'enlèvement de la partie basculante.

15

12. Fenêtre selon l'une quelconque des revendications 1 à 10, dans laquelle lesdites fentes (24) sont ouvertes sur le dessus de façon que, une fois que ladite partie basculante ait été entièrement basculée, les extrémités de ladite paire de goupilles, dans ladite seconde position, peuvent être sorties des dites fentes pour enlever ladite partie basculante,

20

25

13. Fenêtre selon l'une quelconque des revendications 1 à 9, dans laquelle ladite partie basculante (3) comprend un châssis (9), sur les côtés duquel est réalisée une partie en saillie (33), lesdits supports (15) s'étendant jusqu'à la hauteur de ladite partie en saillie (33) et ayant ici un bord en angle (15a), ladite partie en saillie abutant sur ledit bord en angle lorsque lesdites goupilles (12a, b) sont engagées sans les logements respectifs (14) des dits supports (15), de façon à limiter la rotation de ladite partie basculante, permettant en revanche la rotation de ladite partie basculante jusqu'à ce qu'elle soit basculée lorsque cette dernière est abaissée suite à la sortie des dites goupilles (12a, b) hors des logements respectifs (14).

30

35

40

45

50

55



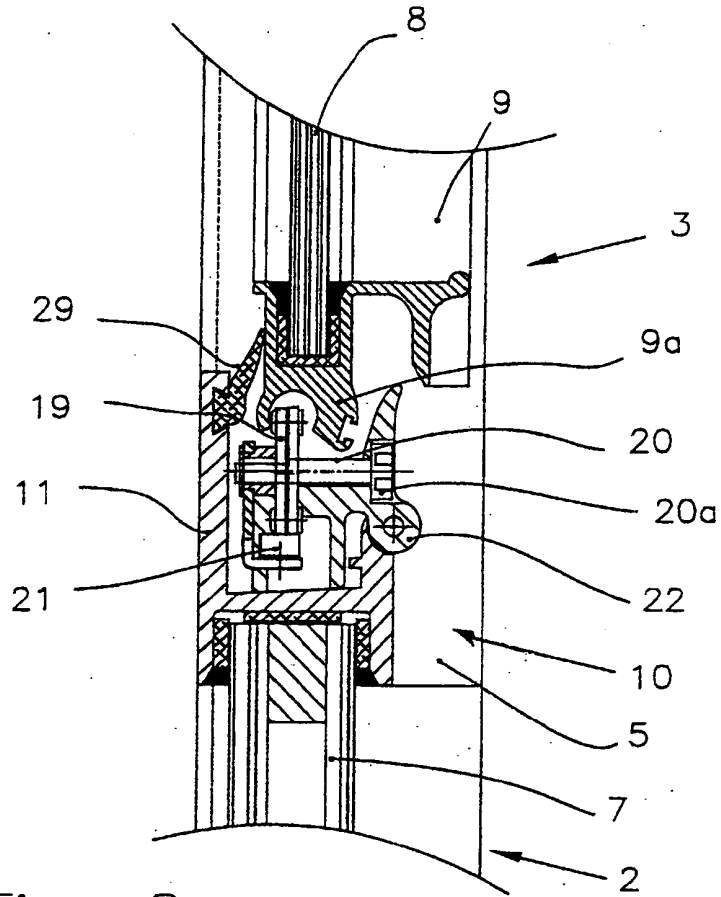

Fig. 2

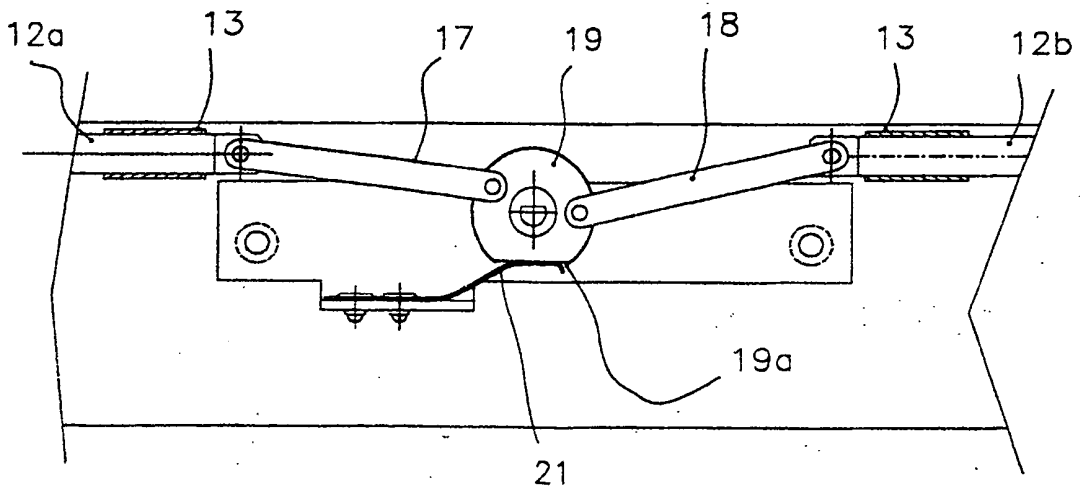

Fig. 3

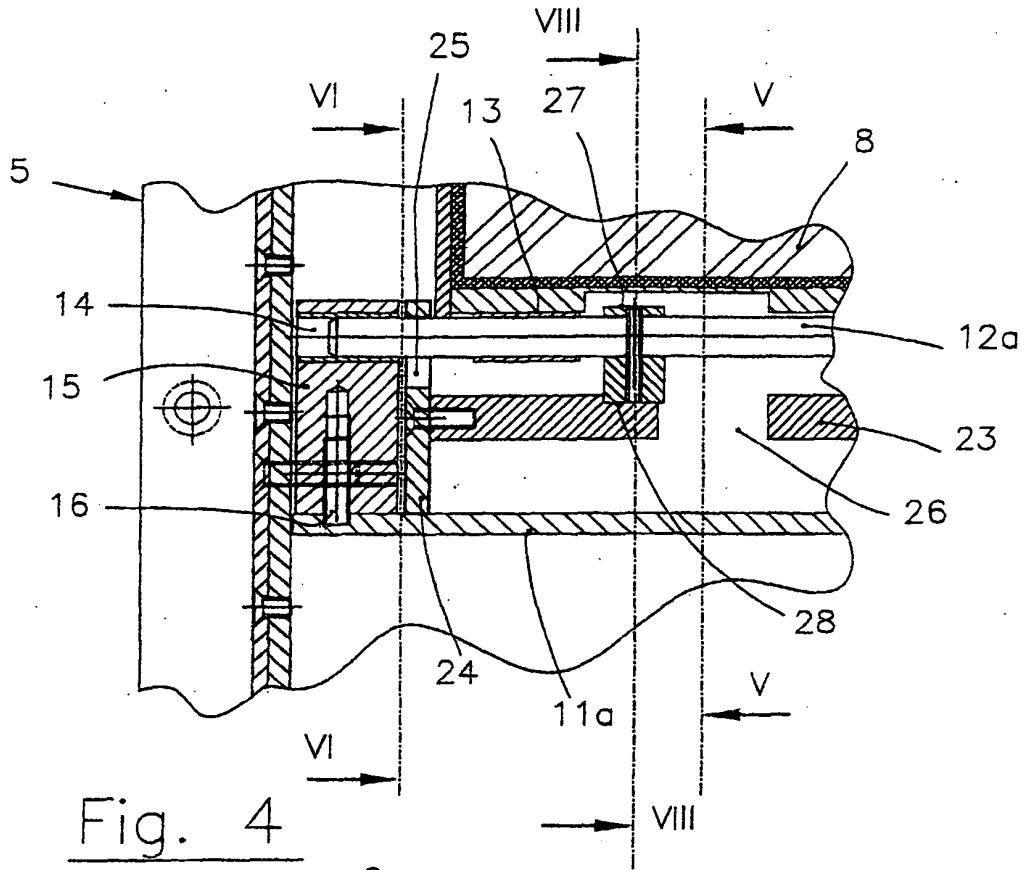

Fig. 4

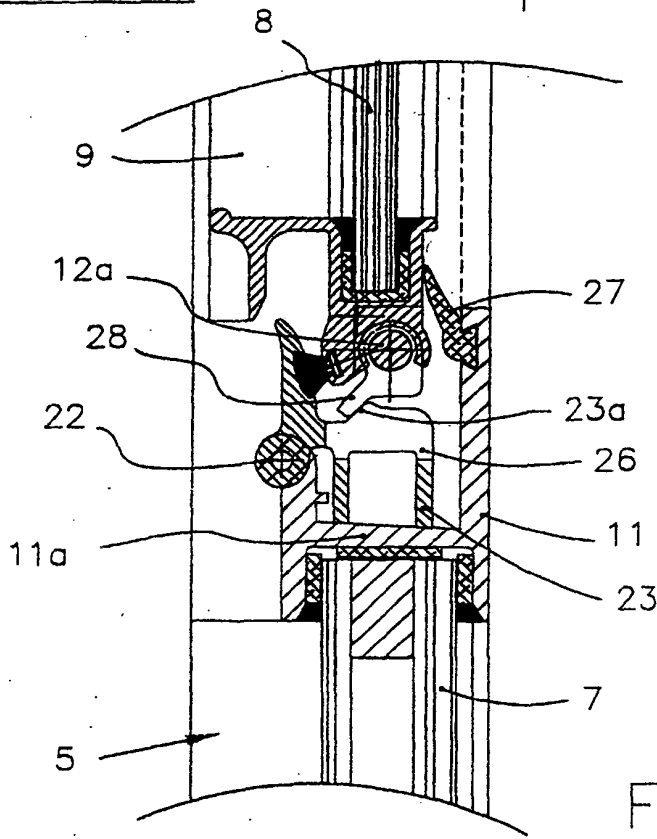

Fig. 5

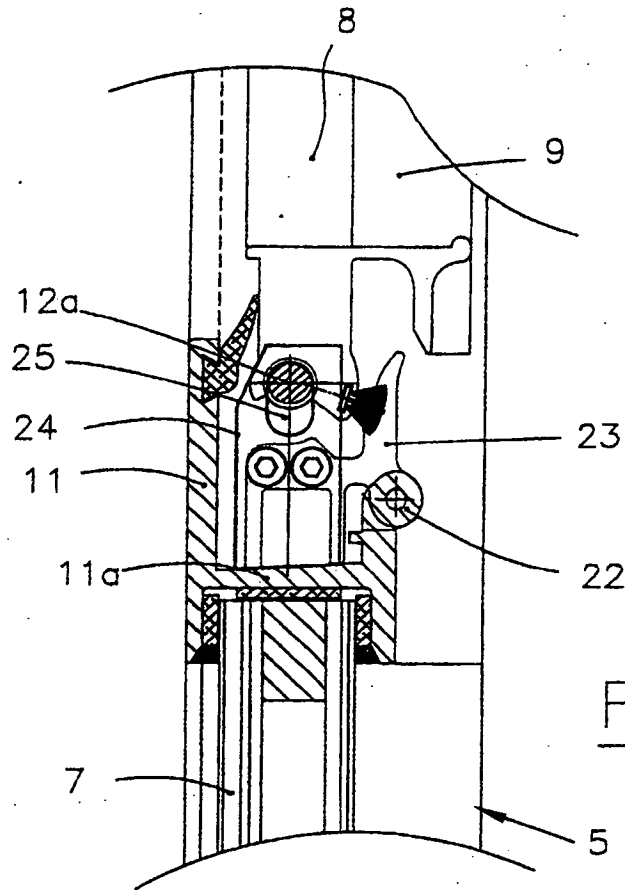

Fig. 6

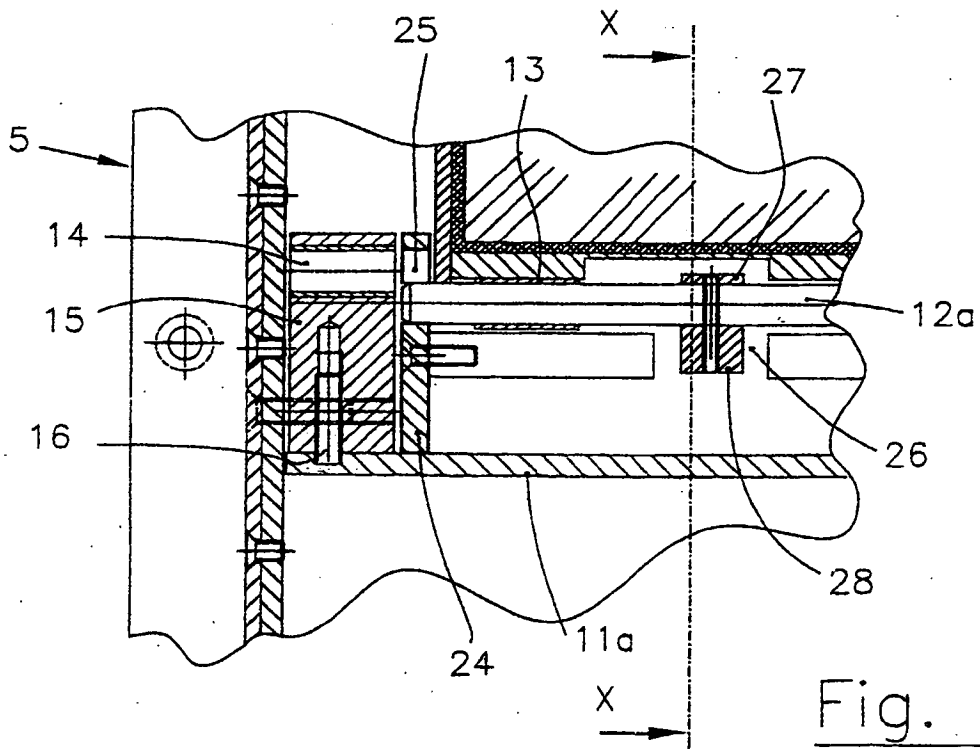

Fig. 7

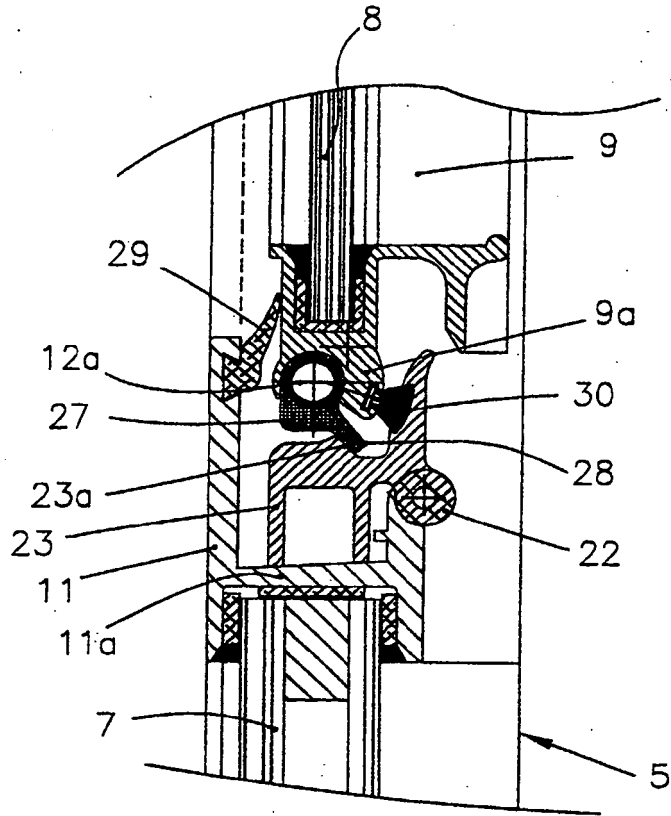

Fig. 8

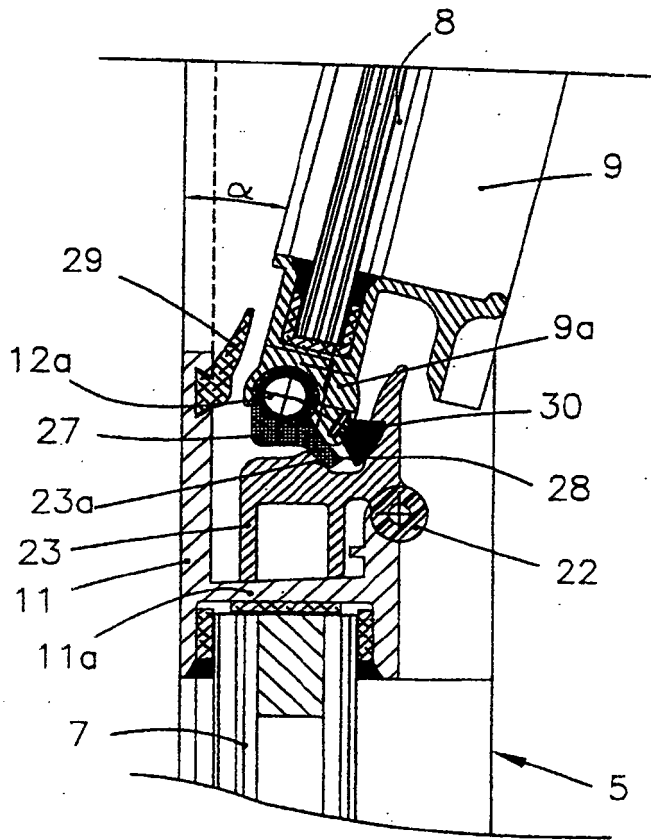

Fig. 9

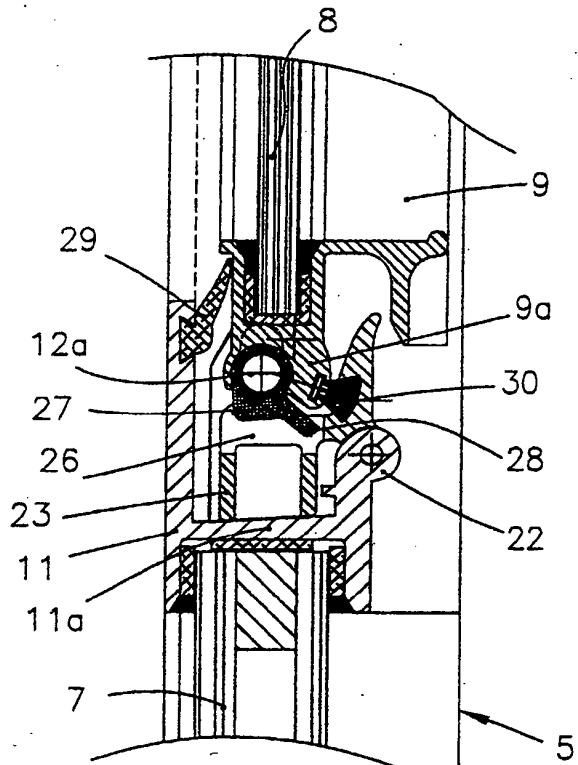

Fig. 10

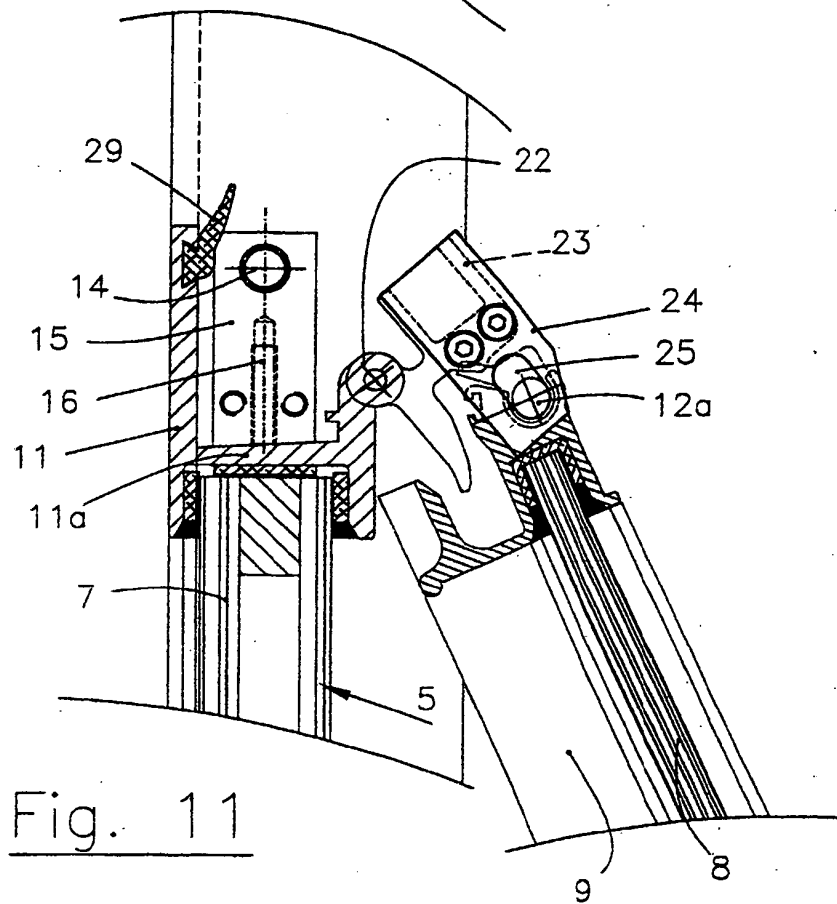
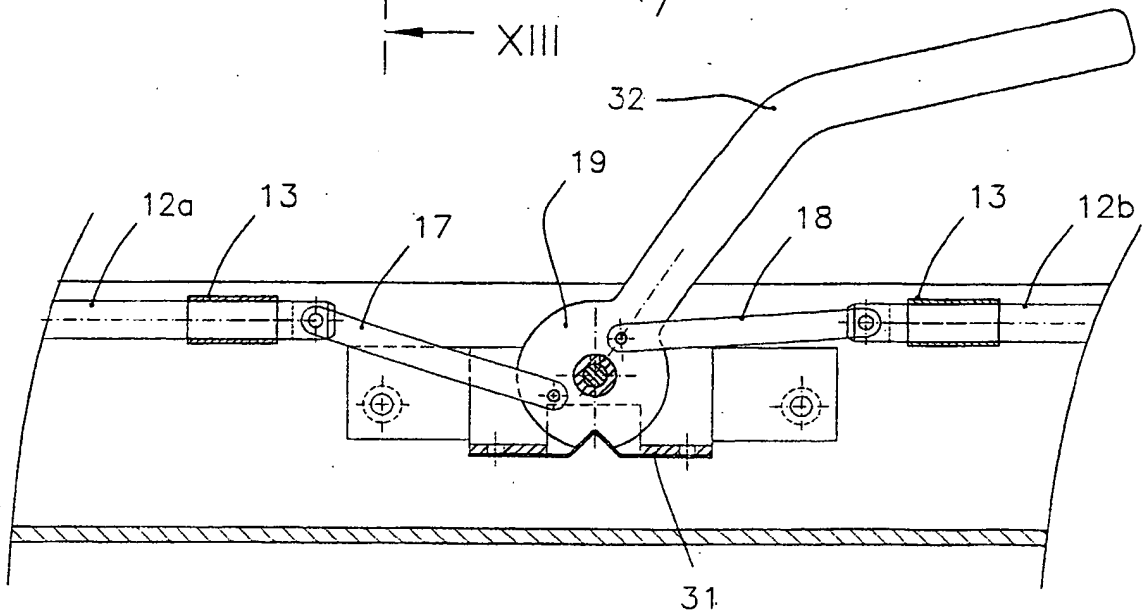
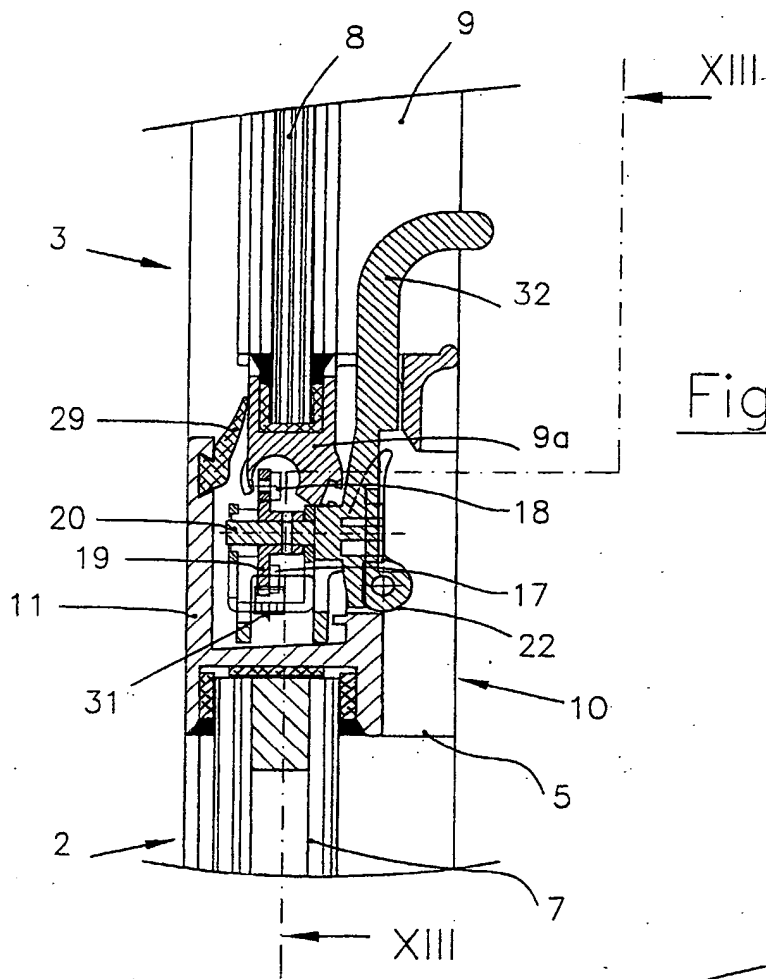

Fig. 11



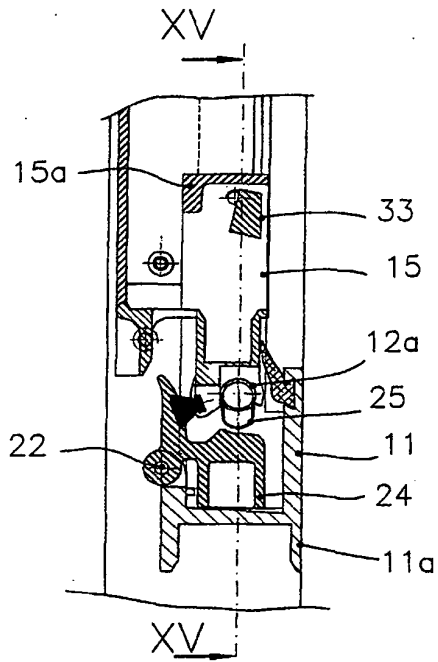

Fig. 14

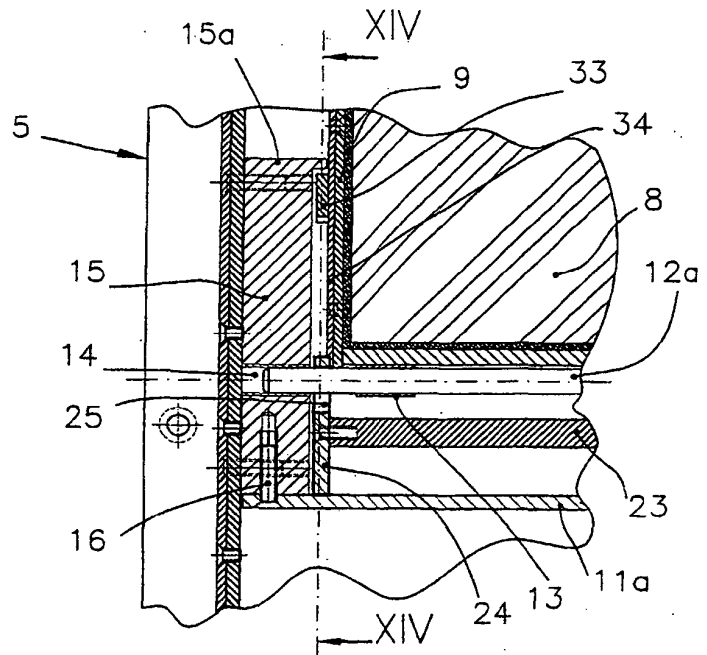

Fig. 15

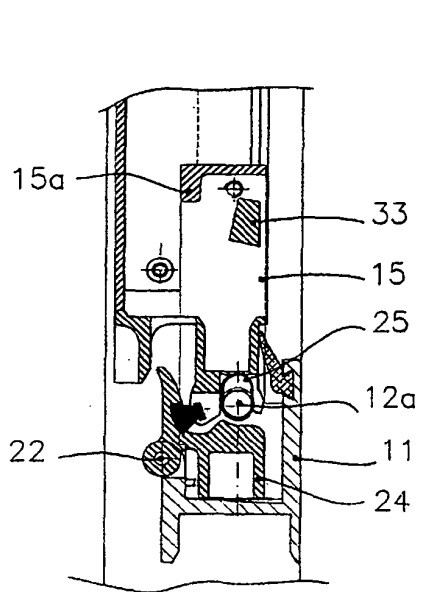

Fig. 16

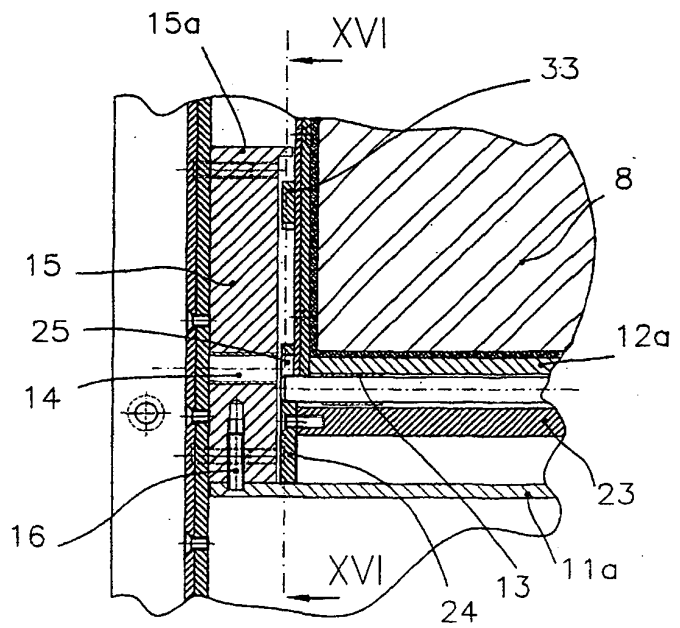

Fig. 17

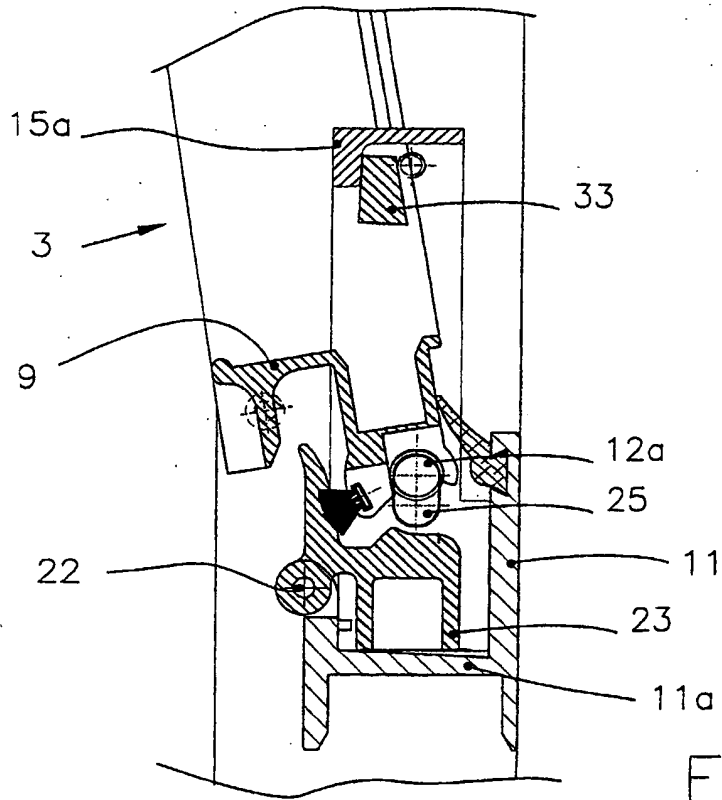

Fig. 18

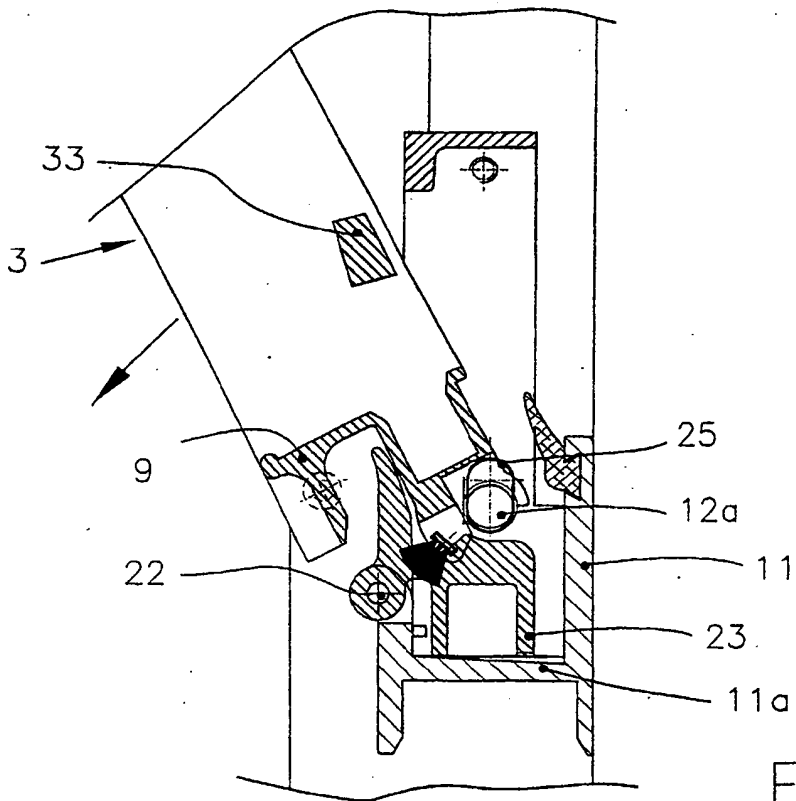

Fig. 19

**REFERENCES CITED IN THE DESCRIPTION**

*This list of references cited by the applicant is for the reader's convenience only. It does not form part of the European patent document. Even though great care has been taken in compiling the references, errors or omissions cannot be excluded and the EPO disclaims all liability in this regard.*

**Patent documents cited in the description**

- US 20030107221 A1 [0004]