

*Almqvist & Ofeldt,*

*Water-Meter.*

*N<sup>o</sup> 100,964.*

*Patented March 22, 1870.*

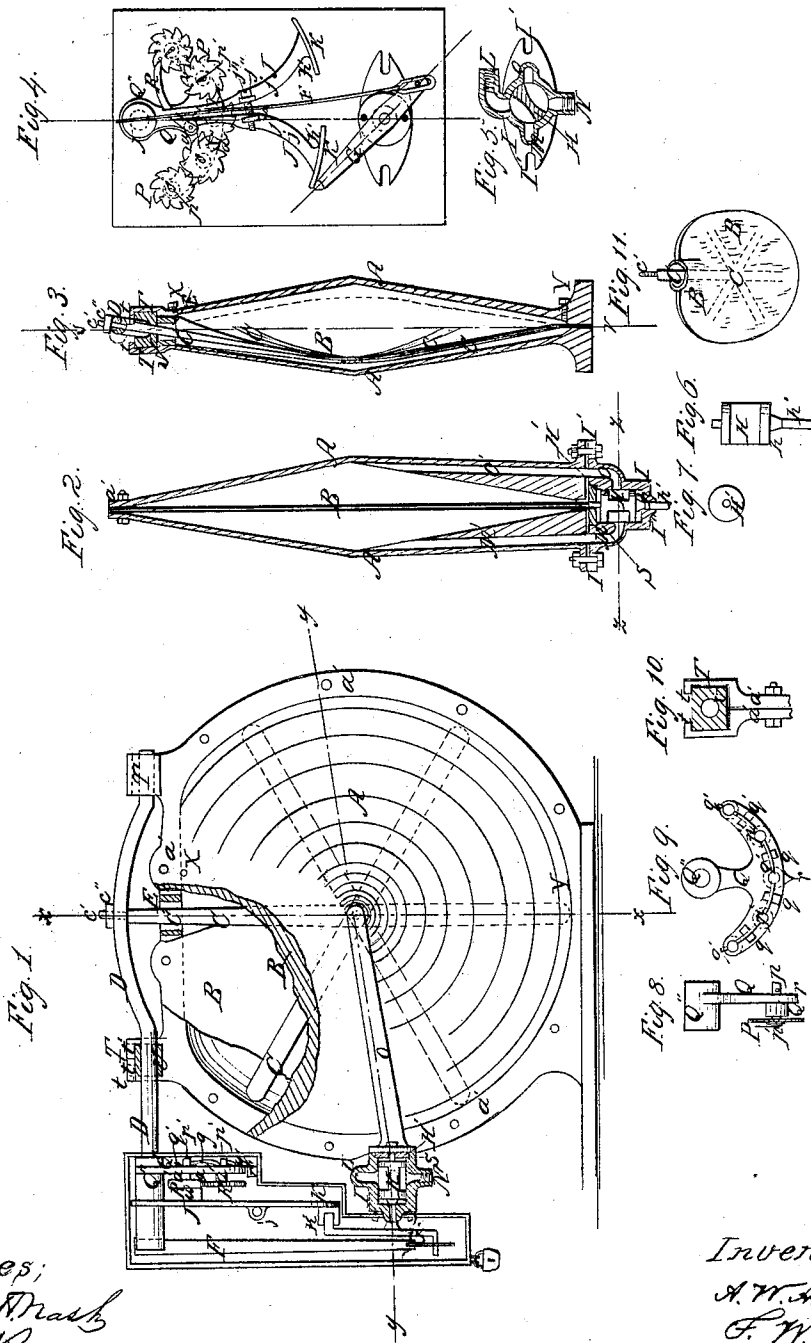

*Witnesses;*  
*Charles S. Nash*  
*Charles Rice*

*Inventors*  
*A. W. Almqvist*  
*F. W. Ofeldt*

# United States Patent Office.

A. W. ALMQVIST AND F. W. OFELDT, OF NEW YORK, N. Y.

Letters Patent No. 100,964, dated March 22, 1870.

## IMPROVEMENT IN WATER-METERS.

The Schedule referred to in these Letters Patent and making part of the same

To all whom it may concern :

Be it known that we, A. W. ALMQVIST and F. W. OFELDT, of the city, county, and State of New York, have invented a new and useful "Improved Water-Meter;" and we do hereby declare that the following is a full, clear, and exact description thereof, which will enable others skilled in the art to make and use the same reference being had to the accompanying drawings forming a part of this specification.

This invention relates to certain improvements in water-meters in general, but especially in the "Almqvist and Ofeldt meter," patented by us January the 19th, 1869; and

It consists in the construction, combination, and arrangement of the various parts, as will be hereinafter described.

Figure 1 represents a side elevation of our improved water-meter, partly in section.

Figure 2 is a central section of the same, taken through the line *y y*, of fig. 1.

Figure 3 is a vertical central section through the line *x z* of fig. 1.

Figure 4 is a face view of the register and device for operating the supply and discharge valve.

Figure 5 is a cross section of the said valve through the line *s s*, fig. 2.

Figure 6, side view of the valve proper.

Figure 7, plan of the disk to which the inner end of the said valve is pivoted.

Figure 8, edge view of the register-supporting plate.

Figure 9, reverse view of the said plate.

Figure 10, end view of journal-box and bearing for the rock-shaft.

Figure 11 is a modification of the diaphragm.

Similar letters of reference indicate like parts.

Meters worked by flexible diaphragms have heretofore proved to be objectionable for several reasons, among which those having reference to incorrect measuring, under different pressures, caused by inclosed air or tardy valves, &c., are removed by the invention described in our patent of January 19, 1869. The remaining objection, viz: the indurability of a rubber diaphragm is mainly due to the fact that it is made to work too heavy valves with too large a stroke, those of the working parts in direct contact with the diaphragm also being acted upon by only a small portion of the said diaphragm, thus exposing said portion to a greater strain than the remaining surface, and thereby causing an increased unequal tension all around, and radiating in diminishing ratio from one point. For the same reason it is obvious that molding the rubber diaphragm in the same shape as the inside of the body of the meter, purporting to allow of a large stroke without straining the elasticity of the rubber, does not overcome this last objection.

To remedy this, we make the inner form of each of the two halves of the outer shell or body A, (fig. 2,) of the meter of the shape of a cone or a spheric segment, the height of which is about one-tenth, not exceeding one-eighth of its base, reducing thereby the stroke accordingly to one-fifth, not exceeding one-fourth of the diameter of the meter.

Our meter for five-eighth inch pipe is thirteen inches in diameter by two and one-half inch stroke, (stroke thus less than one-fifth of the diameter,) supplying one half gallon for every single oscillation.

With such a small stroke the diaphragm B need not be molded in any bulged form, but we make it of a straight sheet, quite thin, and insert it by hanging it between the two halves A, (the latter being placed perpendicularly a little apart,) and then clamp it between the flanges *a* by pressing the parts A together and inserting the bolts.

The deviation from the center line *v v*, (fig. 3,) being only one and one-fourth inches, or one half of the stroke, the elasticity of the diaphragm will not be exerted to any perceptible degree, as its own weight would cause it to swag that much, were it placed horizontally, and thus only its imperviousness and not its elasticity is taken into account for the working of our meter.

C is an elastic frame, formed of flat springs, fastened together at the center, or cut out of one plate of metal, into a shape similar to that shown in fig. 1, said frame reaching through the whole internal width of the meter, one of its radial projections being provided with a screw-thread, *c*, and shoulder, by means of which and the nut *c'* it may be secured through a hole to the rock-shaft D, said shaft D being punched through to receive the screw *c*.

In working the meter, the frame C, at the end of the stroke, will be in the position shown in fig. 3, the elasticity of the frame C allowing its center to travel to the end of the stroke, while its edge, or the ends of its radial projections, remain always in the line *v v*, drawn through the center of the whole meter, and also through the center of the rock-shaft bearings.

The frame C thus acts as and may properly be called a perforated metallic diaphragm, rendered water-tight by means of the rubber covering B.

For convenience sake, the rubber covering B, in figs. 1, 2, and 3, is made of two sheets, and inserted as described, but we prefer molding the rubber covering on and around the metallic diaphragm C, (see fig. 11,) leaving a ring or tube of rubber surrounding the radial projection, which is attached to the rock-shaft D at the point C', (fig. 1,) where the metallic ring E is inserted in said rubber tube for packing between the flanges *a'* of the shells A of the meter.

One great objection to water meters has heretofore been the difficulty of keeping them from leaking

through the stuffing-boxes necessarily used. Even the best stuffing-boxes have to be renewed at least once every year; besides that, in order to be tight, they involve an additional amount of friction, which requires greater pressure or head of water to overcome in working a meter.

In our meter we use no stuffing-box.

The valve-chest I is one piece of casting, having ducts L M N O communicating with the passages M' O' in the parts A of the meter, (said ducts and passages being all formed by cores in casting the metal,) for the purpose of admitting and discharging the fluid.

Said valve-chest I is provided with two lugs I', through which it is secured by bolts to the body of the meter, a sheet of rubber being interposed for packing.

The valve-chest I is bored out in its center to receive the cylindrical valve H, which is pivoted to a disk, H', a little larger in diameter than the valve H, and held firm and water-tight between a shoulder in the valve-chest I and the packing interposed between said valve-chest and the body A of the meter.

The other pivot and bearing for the valve H are the valve-rod *h*' and the solid lid or outer end I'' of the valve-chest I, through which said valve-rod *h*' connects with the device for operating the valve H.

In order to dispense with a stuffing-box and yet prevent leakage around the valve-rod *h*', there is formed on the valve-rod *h*', at the point nearest to the cylindrical valve proper H, a device, *h*, of preferably conical shape, working on or in a corresponding surface in the part I'' of the valve-chest I.

The valve *h* is pressed against its seat with a force proportioned to the area of cross-section of the valve-rod *h*', which force is sufficient to secure its tight working under high pressure, but to hold it close to its seat, even under the lowest pressure, a spring, S, is interposed between the inner end of the valve H and the disk H', as shown in the drawing.

The rigid arm J, attached to the rock-shaft D, and provided with the arched and flanged cross-head K, (as described in our patent of January 19, 1869,) we have improved by making it adjustable.

For this purpose we make it divided nearly up to its hub, (as seen in fig. 4,) forming the arms *j* and *j*', having lugs *j*<sup>2</sup> and *j*<sup>3</sup>, both of which are drilled through, and one of which is threaded to receive the screw *j*<sup>4</sup>, by loosening or tightening which the flanges *k* *k*' may be made to remove from or approach to each other, thereby decreasing or increasing the stroke respectively, and regulating the capacity of the liquid contained for each stroke to the utmost precision, and obviating the necessity of adjusting it with the file, as we have done heretofore.

On the opposite or inner side of the arm J is formed a hub, *w*, to which we attach the pawl R for working the register P.

The wheels of the register work against hubs Q', formed on the plate Q, which plate is supported by the rock-shaft D passing through a hole in the hub Q'' of the plate Q, said hole being large enough to allow of the free motion of the shaft D without moving the plate Q with it.

On the back of the plate Q, between each successive hubs Q', are formed little curved projections *q*.

*r* is a projection on the lower part of the plate Q, intended to prevent it from swinging with the movement of the shaft D, by being held in position in a notch or similar contrivance attached to the casing, shown in fig. 1.

Passing through the hubs Q', and holding the wheels of the register P, are the indices *p*', each of which consists merely of a wire with the pointer attached to its outer end, and having a hole in its inner end close to the back of the plate Q. These holes are drilled at right angles to the direction of the pointers.

After the register-wheels and indices have been placed in position, an elastic steel or brass wire, *q*', is drawn through the said holes, resting on the projections *q* between the index-pins *p*'. This wire serves for two purposes, viz:

First, it prevents the pointers from turning, thereby allowing the registering to be indicated by the number on its wheel, which, as the wheel revolves, passes opposite to the end of the corresponding pointer.

Second, the wire *q*' being held in tension by the projections *q*, on the plate Q, pulls the index-pins *p*' inward, which presses the wheels of the register against the face of the hubs Q', thereby producing enough of friction to prevent the wheels from turning in the wrong direction when the pawl R has dropped one tooth and retires to catch another.

For accessibility in building the meter, the rock-shaft D is bent, as seen in fig. 1, and inserted in the journal boxes T, at the same time as the diaphragm C, after which the bearings U are put on from the ends of the shaft D, until they lodge in the boxes T.

The square boxes T are formed on the two parts of the body A of the meter in casting the same, as shown in the drawing, and provided with small stops *t* *t* at the upper edge, to prevent the bearings U U from being lifted out of the boxes T, and, at the same time, to allow the inserting of a wedge at the space *t*' between them to prevent any lateral movement of the bearing, if necessary.

To insure the easy working of the shaft, as well as cheapness, and prevent any friction from rust, the bearings U are made of wood, and dipped in oil before being put on the shaft D and inserted in the boxes T T.

X is a hole for a screw plug at the upper flange of the meter, to be closed after the water has expelled the air when starting the meter.

Y is a similar hole at the lower flange for emptying when not in use.

Having thus described our invention,

What we claim as new, and desire to secure by Letters Patent, is—

1. The combination of a metallic diaphragm a trifle less in diameter than the interior diameter of the body or shell A, flexible throughout its whole extent, and covered with rubber or equivalent water-proof material, with the rock-shaft D and body or shell A, substantially as herein shown and described and for the purposes set forth.

2. The combination of the device *h* with the cylindrical valve H, both revolving upon the same axis, but working against different surfaces in the same valve-chest I, substantially as shown and described, for the purposes of dispensing with a stuffing-box, preventing leakage and reducing friction.

3. The combination of the continuous wire *q*' with the projections *q* on the plate Q, and with the indices *p*', for the double purpose of preventing said indices from turning, and, at the same time, by its tension, produce the necessary friction between the registering-wheels and their hubs on the plate Q, as described.

4. The device for adjusting the measurement, viz: the combination of the arms *j* and *j*' with the screw *j*<sup>4</sup>, as described.

5. The peculiar manner described and shown of attaching the plate Q for the purpose of avoiding any lateral strain on the rock-shaft bearings in working the register.

The above specification of our invention signed by us this 27th day of February, 1869.

A. W. ALMQVIST.  
F. W. OFELDT.

Witnesses:

CHARLES H. NASH,  
CHARLES NIDA.