

(No Model.)

2 Sheets—Sheet 1.

A. DÉCOMBE & P. LAMENA.
ACTUATING THE VALVES OF STEAM ENGINES.

No. 525,005.

Patented Aug. 28, 1894.

FIG-1 -

FIG-5 -

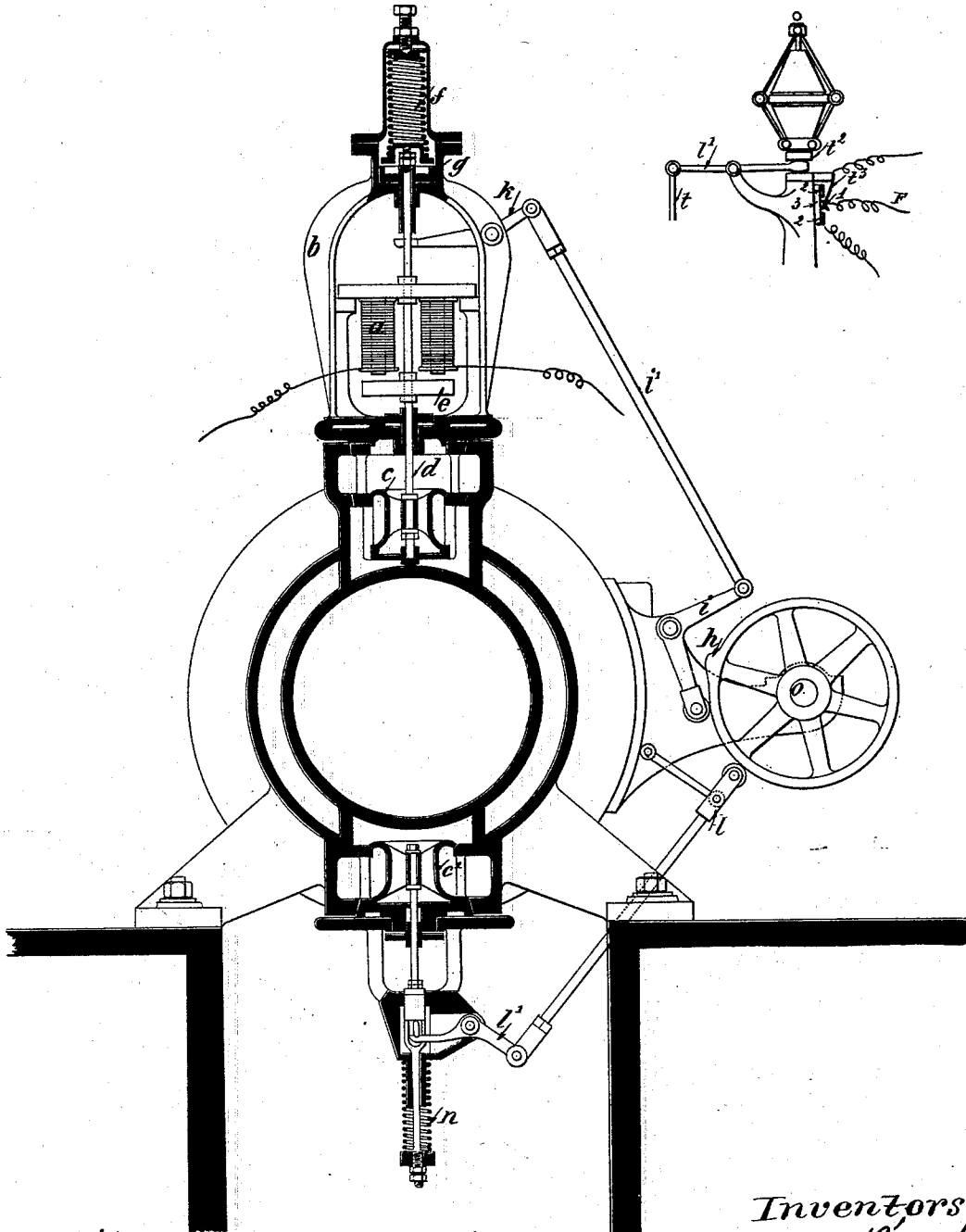

Witnesses:
John Preston Beecher
[Signature]

Inventors:
[Signature]
Pierre Lamena

(No Model.)

2 Sheets—Sheet 2.

A. DÉCOMBE & P. LAMENA.
ACTUATING THE VALVES OF STEAM ENGINES.

No. 525,005.

Patented Aug. 28, 1894

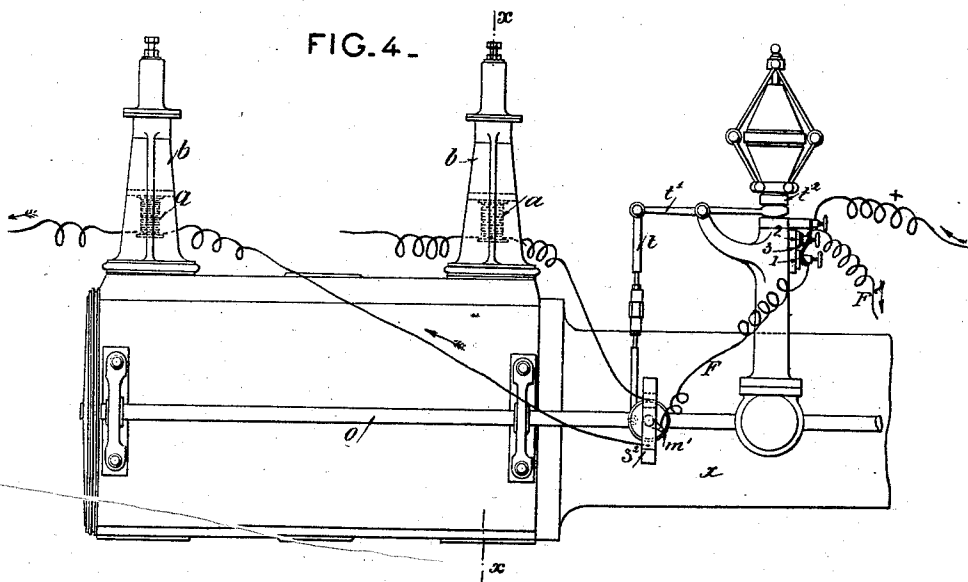
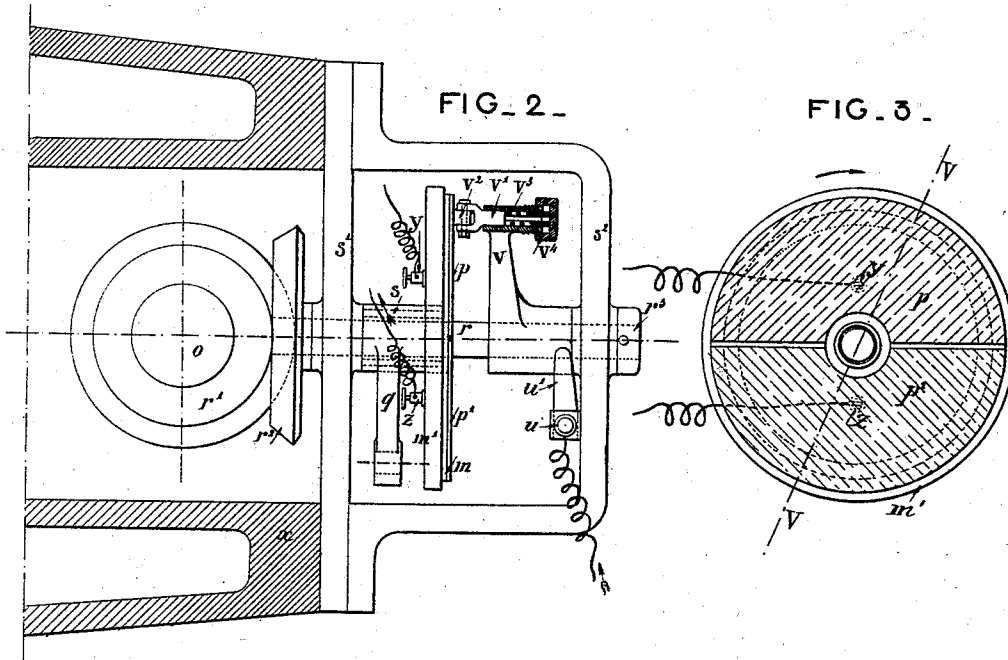

Witnesses:

John Preston Beecher

Inventors:

Amédée Décombe
Pierre Lamena

UNITED STATES PATENT OFFICE.

AMINTHE DÉCOMBE, OF BORDEAUX, AND PIERRE LAMENA, OF PAUILLAC,
FRANCE.

ACTUATING THE VALVES OF STEAM-ENGINES.

SPECIFICATION forming part of Letters Patent No. 525,005, dated August 28, 1894.

Application filed March 14, 1894. Serial No. 503,605. (No model.) Patented in France October 30, 1893, No. 233,737.

To all whom it may concern:

Be it known that we, AMINTHE DÉCOMBE, engineer, of Bordeaux, and PIERRE LAMENA, notary, of Pauillac, Department of Gironde, both in the Republic of France, have invented certain new and useful Improvements in Actuating or Operating the Valves of Steam or other Motive Power Engines, (for which we have obtained Letters Patent of France, dated October 30, 1893, No. 233,737,) of which the following is a full and exact description, reference being made to the accompanying drawings.

This invention relates to actuating or operating the valves of steam and other motive power engines and has for object an improved application of electricity and magnetism to advantageously produce the distribution of steam in steam engines.

By the simplicity, precision and the economy effected by our improvements a steam engine provided therewith is capable of rendering effective service in manufactories and all industries which require considerable motive power and particularly industries which require great regularity in the working of the motors.

In order to enable the invention to be fully understood we will describe the same by reference to the accompanying drawings which demonstrate our system of electro-magnetic distribution applied to steam engines of the Sulzer type.

Figure 1 is a vertical section of the cylinder taken on the line $x-x$ of Fig. 4. Figs. 2 and 3 are details of the commutator. Fig. 4 represents a view of the steam cylinder and connecting parts with the electrical connections for regulating the action of the valves. Fig. 5 shows an arrangement for electrically stopping the machine in the two extreme positions of the centrifugal governor. Figs. 4 and 5 are drawn on a reduced scale.

Corresponding letters and figures of reference throughout the different views refer to corresponding parts.

An electro magnet a (Fig. 1) is fixed to the frame b and arranged in such a manner that its two poles are situated opposite the inlet valve c and in a plane perpendicular to the axis of the rod d of this valve.

The electro magnet has for object to hold the valve c raised during the admission of steam to the cylinder. For this purpose the rod of the valve supports an armature e fixed on this rod; this armature at the moment of the opening of the valve bears against the two poles of the electro magnet a and maintains this position so long as the current passes to the coils. Immediately the current is broken the electro magnet a is no longer magnetized and abandons the armature e ; at this moment, the rod d under the action of a helical spring f quickly closes the valve which again falls on its seat, an air piston g being provided to prevent shock.

The current necessary for the successive magnetization of the electro magnet a is furnished by means of a small electrical machine driven by the engine itself. The current from the electrical machine passes first through a commutator (Figs. 2 and 3) placed directly beneath the governor and which breaks the current passing through the coils at the instant compression commences in the motor cylinder. This commutator or distributor of the current is hereinafter described.

As in the Sulzer machine, parallelwise to the axis of the cylinder is placed the distributing shaft o driven by the motor shaft by means of bevel gearing. This distributing shaft o operates the regulator and commutator also by means of bevel gearing.

On the shaft o are keyed four cams, one opposite each valve, and these cams operate the valves by means of levers in a well known manner.

The cams h which actuate the inlet valves are constructed so as to obtain a minimum introduction, which is limited here to one-tenth of the volume of the cylinder.

The commutator (Figs. 2 and 3) which regulates the distribution allows of the admission being varied from 0.10 to near 1.00 to work equally well with rapid movements of the piston.

For the purpose of obtaining a minimum introduction of one-tenth by the employment of the cam h it is only necessary to give the latter a larger diameter as shown in Fig. 1. Under these conditions it possesses the advantage of effecting a complete and rapid open-

ing of the valve (of about one twenty-fifth to one-thirtieth of a second) and consequently of avoiding the wiredrawing of the steam as it enters the cylinder.

5 The cams which operate the inlet valves being keyed upon the shaft *o*, the extent of opening of the valve for the admission of the steam will be constant; as to the closing this will depend upon the position of the governor
10 as will be hereinafter described.

From the foregoing it is easy to understand that at the moment of the introduction of steam into the cylinder, the cam *h* quickly and completely opens the inlet valve *c*, brings
15 into contact with the poles of the electro magnet *a* the armature *e* which does not separate therefrom to effect the closure of the valve until the current is broken.

The variations of the admission of steam
20 into the cylinder therefore depend only upon the duration of the current which passes in to the coil of the electro magnet during the period comprised between the opening and closing of the inlet valve and consequently upon
25 the commutator which regulates the duration of this current.

The cam *h* operates the inlet valve by means of a bent lever *i*, one arm of which carries a roller on which the cam acts at the commence-
30 ment of the admission; the other arm is jointed to a rod *j* which is connected to one end of a bent lever *k* which operates the rod of the valve *c*. The closure of this valve is insured by the helical spring *f* which acts at the same
35 time upon the air piston *g*.

The outlet valves are operated in the same manner as in the Sulzer machines; the cams which operate these valves have the same diameter as those above described for the purpose of obtaining a quick opening and closing of the outlet opening. The cam *h* acts directly upon the rod *m* provided at one of its ends with a roller which, during its movement turns upon the cam, the other end is
45 jointed to a bent lever *l* which operates the rod of the outlet valve *c'*; the closing of this valve is insured by a helical spring *n*. The cam is made in such a manner as to obtain a constant discharge and compression of the
50 steam which has been expanded to the end of the stroke of the piston.

The commutator is composed of a circular plate of ivory *m* (Figs. 2 and 3) on the face of which are fixed two metal plates *p*, *p'*, as
55 shown in Fig. 3, by hatch lines, and which are separated from each other by suitable insulating material. These metal plates have somewhat the form of two semi-circles having for a common center the center of the
60 plate *m*.

The plate *p* is in permanent connection with the electro-magnet which regulates the distribution at one end of the cylinder; the plate *p'* is in permanent connection with the
65 electro-magnet which regulates the distribution at the other end of the cylinder.

The ivory plate *m* is fixed on a circular

metal plate *m'* keyed on the boss of a crank *q*; the two plates *m*, *m'* are concentric with the axis of this boss. The whole of the plates
70 *m*, *m'* are placed directly in communication with the governor by means of a rod *t* (Fig. 4) jointed at the ends respectively to the crank *q* and to the lever *t'* which operates the sleeve *t''* of the governor.
75

The boss of the crank which is movable around its axis is mounted in slight frictional contact and without play upon the socket *s* fixed to a support *s'* of the apparatus. If necessary a washer is secured to the end of
80 the socket to prevent any movement of the boss of the crank *q* in the direction of its longitudinal axis. In the same axial line is the socket *s* and perpendicularly to the face of the plate *m* is placed a small shaft *r* which
85 receives rotary movement and is driven by the distributing shaft *o* by means of two equal bevel wheels *r'*, *r''* so that its circular velocity is the same as that of the fly wheel of the machine. This shaft *r* is supported at its ends
90 by two supports *s'*, *s''* bolted to the frame X of the machine; one of the ends of this shaft *r* carries the bevel wheel *r''* which communicates to it its movement of rotation; at the other end is fixed a washer *r'''* which prevents
95 any displacement in the direction of the lengths of the shaft.

On the part of the shaft *r* which is near the metal plates *p*, *p'* is keyed a crank *v* insulated from the shaft. During the rotation of
100 the shaft *r* the end of the crank *v* remains constantly in contact with the plane surface formed by the metal plates *p*, *p'* and the insulating material which supports them for this purpose.
105

The end of the crank *v* receives the small rod *v'* of square section the axis of which is perpendicular to the plane of the plate *m* and which can slide in frictional contact and without play in a mortise of the same section as
110 this rod formed in the end of the crank.

The rod *v'* carries at its end a roller *v''* which bears lightly on the surface *p*, *p'* of the plate; the contact of the roller with this surface is constantly insured by the small spring *v'''* the
115 tension of which can be regulated as desired by means of a nut *v''''*.

A terminal *u* fixed on a support *s''* and perfectly insulated is in permanent communication with the crank *v* by means of a flat spring
120 *u'* which, during the movement of rotation of the shaft *r* constantly rubs on the boss of this crank. This terminal *u* receives the end of the positive wire of the dynamo.

Two similar terminals *y*, *z* are fixed on the
125 plate *m'* and perfectly insulated from this plate; each of these terminals communicates with a metal plate and receives the wire which establishes a communication between the metal plate *p*, *p'* and the electro-magnet.
130

The operation of the commutator will be easily understood.

The current produced by the small electrical machine arrives first at the terminal

u and thence passes to the roller v^2 which, during its movement of rotation around the shaft r comes into contact alternately with the metal plates p, p' and consequently alternately opens and closes the current in each of the electro-magnets a .

In order to describe the action produced by the governor to effect the admission it is sufficient to go back to the description of the movement of the admission valves. The distributing cams being keyed on the shaft o the extent of the opening of the valve for the admission of the steam will consequently be constant, this position of the admission cam will correspond to a position of the crank v which will be always the same in the space and which is shown, in Fig. 3, by the dotted line $V V$ which line indicates the positions of planes laid through the axis of the crank shaft and the axis of roller v^2 . There is also shown in the same figure by two dotted lines the path traversed by the roller v^2 which, having a movement of rotation in the direction of the arrow as soon as the roller arrives in contact with the dotted line $V-V$ the admission commences in the cylinder. This admission will take place at one or other of the ends of the cylinder according to whether the roller is in contact with either the one or the other of the metal plates p, p' . The admission will cease immediately the roller comes in contact with the insulating material placed between the metal plates.

As the dotted line $V V$ always occupies the same position in the space it is evident that the admission will depend upon the position of the plate m with relation to these dotted lines and according to whether this plate has a small displacement or movement in one direction or the other, the admission will be increased or diminished.

It is easy to modify according to desire the introduction of the steam by lengthening or shortening the rod t (Fig. 4) which operates the plate m . For this purpose the rod is made in two parts the ends of which are screw threaded with threads cut in opposite directions and connected by a nut; it will thus be seen that by turning this nut in one or other direction the position of the plate m may be varied, that is to say, the introduction can be increased or diminished. To prevent the engine running at too great a speed we employ the following arrangement which is very simple and has for object to interrupt the current in the wire F (Fig. 4) which establishes communication with the commutator in order to send it to a closed circuit which, by producing the disengagement of a counter-weight, will close the admission valve.

On the sleeve t^2 of the governor is fixed a small flat spring t^3 ; during the movement of the governor the end of this spring rubs lightly on the plane surface of two metal plates 1, 2 fixed on an ivory plate 3, and separated one from the other by a small space.

The ivory plate 3 is fixed on the framing

of the governor at a suitable height in order that at the moment the engine commences to race the spring t^3 may be put in contact with the plate 2. This spring t^3 is insulated from the sleeve on which it is fixed and communicates with the positive pole of the electrical machine. The plate 1 communicates by means of the conducting wire F with the commutator.

The plate 2 communicates by means of the wire F' with an electro-magnet which, by its temporary magnetization, effects the disengagement of the counterweight and thereby the closing of the admission valve the other end of the wire which is wound on the bobbins of the electro-magnet communicates with the dynamo machine so as to constitute a closed circuit when the spring t^3 is in contact with the plate 2.

During the normal working of the engine the spring t^3 remains constantly in contact with the plate 1 and the current is sent into the commutator.

If from any cause whatever the machine commences to race, the sleeve t^2 of the governor is raised as well as the spring t^3 which is put in contact with the plate 2 and the current is then sent to the electro-magnet which will effect the closing of the admission valve.

In the case where it would be necessary to stop the engine in the two extreme positions of the governor we employ the arrangement shown in Fig. 5. The plate 1 of the construction described with reference to Fig. 4 is placed between two portions of the plate 2. When the spring t^3 rubs upon the plate 2 the working is normal, that is to say, the current passes from the spring t^3 to F' and thence to the commutator. But if the governor races or falls to its lowest position the spring rubs from top to bottom of the plate 2 and the current passes from t^3 to F' .

Our electro-magnetic system of distributing steam is obviously applicable to all kinds of distribution effected by valves, by slide valves, plain, cylindrical or otherwise, modifications being made to suit the different applications, and it may even be used for gas and petroleum motors.

We claim—

1. In combination with an engine and its inlet valves, mechanical means for opening said valves, electro-magnets mounted on stationary frames for holding such valves open, and a commutator for breaking the electric circuits controlling said magnets, substantially as set forth.

2. In combination with an engine and its inlet valves, mechanical means for opening said valves, electro-magnets mounted on stationary frames for holding such valves open, and means actuated by the movement of the engine for breaking the electric circuits controlling said magnets, substantially as set forth.

3. In combination with an engine and its inlet valves, mechanical means actuated by the engine for opening said valves, electro-

magnets mounted on stationary frames for holding the same open, and a commutator connected with the governor of the engine for breaking the electric circuits controlling said magnets, substantially as set forth.

5 4. The combination with an engine and its inlet valves, of an auxiliary shaft, as O, driven by the engine, cam mechanism actuated by such shaft and adjusted to open the inlet
10 valve, electro-magnets mounted on stationary frames for holding such valves open, and a commutator on said auxiliary shaft for breaking the electric circuits controlling said magnets, substantially as set forth.

15 5. In combination with an engine and its inlet valves, means for opening said valves, electro - magnets mounted on stationary frames for holding such valves open, a commutator for intermittently breaking the elec-
20 tric circuits controlling said magnets, and a

switch actuated by the governor, for cutting the commutator out of circuit, substantially as set forth.

6. In combination with an engine and its inlet valves, means for opening said valves, 25 electro - magnets mounted on stationary frames for holding such valves open, a commutator for intermittently breaking the electric circuits controlling said magnets, and a switch actuated by the governor for shifting 30 the current from the commutator to a circuit controlling means for closing the admission valve, substantially as set forth.

In witness whereof we have hereunto set our hands in presence of two witnesses.

AMINTHE DÉCOMBE.
PIERRE LAMENA.

Witnesses:

JOHN PRESTON BEECHER,
E. VARLET.