



(22) Date de dépôt/Filing Date: 2007/10/10

(41) Mise à la disp. pub./Open to Public Insp.: 2009/04/10

(51) Cl.Int./Int.Cl. *F24J 2/40* (2006.01)

(71) Demandeur/Applicant:
VERWAY, JOHN A., CA

(72) Inventeur/Inventor:
VERWAY, JOHN A., CA

(54) Titre : SYSTEME DE CONTROLE ET / OU DE PROTECTION DE L'EXPLOITATION D'UNE INSTALLATION DE
CHAUFFAGE DE LIQUIDE

(54) Title: OPERATING CONTROL AND / OR PROTECTION SYSTEM FOR FLUID HEATING

(57) **Abrégé/Abstract:**

A system of controls, valves, sensors and wiring used with a fluid heating system such as solar thermal to prevent the temperature from exceeding the set point and / or protect the system from undesired temperatures. Regular propylene glycol or other heat transfer fluid can be used. The system can be plumbed in PEX pipe, copper or other tubing. No dump load is needed. Excessive high temperatures and high pressure is eliminated. This system design works in all conditions including pump failure and power outages.



Patent application

Fluid heating “operating control and / or protection system”

Abstract

A system of controls, valves, sensors and wiring used with a fluid heating system such as solar thermal to prevent the temperature from exceeding the set point and / or protect the system from undesired temperatures. Regular propylene glycol or other heat transfer fluid can be used. The system can be plumbed in PEX pipe, copper or other tubing. No dump load is needed. Excessive high temperatures and high pressure is eliminated. This system design works in all conditions including pump failure and power outages.

Technical Field

This system can be used in the heating and cooling industry including solar hot water.

Patent application

Fluid heating “operating control and / or protection system”

Background information and prior art.

Because sunshine and weather cannot be controlled, the solar water heating industry has been addressing the issue of unregulated high and low temperatures in solar collectors. The invention possesses numerous benefits and advantages over known systems. In particular, the temperatures can be controlled by a system of controls, valves, sensors and wiring that drains the system when temperatures reach a programmed setting.

One of the prior art solutions was to create high / low temperature propylene antifreeze to withstand this. Another solution is to use a dump load in the form of a metal block where the heat transfer fluid would dump excess heat by passing through it. Other systems dump hot water to a drain thereby cooling the reservoir as cold water is added.

Solar systems typically must be plumbed in copper and brazed instead of soldered. In the event of a power outage the temperature of the antifreeze in the collectors would continue to rise and the pressure increases. Dump loads could fail because circulation has stopped. Some dump loads are designed to operate in these conditions using a thermal syphon.

Some solar controls will drain a system when it reaches a set point. These fail if a power outage occurs because the drain valve is reliant on power to open. Sensor failure in these controls also cause system overheating.

The industry in general is in agreement that systems, due to these uncontrolled temperatures, cannot be plumbed using Pex pipe.

The following patents are relevant to these systems.

CA 506879) TEMPERATURE CONTROL SYSTEM INCLUDING SOLAR HEAT COMPENSATING ELEMENTS

CA 1080566 TEMPERATURE CONTROL IN SOLAR-TO-THERMAL ENERGY CONVERTERS
Solar-to-thermal energy converter comprising an insulated frame, a solar energy absorber mounted in the frame, a fluid flow heat exchange means thermally coupled to the absorber to carry away as thermal energy the absorbed solar energy, and...

CA 1139945 SOLAR ENERGY COLLECTOR AND SYSTEM Solar collectors whose absorbers are made of a conventional building material form the outer surface of the roof and wall of a building. Air flows behind the absorbers

CA 1159329 CYLINDRICAL ROTARY CONTROLLER FOR A SOLAR HEAT SYSTEM A modular solar heat controller contains four chambers through which heated air is deflected to an area of need, such as a house or building. One of the chambers

CA 1201888 THERMAL ENERGY STORAGE SYSTEM A thermal energy storage system for absorption of heat from a heat source having a temperature above a predetermined temperature and release of heat to a heat sink having a temperature below the predetermined temperature. The system comprises a heat storage mass comprising a condensed state material which changes between the solid and liquid

CA 2160358 THERMAL CONTROL APPARATUS A heat exchanging apparatus (20, 25; 27, 29) including a working fluid (26) and a structure for exchanging heat between the working fluid and an external environment. The structure includes at least one wall element (28) having an external surface

CA 2253928 EQUIPMENT AND PROCESS FOR HEAT ENERGY STORAGE Pieces of equipment (1) for heat energy storage, possible for solar heat storage where heat is collected by solar energy collection equipment. It consists of the following parts: sun radiation concentrator assembly (7), a heat source (7a) located in the focus of the above (7) assembly, a forward primary pipeline (8) connecting the heat source (7a) with the heat container (2) of the heat-storage equipment (1) as well as a backward secondary pipeline

CA 2512754 METHOD AND APPARATUS FOR SOLAR COLLECTOR WITH INTEGRAL STAGNATION TEMPERATURE CONTROL This invention relates to a method and apparatus for a solar collector having integral control of the maximum temperature that it can reach, thereby avoiding excessive stagnation temperatures in the collector. In one embodiment, a solar collector comprises a top portion comprising glazing, a bottom portion; an absorber disposed between said top portion and said bottom portion for absorbing solar energy received through said glazing, said absorber in a spaced relationship above said bottom portion such that a channel is defined between a lower surface of said absorber and an upper surface of said bottom portion; an inlet and an outlet associated with and at substantially opposite ends of said channel between said absorber and said bottom portion, for ventilating said channel; and a damper for opening said outlet at a temperature equal to or above a first selected temperature and for closing said outlet at a temperature equal to or below a second selected temperature; wherein said first and second selected temperatures are below a stagnation temperature of the solar collector.

CA 2572299 SOLAR ENERGY CONTROL A solar energy collection system includes a solar concentrator operative to direct a concentrated solar beam onto a solar receptor. A shutter plate is positioned between the solar concentrator and the solar receptor and is movable from an open position adjacent to the solar beam, to a closed position wherein at least a portion of the solar beam

Searches conducted

((solar temperature control)) no patents

solar controls 63 results nothing close

Solar over heat nothing found

regulate solar temperature nothing found

control solar temperature nothing found

Description of an application

Refer to drawings CETT (E) and CETT (P) along with the Key Guide.

A pressure pump with a pressure limit switch draws heat exchange fluid from a 5 to 10 gallon reservoir or the system is filled using mains water pressure. The fluid moves through a pressure regulator which limits the pressure to 12-15 lbs and then through a pressure relief valve that will limit the system pressure to 30 lbs. The fluid continues through an air scoop that removes air from the fluid by means of an air vent and into a circulating pump to the heat collector. As the system pressure increases to the desired pressure, air is expelled through the air vents located near the high point of the system as well as at the storage tank. The delta T controller causes the circulating pump to move the heat transfer fluid based on the operator controlled delta T settings. If the temperature meets the set points for an undesired temperature the control disconnects power causing a valve to open and drain the system. The power is also disconnected to the pressure pump, delta T control and the circulation pump. If a sensor is short or open circuited the electricity is automatically disconnected by the control. When the problem is corrected the system will re start. If a circulating pump fails then the collector temperature will rise to the set point and drain down before excess temperatures occur, preventing damage to the system components. The heat collection system will remain drained if the temperature on the collector or other sensing point is not within the given set point because the system has caused the electricity to be interrupted. The pressure pump and delta T controller

operating the circulating pump will have no electricity. When the temperature returns to the desired temperature programmed into the control or set by the operator based on safe temperatures recommended for the system design, the system will start. No operator assistance is required.

Brief description of the drawings

CETT (E) is the drawing showing the wiring diagram for one system

CETT (P) is the drawing showing the plumbing diagram for one system

Key Guide is the list of alpha numeric codes used in drawings CETT (E) and CETT (P) to identify the composition.

Copperhill™ 32 Key Guide
Copperhill Alternate Energy Inc.
Guide to Copperhill evacuated tube system setup

For authorized Copperhill use only.

The following notes are to be used along with diagram

Copperhill™ 32 plumbing diagram “CETT (P)”

Copperhill™ 32 electrical diagram “CETT (E)”

Letters refer to electrical systems and **numbers** refer to the closed loop heat transfer fluid system.

- A) 15 amp fuse
- B) 120V power supply 14/2 on a dedicated line to supply two pumps, two temp. controls, two 24V transformers and a solenoid valve.
- C) Power switch
- D) 24Vac transformer to power temperature sensing control and relay.
- E) Relay with temperature sensing control
- F) Thermistor on collector
- G) 24Vac transformer to power solenoid valve.
- H) Solenoid valve
- I) Not used
- J) Differential controller
- K) Thermistor from hot side of solar storage tank to differential controller
- L) Thermistor from hot side of solar collector to differential controller
- M) Circulating pump.
- N) Connection to charge pump.

- 1) Reservoir for heat transfer fluid
- 2) Pump to pressurize system
- 3) ½" ball valve
- 4) Pressure control
- 5) Relief valve
- 6) Pressure gauge
- 7) Screen
- 8) Air vent
- 9) Air scoop
- 10) Expansion tank
- 11) Circulating pump
- 12) Pressure gauge
- 13) Supply line
- 14) Solar collector
- 15) Air vent
- 16) Bellows connectors on hot and cold sides
- 17) Return line to heat exchange tank from solar collector.
- 18) Air vent
- 19) Domestic water supply
- 20) Heat exchange tank
- 21) Heat transfer fluid drain valve
- 22) Return line from exchanger to circulating pump line.
- 23) Domestic water heater (existing at customers. Various makes)
- 24) Heat transfer fluid
- 25) Ball valve
- 26) Solenoid valve
- 27) Drain line to reservoir.
- 28) Drain line from pressure relief

Patent application

Fluid heating “operating control and / or protection system”

Claims

- 1) A method of regulating temperature in a heat collector system with one configuration shown in drawing CETT (E), CETT (P) and accompanied by the “Key Guide”.

Where it is desired to control the temperature of the heat transfer fluid in a heat collector such as a solar thermal collector, a temperature sensor (F) attached to the heat source will report to a controller (E) capable of disconnecting electricity from the operating system. This control will disconnect electricity when the temperature is outside of programmed settings. This causes the pumps (M, N) to stop running and the system to drain via the normally open solenoid valve(H). The system plumbing is sloped to allow it to gravity drain. The system can be wired in any voltage or combination thereof. In one embodiment, 120V electricity (B) is wired to a main switch (C) and a 24V transformer(D) . A controller(E) that can disconnect 120V is installed. The 24V side of this controller is wired to the first transformer(D). The line (black wire) is then wired to the relay on the controller and back to a junction box where it is connected to a receptacle. The ground wire is also connected to the junction box and the receptacle. The neutral (white wire) is connected to the receptacle. The charge pump (N) and controller (J) are plugged in to this receptacle. A second 24V transformer (G) is attached to the junction box and wired to the same receptacle. A normally open 24V solenoid valve (H) is wired to the 24V side of this second transformer. The controller temperature sensor (F) is attached to the heat collector. After installation of the heat collection system and with the controller programmed to the desired limits, power can be applied. If the temperature reading is within the desired limits, the controller relay (E) will connect the electricity causing the receptacle to become live, powering the charge pump (N) and delta T controller (J) which also operates the circulation pump (M). The second transformer (G) is also powered up and causes the normally open solenoid valve (H) to close. If the temperature is outside of the safety zone the system will not start until the temperatures meet the safe zone.

- 2) The system in claim 1 where the system temperature is regulated by the operator set control temperature in conjunction with the sensor on the collector to prevent the system from exceeding a desired temperature that would cause system overheating
- 3) The system in claim 1 where the system temperature is regulated by the control temperature reading in conjunction with the sensor on the collector to prevent the system from exceeding a low temperature that would cause system freezing or temperatures lower than desired.
- 4) The system in claim 1 where a Sensor open circuit however caused will cause the system to shut down as described in claim 1

- 5) The system in claim 1 where a Sensor short circuit however caused will cause the system to shut down as described in claim 1.
- 6) The system in claim 1 where a power failure will cause the system to shut down as described in claim 1.
- 7) In the event of a circulating pump failure the system will shut down as described in claim 1.
- 8) The system in claim 1 where anti freeze burning due to excess temperatures is eliminated except for residue left on the walls of the collector to the extent that it has no material effect on the life of the antifreeze in it's normal life span.
- 9) The system as in claim 1 where a sensor placed on the storage and connected to a control can be operator programmed to automatically divert heat away from the storage via zone valves when the storage reaches a set temperature
- 10) The system in claim 1 where the system can be plumbed in using pex pipe, copper tubing, piping or system material as the control system allows the operator to set it below the maximum pipe, tube or system limit.
- 11) Any heat transfer fluid can be used as the system temperature is fully controlled by the set point and can be caused to drain before damage occurs.
- 12) The system as in claim one where the storage temperature can be controlled by the system settings.

Drawing CETT (P)

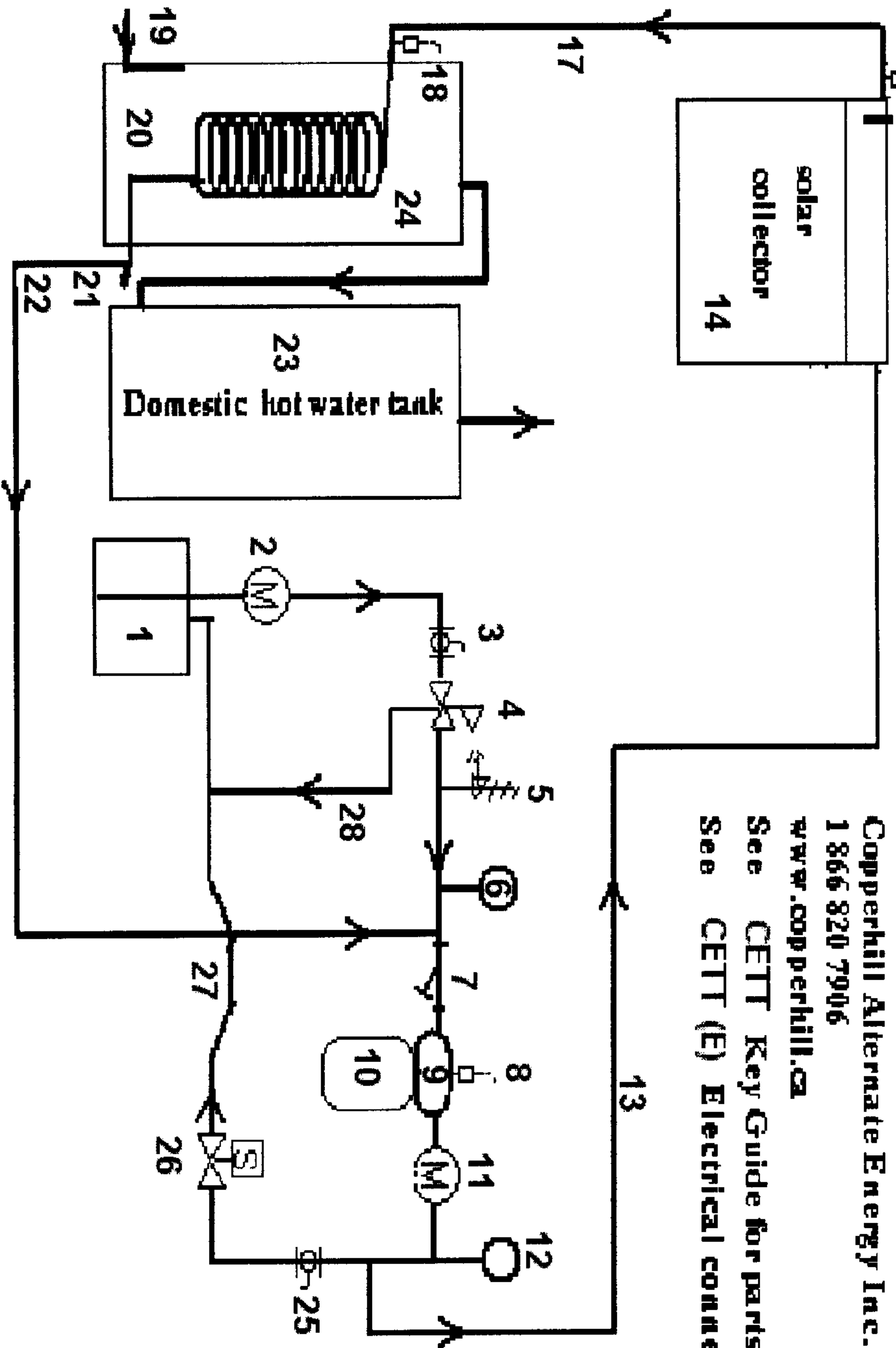

Copperhill (TM) 32 Plumbing installation
 Copperhill Alternate Energy Inc.
 1 866 820 7906
www.copperhill.ca
 See CETT Key Guide for parts list
 See CETT (E) Electrical connections

Drawing CETT (E)

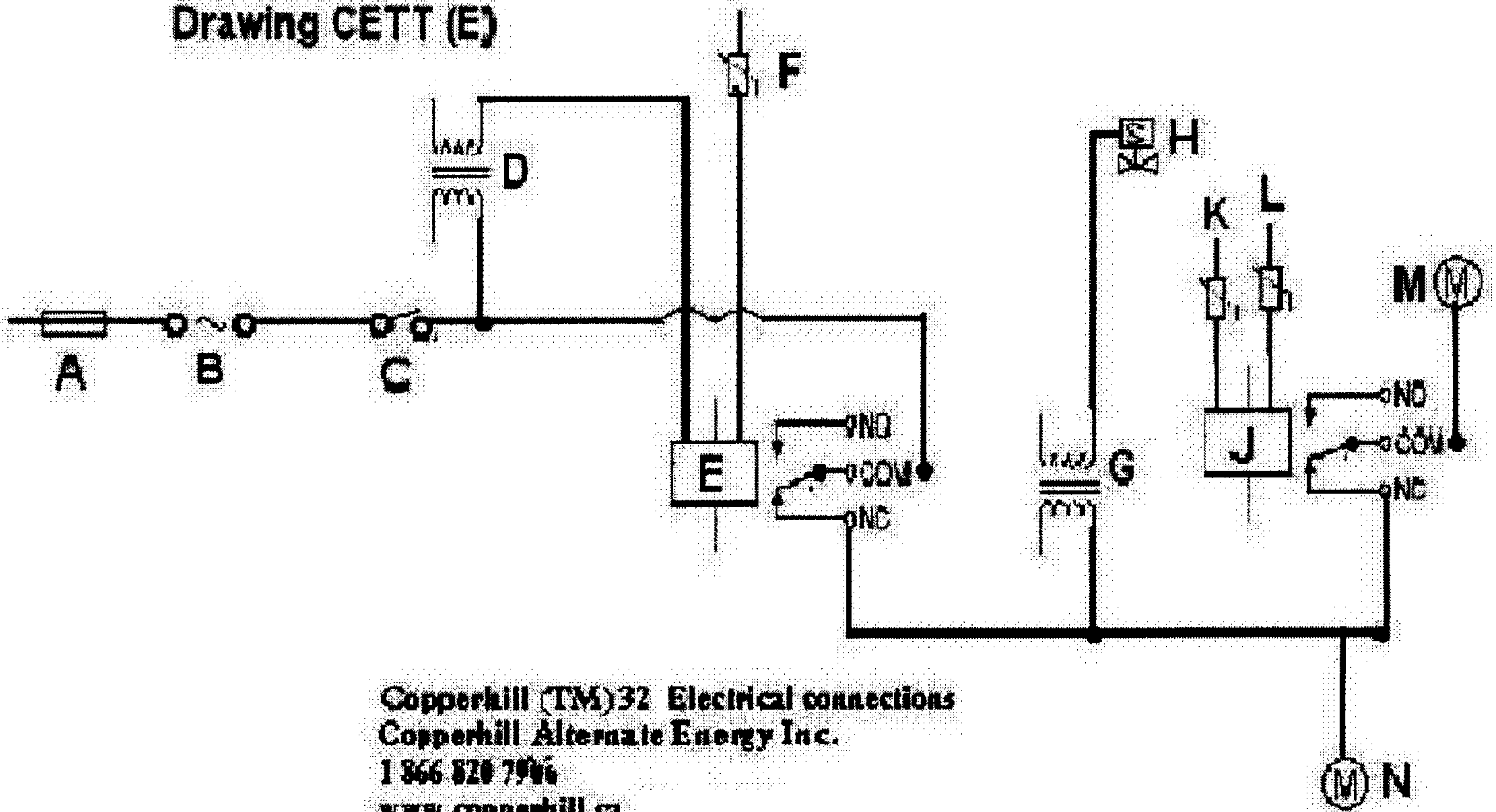

Copperhill (TM) 32 Electrical connections
Copperhill Alternate Energy Inc.
1 866 828 7996
www.copperhill.ca

See Copperhill (TM) 32 Plumbing installation
See "Copperhill (TM) 32 Key Guide" for parts list