

(No Model.)

5 Sheets—Sheet 1.

J. W. DEUBNER.
TIME RECORDER.

No. 603,320.

Patented May 3, 1898.

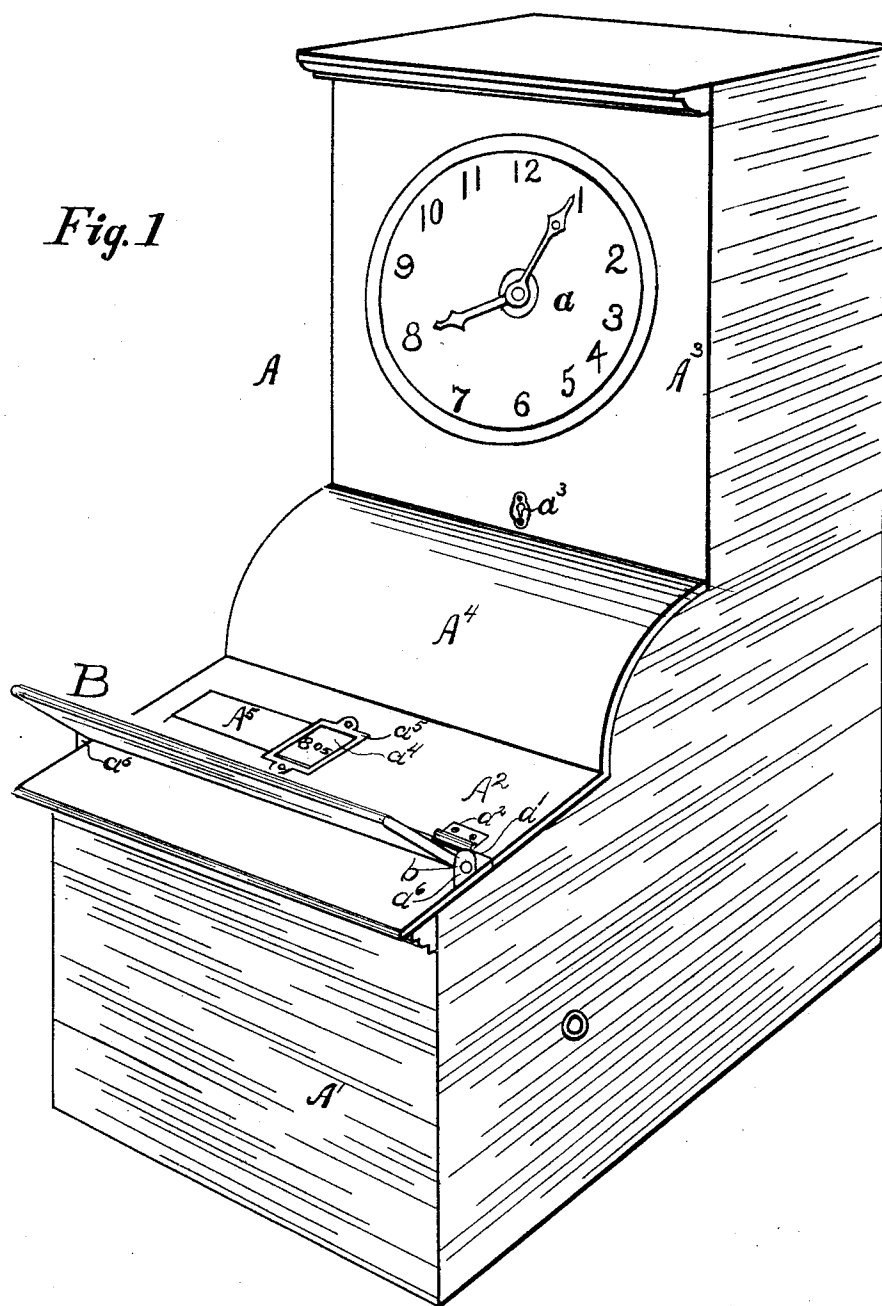

WITNESSES:

Glenn S. Noble.
D. M. Miller.

INVENTOR

John W. Deubner.

BY

Carter & Graves,

ATTORNEYS.

J. W. DEUBNER.
TIME RECORDER.

No. 603,320.

Patented May 3, 1898.

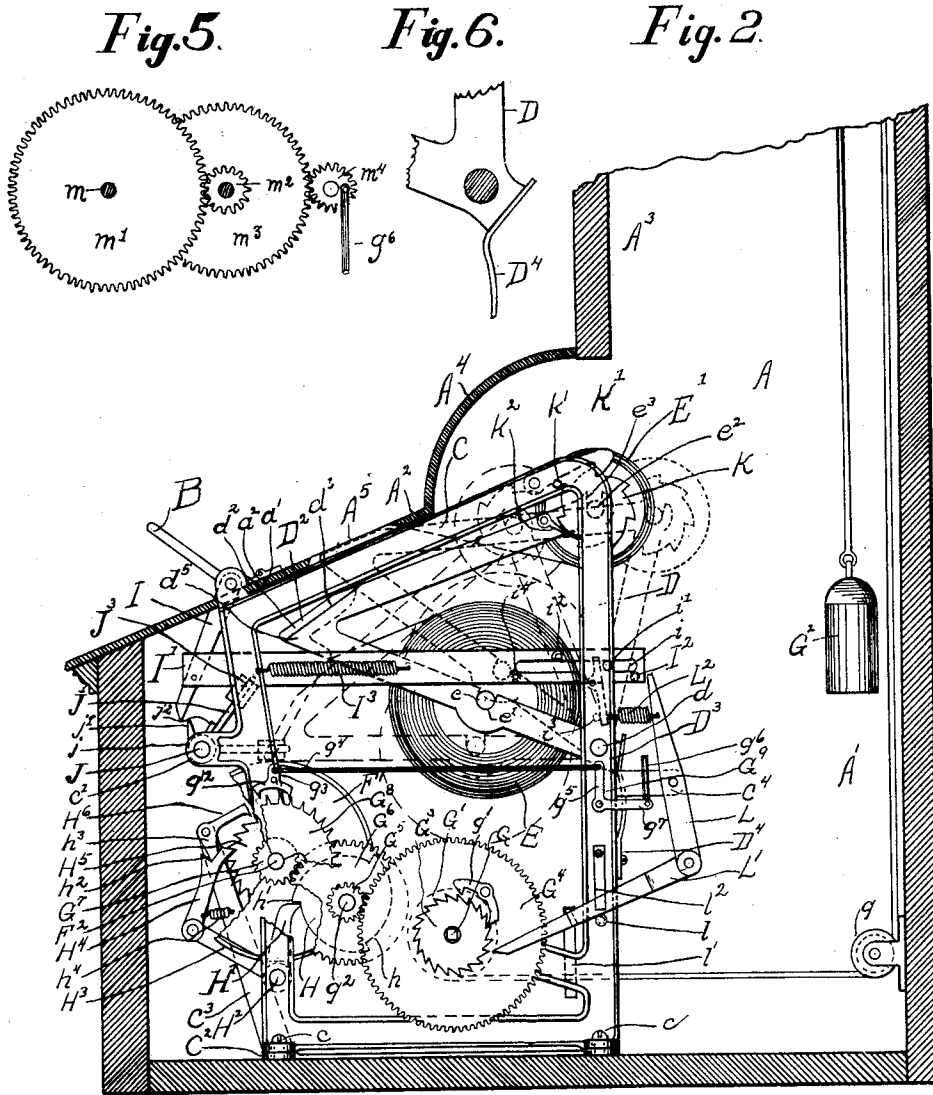

WITNESSES:

Glenn S. Noble.
D. M. Miller.

INVENTOR

John W. Deubner.

BY

Cartter & Howe.

ATTORNEYS.

J. W. DEUBNER.
TIME RECORDER.

No. 603,320.

Patented May 3, 1898.

Fig. 4

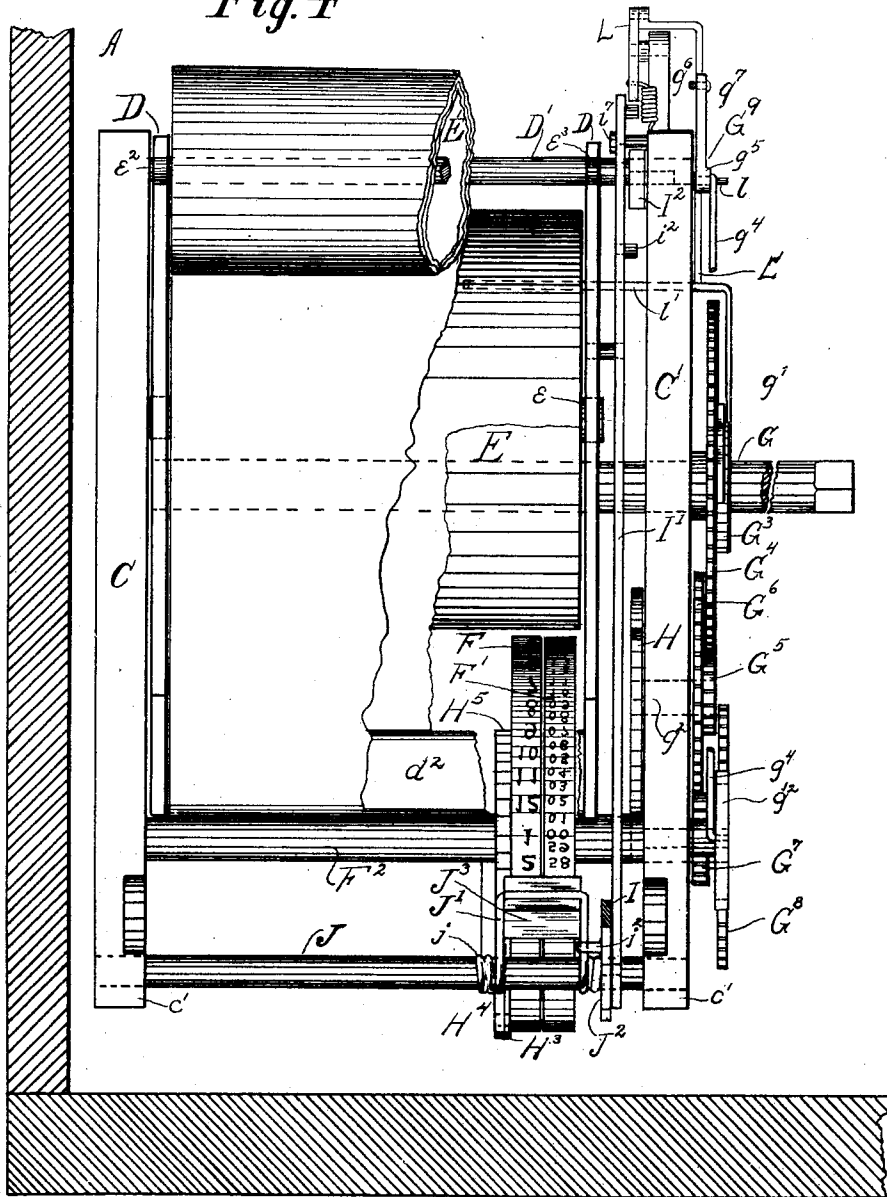

WITNESSES:

Glenn S. Noble.
D. W. Miller

INVENTOR

John W. Deubner.

BY

Carter & Snow,

ATTORNEYS.

J. W. DEUBNER.
TIME RECORDER.

No. 603,320.

Patented May 3, 1898.

FIG. 7.

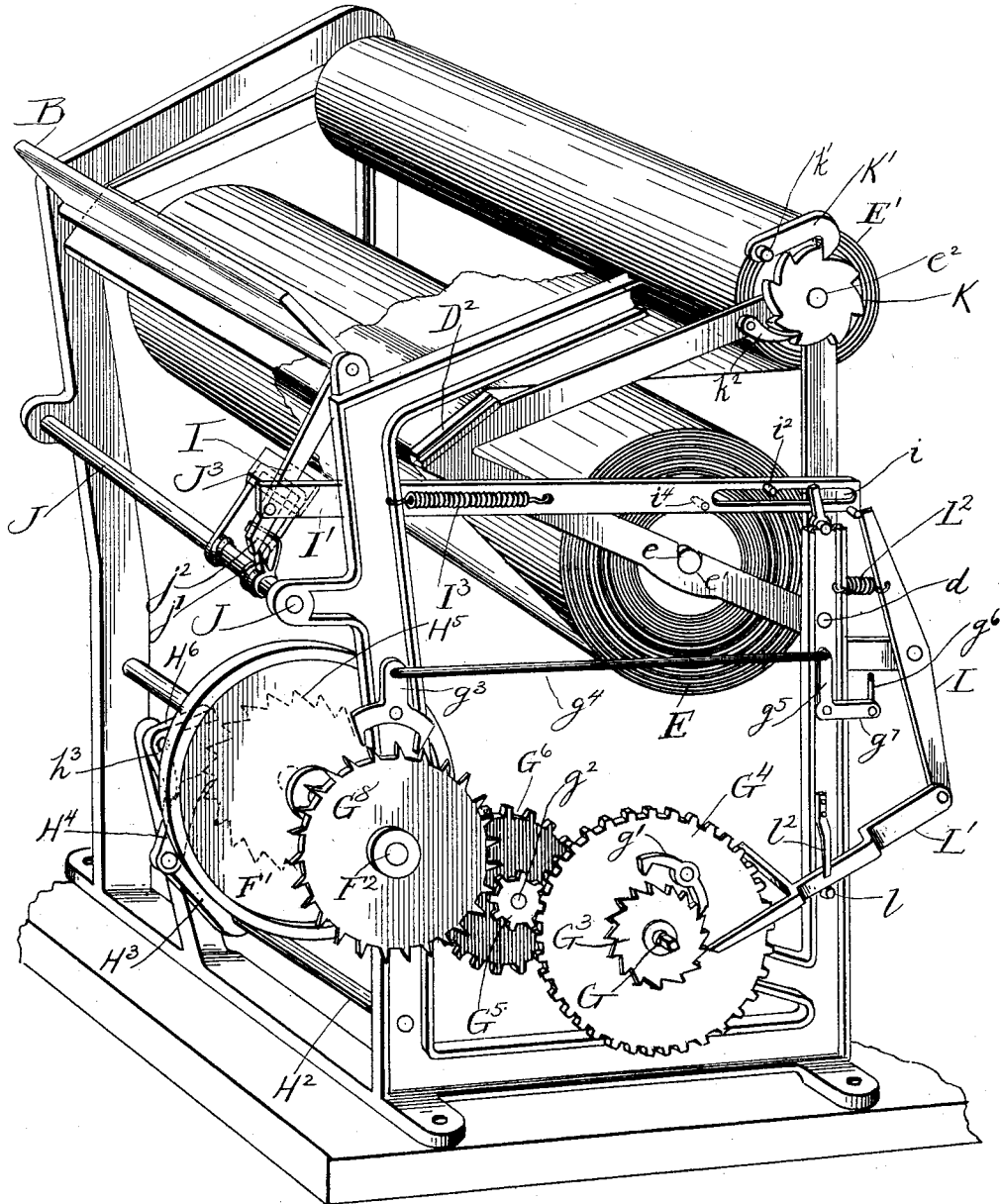

Witnesses:
J. Halpermy
D. P. Coody

Inventor:
John W. Deubner
 By *Carter & Crane,*
 Atty's.

UNITED STATES PATENT OFFICE.

JOHN W. DEUBNER, OF CHICAGO, ILLINOIS, ASSIGNOR, BY DIRECT AND MESNE ASSIGNMENTS, TO THE CHICAGO TIME REGISTER COMPANY, OF SAME PLACE.

TIME-RECORDER.

SPECIFICATION forming part of Letters Patent No. 608,320, dated May 3, 1898.

Application filed March 8, 1897. Serial No. 626,429. (No model.)

To all whom it may concern:

Be it known that I, JOHN W. DEUBNER, of Chicago, in the county of Cook and State of Illinois, have invented certain new and useful Improvements in Time-Recorders, of which the following is a specification.

This invention relates to improvements in time-recorders for recording the time of workmen and analogous uses, and refers more specifically to the improvements in machines of that class in which the workman is required to sign his name or make other identifying-marks upon a recording sheet or strip each time he registers "in" or "out," and therefore familiarly known as "autograph" machines. Machines of this type commonly embrace a clock mechanism, a printing mechanism controlled or operated by said clock mechanism, a recording sheet or strip, and mechanism for moving the sheet or strip to bring the latter into position for signature either at or immediately before or after the time is printed thereon, and in these several respects my present invention is no exception. In all previous machines with which I am acquainted, however, the part of the recording sheet or strip upon which the recorded time is printed has not only been made inaccessible to the workman while he is placing his signature or other mark upon the exposed part thereof in order to preclude any possible tampering with the printed record, but has also been concealed from his view, so that practically he has been compelled to sign in blank—that is to say, he is compelled to affix his signature to, and thus tacitly verify, a date or recorded time which he has not seen and cannot see at the time of signing nor immediately afterward. This would in itself perhaps not be seriously objectionable were it always a certainty that the machine would remain in perfect working order and could not be so changed or tampered with as to by any possibility present a false or erroneous record opposite the point signed or to be signed; but inasmuch as experience has shown that time-recording mechanisms are subject to disarrangement or wrong adjustment there is always more or less distrust and objection by the workmen who are thus unable to know

or verify the record they have made upon the recording-sheet.

It is a principal object of the present invention, therefore, to provide a machine of such construction that the portion of the recording-strip upon which the recorded time is printed and adjacent to which the signature or other identifying-mark of the workman is affixed shall be visible to the workman or readily subject to his inspection at or substantially at the time of making his signature or other identifying-mark thereon, so that he may know to a certainty exactly what he has or is about to verify, and therefore the exact amount of time he will be entitled to receive credit for.

The invention also has in view the production of a machine adapted to carry out the foregoing idea of generally simplified and improved construction, as will appear more fully from the detailed description thereof.

The invention consists in the matters hereinafter described, and particularly pointed out in the appended claims, and the same will be more readily understood by reference to the accompanying drawings, in which—

Figure 1 is a perspective view showing the outward appearance of a machine constituting a preferred embodiment of the invention. Fig. 2 is a longitudinal vertical sectional view taken through the casing and showing the principal part of the mechanism in side elevation, parts of the latter being broken away to better expose the construction of parts behind and the upper part of the machine being broken off to reduce the size of the figure. Fig. 3 is a view, partly in front elevation and partly in transverse vertical section, on an enlarged scale, the operative mechanism being shown in front elevation and the upper part of the machine being omitted in this case also. Fig. 4 is a sectional view showing the principal mechanism in plan view, said section being taken on a line parallel with and immediately beneath the inclined lid forming the writing-table of the casing and the rear part of the machine being broken away. Fig. 5 is a detail of the train of gears of the clock mechanism which serve to transmit movement to the escapement whereby the recording-

100

wheels are controlled. Fig. 6 is a fragmentary detail of the lower angular portion of that one of the side frames of the carriage upon which the spring acts, showing the manner in which the spring is arranged to act thereon to hold the carriage in its normal position. Fig. 7 is a perspective view of the working parts of the machine with the casing removed.

While the machine illustrated and described herein constitutes a practical and preferred embodiment of the invention, yet it is to be distinctly understood that considered in its broadest aspect the invention is not limited to this particular construction, but may be embodied in various other practical forms, and the following specific description of details of construction is to be understood as in no sense narrowing the invention to such construction.

Referring to said drawings, A designates as a whole an outer casing, which may be of any suitable or usual design, for inclosing the operative mechanism of the machine, that herein shown consisting of a generally rectangular main part A', provided with an inclined top or lid portion A², forming a writing-table or arm-rest, an upright rectangular extension A³ at the rear of the main part, within which is contained a clock mechanism, and provided in its front side with an opening through which is exposed a dial a', upon which the time of day is indicated in the usual manner, and a parti-cylindric cover portion A⁴, occupying the angle between the main part and the upright extension. A part of the cover is made removable, so as to afford access to the interior of the casing, the inclined lid A² being to this end divided transversely, as indicated at a', and the upper part thereof, together with the parti-cylindric portion, hinged to the lower front portion by means of hinges a², so that it may be lifted up toward the front of the machine. In order to prevent unauthorized meddling with the machine, the cover is provided with a lock conveniently located within the upright extension and adapted to engage the upper edge of the cylindrical part A⁴ when the lid is closed and operable by means of a key inserted through a suitable keyhole, as indicated at a³.

The inclined table or arm-rest is provided with a slot or opening A⁵ of suitable length and width to permit a workman desiring to register to write therethrough upon a recording-sheet, which is brought to position beneath said slot, as will be hereinafter more fully described, and preferably a portion of one end of the slot will be covered with glass or other transparent medium, so that the workman may see a portion of the recording sheet or strip which is not accessible to him. Conveniently and as herein shown the glass cover a⁴ is set within a suitable metal frame a⁵, arranged to occupy and secured within one end of said slot. Immediately in front of said slot in convenient position for the op-

erator to rest the ball of his hand or wrist thereon while writing upon the recording-sheet is arranged a flat operating-bar B, which preferably, although not necessarily, extends across the entire width of the machine, said bar being provided at its lower margin, at each end thereof, with pivot-trunnions b, which engage upstanding ears a⁶ upon the casing. The normal position of said bar is inclined obliquely upward and forwardly, as indicated in Figs. 1 and 2; but the bar is capable of being depressed into or toward a horizontal position, and when thus oscillated upon its pivots serves to actuate mechanism within the casing, which will now be described.

C C' designate two parallel skeleton side frame members of approximately rectangular outline and the several bars of each of which are preferably of channeled construction in cross-section, as best shown in Fig. 2. These side frames are rigidly united and held in upright parallel relation by means of a horizontal bottom skeleton frame member C², which rests upon and is secured to the bottom wall of the casing by means of a plurality of screws c, the lower ends of the upright side frames being secured to said bottom frame conveniently and in the present instance by means of the same screws or bolts which serve to secure the bottom frame to the casing.

Between the side frames is pivotally hung a carriage-frame consisting of two parallel triangular side frame members D, rigidly united at their lower rear angles by means of a transverse rod or bar D', (see Fig. 4,) the ends of which form trunnions d, which engage suitable trunnion-apertures in the side frame members C C'. At their front angles said side frames of the carriage are secured rigidly together by means of a transverse bar D², provided with a flat upper surface d², which forms a writing-platen. Said platen-bar is united at its ends with the triangular side frames in any suitable manner and is of such width and arranged at such inclinations that when the front end of the carriage-frame is lifted up into the position indicated in the dotted lines in Fig. 2 said platen-bar will be brought into register with the writing-slot of the casing and will be raised therethrough flush with the upper surface of said writing-table, the end portions of the platen-bar which project beyond the ends of the slot being rabbeted or cut away, as indicated at d³, to permit the intervening part of the bar to thus enter the slot.

Within the carriage are mounted two transversely-arranged paper-rolls, a supply-roll E, mounted in the lower part of the carriage-frame, and the trunnions e of which engage suitable trunnion-recesses e' in the lower side bars of the triangular carriage-frame, and an upper receiving-roll E', mounted parallel with the supply-roll and above the latter, the trunnions e² of this latter roll being also arranged to engage suitable bearing-recesses e³, formed in the rear upper angles of the car-

riage-frame. When the rolls are in operative position in the carriage, the recording strip or sheet carried thereby extends from the upper side of the supply-roll forwardly
 5 beneath the platen-bar, the lower surface d^5 of which is flat and arranged in a plane substantially radial to the pivotal axis of the carriage, and thence up over the upper surface of the platen-bar and to the under side
 10 of the receiving-roll and around the latter, as indicated most clearly in Figs. 2 and 4.

To next describe the printing devices whereby each time the operating-bar B is depressed characters indicating the time of day
 15 are printed upon the recording-sheet, F designates an hour type-wheel, and F' a minute type-wheel arranged side by side upon a transverse shaft F², which has suitable bearing at its ends in the front upright bars of
 20 the side frames C C', said type-wheels being so located with relation to the front end of the oscillatory carriage that when the latter is depressed, so as to bring its lower side into an approximately horizontal position, as indicated in dotted lines in Fig. 2, the lower
 25 surface of the platen-bar and the recording-strip passing underneath the same will be brought into printing-contact with the type-wheels. The said type-wheels, as is usual
 30 with machines of this class, are provided the one with a circumferential series of characters or figures running from "1" to "12" and the other with a series of characters running from "0" to "59," inclusive.

Preferably and in the present instance the type characters upon the printing-wheels will be made of rubber, so as to render more uniform the impression upon the recording-sheet; but if a more durable construction be found
 40 desirable the characters upon the type-wheels may be formed of metal, and in this case the impressing-surface of the platen-bar will preferably be provided with a covering of rubber to uniform the impressions.

In order to actuate the type-wheels, so that the latter will be caused to move synchronously with the clock-movement and to present at the printing-point the proper characters to indicate the correct time of day, mechanism is provided as follows: G designates a
 50 driven shaft mounted in suitable bearings in the side frame members, so as to extend transversely of the machine and parallel with the axis of the type-wheels, which shaft may be acted upon or driven by means of any suitable motor. As herein shown, the motive power consists of a winding-drum G', mounted concentrically upon the shaft G and provided with a cable which extends from the
 60 drum rearwardly to a guide-pulley g , mounted in the rear part of the casing, thence upwardly to the top of the casing and over a similar guide-pulley and carrying at its free end a weight G². One end of the main shaft G is arranged to extend outwardly through a
 65 suitable opening in the side of the outer casing and is conformed to receive a winding-

key, whereby the drum may be rotated to wind up the weight. Upon the shaft, externally to the side frame member C', is rigidly mounted
 70 a ratchet-wheel G³, and adjacent to said ratchet-wheel is loosely mounted a gear-wheel G⁴, which carries a pivoted pawl g' , adapted to engage the ratchet-wheel when the latter is acted upon by the motor. The gear-wheel
 75 G⁴ is arranged to intermesh with an idle-gear G⁵, mounted upon a stub-shaft g^{12} , which extends through the side frame member, and said shaft is also provided adjacent to the gear G⁵ with a larger gear G⁶, secured rigidly
 80 thereon and which in turn meshes with a pinion G⁷, rigidly mounted upon the end of the shaft F², which carries the type-wheel. The minute type-wheel is mounted rigidly upon the shaft F², and in order to control the movement of said shaft so that the minute-wheel will be caused to move forward a step at the end of each minute an escapement mechanism is provided consisting of an escapement-wheel G⁸, which is secured rigidly upon the
 90 type-wheel shaft adjacent to the gear-wheel G⁷ and is acted upon by an oscillatory pawl g^2 , pivoted adjacent to the periphery of said escapement-wheel upon the side of the frame member C'. Said pawl is provided with an
 95 upstanding arm g^3 , with the upper end of which is connected a rod g^4 , which extends rearwardly to and is connected with the arm g^5 of a bell-crank lever G⁹, pivoted upon the side of the rear upright of the side frame. A
 100 second actuating-rod g^6 is connected with the other arm g^7 of the bell-crank lever and leads thence vertically upward to the clock mechanism located in the upper part of the case and which will be hereinafter more fully described. The oscillatory escapement-pawl is provided with two acting ends and is so constructed as to permit the escapement-wheel to turn the distance of a half-tooth for each movement of the pawl, so that the escapement-wheel will have but thirty teeth or one-half as many as there are minutes in an hour.

The hour-wheel is mounted loosely upon the shaft F², and in order to move said wheel forward a step at the end of each hour mechanism is provided as follows: H designates a
 115 cam-wheel mounted rigidly upon the stub-shaft g^{12} and provided with as many equally-spaced spirally-arranged cam-surfaces h and corresponding radially-arranged drops h' as the type-wheel shaft turns for each revolution of said shaft g^{12} , in the present instance three, so that each time the minute-wheel performs one complete revolution the cam-wheel will be rotated from one cam-surface
 125 to the next.

H' designates a wiper arranged to act upon the cam-wheel, said wiper being mounted rigidly upon a rock-shaft H², which is mounted in suitable bearings to extend parallel with
 130 the shaft F² at a point immediately below the periphery of the type-wheels. The rock-shaft is provided with a rigid arm H³, arranged to project obliquely forward and upwardly and

carrying at its free end a pawl H^4 , which is adapted to act upon a ratchet-wheel H^5 , secured concentrically to the hour-wheel, the arrangement being such that each time the wiper is oscillated by the cam-wheel the pawl will move the hour-wheel forward a step.

In order to hold the hour-wheel in accurate printing-register while the pawl is being gradually retracted by the wiper, an L-shaped detent H^6 is provided, which is pivotally mounted upon the upper end of an arm C^3 , which projects from the bottom frame member C^2 upwardly adjacent to the pawl H^4 . Said pawl H^4 is provided with a shoulder h^2 adjacent to its acting end, which is adapted to engage the depending arm h^3 of the detent in such manner as to lift said detent out of engagement with the ratchet-wheel, when the pawl is thrust forward to turn the hour-wheel and to permit the detent to fall by gravity and engage the ratchet-wheel to prevent the hour-wheel from moving backward when the pawl is retracted. The shape of the acting end of the push-pawl is such that the dropping of the detent into engagement with the ratchet-wheel is rendered positive by reason of its action upon the depending arm of the latter. In order to hold the pawl in yielding engagement with the ratchet-wheel a spiral contractile spring h^4 is attached to the lower portion thereof and extends thence to and is connected with the arm C^3 .

Next describing the mechanism and connections whereby the types are first inked, the carriage next oscillated downwardly to carry the recording-sheet into contact with the type-wheels and take an impression therefrom, and thereafter oscillated upwardly into position to permit the workman to place his signature or identifying-mark thereon each time the operating-bar is depressed in the manner hereinbefore described, I designates an arm or lever connected rigidly with the operating-bar and arranged to depend downwardly within the casing, as best shown in Fig. 2.

J designates a rod arranged to extend transversely and having bearing at its ends in forwardly-projecting ears c' , formed in the side frames $C C'$, said rod being secured against rotation in its bearings. Upon the rod is mounted an inking device, which consists in the present instance of a wire loop J' of approximately rectangular form, the ends of which are formed into spring-coils $j j$, which encircle the rod J, and the extreme ends of which are inserted through suitable apertures in the rod or otherwise secured against rotation thereon. At a point upon the rod J in vertical alinement with the depending arm I is loosely mounted a tappet-block J^2 , provided with an upstanding arm j' , which is adapted to be engaged by the depending arm I, and a second arm or projection j^2 , which is connected with one of the sides of the loop J' . The outer free end of the loop carries an inking-pad J^3 , and the arrangement of the parts

described is such that as the arm I is oscillated it will first depress the spring-loop, so as to carry the inking-pad into contact with the type-wheels, and thereafter pass by the end of the upstanding arm and permit the inking-pad to spring back out of the way of the carriage which is about to descend. Upon the return movement of the depending arm the lower end of the latter will slip over the end of the arm j' into position to engage the same upon a subsequent movement.

I' designates a shift-bar arranged to extend horizontally between the inner side of the side frame member C' and the proximate side of the triangular carriage-frame member, the forward end of said bar being pivotally connected with the depending arm I, while the opposite end is provided with a longitudinal slot i , which engages and slides upon a stud i' , mounted upon and projecting inwardly from the rear upright of the side frame. Upon the shift-bar, toward the rear end thereof, is mounted a stud i^2 , which is adapted to engage an oscillatory lever I^2 , pivotally mounted between its ends upon the side frame, so as to stand approximately in a vertical position. The lower end of said oscillatory lever is arranged to act upon a stud i^3 , mounted upon the vertical bar of the triangular carriage-frame in such manner as to depress the carriage as the shift-bar is carried rearwardly. Said parts are so arranged with relation to each other that at the moment the carriage is carried into bearing with the type-wheels the stud i^2 will pass by the upper end of the oscillatory lever. A further movement of the shift-bar brings a second stud i^1 , mounted thereon, into engagement with the front side of the rear upright bar of the triangular carriage-frame, and thus in the continued movement of the shift-bar lifts the carriage up into position to receive the autograph, as indicated in dotted lines in Fig. 4, in which position the carriage will be held during the time the workman is making his record. In order to return the carriage to its normal position or that shown in full lines in the drawings, one of the triangular side frames thereof—in this instance the one remote from the observer—is provided with a downward extension D^3 at the lower angle thereof, which extension is acted upon by a flat plate-spring D^4 , secured upon the upright side frame, the arrangement being such that said spring tends to return the carriage to its normal position whichever way it be oscillated. In order to return the shift-bar and the connected parts to their normal positions, a coiled contractile spring I^3 is connected at one end with the front upright bar of the side frame C' and at its opposite end with a stud upon said shift-bar in rear thereof.

The arrangement of the paper-feeding mechanism is such that after the carriage has been tilted downward into position to form an impression upon the recording-sheet the paper is drawn forward as the carriage is re-

turned to the writing position, so as to bring that part of the recording-sheet transversely opposite the record just made thereon into register with the writing-slot, so that the workman may sign directly opposite the printed record. To this end a ratchet-wheel K is mounted rigidly upon the shaft of the receiving-roll adjacent to the frame member C', and a pawl K' is pivotally mounted upon said frame member in such position as to engage with said ratchet-wheel and rotate the receiving-roll one notch during that part of the movement of the carriage when it is being carried backwardly from its normal position into the writing position. Inasmuch as the carriage is tilted forwardly beyond that position in which the pawl has operative engagement with the ratchet-wheel, said pawl is provided with a laterally-inturned acting end *l*, (see Fig. 3,) and the ratchet-wheel is located out of alinement with the main body of said pawl, so as to permit it to pass by the latter. In order to hold the said pawl in operative position ready to reengage the ratchet-wheel upon the return movement of the carriage, a stud *l'* is provided upon the side frame adapted to support the pawl in proper position, and in order to hold the receiving-roll from turning backwardly a spring-pressed detent K² is mounted upon the side frame of the carriage and arranged to engage the ratchet-wheel at its free end, as indicated clearly in Fig 2.

It will be obvious that inasmuch as the height of the rear part of the casing within which the weight G² travels is considerable and the movement of the drum driven thereby is comparatively small for each clock movement mechanism the machine will run for a considerable period of time for each winding up of the drum; but as an auxiliary improvement which may or may not be adopted, as found most desirable, I have provided a self-winding attachment constructed and arranged as follows: L designates a lever pivoted between its ends upon a bracket C⁴, arranged to project rearwardly from the side frame member C', the upper end of said lever being arranged to project into the path of the shift-bar, so as to be oscillated by engagement of the end of the latter therewith each time the shift-bar is operated. Upon the lower end of said lever is pivotally mounted a push-pawl L', which extends obliquely forward and downwardly into position to engage the ratchet-wheel G³ of the motor-shaft, said pawl being held in proper operative position by means of a stud *l*, projecting laterally from the side frame member. The pawl is held normally retractive by means of a contractile spring L², connected at one end with the oscillatory lever and at its opposite end with a part of the frame. The width of the ratchet-wheel G³ is sufficient to permit the pawl to act thereon without interfering with the driving-pawl *g'* of the gear G⁴, as best shown in plan, Fig. 4, and in order that said push-pawl

may be thrown out of operative engagement with the ratchet-wheel when the machine has been wound to a desired limit the push-pawl is somewhat loosely pivoted to the lower end of the oscillatory lever, so as to permit a lateral movement of the free end of the pawl, and an arm *l'* is connected rigidly with the latter at a point between its ends and arranged to extend first horizontally inward to a position in vertical alinement with the position assumed by the horizontal part of the cable, which extends from the drum to the lower guide-pulley when the cable is wound to the desired extent, and is then deflected downwardly at right angles in position to be engaged at its lower end by said cable. The result of this construction is that when the weight has been wound up to a desired limit a further lateral movement of the cable due to its travel endwise upon the drum as the latter is wound full will engage the depending end of the arm *l'* and thrust the push-pawl out of alinement with the ratchet-wheel, so that it will no longer act thereon. In order to return the pawl into position to act upon the ratchet when permitted by the unwinding of the cable, a flat spring *l*² is secured upon the side frame adjacent to said push-pawl and arranged to bear upon the outer surface of the latter with its free end, so as to tend to hold it in operative position.

The connection with the clock by means of which the escapement is operated to permit the minute-wheel to turn forward a step at the end of each minute may be of any desired or preferred construction, a practical and convenient arrangement being that shown in detail, Fig. 5, wherein *m* designates the minute-hand shaft of an ordinary clock-movement, *m'* a gear mounted rigidly thereon, and *m*² a pinion arranged to mesh with the gear and connected with a second gear *m*³, which in turn meshes with a pinion or pitman wheel *m*⁴. The vertically-extending connecting-rod *g*⁶ hereinbefore described is connected at its upper end with the pitman-wheel *m*⁴ by means of a suitable wrist, and the relative sizes of the several members of the train of gears thus described is such that the pitman-wheel will perform a half-revolution each minute, and thus through the medium of the bell-crank lever operate the escapement properly.

The operation of the machine will be readily understood from the foregoing description and need not therefore be set forth in detail.

While the machine herein described is so constructed as to expose the printed record upon the recording-sheet during the time said sheet remains in position to receive the signature thereon and is deemed a preferred construction, yet it will be obvious that an operative form of machine might be devised in which the printed record would be exposed in a different manner from that herein described without departing from the spirit of the invention.

I claim as my invention--

1. In a time-recorder, the combination with the casing and the clock-controlled printing mechanism and recording-sheet therein, of means operable from without the casing for taking an impression from the printing mechanism, means enabling the individual effecting the impression to attach his identification-mark thereto, and a sight-opening through which the said impression may be viewed, whereby the individual is enabled to inspect for identification the record to which he attaches his identification-mark.

2. In a time-recorder, the combination of a casing, a clock-controlled printing mechanism, a normally stationary recording sheet or strip therein, and means for feeding the sheet step by step, means operable from without the casing for effecting the printing of a time-record, means enabling the individual making the time-record to mark the same for identification, and a sight-opening through which the time-record may be viewed, whereby the individual is enabled to inspect for identification the record to which he attaches his identification-mark.

3. In an autograph time-recorder, the combination of a casing clock-controlled time-printing mechanism and a recording-sheet within the casing, means operable from without the casing for effecting the printing of a record on the recording-sheet, a slot in the casing through which the sheet is exposed for signature and a sight-aperture through which the record may be viewed, whereby the individual is enabled to inspect for verification the record to which he attaches his identification-mark.

4. In an autograph time-recorder, the combination with a casing and a recording mechanism and time-recording sheet therein, of a slot in the casing through which the recording-sheet is exposed for signature and a transparency adjacent to said slot through which the printed record to which the signature is affixed, may be viewed when affixing the signature thereto.

5. In an autograph time-recorder, the combination with a casing, provided with a slot and clock-controlled printing mechanism embracing printing-forms arranged within the casing, of a carriage pivotally mounted within the casing, a platen upon said carriage, a recording-sheet carried by the carriage and arranged to pass over the platen thereof and means for swinging the carriage about its pivotal support, said printing-forms being arranged directly in the path of the platen so that the latter is brought into printing contact with said forms by the swinging of the carriage.

6. In an autograph time-recorder, the combination of a casing provided with a slot and clock-controlled printing mechanism arranged within the casing, a movable platen-carrying carriage, mounted within the casing, a recording-sheet arranged to pass over the

platen and adapted to be brought into position to receive a signature thereon through the slot and a sight-opening through which the printed record upon the recording-sheet may be inspected at the time of affixing the signature thereto.

7. In an autograph time-recorder, the combination of a casing clock-controlled printing mechanism and an oscillatory platen-carriage within the casing, a recording-sheet carried by said carriage, a slot within the casing through which the recording-sheet may be exposed for signature and means for oscillating the carriage to carry the recording-sheet into printing contact with the printing devices and to thereafter carry it into position to expose the recording-sheet through the slot.

8. In an autograph time-recorder, the combination of a casing clock-controlled printing mechanism, and an oscillatory platen-carriage within the casing, a recording-sheet carried by said carriage, a slot in the casing through which the recording-sheet may be exposed and means for oscillating the carriage to first carry the recording-sheet into printing contact with the printing devices and to thereafter return it to and beyond its normal position into position to expose the recording-sheet for signature to the slot.

9. In an autograph time-recorder, the combination of a casing, clock-controlled printing mechanism and an oscillatory platen-carriage within the casing, a recording-sheet carried by said carriage, a slot in the casing through which the sheet may be exposed and means for oscillating the carriage to first carry the recording-sheet into printing contact with the printing devices and to thereafter return it to and beyond its normal position into position to expose the recording-sheet for signature to the slot, said movement being effected by means of an oscillatory operating-bar arranged outside of the casing and suitable operative connections whereby both the forward and return movements of the carriage are caused by a single movement in one direction of said operating-bar.

10. In an autograph time-recorder, the combination of a casing, clock-controlled printing mechanism and an oscillatory platen-carriage within the casing, a recording-sheet carried by said carriage, a slot in the casing through which the sheet may be exposed means for oscillating the carriage to first carry the recording-sheet into printing contact with the printing devices and to thereafter return it to and beyond its normal position into position to expose the recording-sheet for signature to the slot, said movement being effected by means of an oscillatory operating-bar arranged outside of the casing and suitable operative connections whereby both the forward and return movements of the carriage are caused by a single movement in one direction of said operating-bar, and means operating to automatically return the carriage

to a position rendering the recording-sheet inaccessible through the slot.

11. The combination in a time-recorder having a casing provided with a slot through which the recording-sheet is adapted to be exposed and a printing mechanism and recording-sheet within the casing, of means for effecting the printing of a time-record and for bringing the sheet into position to receive a signature consisting of an operating-bar located outside the casing adjacent to the slot and arranged to normally stand in an upwardly-projecting position said operating-bar being adapted to accomplish the printing of a time-record upon the recording-sheet and the bringing of the latter into position to receive a signature with the time-record exposed to view when depressed into or toward a horizontal position by resting the hand thereon when in writing position.

12. In an autograph time-recorder the combination of a casing provided in its upper side with a slot, an oscillatory carriage mounted within the casing adjacent to said slot, provided with a platen-bar and an impressing-bar and carrying receiving and supply rolls, a recording-sheet upon said rolls arranged to pass over the impressing bar and platen in its passage from the supply to the receiving roll, minute and hour type-wheels rotatably mounted in the path of the impressing-bar, mechanism for rotating said type-wheels to cause them to present printing characters representing the time of day at the printing-point, an inking device adapted to cooperate with the type-wheels and means operable from without the casing for oscillating the carriage to cause an impression upon the recording-sheet and to bring the latter into position to receive his signature thereon.

13. In an autograph time-recorder, the combination of a casing provided in its upper side with a slot, an oscillatory carriage mounted within the casing adjacent to said slot and consisting of two parallel triangular-shaped side or end frames rigidly secured together and pivotally mounted upon an axis extending longitudinally of the carriage adjacent to one of the outer angles of the same, a combined impressing bar and platen extending between said side frames at one of the other angles of the carriage having its impressing-surface arranged in a plane substantially radial to the pivotal axis of the carriage, receiving and supply rolls upon the carriage, a recording-sheet mounted upon said roll arranged to pass over the impressing and platen bar in its passage from the supply to the receiving roll, minute and hour type-wheels rotatably mounted in the path of the impressing-bar, mechanism for actuating said type-wheels, an inking device adapted to cooperate with the type-wheels, and an operating-bar arranged outside the casing and provided with operative connections for oscillating the carriage to cause an impression upon the recording-sheet and to bring the platen into po-

sition to receive a signature upon the recording-sheet.

14. In an autograph time-recorder, the combination with a casing provided with a slot, through which the recording-sheet is adapted to be exposed, an oscillatory carriage provided with a platen and carrying supply and receiving rolls, a recording-sheet arranged to pass over said platen in its passage from the supply to the receiving rolls, mechanism for printing a time-record upon the sheet an automatic paper-feeding device adapted to feed the paper into position upon the platen to receive a signature thereon opposite the time-record as the platen is brought into register with the slot.

15. The combination in a time-recorder provided with printing-forms, of an inking device comprising an oscillatory arm carrying at its free end an inking-pad, a spring tending to hold said arm normally free from the type, a tappet-block mounted adjacent to the oscillatory arm and adapted to act upon the latter to depress the inking-pad into contact with the type and a radial arm upon the tappet-block arranged to project into the path of a reciprocatory part of the recorder mechanism, said reciprocatory part being adapted to oscillate the inking device into contact with the types and to thereafter permit it to spring back to its normal position.

16. In a time-recorder, the combination with a casing, provided with a slot and an oscillatory platen-carriage adapted to bring the recording-sheet into position to expose it through the slot, of means for actuating said carriage, comprising an oscillatory bar arranged outside the casing and provided with a rigid arm extending within the casing, a shift-bar pivotally connected with the arm at one end and having sliding support upon the machine-frame at its other end, a stud upon the shift-bar, an oscillatory lever pivoted between its ends upon the machine-frame and adapted to be engaged by the stud of the shift-bar, oscillated a limited distance thereby and released in the further movement of the bar, a stud upon the carriage-frame located in position to be engaged by the opposite end of the oscillatory lever to oscillate the carriage in one direction and a second stud upon the shift-bar adapted to directly engage the carriage-frame to oscillate it in an opposite direction, whereby the impressing movement and the returning of the platen-carriage into position to receive a signature upon the recording-sheet are effected by the movement in a single direction of the operating-bar.

17. In a time-recorder the combination with the recording mechanism, a motor for actuating the printing-forms, and an operating device arranged outside the casing for effecting the printing operation, of an automatic winding device, consisting of a ratchet-wheel arranged to act upon the winding-shaft of the motor, and a pawl arranged to act upon

the ratchet-wheel and operatively connected with the printing mechanism whereby the ratchet-wheel will be operated each time an impression is taken from the printing-forms.

5 18. In a time-recorder, the combination with the recording mechanism, a motor for actuating the printing-forms, and an operating device arranged outside the casing for effecting the printing operation, of an automatic winding device, consisting of a ratchet-wheel arranged to act upon the winding-shaft
10 of the motor, and a pawl arranged to act upon the ratchet-wheel and operatively connected with the printing mechanism whereby the

ratchet-wheel will be operated each time an impression is taken from the printing-forms, and means operating to automatically throw the self-winding mechanism out of operation when the motor has been wound up to a pre-determined limit. 15

In testimony that I claim the foregoing as my invention I affix my signature, in presence of two subscribing witnesses, this 6th day of March, A. D. 1897. 20

JOHN W. DEUBNER.

Witnesses:

ALBERT H. GRAVES,
HENRY W. CARTER.