



HU000033507T2

(19) **HU**(11) Lajstromszám: **E 033 507**(13) **T2****MAGYARORSZÁG**
Szellemi Tulajdon Nemzeti Hivatala**EURÓPAI SZABADALOM**
SZÖVEGÉNEK FORDÍTÁSA

(21) Magyar ügyszám: **E 13 171267** (51) Int. Cl.: **B65D 1/24** (2006.01)
(22) A bejelentés napja: **2009. 11. 17.** **B65D 85/30** (2006.01)
B65D 6/18 (2006.01)
(96) Az európai bejelentés bejelentési száma: **B65D 25/30** (2006.01)
EP 20090171267 **B65D 1/22** (2006.01)
(97) Az európai bejelentés közzétételi adatai: **B65D 6/16** (2006.01)
EP 2639170 A1 **2013. 09. 18.**
(97) Az európai szabadalom megadásának meghirdetési adatai:
EP 2639170 B1 **2016. 12. 21.**

(30) Elsőbbségi adatok: 16562009 2009. 10. 28. CH PCT/EP2009/007965 2009. 11. 06. WO	(73) Jogosult(ak): IFCO Systems GmbH, 82049 Pullach (DE)
(72) Feltalálók(k): Orgeldinger, Wolfgang, 81539 München (DE) Delbrouck, Klaus, 50825 Köln (DE)	(74) Képviselő: Danubia Szabadalmi és Jogi Iroda Kft., Budapest

(54) **Szállító- és bemutatóláda**

Az európai szabadalom ellen, megadásának az Európai Szabadalmi Közlönyben való meghirdetésétől számított kilenc hónapon belül, felszólalást lehet benyújtani az Európai Szabadalmi Hivatalnál. (Európai Szabadalmi Egyezmény 99. cikk(1))

A fordítást a szabadalmas az 1995. évi XXXIII. törvény 84/H. §-a szerint nyújtotta be. A fordítás tartalmi helyességét a Szellemi Tulajdon Nemzeti Hivatala nem vizsgálta.

TRANSPORT AND PRESENTATION BOXDescription

5 The present invention relates to boxes for transporting goods, allowing the goods transported in the box to be presented to a consumer and to ease access to the goods in the box for him or her.

 A plurality of products are transported in boxes open at the top. For example, a plurality of different box shapes are known in the beverage industry for transporting beverage bottles or smaller packs of beverage bottles (for example so-called "six-packs") from production to retail. In retail, the boxes are normally stacked, so that access can only be made from the top and hence products inside a box that is at a lower position in the stack can only be accessed when all the boxes above the same have been removed. This is extremely inconvenient and time and energy-consuming.

 Different boxes with foldable and stationary side walls of equal height are described, for example, in US 6,601,724 B1, EP 2 062 827 A1, EP 2 030 903 A1, EP 0 275 919 A2, EP 0 260 698 A1, DE 2 617 051 A1, EP 0 530 610 B1, DE 76 17 706 U1, DE 38 09 585 A1, DE 92 11 684 U1, DE 42 30 021 A1, DE 87 16 137 U1, DE 12 79 534 B or US 2006/016811 A1.

 Hence, it would be advantageous to provide boxes allowing products transported within the box to be accessed more efficiently and easily.

 It is the object of the present invention to provide an improved box allowing improved access to products in the box, yet in connection with secure accommodation of the goods in the box.

 This object is achieved by a box in accordance with claim 1.

 Thus, several embodiments of the present invention comprise a floor or bottom and at least two pairs of respectively opposing side walls, wherein a first one of the side walls is designed such that it allows removal of products contained in the box. For this purpose, the first side wall extends from the floor towards the top in a vertical direction at least partly by only a lower removal height that is lower than the height of one or several of the other side walls. The removal height is determined such that, from the first side wall, a lateral opening is defined having a dimension allowing access to or removal of products contained in the box through the lateral opening. The box is limited towards the top by the first side wall area extending from the floor towards the top (which can also be the whole side wall) having a lesser removal height in the vertical direction. This means that above this first side wall area there is no further force-fit connection between the adjacent side walls.

 In other words, the first side wall is at least partly less high than the surrounding or several of the surrounding side walls, so that, when the boxes are stacked, the box can also be accessed from the side in order to gain easy access to products that are in lower boxes of the stack.

 Thereby, in some embodiments, the height of the first side wall is still dimensioned such that the specific products transported in the box cannot fall out of the box during transport. In some embodiments, the box is intended for transporting bottles or bottles prepacked in small packs, which is why the first side wall has a height that is sufficient to prevent individual bottles from falling out of the box. In some embodiments, the

height is between 1 and 10 cm. In some further embodiments, this height is between 2 and 5 cm or generally more than 2 cm.

In some embodiments, the first side wall has, at its rims bordering on the adjacent side walls, two side wall portions each, extending up to the height of the adjacent side walls in order to increase the stability of the box.

In further embodiments of the present invention, the box has four side walls, wherein, at least in the side walls adjacent to the first side wall, grip openings are arranged. The grip openings have an area running parallel to the floor as well as an area running perpendicular to the floor. In some embodiments, the area running perpendicular to the floor is arranged in the direction of the first side wall. Additionally, in some embodiments, the first horizontal opening portion running essentially parallel to the floor merges into the vertical opening portion having a radius large enough to enable gripping the box also within the radius. Hence, in these embodiments of the present invention, it is possible to grip the box also within the radius or in the vertical opening portion and to lift the same such that it tilts backwards when gripped. This reduces the probability of things falling out during transport, such as bottles falling out of the box through the openings of the first side wall.

Further, in accordance with the invention, the box comprises, in the floor area adjacent to the first side wall, a larger supporting area for the products to be transported compared to the average in the other area of the floor. In other words, when the floor is not completely formed for weight-saving reasons, but consists, for example, of individual bars, this means that the number of bars per area, i.e. the bar density, is increased in the area adjacent to the first side wall. This has the effect that goods introduced into the box close to the side wall, for example a beverage bottle or can having a large supporting area is in contact with the floor. This prevents the bottle or beverage can from sliding or tilting into recesses between the floor bars, so that unintentional falling out of the can or the bottle during transport is avoided.

Further, in some embodiments, the side walls that are adjacent to the first side wall are less high at the front side where they border on the first side wall than at the front side opposing the side wall. This means that in the direction of the opening the side walls adjacent to the opening are lower, so that, on the one hand, the space available for removal is increased and, on the other hand, the incidence of light or the viewing angle into the inside of the box is increased in order to make it easier to see the goods, such as bottles or the like, transported within the box.

In some further embodiments, the other side walls not corresponding to the first side wall are foldable with respect to the floor, so that the box can be brought into a folded or collapsed state where the other side walls rest approximately parallel to the floor on the same or are above the floor. In this way, the box can be transported more cost-effectively and efficiently in the empty state.

Several embodiments have an additional movable side wall area extending in a vertical direction above the first side wall and which can either be detached or folded in. This can have the advantage that in the folded-out state the movable side wall area additionally increases the stability or the security so that no goods or products can fall out of the box. Further, in the folded-out or folded-in state, the movable side wall area can be used to present product information or the like.

In some embodiments, the movable side wall area is implemented in a grid shape or formed of a plurality of lands, so that the box can be cleaned by high-pressure blasting without separating the movable side wall area from the box or unintentionally releasing the same from the box due to the high pressure.

Further, in some embodiments, the other side walls are coated or laminated on the inside with a foil containing product information that is easily visible from the outside.

In some further embodiments, light-colored foil is provided so that the goods or bottles transported in the box can be better perceived optically by the light reflection.

In some further embodiments, the other three side walls not corresponding to the lower wall have the same height, so that the boxes can be stacked on top of one another, wherein the floor of one box comes to rest on the other three side walls of the box below it. For this purpose, both in the floor and in the upper ends of the other side walls, special recesses or contours can be provided into which the corresponding recesses or contours of the floor or the other side walls engage in order to allow stackability and to ensure a firm stance.

In some embodiments of inventive boxes suitable for storing or transporting and presenting beverage bottles or cans, the floor comprises a plurality of pintles or mandrels extending in a vertical direction from the floor towards the top. Mandrels are three-dimensional objects that are on the floor and are shaped such that the bottles are held or secured by the outer limiting areas of the mandrels, so that the bottles are effectively prevented from falling out. In some embodiments, the mandrels have only a low height in the vertical direction, so that the same can also be referred to as mandrel stubs. The height and outer shape of some mandrels is selected such that they prevent, in connection with the first side wall, the bottles from falling out through the lateral opening. In order to still ensure removal, in some embodiments the mandrels are, at their highest position, not higher than the first side wall. In some embodiments, the outer limiting areas of the mandrels have a varying height in order to adapt them as best as possible to the tasks in hand. In order to allow the bottles to tilt out in the direction of the first side wall and still ensure good stability, the mandrels have a lower height in a direction parallel to the side wall than in the direction towards the first side wall, so that tilting parallel to the first side wall is enabled, whereas tilting in a direction perpendicular thereto is hindered and the bottles are securely held.

Preferred embodiments of the present invention will be discussed below with reference to the accompanying drawings.

They show:

- 30 Fig. 1 an embodiment of a box for transporting bottles;
- Fig. 2 the embodiment of Fig. 1 loaded with "sixpacks";
- Fig. 3 filled, stacked boxes according to the embodiment of Fig. 1;
- Fig. 4 the embodiment of Fig. 1 in a bottom view;
- Fig. 5 a further embodiment of an inventive box;
- 35 Fig. 6 a further embodiment of an inventive box having foldable or collapsible side walls;
- Fig. 7 the embodiment of Fig. 5 in a partly folded state;
- Fig. 8 the embodiment of Fig. 6 in a completely folded state;
- Fig. 9 the embodiment of Fig. 6 filled with bottles;

Fig. 10 the embodiment of Fig. 6 filled with "sixpacks";

Fig. 11 a top view of the box of Fig. 6; and

Fig. 12 a detailed view of several mandrels used in some embodiments of the invention.

Fig. 1 shows an inventive embodiment of a box 10 for beverages. In the embodiment shown, the floor
 5 12 is not continuously formed in a plane but consists of a grid-like structure. As can be seen in the bottom view
 of the box of Fig. 3, the floor 12 is formed by a plurality of lands or bars. The same are arranged closely enough
 that the goods to be transported, i.e., for example, a bottle, cannot fall through the floor of the box or tilt in an
 uncontrolled manner when the edge of a bottle tilts into one of the cavities between the lands.

Further, the box comprises two pairs of respectively opposing side walls 14a, 14b and 16a, 16b
 10 extending from the floor 12 towards the top, i.e. in the vertical direction 18. A first one of the four side walls, in
 this example side wall 16b, extends merely by a lower removal height 20 into the vertical direction 18.

The removal height 20 is lower than the height of the other side walls 14a, 14b and 16a, so that a
 lateral opening is formed allowing access to or removal of bottles or products contained and transported in the
 box through the lateral opening. Above the first side wall 16b there is no further structure of the box. Further, on
 15 the floor 12 of the embodiment shown in Fig. 1, a plurality of mandrels are arranged, of which exemplarily the
 mandrel 22a and the mandrel 22b are emphasized. This means that the lateral opening for removing the products
 is generated by the fact that the first side wall 16b has a lower height than the adjacent or the other side walls.
 Here, as in the following figures, height means the dimension in the positive vertical direction 18. The term
 "top" relates to a position in the positive vertical direction 18, the term "bottom" to a position having a lower
 20 coordinate in the vertical direction 18. Sides are any directions limiting the box in the directions parallel to the
 surface of the floor 12.

The first side wall 16b defines or forms a lateral opening allowing access or removal of the bottles
 transported inside the box. In other embodiments, of course, other products can be transported in the box. In the
 box of Fig. 1, also so-called "sixpacks" can be transported, i.e. prepacked packs of six bottles.

25 In alternative embodiments not shown here, the side wall does not have the removal height 20 along
 its full length, but fixed side wall portions extend from the adjacent side walls 14a and 14b into the lateral
 opening, wherein the lateral opening still remains large enough for removal of the products to be ensured. Such
 boxes can have an increased stability.

The embodiment of a box 10 shown in Fig. 1 further comprises a movable side wall area 23 rotatably
 30 mounted with respect to a fixed first side wall 16b via hinges 24a to 24c. The movable side wall area 23 is
 shown in a folded-in position in Fig. 1, where the same is folded downwards with respect to the first side wall
 16b. In the folded-up position, which will be illustrated below using some further embodiments, the movable
 side wall area 23 extends towards the top in the vertical direction 18. Thereby, the security can be additionally
 increased such that bottles inside the box 10 do not tilt towards the outside. Additionally, the movable part can
 35 be used to present product information or the like.

The side walls 14a and 14b adjacent to the first side wall each comprise a grip opening 28a and 28b,
 where the box can be lifted and carried. Thereby, the grip openings include both a first opening area extending

parallel to the floor and a second opening area extending substantially in a vertical direction, the function of which will be discussed in more detail below with reference to Fig. 3.

Further, the side walls 14a and 14b adjacent to the first side wall 16b comprise, at the end pointing in the direction of the first side wall, beveled edge areas 30a and 30b through which light can enter the boxes even when the same are stacked one on top of the other. Thus, in the embodiment shown in Fig. 1, the ends of the side walls 14a and 14b adjacent to the first side wall 16b have a lower height than at their opposite end. It is obvious that, although in the embodiment shown in Fig. 1 the recess part of the side wall is essentially triangular, any other forms of the recess can also be used for alternative embodiments. In some embodiments, the height of the side walls 14a and 14b adjacent to the first side wall 16b continually rises up to the maximum height. In alternative embodiments, the increase in height can, of course, also be in steps or stages.

The box shown in Fig. 1 is stackable, i.e. the contours of the upper ends of the side walls 14a, 14b and 16a are designed such that the same engage into the contour or structure of the floor of another box during stacking (see, for example, Fig. 3), so that the boxes can be stacked on top of one another. Still, the lateral opening defined by the first side wall 16b allows the removal of bottles or bottle packs such as sixpacks from the inside of the box, even when the same is stacked.

In some embodiments of the invention, the areas of the side walls 14a, 14b and 16a facing the inside are designed in a light color so that the incidence of light through the openings 30a and 30b makes the bottles inside the box easily visible to a viewer looking in from the outside. In alternative embodiments, the areas are lined with product information or advertisements.

The embodiment shown in Fig. 1 further comprises, on at least one of the side walls (in the case shown here, the side wall 14b), a plurality of lands 32a to 32d running in a vertical direction and projecting from a side area towards the inside which prevent the bottles held inside the box by the mandrels from touching the side wall with their whole side area and to extensively contaminate the same. In the embodiment shown in Fig. 1, the lands 32a to 32d are each arranged such that the bottles abut on the outside wall with their outermost radius at the positions of the lands 32a to 32d. In this way, it can be avoided that large areas of the inside surfaces of the side walls are contaminated, since this is merely the case for the lands.

Fig. 2 shows the embodiment of the box 10 of Fig. 1 in a state filled with 3 sixpacks.

The sixpacks 40a, 40b and 40c each include six individual bottles which are not illustrated here for reasons of clarity.

Here, in addition to the mandrels which engage the six-packs from below, which are open at the bottom for this purpose, the six-packs are held by the lands 40a and 40b, which are arranged on the bottom 12 of the box 10 as illustrated in Fig. 1.

As becomes clear from the view of Fig. 3 showing the two boxes 10 and 10a in a stacked state, the products or bottles can also be removed from the lower box 10 in the stacked state. This, of course, also applies for the sixpacks 40a, 40b and 40c when the same are transported or presented in the boxes as an alternative to individual bottles. As becomes obvious from Figs. 2 and 3, the specific embodiment of a box shown in Fig. 1 has high flexibility with regard to the bottles to be transported since, on the one hand, sixpacks and, on the other

hand, individual bottles can be transported by the box. This results from the arrangement of the mandrels 22a and 22b as well as the lands 42a and 42b illustrated in Fig. 1.

It is obvious that in other embodiments of the box 10 the mandrel arrangement can be selected differently. For example, in some embodiments lands can be completely omitted and instead only mandrels can be used. In the embodiment shown in Fig. 1, both are possible, since every individual bottle inserted into one of the spaces between mandrels and/or lands is supported in four directions in each case either by a side wall of a land, by a mandrel or by one of the side walls 14a, 14b, 16a or 16b of the box, so that the same is held in a stable manner for transport.

As can be seen in Fig. 3, due to the stackability of the boxes and the option of lateral removal provided by the first side wall 16b, it is now possible to offer different products for sale in a column of stacked boxes. Here, the side wall 16b, together with the mandrels, prevents the bottles from tilting out of the box 10 during transport, which is why the side wall 16b is dimensioned so as to prevent bottles from tilting out of the box during transport. At the same time, it remains low enough for the bottles to be taken out of the box towards the front even if a further box 10a is on top of the box 10. For this purpose, according to some embodiments, the bottles can first be slightly lifted and then tilted towards the front. This is enabled in some of the embodiments by a specific implementation of the mandrels, as will be described in more detail below with reference to Fig. 12.

Fig. 3 shows clearly a further characteristic of some embodiments of the present invention, namely the specific design of grip openings 28a and 28b. The grip opening is bent and extends both horizontally and vertically. In other words, the grip opening 28a comprises a first opening area 50a extending parallel to the floor 12, and a second opening area 50b running substantially in a vertical direction 18. Here, the limitation between the vertical and the horizontal opening area in Fig. 3 is only meant exemplarily. Thus, the grip opening 28a also extends with significant extension in the vertical direction, so that the grip opening 28a can also be used in the vertical opening area by a person. In alternative embodiments of the invention, the grip opening 28a can, of course, also be formed differently than in the embodiment shown in Fig. 3. For example, the same can also have a square or rectangular cross-section, so that the box can be lifted both from the top by means of the horizontal opening area 50a and from the side by means of the vertical opening area 50b.

In the embodiment shown in Fig. 3, the vertical opening area is on the side allocated to the first side wall 16b and merges into the horizontal opening area 50a at the outer contour (i.e. at the contour pointing in the direction of the first side wall) with a large radius. This has the effect that, when lifting the box, the same can also be gripped in the radius, so that the box, when the vertical opening area is on the side allocated to the first side wall 16b, tilts backwards (in the direction of the side wall 16a) so that the individual bottles are additionally prevented from falling out by the tilting of the box when being carried.

In some embodiments of the invention it is illustrated, based on Fig. 4 which shows a perspective view from the bottom to the box of Fig. 1, and based on Fig. 11 which shows a bottom view of a further embodiment of the invention, how a special design of the floor 12 in the area 50 abutting on the first side wall 16b additionally increases security.

In accordance with the invention, the floor 12 is not formed across the whole area, but is formed by an arrangement of fins for saving weight and for easier cleaning. The same cover the area of the floor 12 such

that the bottoms of the individual bottles rest securely on the floor 12. In the area 50 of the front edge, i.e. in the area 50 adjacent to the first side wall 16b, the number or area density of the fins is increased compared to the rest of the area, so that the bottles located there cannot tilt to the outside by themselves, even if they are tilted by external influences from their resting position slightly in the direction of the first side wall 16b. This is avoided by placing the fins in the area 50 adjacent to the first side wall 16b so closely that the edge of a bottle cannot tilt between the space between two adjacent fins. In other words, in the area 50 adjacent to the first side wall 16b, the floor 20 comprises a supporting area for the bottles which is larger than the supporting area provided on average across the floor per area unit, in order to enable the bottles to be securely held.

As can further be seen from Fig. 4, the floor 12 comprises, at the area adjacent to the side walls 14a, 14b and 16a, an elevation of several fins, whose contour is implemented such that, when placing the same on another box, the inside of the side walls engages into the contour of the side walls of the further box in order to ensure stackability and a firm stance in the stacked state.

Further, the floor of the box, in its center, comprises a bar 52 extending from the side wall 16a to the first side wall 16b and whose lands have a larger extension in the vertical direction than the other lands of the floor. This bar 52 serves to additionally support the first side wall 16b of lower height in order to increase the stability of the box. The bar 52 is arranged in the center so that the bar extending further downwards than the rest of the floor does not obstruct removal of the bottles from the lower box in the stacked state.

Fig. 5 shows a further embodiment of the present invention of a box differing from the embodiments discussed based on the previous figures substantially in that other sizes of bottles can be transported with the embodiment shown in Fig. 5. While the embodiment shown in Fig. 1 is adapted to bottles having a content of 0.5 l, the embodiment shown in Fig. 5 of a box is adapted to bottles having a content of 0.33 l. Thus, the embodiment of Fig. 5 differs substantially in the arrangement of mandrels from the embodiment of Fig. 1 as well as in the thickness of the side walls 14a, 14b and 16b which had been changed to hold the bottles arranged inside the box with the same outer volume of the box. Thus, for example, the box shown in Fig. 5 comprises five mandrels 54a, 54b, 54c, 54d and 54e, which abut on the first side wall 16b to hold, all in all, six bottles of 0.33 l content in the first row. Further, the box of Fig. 5 comprises merely one continuous land 56 in the center of the box, so that alternatively four sixpacks can be transported with the box.

Further, the embodiment of Fig. 5, in contrary to the embodiments of Figs. 1 to 4, shows the box with a movable side wall area 23 folded upwards at the first side wall 16b. Since, otherwise, the design features of the box of Fig. 5 correspond to those of Fig. 1 and each have an identical functionality, a renewed discussion of the components corresponding to the box of Fig. 1 is omitted. Additionally, it should be mentioned that the box shown in Fig. 5, like the box shown in Fig. 1, comprises at least one opening 58 at the side wall 16a opposing the first side wall 16b extending through the side wall 16a so that the box can be fixed or hung up on a wall or shelf or the like by means of the opening.

For increasing the security of the mounting, the embodiments shown in Figs. 1 and 5 each comprise an optional additional second mounting opening 60.

The embodiment shown in Fig. 6 is also configured for transporting 24 bottles having a content of 0.33 l each, and largely corresponds to the embodiment shown in Fig. 5. However, in the embodiment of Fig. 5,

the side walls 14a, 14b and 16a or at least parts of the side walls 14a, 14b and 16a are arranged in a foldable manner by means of hinges with respect to the floor. Thereby, the same are foldable in such a manner that they can be folded in the direction of the floor and are substantially parallel to the floor in the folded-in state, as is illustrated in Fig. 7 for the side wall 16a, which is parallel to the surface of the floor 12 in the folded-in state. Fig. 8 shows all side walls 14a, 14b and 16a in the folded-in state, so that in the folded state the box can easily be transported back to the brewery or a bottler without taking up much space. This can significantly reduce the cost of transport.

Although, based on Figs. 6 to 8, the foldable side walls 14a, 14b and 16a are only shown for a box which is configured to transport 24 bottles at 0.33 l each, it is obvious that also the box shown in Fig. 1 for 0.5 l bottles can be provided with foldable side walls. Generally, it applies for all embodiments illustrated herein that the features described or shown based on the individual embodiments can be combined with one another in any manner in order to obtain alternative further embodiments of inventive boxes.

Fig. 9 illustrates the embodiment of Fig. 5 in the loaded state, where there are 24 bottles inside the box.

Also, as in Fig. 5, the movable side wall area 23 is in the folded-out position in order to additionally secure the bottles of the frontmost row or in order to attach product labeling for transport on the outside of the flexible part 23 which is not relevant for the presentation of the goods.

Fig. 10 shows the embodiment of Fig. 5 with an alternative form of loading, namely with four sixpacks 70a, 70b, 70c and 70d.

Finally, Fig. 11 shows a top view of the embodiment of Fig. 5 wherein it is obvious that the mandrel 54c has a different geometrical shape than the mandrels 54a, 54b and 54d or 54e in order to allow the insertion of sixpacks. In alternative embodiments, however, the center mandrel 54c can naturally have the same form as the other mandrels, such as, for example, mandrel 54a. Likewise, any other mandrels can have the shape of the mandrel 54c.

As can be seen in the top view of Fig. 11, also for the case of boxes for 24 beverage bottles, the floor 12 in the area 50 adjacent to the first side wall 16 is also designed with a larger supporting area than the average supporting area of the whole floor in order to avoid undesirable tilting out of the bottles from the box.

Fig. 12 shows an enlarged illustration of the mandrels 54a to 54c so that their special shape becomes visible which, in combination with the first side wall 16b, allows the bottles both to be held securely and also to be removed from the front. In order to achieve this, several embodiments of mandrels have an outer area whose height is not constant in the vertical direction 18. In the following, the shaded area 70, i.e. the area or the area elements limiting the mandrel laterally, i.e. in all directions orthogonally to the vertical direction 18, is to be understood as an outer limitation area of the mandrel 54a.

The outer limitation area 70 has a varying height, as has already been described above. Thereby, the mandrel is less high in a first side surface area 75 running parallel to the first side wall 16b and securing a bottle towards the back (in the direction 72 pointing away from the first side wall 16b) compared to a second side surface area 76 securing the bottle against tilting in a direction 74 parallel to the first side wall 16b.

In the mandrel 54a shown in Fig. 12, which has a substantially rhombus-shaped cross-section, the one tip of which points in the direction of the first side wall 16b, the function of preventing tilting to the back is fulfilled by a first limiting surface area 75, which terminates the mandrel substantially in the direction parallel to the first side wall 16b. A second limiting surface area 76 limiting the mandrel 54b in the direction of the first side wall 16b prevents the bottles from tilting parallel to the first side wall 16b.

The first side surface area 75 is lower than the second side surface area 76 in order to allow tilting the bottles, when tilting them out to the front, without having to lift the bottles so far up that they might hit the floor of a further box stacked on top of the box being considered.

However, the second limiting surface area 76 prevents tilting in the direction parallel to the first side wall 16b and can hence be higher in order to increase stability. Generally, both the mandrels 54a and 54b and the mandrel 54c effect maximum stability while simultaneously allowing tilting out to the front, in that the mandrels have a lower height in the direction parallel to the side wall than in the direction perpendicular to the side wall.

Further, the mandrels in Fig. 12 are provided with outer limiting partial areas which are curved to the inside in a concave manner between the tips of the substantially rhombus-shaped basic form, wherein the radius of the curve substantially corresponds to the cross-section of a bottle in order to be able to hold the bottle even more securely.

Although discussed above mainly in the context of beverage boxes, further embodiments of the present invention are, of course, also usable for other types of products. For example, beverage cans as well as any other cylindrical goods, such as hair spray, deodorant spray cans, etc., can be transported with the inventive boxes. Further, the boxes with a lateral opening are also suitable for completely different types of products which can also deviate from a cylindrical basic form. The boxes are universally usable for all possible products, since they allow the products to be also removed from the box laterally in the stacked state. This great advantage is not limited to the type of transported goods.

SZÁLLÍTÓ- ÉS BEMUTATÓLÁDA

Szabadalmi igénypontok

1. Láda (10)

aljjal (12); továbbá

legalább két pár, egymással szemben húzódo oldalfallal (14a, 14b, 16a, 16b), ahol az oldalfalak közül egy első (16b) az aljtól (12) függőleges irányban (18) felfelé legalább részben csupán egy kivételi magasságig (20) terjed, amely kisebb, mint a többi oldalfal (14a, 14b, 16a) közül egy vagy több magassága, hogy egy oldalsó nyílást határozzon meg, olyan mérettel, amely lehetővé teszi a lądában (10) lévő termékekhez az oldalsó nyíláson keresztül a hozzáférést és a kivételt,

ahol az első oldalfal (16b) rögzített, továbbá az első oldalfaltól (16b) különböző többi oldalfal (14a, 14b, 16a) az aljhoz (12) viszonyítva úgy van mozgathatóan elrendezve, hogy az alj (12) irányában lehajtott állapotba

hajtható le, melyben lényegében az aljjal (12) párhuzamosan húzódik, továbbá

ahol az aljnak (12) egy az első oldalfalat (16b) határoló tartományban (50) a szállítandó termékek számára tartófelülete van, amely nagyobb, mint átlagban az alj (12) fennmaradó területe,

ahol az alj (12) nincs a teljes területen kiképezve, hanem azt az alj (12) területét fedő bordák elrendezése képezi, továbbá

ahol a bordák száma, illetve területi sűrűsége az első oldalfalat (16b) határoló tartományban (50) a fennmaradó tartományhoz képest meg van növelve.

2. Az 1. igénypont szerinti láda (10), amelynél az első oldalfal (16b) egy vagy két oldalfal szakasszal rendelkezik, amelyek a határoló oldalfalak egyikétől kiindulva az oldalsó nyílás irányában húzódnak és olyan magasságúak, amely nagyobb, mint a kivételi magasság (20).

3. Az 1. vagy a 2. igénypont szerinti láda (10), rövid oldalfalak (14a, 14b) első párjával és hosszú oldalfalak (16a, 16b) második párjával, ahol az első oldalfal (16b) a hosszú oldalfalak (16a, 16b) egyike.

4. Az 1-3. igénypontok bármelyike szerinti láda (10), amely továbbá egy függőleges irányban (18) az első oldalfalon (16b) felfelé húzódó mozgatható oldalfal tartománnyal (23) rendelkezik, amely az első oldalfalhoz (16b) képest az alj irányában lehajtható.

5. Az 1-4. igénypontok bármelyike szerinti láda (10), amelynél az első oldalfalat (16b) határoló oldalfalaknak (14a, 14b) egy-egy hordnyílásuk (28a, 28b) van a láda (10) megemelésére, ahol egy hordnyílásnak (28a, 28b) egy-egy első, az aljjal párhuzamosan húzódó nyílástartománya, és egy második, az első oldalfal (16b) felé néző hordnyílás (28a, 28b) oldalon található, lényegében függőleges irányban húzódó nyílástartománya van, ahol a nyílástartományok (28a, 28b) az aljjal (12) ellentétes oldalon egy átmeneti tartományban görbülettel mennek át egymásba, amely a láda megfogását az ármeneti tartományban is lehetővé teszi.

6. Az 1-5. igénypontok bármelyike szerinti láda (10), amelynél az első oldalfalat (16b) határoló oldalfalaknak (14a, 14b) az első oldalfallal szomszédos végükön kisebb első magassága van, mint ellentétes végük második magassága, ahol az első oldalfallal (16b) szomszédos oldalfalak (14a, 14b) magassága az első magasságtól a második magasságig folytonosan nő.

7. Az 1-6. igénypontok bármelyike szerinti láda (10), amelynél a láda (10) alján (12) térkitöltő elemek (22a, 22b) vannak elrendezve, melyek a ládában (10) elhelyezett palackokat megtartón vannak kiképezve.

8. A 7. igénypont szerinti láda (10), amelynél a térkitöltő elemek legmagasabb pontjukon nem haladják meg az első oldalfal (16b) kivételi magasságát (20).

9. A 7. vagy a 8. igénypont szerinti láda (10), amelynél a térkitöltő elemeknek (22a, 22b) függőleges irányban (18) az aljtól (12) felfelé húzódó külső határoló felülete van, melynek magassága a térkitöltő elemek külső kerülete mentén változó.

10. A 9. igénypont szerinti láda (10), amelynél legalább egy térkitöltő elem (22a) egy a térkitöltő elemeket (22a) az első oldalfallal (16b) párhuzamos irányban határoló csekélyebb magasságú határoló felület tartománnyal (75) rendelkezik, mint egy a térkitöltő elemeket (22a) az első oldalfal (16b) irányában határoló második határoló felület tartomány (76).

11. A 7-10. igénypontok bármelyike szerinti láda (10), amelynél a térkitöltő elemek (22a) határoló felülete az

aljjal párhuzamosan egy lényegében rombusz keresztmetszettel rendelkezik, ahol a rombusz csúcsainak egyike az első oldalfal (16b) irányába néz.

12. A 11. igénypont szerinti láda (10), amelynél a térkitöltő elemek (22a) külső határoló felülete a rombusz alakú keresztmetszet csúcsai között homorúan befelé ívelt, ahol az ívelések sugara hozzávetőlegesen egy a 5 lédában tartandó palacktest sugarának felel meg.

13. Az 1-12. igénypontok bármelyike szerinti láda (10), amelynél az első oldalfal (16b) szétválaszthatóan van az aljjal (12) összekapcsolva.

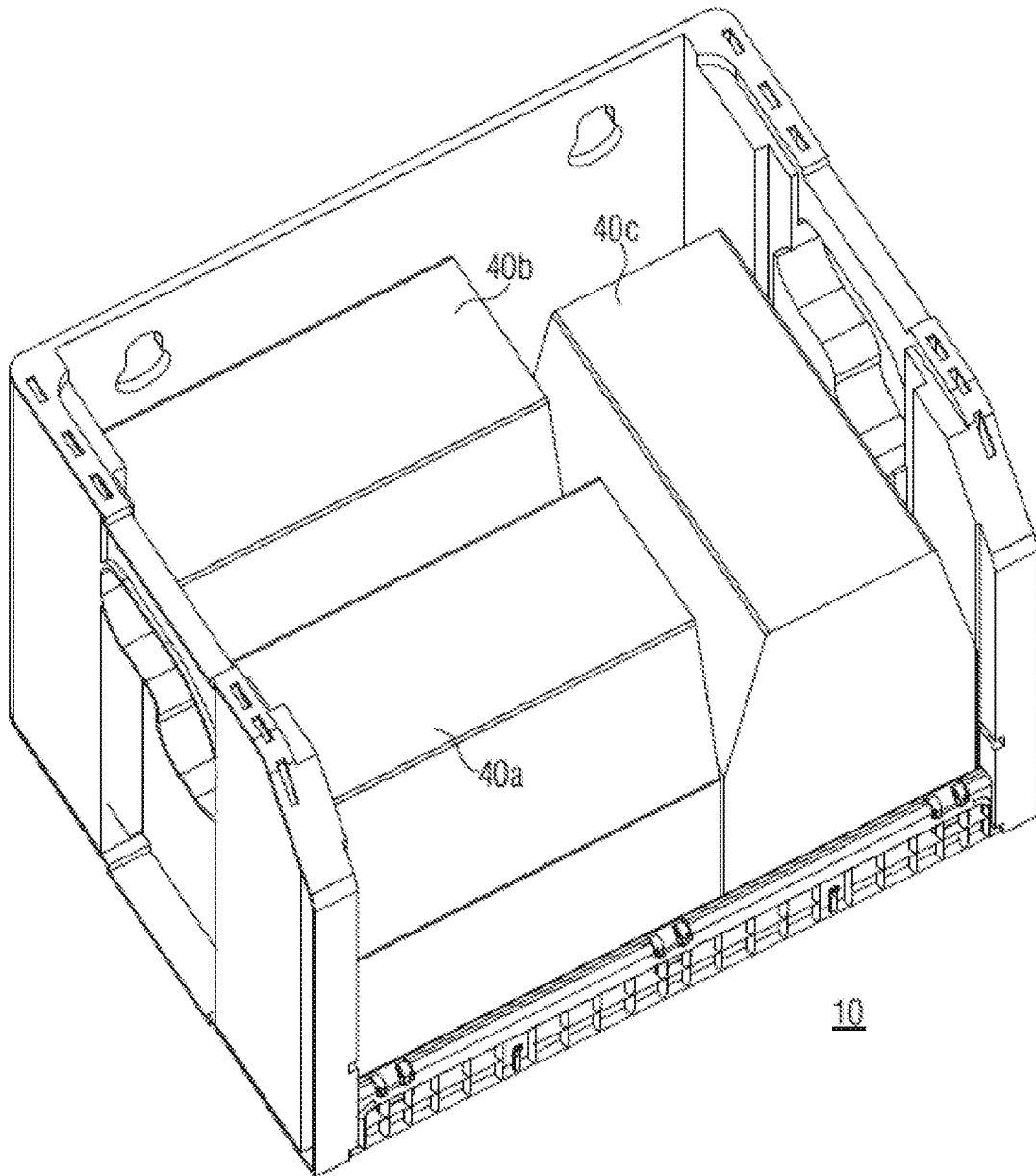

FIGURE 2

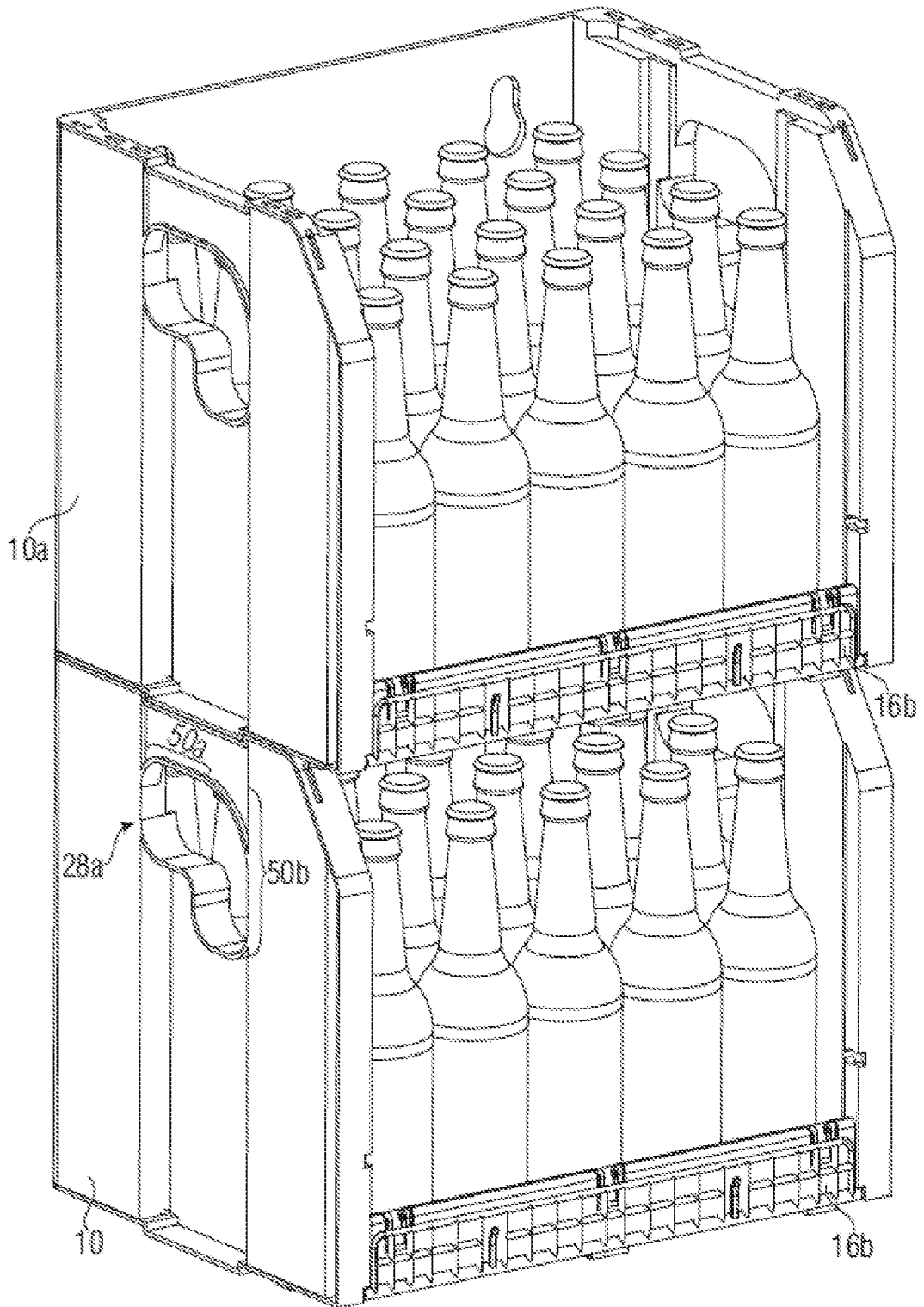

FIGURE 3

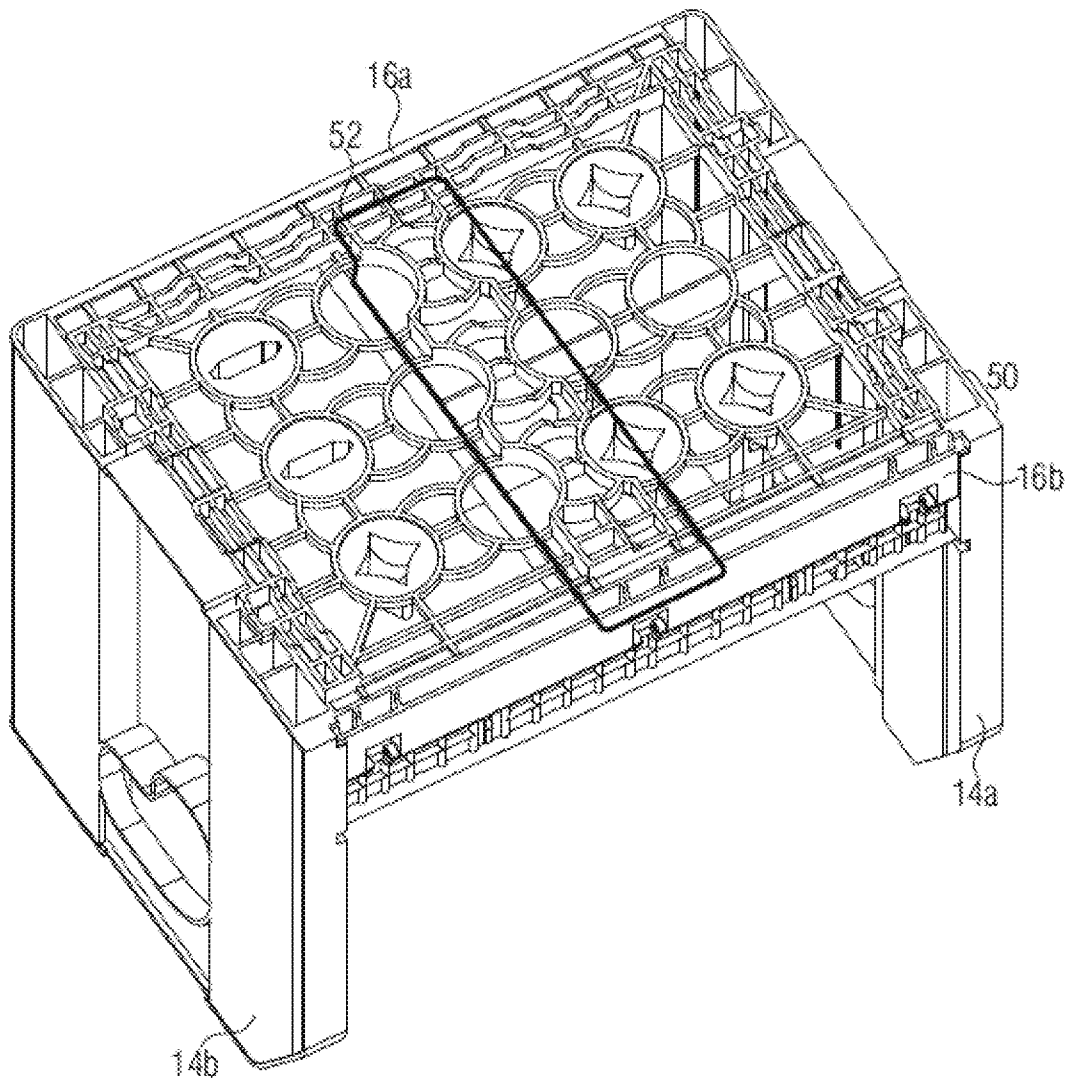

FIGURE 4

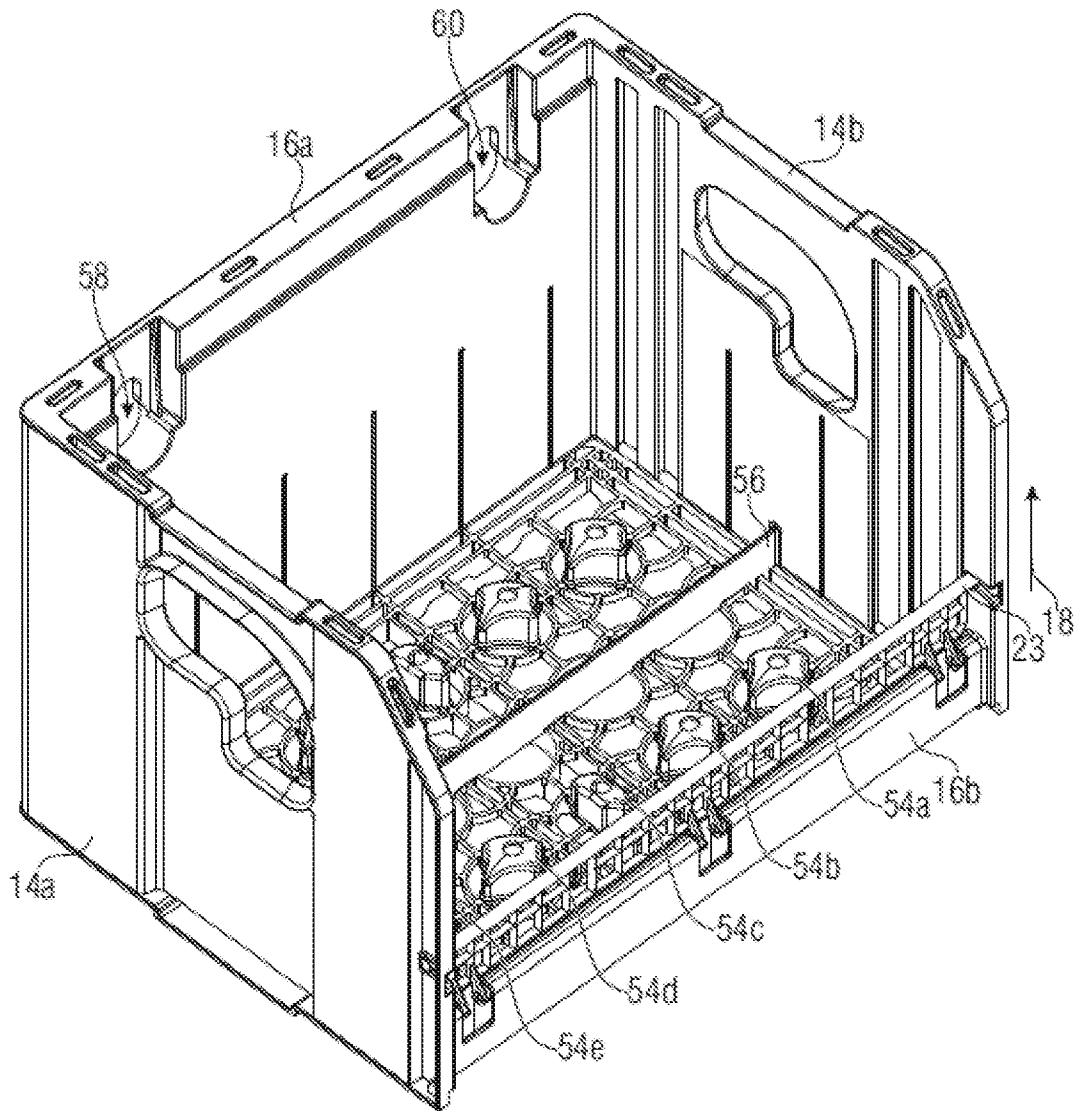

FIGURE 5

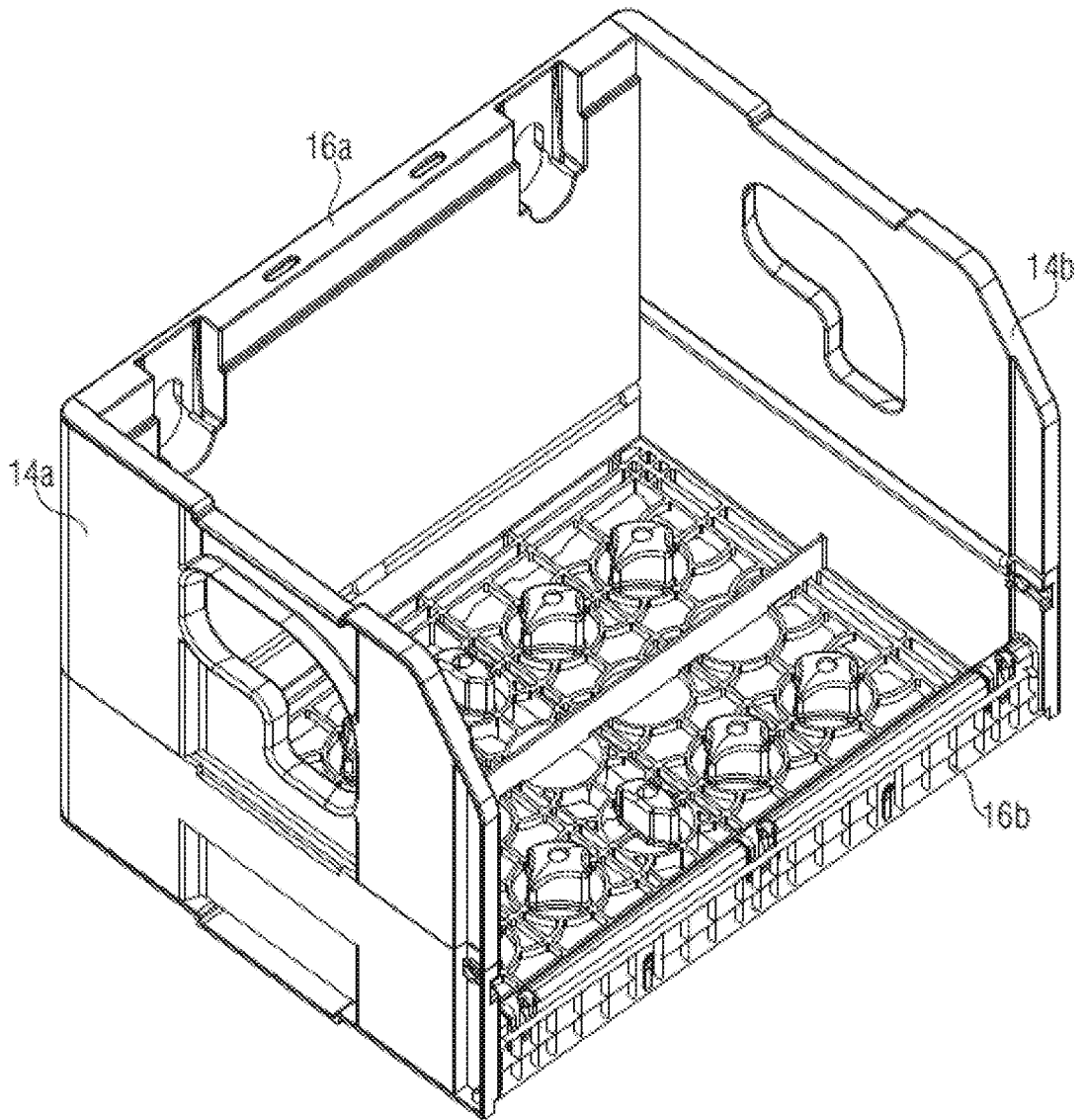

FIGURE 6

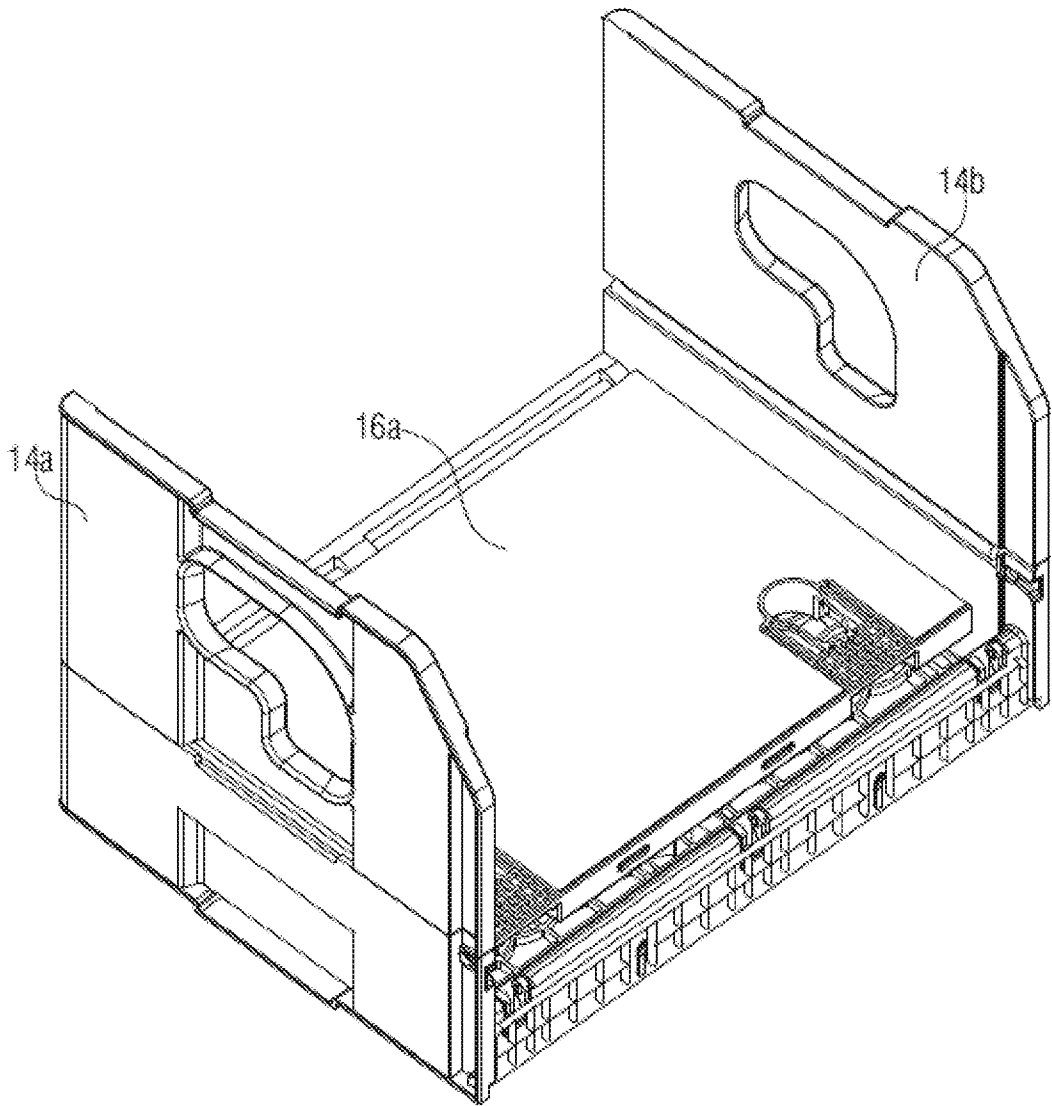

FIGURE 7

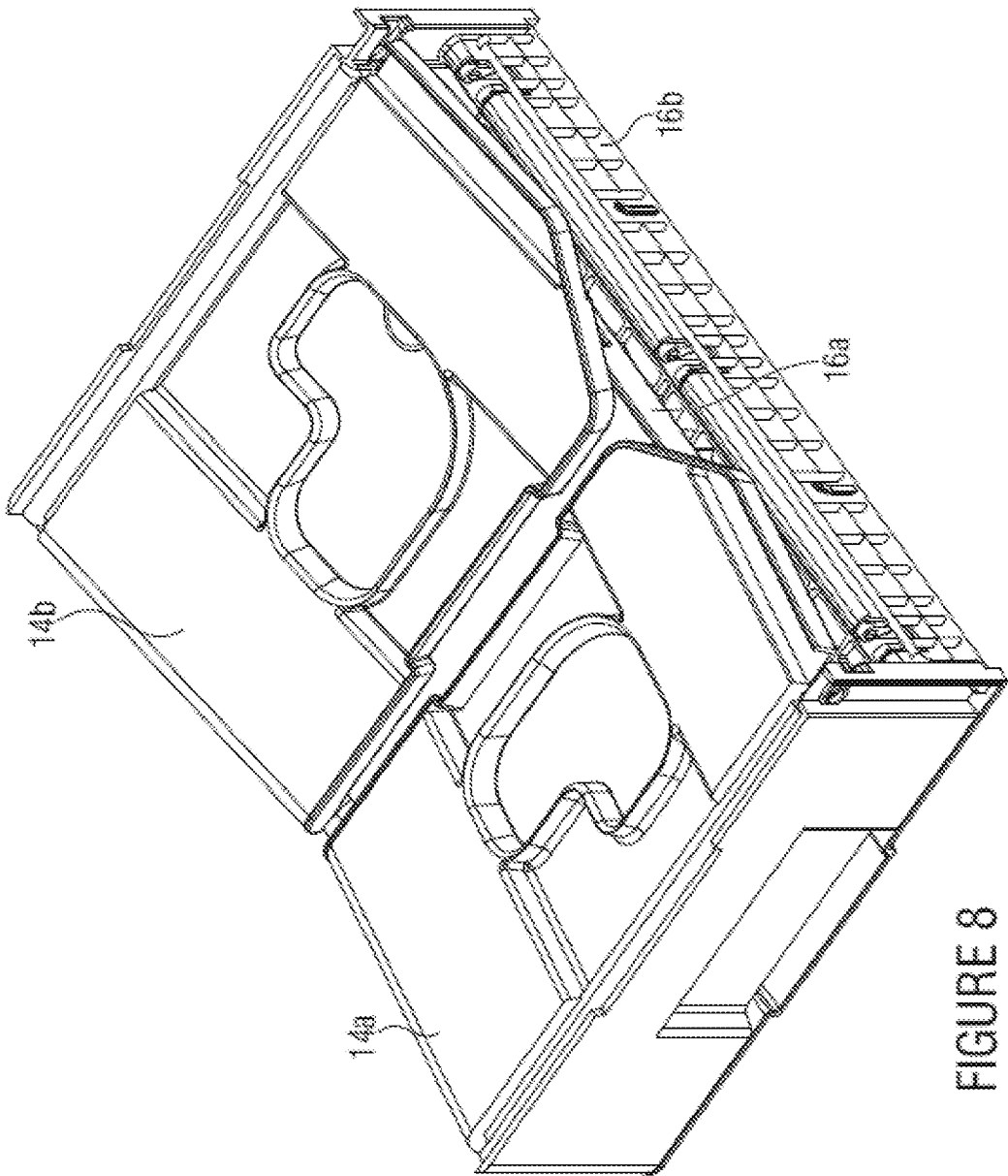

FIGURE 8

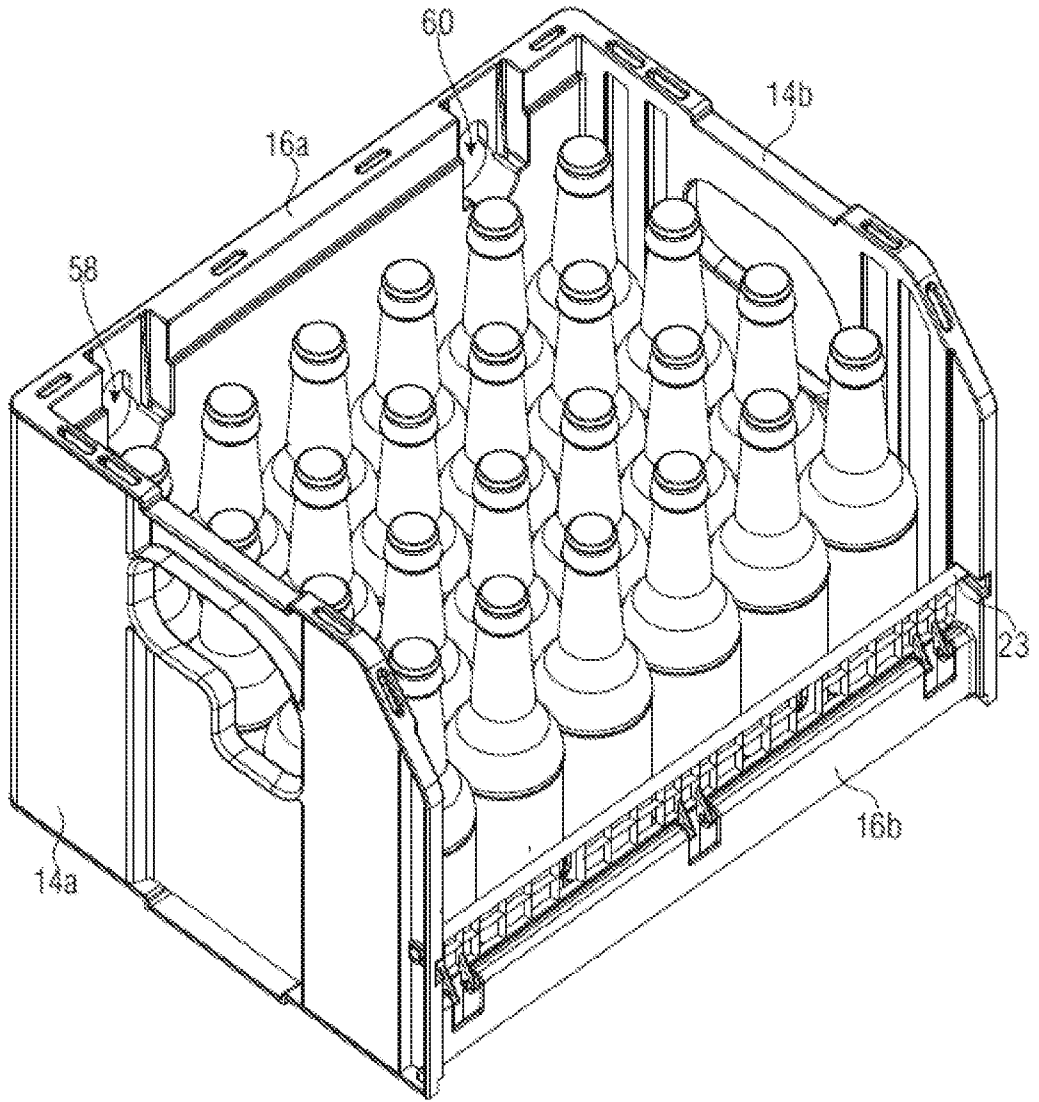

FIGURE 9

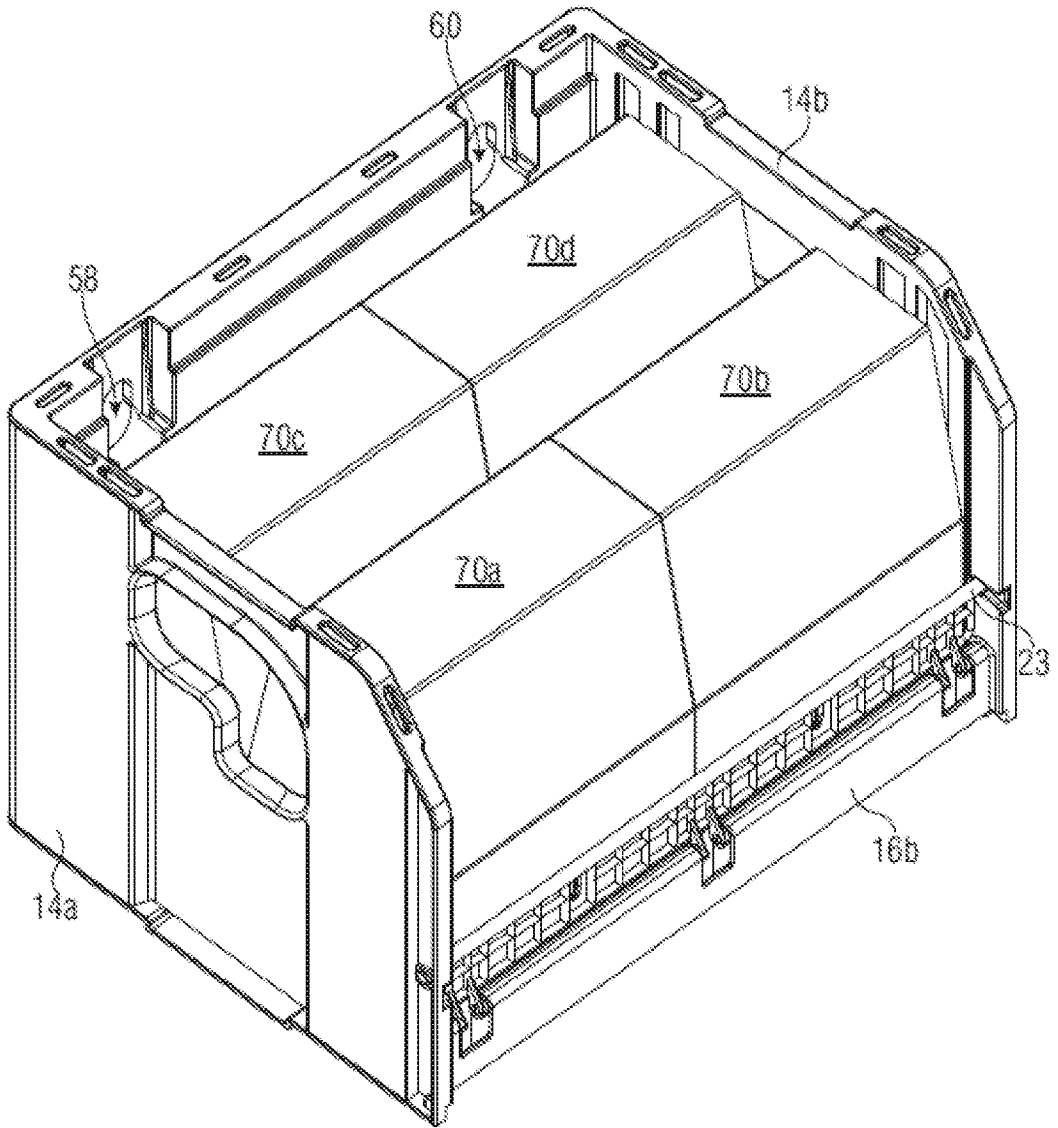

FIGURE 10

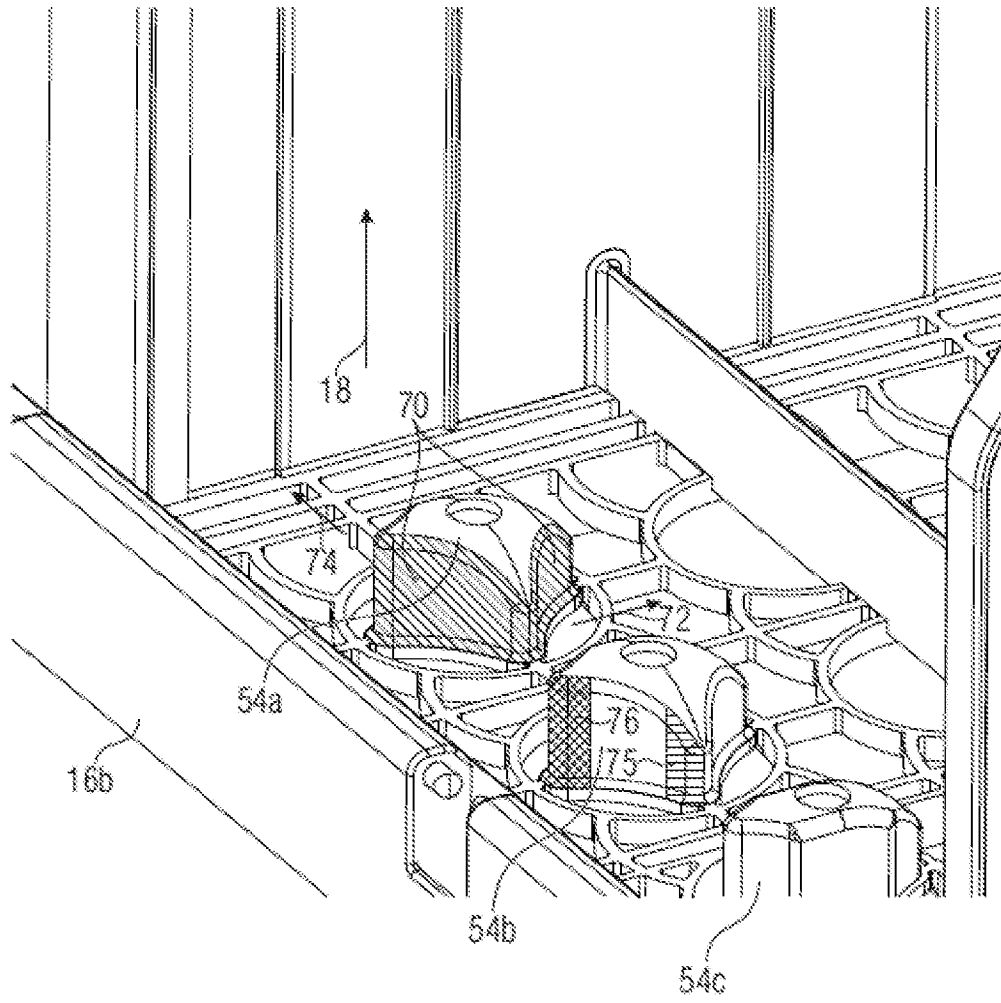

FIGURE 12