

(No Model.)

I. SMITH.
FIREPROOF SHUTTER.

No. 522,861.

Patented July 10, 1894.

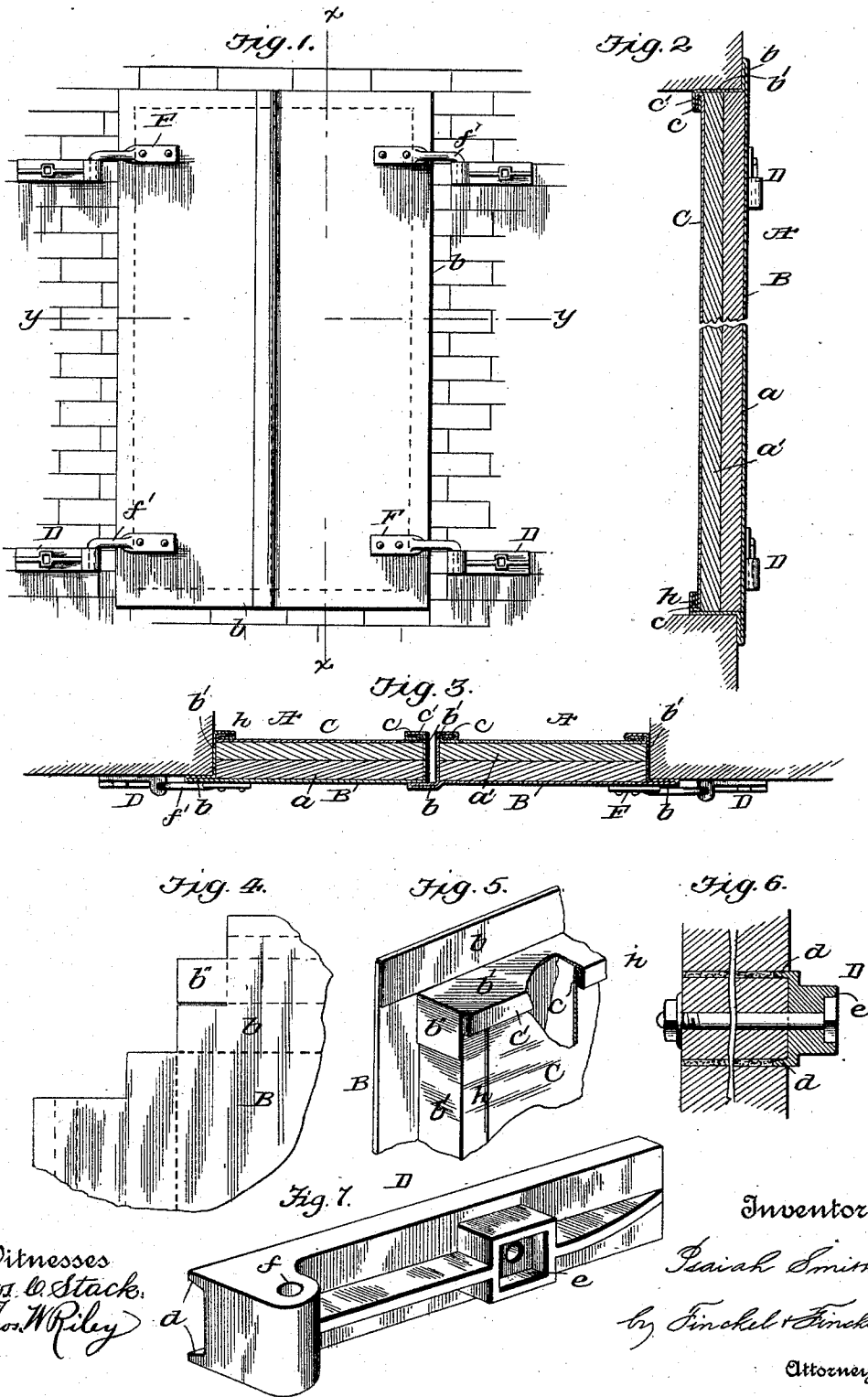

Witnesses
for I. Smith,
Thos. W. Riley

Inventor
I. Smith,
by Finchel & Finchel,
Attorneys

UNITED STATES PATENT OFFICE.

ISAIAH SMITH, OF COLUMBUS, OHIO.

FIREPROOF SHUTTER.

SPECIFICATION forming part of Letters Patent No. 522,861, dated July 10, 1894.

Application filed February 14, 1894. Serial No. 500,115. (No model.)

To all whom it may concern:

Be it known that I, ISAIAH SMITH, a citizen of the United States, residing at Columbus, in the county of Franklin and State of Ohio, have invented certain new and useful Improvements in Fireproof Shutters; and I do hereby declare the following to be a full, clear, and exact description of the invention, such as will enable others skilled in the art to which it appertains to make and use the same.

It is well known that fires often pass from one building to others through exposed windows and doors, the wood work on such windows or doors igniting thus affording the means for conveying the flames to the interior of the building. It is therefore plain that if shutters which shall not expose any readily combustible material and shall prevent access of the flames to the wood work of the window or doors can be provided the building will be reasonably safe.

Shutters composed wholly of iron are too heavy and expensive and are such good conductors of heat that they afford little more protection than the ordinary glass windows. Moreover they are liable to warp and form openings through which the flames may pass, and those composed of wood or other material and provided with the fire-proof coverings heretofore constructed are also liable to the access of water and the consequent expansion often distorts and impairs the covering so as to render the shutter worthless.

The object of my invention is to provide a shutter which shall be simple, cheap, and furnish efficient barriers to the access of fire. In carrying out my invention I make use of the fact that the exclusion of air from combustible material will give immunity from burning, and my invention therefore consists of a shutter formed of wood or other light material completely inclosed in a covering of sheet metal.

In the accompanying drawings, Figure 1 represents a front view of a window fitted with my shutters. Fig. 2 is a vertical sectional view on line $x-x$ of Fig. 1. Fig. 3 is a horizontal sectional view on the line $y-y$ of Fig. 1. Figs. 4 and 5 are details showing the method of constructing the fire proof covering for the

shutters; and Figs. 6 and 7 illustrate one of the members of a shutter hinge.

In constructing my shutter I take two or more well seasoned boards $a a'$ of the proper form and size which are secured together to prevent warping. These constitute the body of the shutter, and on the outside of this I fit a covering of sheet metal which is cut, bent, and folded to form the flanges b co-incident with the plane of the outer face of the shutter, flanges b' which cover the edges of the shutter, and the flap b'' to protect the corners. The inner edges of the flange b' are bent and folded to form a lap joint h on the edges c of the sheet of metal C with which I cover the inner side of the body portion A of the shutter.

An important detail of my improvements consists in the construction of the covering at the corner of the shutter. This construction is shown in detail in Figs. 4 and 5. Fig. 4 represents the way in which the corner is cut and Fig. 5 represents its appearance when folded. The downwardly turned portions c and c' cover the joints and prevent the ingress of water and consequent rusting or expansion by steam when water is thrown by firemen onto the building.

Where the window is small a single shutter will suffice, and the flanges b should be provided on each edge. When the shutters are in pairs the flanges b should be made on all four edges of one and on three edges of the other as shown in Figs. 1, 2, and 3 so that the space between the meeting edges will be closed. As the flanges b fit against the bricks of the wall access of the flames to the wood work of the window frame is prevented.

Additional resistance to fire may be provided by interposing a layer of asbestos between the wooden core A and the covering B or C, or both.

Another feature of my improvements consists in a hinge especially adapted for use in connection with my shutter. This hinge is shown in Figs. 6 and 7. It consists of a casting or plate D provided with flanges d which project into the mortar joint of the bricks in the wall. A bolt is passed through a suitable opening e in the plate and through the brick and secured by a nut and washer, as shown

on the inner side of the wall. The hole *f* in an ear on the plate or casting receives the pintle *f'* on the other plate *F* or leaf on the shutter. When the shutters are put up they are

5 coated with good paint to prevent rusting.

It will be observed that in my shutter no inflammable part is exposed; that all openings for the passage of flames to the window frame are closed; that it cannot warp and

10 thus make openings for the passage of the fire; and that they are good non-conductors of heat.

My shutters will be found especially valuable for large ware houses and stores situated on narrow alleys or streets and in close proximity to other perishable buildings.

15 What I claim, and desire to secure by Letters Patent, is—

1. A wooden shutter having a covering consisting of two sheets of sheet metal the outer

20 of which is cut and bent to form flanges *b* coincident with the face of the shutter, flanges

b' to cover the edges of the shutter, and the downwardly turned portions *b''* at the corners to cover exposed joints, and the inner sheet of which is connected by lap joints *cc'* 25 with the flanges *b'*, substantially as shown and described.

2. A hinge for fire proof shutters having a leaf formed with horizontal flanges *dd* to enter the mortar space between the bricks and 30 with the socket *f* to receive the pintle of the supplementary part of the hinge and with a hole for the passage of a bolt through said leaf, combined with a bolt and means for securing the same in the wall, substantially as 35 shown and described.

In testimony whereof I affix my signature in presence of two witnesses.

ISAAH SMITH.

Witnesses:

GEO. M. FINCKEL,
CHARLES A. FIELD.