



(22) Date de dépôt/Filing Date: 2000/04/26

(41) Mise à la disp. pub./Open to Public Insp.: 2001/10/26

(51) Cl.Int.⁷/Int.Cl.⁷ B65G 53/42, B08B 5/04

(71) Demandeur/Applicant:
BRANDT INDUSTRIES, LTD., CA

(72) Inventeur/Inventor:
CLOSE, JON, CA

(74) Agent: MCFADDEN, FINCHAM

(54) Titre : DISPOSITIF A DEPRESSION ET METHODE DE MISE SOUS VIDE DES GRAINS

(54) Title: GRAIN VACUUM AND METHOD FOR VACUUMING GRAIN

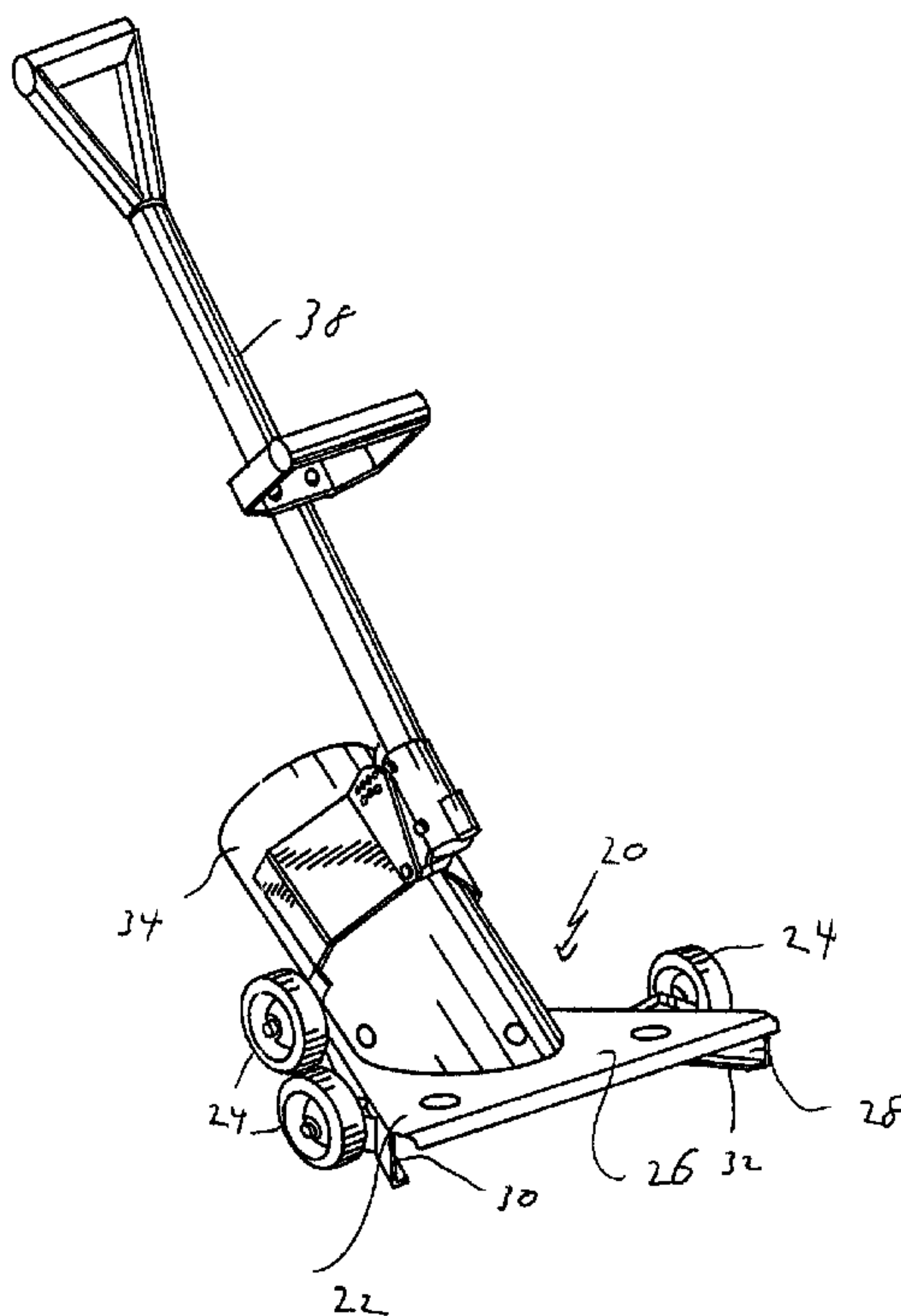

(57) **Abrégé/Abstract:**

A grain vacuum includes a vacuum head supported by wheels for rolling on a substrate. The vacuum head includes a collection chamber having an open scooplike front and an open bottom, for collecting grain and channeling the grain into a vacuum duct. The vacuum head may include a flow control, for controlling air flow through the vacuum, to permit the vacuum to efficiently collect various densities of grain. A method for collecting grain off a substrate by vacuum includes the step of introducing a supplementary air stream into the vacuum head, to permit the vacuuming up of relatively less dense grain. The supplementary airflow may be choked off to pick up grain having a higher density.

ABSTRACT

A grain vacuum includes a vacuum head supported by wheels for rolling on a substrate. The vacuum head includes a collection chamber having an open scooplike front and an open bottom, for collecting grain and channeling the grain into a vacuum duct. The vacuum head may include a flow control, for controlling airflow through the vacuum, to permit the vacuum to efficiently collect various densities of grain. A method for collecting grain off a substrate by vacuum includes the step of introducing a supplementary air stream into the vacuum head, to permit the vacuuming up of relatively less dense grain. The supplementary airflow may be choked off to pick up grain having a higher density.

GRAIN VACUUM AND METHOD FOR VACUUMING GRAIN

Field of the Invention

10 This invention relates to bulk handling of grains, and in particular to an apparatus for vacuuming loose grain from within a bin or otherwise off of surface, for transfer into a storage container or the like. Grain vacuum devices of this type are intended for hand manipulation by an operator.

Background of the Invention

20 Grain vacuums are used in grain handling to suction relatively small volumes of grain by hand-manipulating a vacuum device. Typical uses include clean-out of storage bins and the like. These vacuums consist generally of a vacuum head, which is intended to be manipulated by an operator, connected to a vacuum source and a storage container or the like. Figure 1 illustrates the head portion of a typical prior art grain vacuum. In general, these devices consist of a flared nozzle connected to a vacuum source via a flexible duct, with a handle mounted to the head for manipulation by the operator. A pair of wheels permits the head to roll on a surface. Typically, the flared nozzle has a rectangular opening, which feeds into the generally round duct. The head is tilted rearwardly during use, to permit the operator to scoop grain into the nozzle. Prior art devices are characterized by an opening towards the front of the vacuum head, which serves as both a scoop and as the sole opening into the interior of the vacuum head.

30 Grain vacuums may be used for bin cleanup applications, in which case a high vacuum force is required. For this purpose, it is desirable for the vacuum head to be capable of being easily rolled across the bin floor and to readily scoop up and vacuum loose grain. However, a grain vacuum may also be used to convey grain of various types to a bin or other reposition for this application, it is desirable to control the air flow in response to different grain densities.

Prior art devices suffer in general from several drawbacks. The typical nozzle

10 configuration is relatively inefficient, since individual grain particles are confronted with the vacuum-generated airstream for the brief time it takes for the head to be passed over a particular spot. As well, as the head is tilted rearwardly, a large part of the nozzle is displaced away from the ground. These factors result either in a requirement for a more powerful vacuum source, or alternatively more work on the part of the operator who must then pass the vacuum over the same spot several times in order to effect a complete grain pickup. Prior art devices are also not provided with any means for controlling the force of the suction at the vacuum head. Thus, if the operator is using the vacuum to pick up lighter weight grain, the vacuum force may be too strong. This can result in difficulty in separating the grain from the air stream at the collection end of the vacuum. It is thus desirable to provide a means for controlling air flow within a grain vacuum head, in a manner that is easy to operate by the operator and is directly associated with the vacuum head.

20 Prior art grain vacuum arrangements typically achieve their "scooping" effect by tilting the head rearwardly, whereby one side of the nozzle forms a scooping surface for either contact with the ground surface, or riding closely above the surface. There are several drawbacks associated with this arrangement. If the underlying surface is bumpy, the nozzle can jam against the bumps. If the operator attempts to avoid irregularities by angling the nozzle upwardly, a gap is formed between the nozzle and the ground and thus not all the grain may be vacuumed and scooped up. This arrangement also requires concentration by the operator to maintain an appropriate angled position which permits the scooping surface to ride above the ground to avoid irregularities, but not by too much. It is thus desirable to provide a grain head which may be simply pushed along the ground surface, without requiring the operator to maintain a particular angle or range of angles of the device. This also can minimize back strain on the operator, and provide for greater ease of use.

Summary of the Invention

30 An object of the present invention is to provide a grain vacuum device, having a vacuum head which is easy to operate and effective in comparison with the prior art. In particular, it is an object to permit effective suction pickup of grain. It is a further

object to provide a grain vacuum having readily adjustable airflow to easily permit use of the device with different types of grain, without requiring control of the power level of the vacuum power source.

10 A more efficient vacuuming operation is permitted, by providing a vacuum head in which the opening into the collection chamber is both at the front, to achieve a scooping action, and on the bottom, to permit an effective and efficient pickup operation by the vacuum airstream.

The invention comprises in one aspect a head portion of a grain vacuum. The head has a hollow interior comprising a collection chamber. The head includes a wheeled base for rolling on a substrate; attachment means to mount a vacuum duct to said base; and an aperture communicating with said attachment means and the collection chamber of the vacuum head. The base has a partially enclosed region open both to the front and bottom and defined by lateral and rear sidewalls and a top. The front and bottom openings both communicate with the collection chamber. 20 The front opening comprises a grain scoop. The sidewalls each have a lower edge which generally parallels the substrate and rides slightly above the substrate, with the sidewalls forming an open-fronted scoop for capturing grain resting on said substrate within said partially enclosed region for transport by vacuum through said aperture and into said vacuum duct.

Preferably, the sidewalls flare outwardly and forwardly to concentrate grain in a central region of said head as said head is wheeled forwardly. The lateral sidewalls may each have a lower inwardly-turned edge to provide structural rigidity and minimize exposed edges. 30

Conveniently, the top of said base comprises a generally flat plate-like member having a configuration of a truncated triangle, with tapered sides, a narrow trailing edge and a broad leading edge.

In a further aspect, a grain vacuum head includes a vacuum flow control means

associated with a grain vacuum head. The flow control means comprises an opening within the vacuum head, with the opening being selectively blocked by a moveable damper. Preferably, the moveable damper comprises a plate slidable relative to said opening, for selectively blocking said opening, whereby said opening may be either fully blocked, fully opened or partially blocked at a selected intermediate position.

In a further aspect, the invention comprises a grain vacuum system which includes a head having both a damper of the type characterized above, and a base portion as characterized above. The damper may alternatively communicate directly with the duct portion of the vacuum system.

In a still further aspect, the invention comprises a method for controlling the velocity of grain or seed through a grain vacuum, said grain or seed having a bulk density, comprising the steps of:

providing a grain vacuum comprising a vacuum head, a vacuum duct communicating with a vacuum source and said head, and an opening into said head selectively blocked by a moveable covering means of the type characterized above;

vacuuming grain into said duct via said vacuum head;

selectively introducing a supplementary air stream into said head and said vacuum duct via said opening, said air stream selected to correspond with the bulk density of said grain whereby a relatively high supplementary air flow is introduced in to said vacuum duct when said apparatus is used to vacuum up a relatively less dense grain, in comparison with a relatively low supplementary air flow introduced when said device is used for vacuuming up a grain type having relatively higher density in bulk; and

separating substantially all of said grain from said air flow within a collection container.

The grain may comprise grass seed, and said opening is adjusted to permit substantially maximal supplementary air stream to enter therethrough.

Having thus generally characterized the invention, the invention will now be described by way of a detailed description of a preferred embodiment, accompanied by drawings.

Brief Description of the Drawings

Figure 1 is a perspective view of a prior art of a portion of a grain vacuum, showing the vacuum head;

Figure 2 is a perspective view, generally from the front, of a grain vacuum according to the present invention;

Figure 3 is a side elevational view of the invention;

Figure 4 is a rear elevational view of the invention;

Figure 5 is a front elevational view of the present invention;

Figure 6 is a perspective view of the suction control portion of the grain vacuum head;

Figure 7 is a perspective, exploded, view of the portion shown in Figure 6; and

Figure 8 is a perspective view, showing the underside of a grain vacuum head according to the present invention.

Detailed Description of the Preferred Embodiment

Figure 1 illustrates a prior art grain vacuum head 10, comprising a flared nozzle 12 which communicates with a vacuum duct 14. The vacuum duct 14 in turn

communicates with a vacuum source and grain storage container, neither of which are shown but are well known in the art. At the container region, grain is separated from the airflow, with air and accompanying dust being discharged, and the vacuumed grain settling within the container. The flared nozzle 12 of the prior art arrangement, terminates in an essentially rectangular opening 16, which in operation is tilted rearwardly, whereby one side of the nozzle forms an angled lower pickup plate 17. A pair of support wheels 18 is mounted to the lower plate, to permit an operator to roll the head over a substrate, to essentially shovel grain into the nozzle. In use, since the head is tilted rearwardly, airflow through the nozzle is directed solely from the front end of the device. Thus, grain may easily be left behind after a first pass over the substrate, since any grain not directly shovelled into the nozzle on to the lower plate 17, will probably not be vacuumed up once the head has passed over such grain.

Turning to the present invention, illustrated at Figures 2 through 8, the grain nozzle head 20 forms a grain collection chamber. The head 20 consists generally of a generally horizontal base 22, which is supported on a substrate by a plurality of wheels 24 mounted to the base. The base consists of a generally flat plate 26 in the shape of a truncated triangle, the sides 28 of which flare outwardly towards the front end of the device. Sidewalls 30 depend downwardly along each of the angled sides of the base. Each sidewall terminates in an inwardly-angled lower end 32, to form scooping members for channelling grain towards the axis of the head. The opposed, diverging sidewalls define an open front end of the base 22 whereby grain may be scooped into the front end and pushed inwardly by the sidewalls 30 as the head is rolled forwardly on a substrate (the substrate is not shown, but is understood to consist of a generally level floor of a grain storage area). The base plate 26 angles slightly downwardly towards the rear of the head, with the sidewalls 30 having a corresponding truncated triangular profile whereby the lower edges of the sidewalls remain generally parallel to the substrate. The sidewalls are positioned to skim the substrate slightly above its surface, in order to generally avoid contact with irregularities in the substrate while still being able to scoop most grain resting on the substrate. The downward angling of the base plate, permits a generally open and

high front end for directing entry of grain into a region directly under the base. A vacuum nozzle communicates with the base plate towards the rear end thereof at a position where the base plate is closer to the ground, thereby permitting a more powerful vacuum force to be directed against grain resting on the substrate. A rear wall 35 depends from the rear edge of the base plate 26 to close off the region under the base plate 26.

A rigid vacuum tube 34 is mounted to the base plate 26, at a backwardly-sweeping angle. The vacuum tube meets the base plate at an oval opening 36 within the plate. The rigid vacuum tube communicates with a vacuum duct, not shown, which in turn communicates with a conventional vacuum source and grain container (not shown). A conventional rearwardly sweeping handle 38 is mounted to the vacuum tube adjacent the base region.

In operation, the vacuum 20 is pushed forwardly, with the weight of the vacuum on the substrate being borne by the wheels 24. An arrangement of wheels or rollers is provided to permit the head to be rolled across the substrate without being tilted. Thus, the wheels fully support the vacuum head on the substrate, without any operator assistance. As the vacuum is propelled forwardly, grain is scooped into the open front end of the base, and directed towards the nozzle opening by the converging flanges 30 in cooperation with the flow of air through the vacuum head 10.

Airflow through the vacuum device is controlled by means of a suction control means associated with the nozzle tube. The suction control means 40, illustrated more particularly at Figures 6 and 7, is mounted to the nozzle tube, at a position readily accessible to the operator. The suction control means consists of a housing 42, the open bottom of which communicates with the interior of the collection chamber within the interior of the head 20. The top 44 of the housing features a slot 46 communicating with the housing interior. The slot may be selectively blocked by means of an adjustable sliding slot cover 48, which is retained by means of retainers 50 mounted to the top of the housing. The slot cover 48 may be positioned to fully

cover the slot, thereby preventing any air entering through the slot, and thus maintaining full suction force through the vacuum nozzle. The suction force may be reduced by an amount selected by the operator, by fully or partly opening the slot covering, by sliding same along the retainer. A numerical scale 52 is printed on the housing cover to assist the operator. In the fully or partly opened position, outside
10 air is introduced to the vacuum tube, thereby reducing suction force through the vacuum nozzle. This adjustable flow control aides in the grain separation process by reducing the air stream volume and velocity such that the desired lighter particles are more likely to separate from the air stream and deposit it into a collector, while the air and dust is expelled into the atmosphere.

The carrying capacity of the air stream passing through the vacuum ducts is directly related to the velocity of the air stream. For light, bulky grains such as sunflowers, oats and grass seeds, the vacuum is too great in the full vacuum mode of operation to effectively separate grain from the air stream within the collection chamber. By
20 partly or fully opening the intake vent, the air velocity is decreased and air volume travelling through the vacuum hoses is correspondingly decreased, thus allowing separation of the desired grain particles from the air stream. An appropriate nozzle opening is selected by reference to density and other characteristics of the particular grain, with very light products such as grass seed requiring a greater vent opening. It is important to insure that the air inlet at the vacuum nozzle is not choked off excessively; a suitable opening must be selected to correspond with the grain density.

The air inlet vent is typically used if the operator experiences product discharge from
30 the vacuum exhaust. If this occurs, the vent must be then fully opened to permit the vacuum to clean itself out before resuming normal operation.

The air inlet vent, with flow control means, may also be used in conjunction with a conventional prior art-type vacuum head, to permit same to be effectively used as a multi-grain conveyor.

THE EMBODIMENTS OF THE INVENTION IN WHICH AN EXCLUSIVE PROPERTY OR PRIVILEGE IS CLAIMED ARE DEFINED AS FOLLOWS:

1. A grain vacuum head comprising a wheeled base for rolling on a substrate; a collection chamber within the interior of said head; a plurality of rollers for fully supporting said head on said substrate; attachment means to mount a vacuum duct to said base; an aperture communicating with said attachment means; said collection chamber having an open scooplike front and an open bottom for collecting grain.
2. A grain vacuum head as defined in claim 1, wherein said open front and bottom of said collection chamber comprises side and rear sidewalls depending from said base.
3. A grain vacuum as defined in claim 2, wherein said sidewalls flare outwardly and forwardly to concentrate said grain in a central region of said head as said head is wheeled forwardly.
4. A grain vacuum head as defined in claim 2, wherein said lateral sidewalls each have a lower inwardly-turned edge, said sidewalls defining with said top a pair of opposed channels for capturing grain therebetween.
5. A grain vacuum head as defined in claim 2, wherein the top of said base comprises a generally flat plate member having a configuration of a truncated triangle, the broad base side of which forms the leading edge of said base.
6. A grain vacuum head as defined in claim 1, wherein there are provided four wheels for supporting said device on said substrate.
7. A grain vacuum head as defined in claim 1, further comprising a vacuum flow control means associated with said base, said flow control means comprising an opening within said base or said vacuum tube, said opening being

selectively blocked by a moveable damper.

8. A vacuum head as defined in claim 7, wherein said moveable damper comprises a plate slidable relative to said opening, for selectively blocking said opening, whereby said opening may be either fully blocked, fully opened or at a selected intermediate position.
9. A grain vacuum, comprising a vacuum head having a vacuum nozzle opening; a vacuum duct in communication with said head; and a vacuum flow control means associated with said head or said duct permitting operator control of a supplemental air flow through said vacuum duct, said flow control means comprising an opening communicating with said head or said duct, and a damper for selectively blocking said opening.
10. A grain vacuum as defined in claim 9, wherein said damper comprises a plate slidably mounted to said housing or said duct, for selective covering of said opening.
11. A grain vacuum as defined in claim 8, wherein said opening is provided within a housing mounted to and communicating with said head or said duct.
12. A method for controlling the velocity of grain or seed through a grain vacuum, said grain or seed having a bulk density, comprising the steps of:

providing a grain vacuum comprising a vacuum head, a vacuum duct communicating with a vacuum source and said head, and an opening into said head selectively blocked by a moveable covering means;

vacuuming grain into said duct via said vacuum head;

selectively introducing a supplementary air stream into said head and said vacuum duct via said opening, said air stream selected to correspond with the

-11-

bulk density of said grain whereby a relatively high supplementary air flow is introduced in to said vacuum duct when said apparatus is used to vacuum up a relatively less dense grain, in comparison with a relatively low supplementary air flow introduced when said device is used for vacuuming up a grain type having relatively higher density in bulk;

separating substantially all of said grain from said air flow within a collection container.

13. A method as defined in claim 12, wherein said grain comprises grass seed and said opening is adjusted to permit substantially maximal supplementary air stream to enter therethrough.

Fig. 1
(Prior Art)

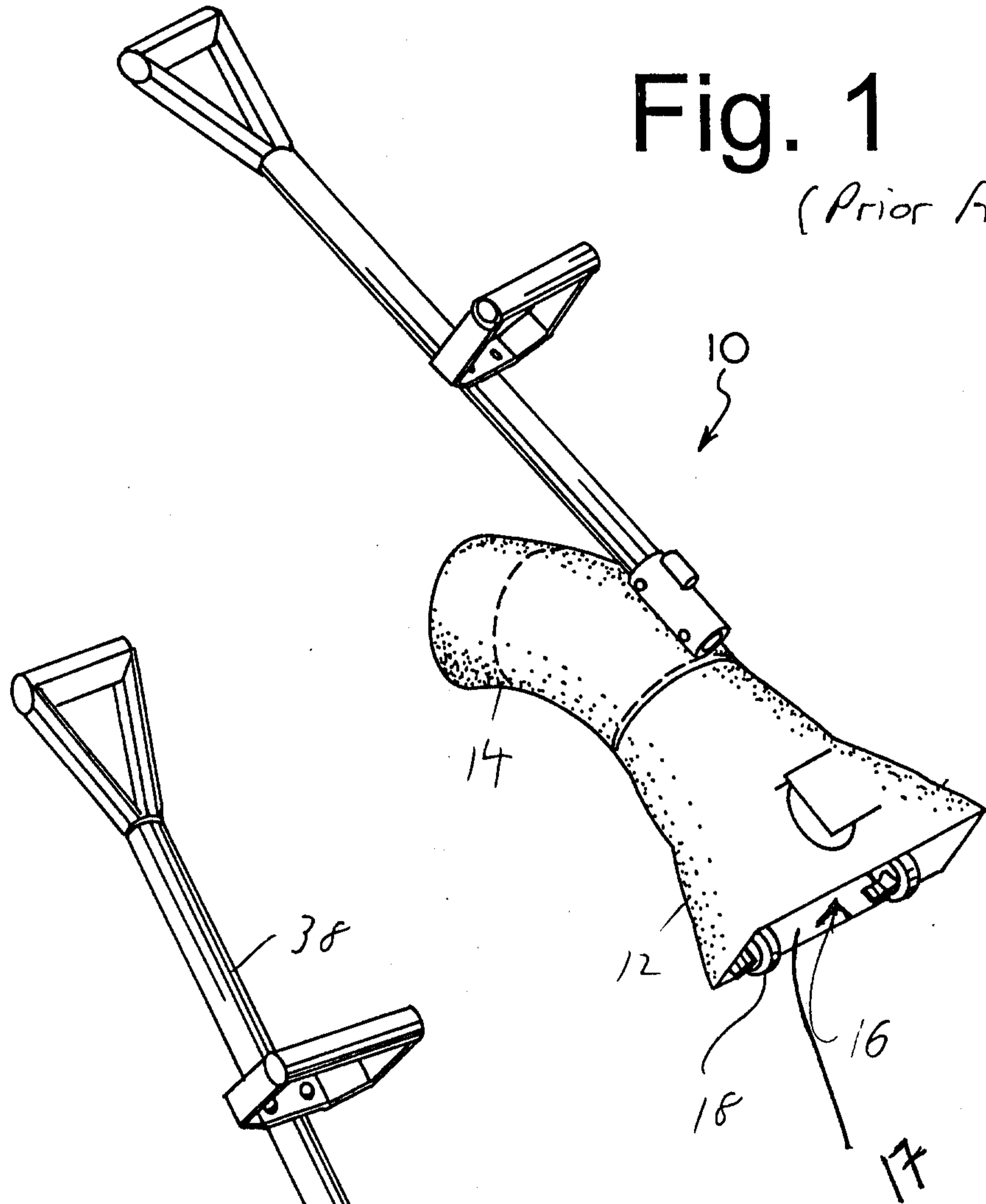
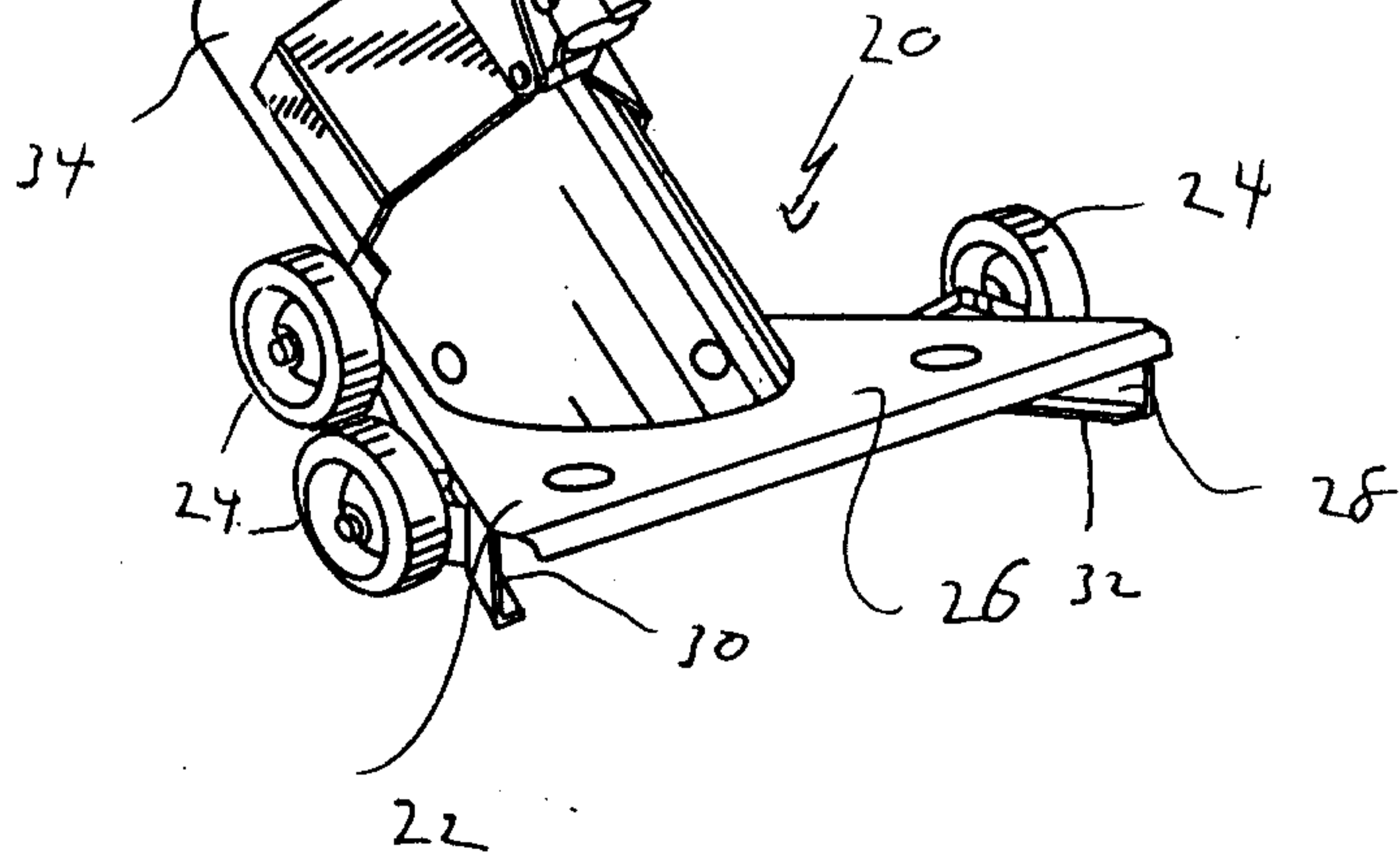
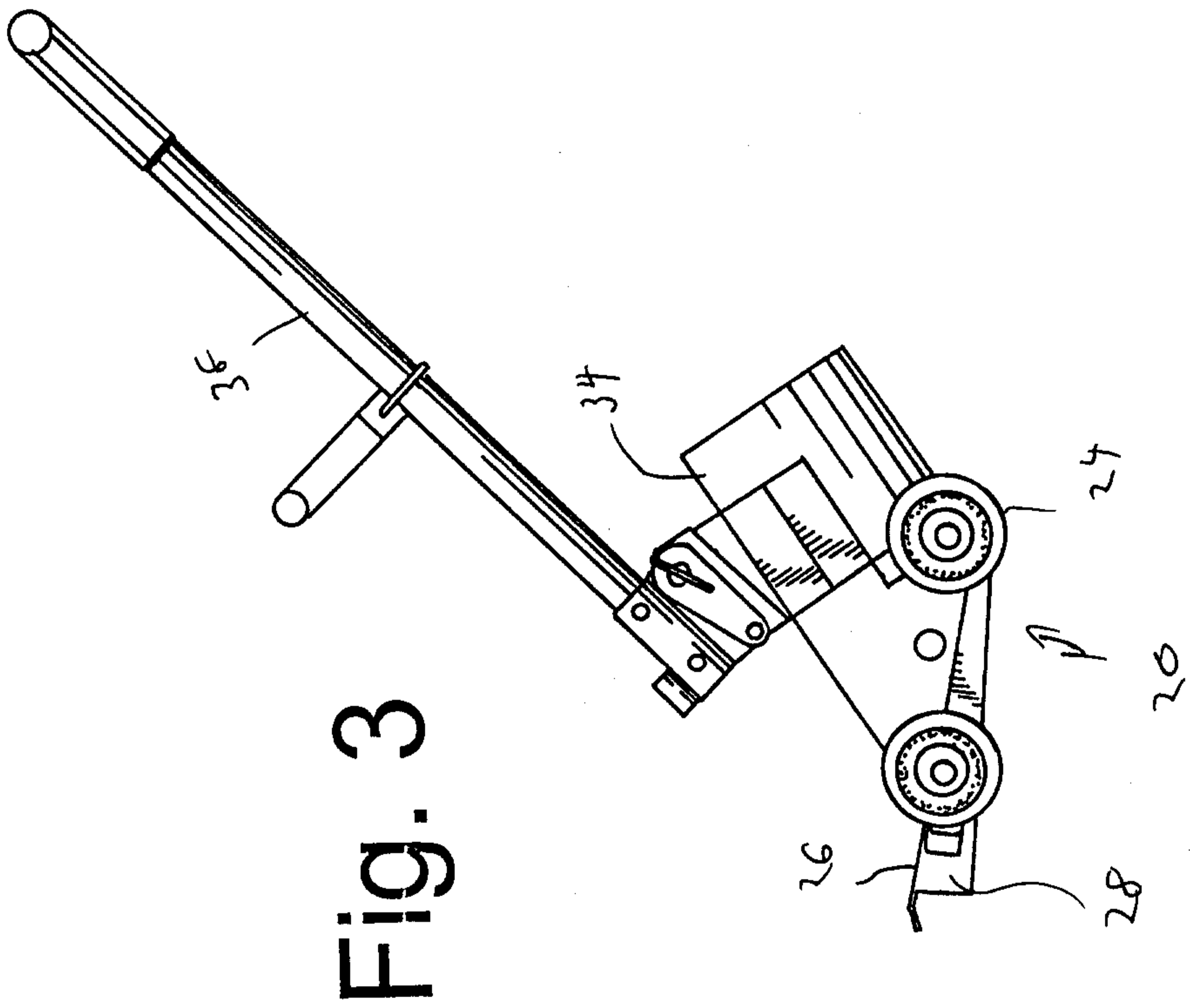
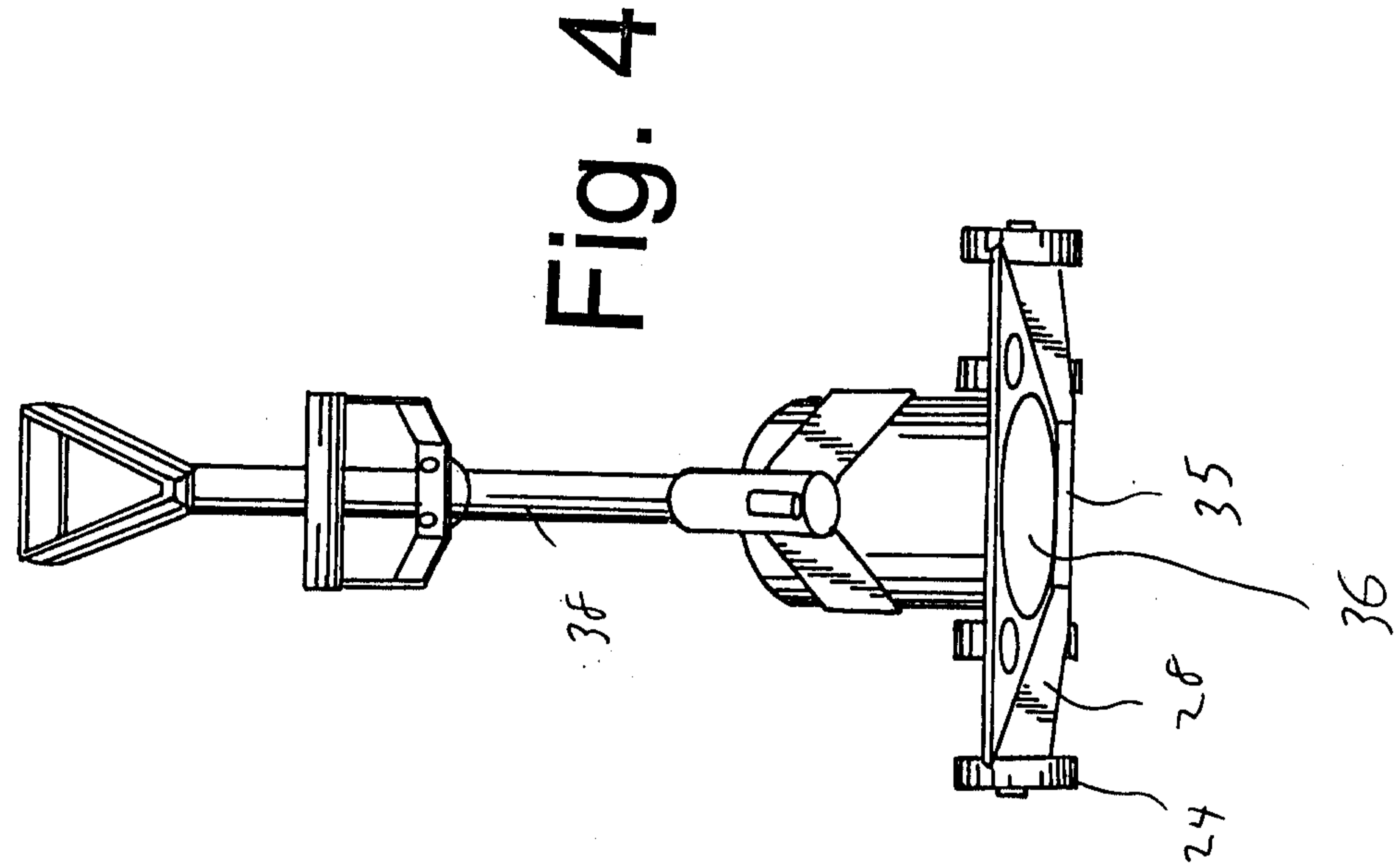

Fig. 2





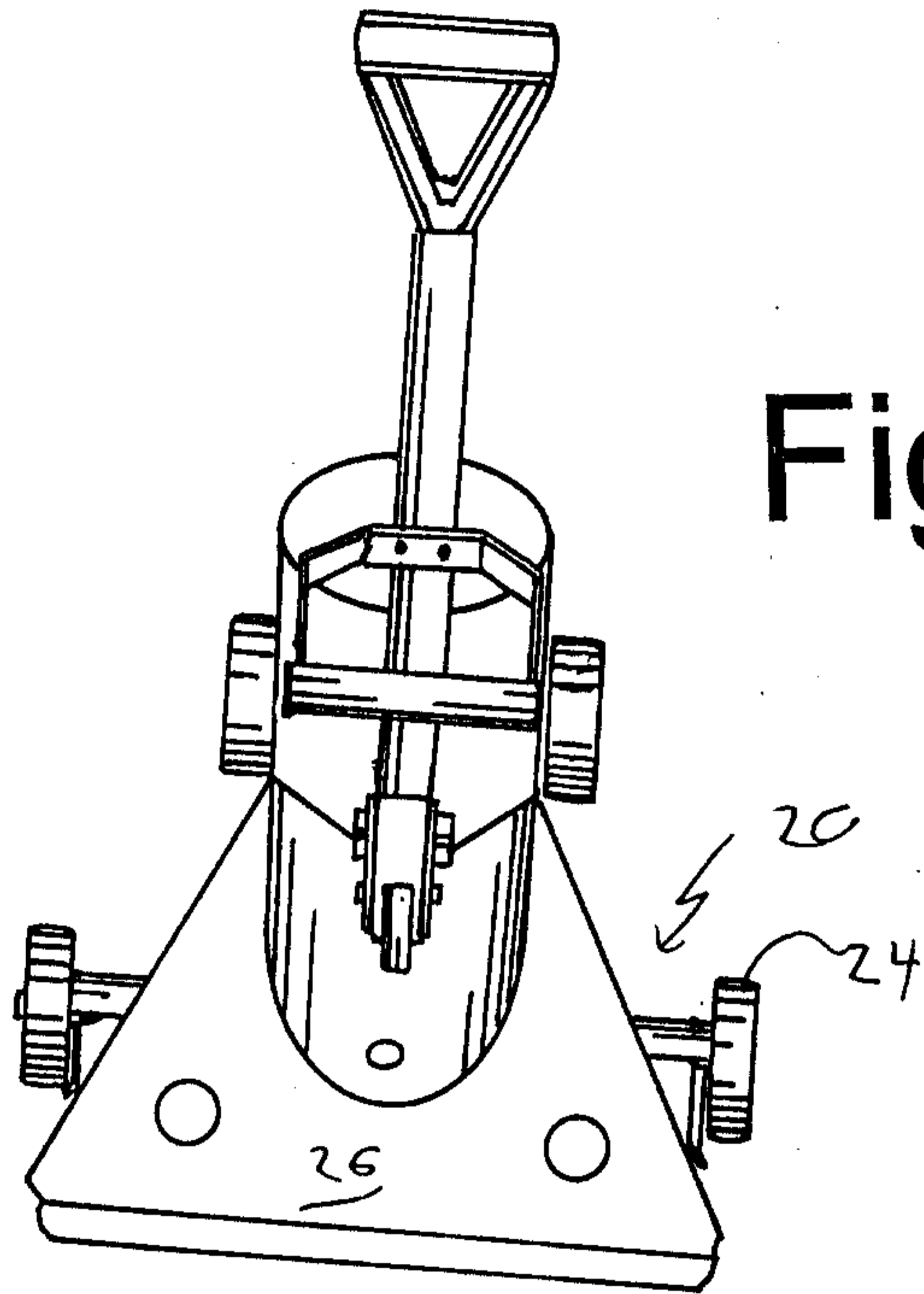

Fig. 5

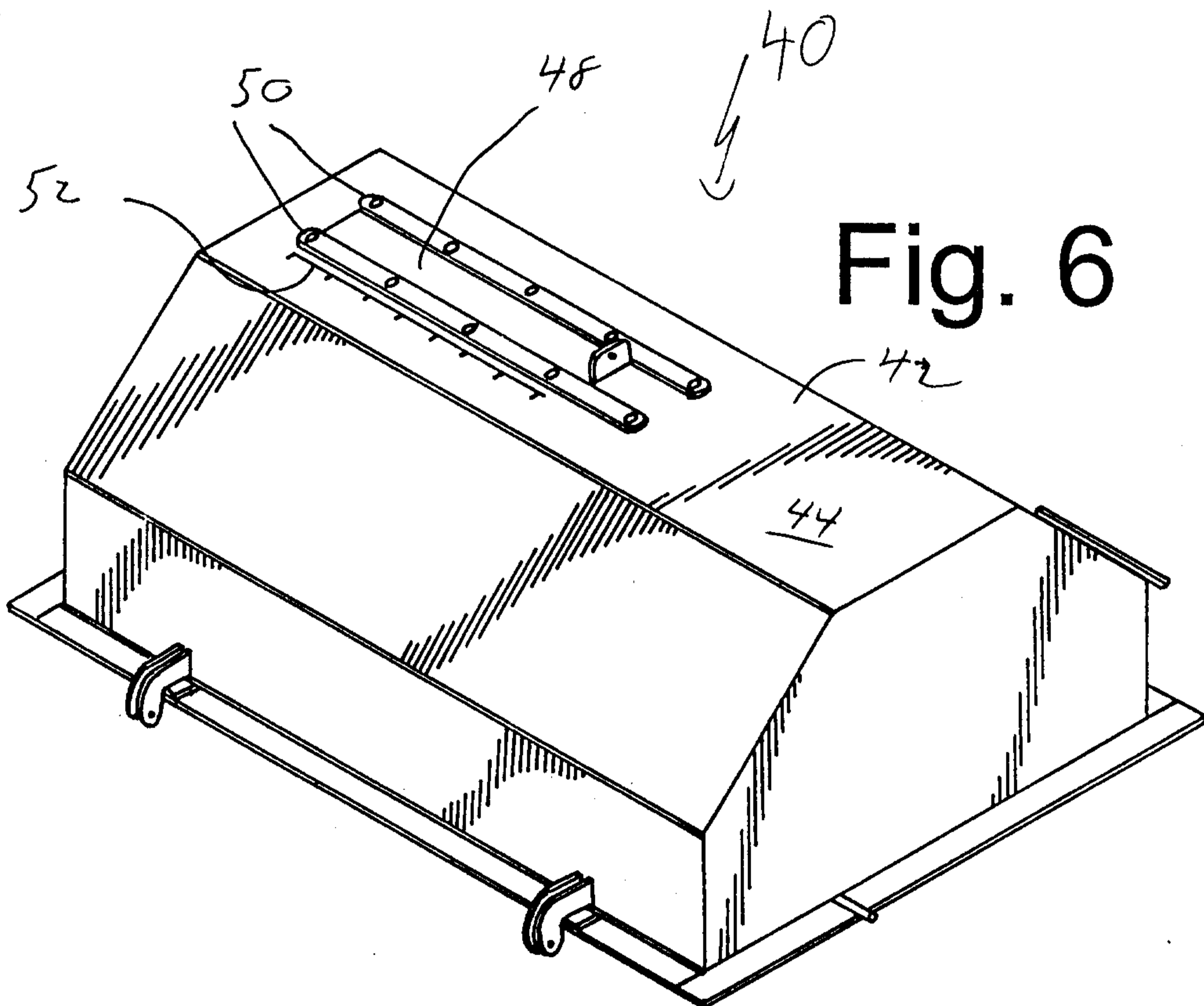

Fig. 6

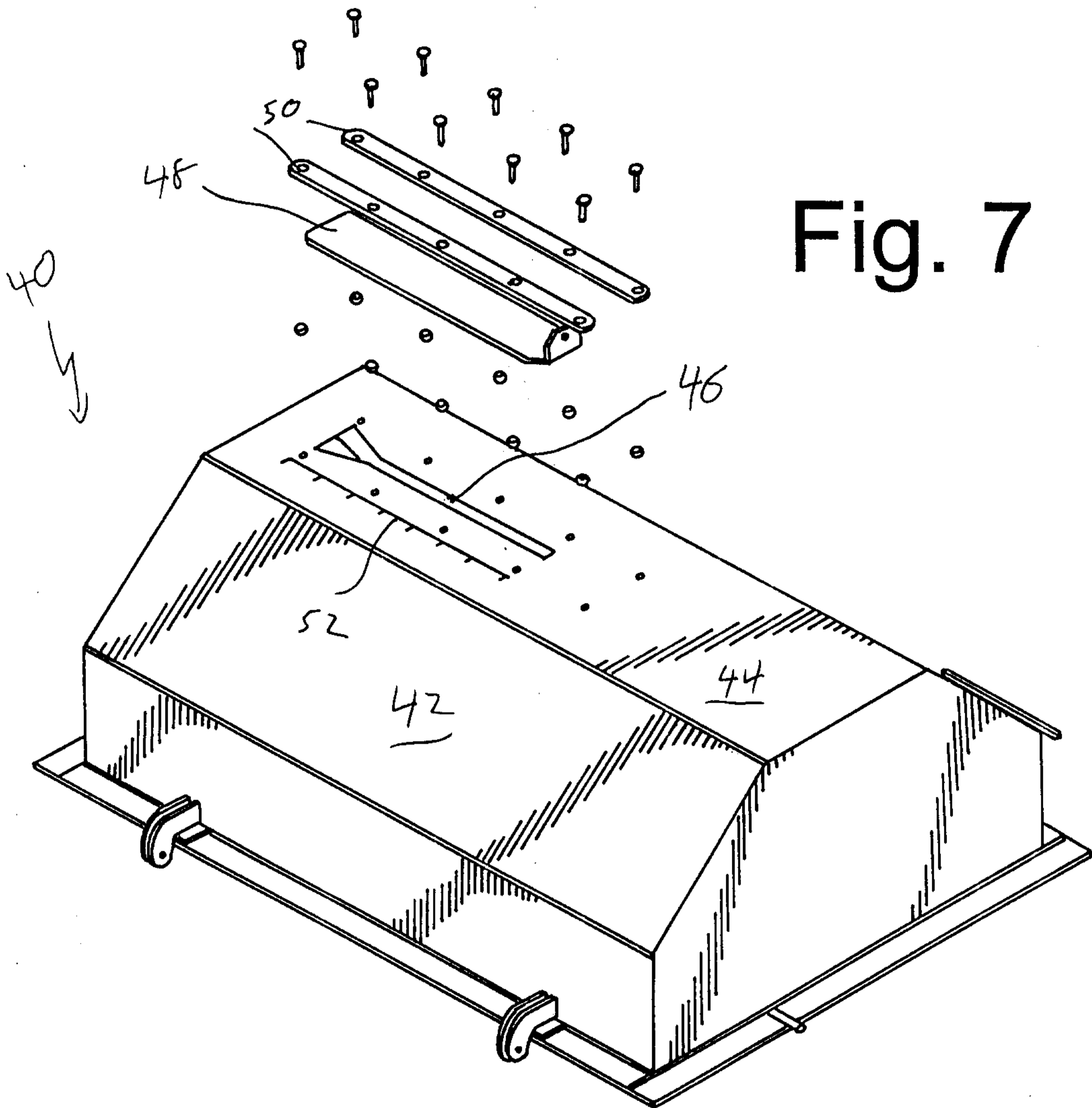

Fig. 7

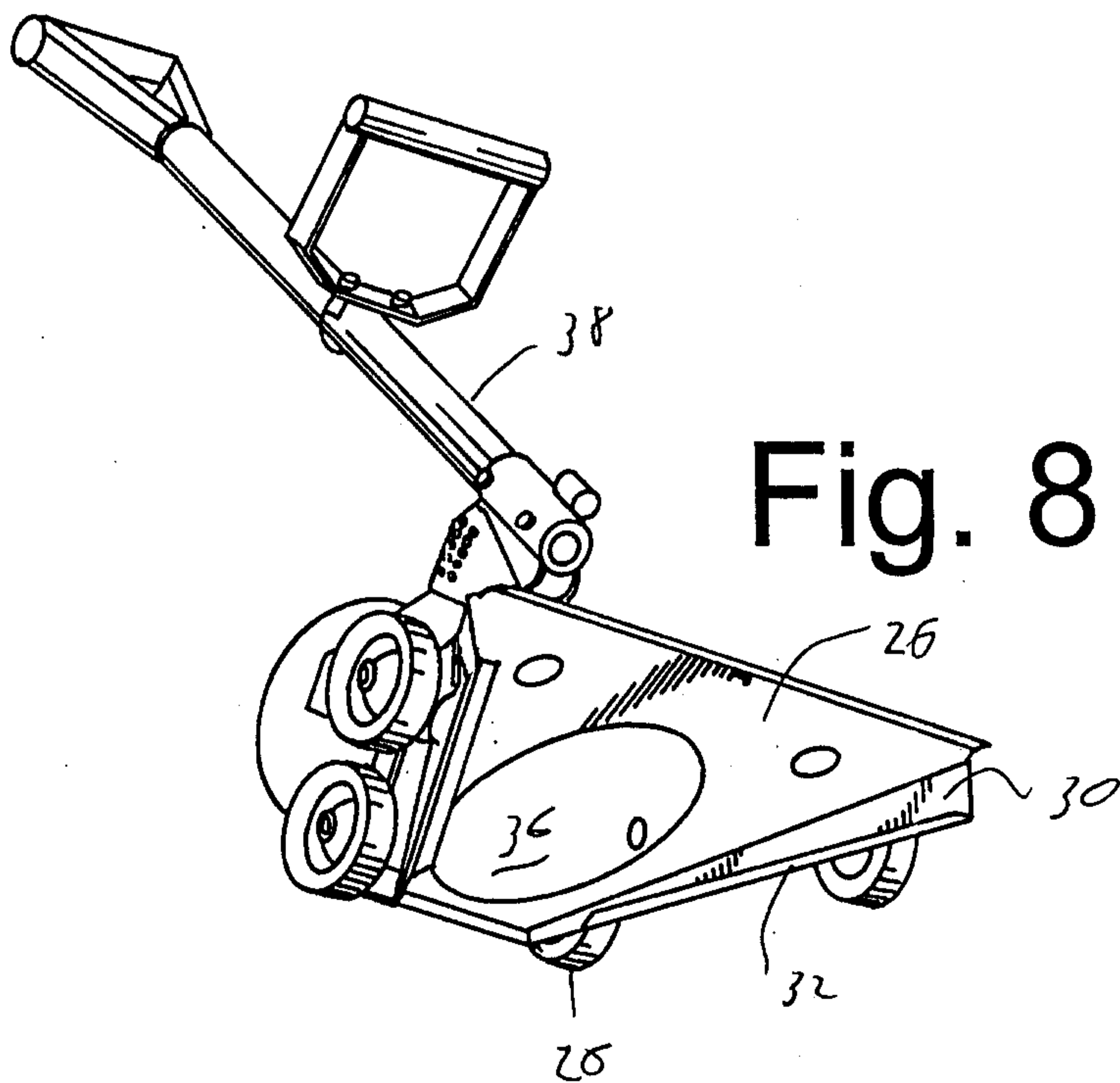

Fig. 8

