

(19) World Intellectual Property  
Organization  
International Bureau



(43) International Publication Date  
15 April 2004 (15.04.2004)

PCT

(10) International Publication Number  
WO 2004/031663 A1

- (51) International Patent Classification<sup>7</sup>: F24H 3/10, F23D 14/10
- (21) International Application Number: PCT/IT2003/000589
- (22) International Filing Date: 30 September 2003 (30.09.2003)
- (25) Filing Language: English
- (26) Publication Language: English
- (30) Priority Data: MI2002A002081 2 October 2002 (02.10.2002) IT
- (71) Applicant (for all designated States except US): **TECN-  
OCLIMA S.p.A.** [IT/IT]; Viale dell'Industria, 19, I-38057  
Pergine Valsugana (Trento) (IT).
- (72) Inventor; and
- (75) Inventor/Applicant (for US only): **VESCOVI, Alfonso**  
[IT/IT]; Via Bellavista II, 35, I-38068 Rovereto (Trento)  
(IT).
- (74) Agent: **PELLEGATTA, Ottorino**; c/o Calvani, Salvi &  
Veronelli S.r L., Piazza Duca d'Aosta, 4, I-20124 Milan  
(IT).
- (81) Designated States (national): AE, AG, AL, AM, AT, AU,  
AZ, BA, BB, BG, BR, BY, BZ, CA, CH, CN, CO, CR, CU,  
CZ, DE, DK, DM, DZ, EC, EE, ES, FI, GB, GD, GE, GH,  
GM, HR, HU, ID, IL, IN, IS, JP, KE, KG, KP, KR, KZ, LC,  
LK, LR, LS, LT, LU, LV, MA, MD, MG, MK, MN, MW,  
MX, MZ, NO, NZ, OM, PH, PL, PT, RO, RU, SC, SD, SE,  
SG, SK, SL, TJ, TM, TN, TR, TT, TZ, UA, UG, US, UZ,  
VC, VN, YU, ZA, ZM, ZW.
- (84) Designated States (regional): ARIPO patent (GH, GM,  
KE, LS, MW, MZ, SD, SL, SZ, TZ, UG, ZM, ZW),  
Eurasian patent (AM, AZ, BY, KG, KZ, MD, RU, TJ, TM),  
European patent (AT, BE, BG, CH, CY, CZ, DE, DK, EE,  
ES, FI, FR, GB, GR, HU, IE, IT, LU, MC, NL, PT, RO,  
SE, SI, SK, TR), OAPI patent (BF, BJ, CF, CG, CI, CM,  
GA, GN, GQ, GW, ML, MR, NE, SN, TD, TG).
- Published:**  
— with international search report
- For two-letter codes and other abbreviations, refer to the "Guidance Notes on Codes and Abbreviations" appearing at the beginning of each regular issue of the PCT Gazette.

(54) Title: HOT AIR GENERATOR

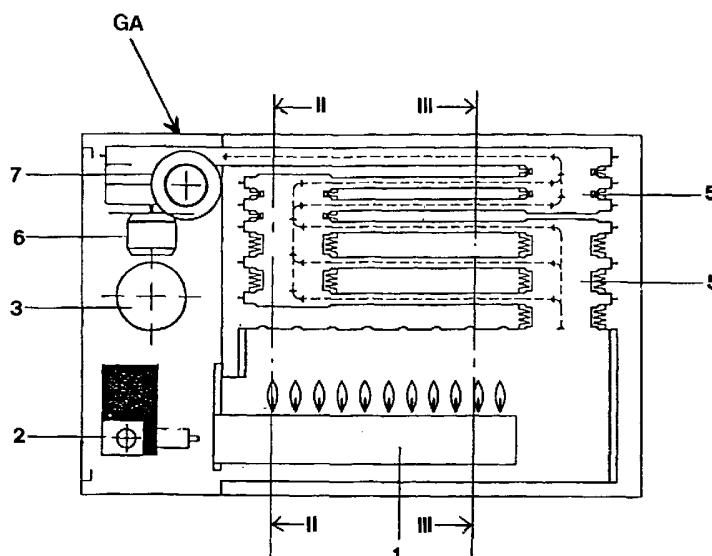

(57) Abstract: The hot air generator comprises a combustion chamber, a liquid or gas fuel burner, an air-flue gas heat exchanger, a fan providing for the forced circulation of the combustion products and a fan providing for the forced circulation of the air to be heated and is characterized in that the burner has an external surface having a curricular cross-section and a series of holes arranged on an upper semicircular arc of the external surface of the burner and having variable diameter in order to generate flames having decreasing heights from the end of the semicircular arc to the upper midpoint, and the heat exchanger is formed by arrays in series of plates connected one another in parallel, the number and distance between the plates forming each array being proportional to the inverse the temperature of the combustion products flowing into the heat exchanger, so as to keep the flow velocity of the combustion products constant.

WO 2004/031663 A1

## Description

### Hot air generator

#### Technical field

- 5 The present invention generally relates to the field of heating of industrial and civil facilities and, in particular, it relates to a new type of hot air generator.

#### Background Art

- 10 It is known that hot air generators generally comprise a combustion chamber where the combustion of a liquid or gas fuel takes place, an air-flue gas heat exchanger, a fan assembly that provides for a forced circulation of air, and a supporting frame on which the enclosure panels are applied, usually internally covered  
15 with a thermal insulating material to limit the thermal radiation from the furnace to the outside environment.

- The combustion chamber is delimited by a housing in the interior part of which a liquid or gas fuel burner is located. A manifold communicating with the combustion chamber collects the flue gas  
20 and conveys it to the heat exchanger.

- The heat exchanger is generally formed by a series of plates or tubes the surfaces of which are touched internally by the hot stream formed by the flue gas, and externally by the air stream to be heated. A final manifold collects the flue gas running through the heat  
25 exchanger and diffuses it through an outlet into the surrounding

atmosphere. The fan can be of the axial or centrifugal kind and provides for an air circulation through the heat exchanger. Air in contact with the heat exchanger is heated and sent back to the surrounding environment.

5 Hot air generators of this type, which are manufactured in accordance with the known art, generally have some defects relating both to their design and to their thermal efficiency. More particularly, as far as the design of the hot air generators known in the art is concerned, it is worth noting that the plates or pipes of the heat  
10 exchanger are generally welded, thus requiring rather a long manufacturing time and high costs. In addition, before using the semi finished parts of the heat exchanger, an accurate quality check of the welding must be performed, thus further increasing the cost of the semi finished parts. As to heat exchange, it should be noted that the  
15 hot air generators known in the art generally show a modest efficiency because the heat exchange is penalized by the circumstance that the flue gas velocity inside the heat exchanger is not constant, but decreases instead in direct proportion with respect to the specific volume, thus decreasing the efficiency of the heat  
20 exchange.

### **Disclosure of Invention**

The purpose of the present invention is to provide a hot air generator of new type having a number of novel characteristics capable of improving both its design and its performance. According  
25 to this invention, the hot air generator comprises a combustion

chamber, a liquid or gas fuel burner, an air-flue gas heat exchanger, a fan providing for the forced circulation of the combustion products and a fan providing for the forced circulation of the air to be heated, and is characterized in that:

- 5           - the burner has an external surface having a circular cross-section and a series of holes arranged on an upper semicircular arc of the external surface and having variable diameter in order to generate flames having decreasing heights from the end of the semicircular arc to the upper
- 10           midpoint, and
- the heat exchanger is formed by arrays in series of plates mutually connected in parallel, the number and distance between the plates forming each array being proportional to the inverse of the temperature of the combustion products
- 15           flowing into the heat exchanger, so as to keep the velocity of the combustion products constant.

#### **Brief description of drawings**

The invention will now be described in more detail with reference

20 to the attached drawings, in which:

Figure 1 is a side elevation view of the interior of the hot air generator according to the present invention,

Figure 2 is a cross-section view of the hot air generator along line II-II of figure 1,

Figure 3 is a cross-section view of the hot air generator along line III-III of figure 1,

Figure 4 is a longitudinal section view of the burner of the hot air generator according to the present invention,

5 Figure 5 is a cross-section view of the burner of the hot air generator along line V-V of figure 4,

Figures 6 and 7 are a plan view of the upper part, respectively of the lower part, of a plate of the heat exchanger of the hot air generator of the present invention,

10 Figure 8 is a cross-section view of the plate of figure 6 taken along line VIII-VIII of figure 6,

Figure 9 is a longitudinal view of the plate of figure 6 taken along line IX-IX of figure 6,

15 Figure 10 is a section view of a connection element between a pair of plates of the heat exchanger of the hot air generator according to the present invention,

Figure 11 is a partial section view of the connection element of figure 10,

20 Figure 12 is a plan view of the connection element of figure 11, and

Figure 13 is a longitudinal section partial view of the heat exchanger of the hot air generator according to the present invention.

**Best mode for carrying out the Invention**

Referring now to figures 1, 2 and 3, these figures show a hot air generator according to the present invention, indicated generally with GA.

The hot air generator comprises an atmospheric type liquid or gas fuel burner 1 mixing a correct amount of fuel, fed by an electrical valve 2, with oxygen contained in air taken in through intake connector 3 and creating a radial type flame 9. Gases produced by the combustion, after an inversion of their stream inside the combustion chamber 4, are conveyed to successive arrays of elements of flue gas exchange pipes, connected in parallel and forming an horizontal exchanger 5. The combustion products are sucked through a centrifugal type fan 6 and, after having transferred their heat to the air inside the heat exchanger, they are ejected outside through the outlet connector 7. Air to be heated is forced through the heat exchanger by an axial or centrifugal type fan 8 and streams along the surface of the heat exchanger, warming up in contact therewith.

Figures 4 and 5 show a burner of the hot air generator according to the present invention. The burner 1 internally exhibits a Venturi pipe 10 having such a geometry as to permit operation with a prevailing amount of primary air P and reduced amount of secondary air S. In addition, the external surface 11 of burner 1 shows a series of holes 12 having variable diameter, so as to permit the formation of a flame distributed along a semicircular arc of the burner cross-section and to display a maximum height of the flame at the extremity

of the semicircular arc and a minimum height of the flame at the midpoint of the semicircular arc. In this way, an efficient heat distribution is achieved inside the combustion chamber 4.

Figures from 6 to 9 show a plate 13 of the heat exchanger. Plate 5 13 has a series of cross type turbulence inducing imprints 14 for the gas that assure high efficiency and limited loss of pressure and a pair of buckling preventing spacing imprints 15 that allow to keep the upper and lower parts of the plate mutually spaced. In order to facilitate the plate assembly, height sizing imprints 16 are provided as 10 well as circular connection connections 17 for the mutual connection of the plates in order to form the heat exchanger.

Figures from 10 to 12 show the connection element 18 that allows mutual connection of a pair of plates 13 of the heat exchanger horizontally placed one on top of the other. This connection element 15 18 assures a seal to the plates 13 even in the absence of welding. The connection element shows heat dissipating fins 19 as well as a tapered portion 20 having a wide contact surface. The connection element is configured in such a way as to act as a manifold for the combustion products flowing from the lower to the upper plate of the 20 heat exchanger. The connection between the plates of the heat exchanger is obtained through pressure contact between the surfaces of plates 13 and that of the connection element 18. The circular drawing of plates 13 is carried out on the external surface in order to provide for an efficient cooling of the material, an excellent 25 mechanical resistance to compressive stress and a low pressure

loss. In addition, because of the conical shape of the drawing, the contact surface with the connection element is as wide as possible and allows to offset normal manufacturing tolerances.

As it can be seen from figure 13, the compressive force holding  
5 together the plates of the heat exchanger is achieved through springs  
21, tie bolts 22 and spacers 23. The tie bolt 22, together with spacers  
23, assures a correct positioning of plates 13 at a fixed mutual  
distance and the springs 21 surrounding tie bolts 22 provide for a  
constant lateral compressive force on plates 13, offsetting normal  
10 expansions originating from temperature changes.

According to the present invention, it is possible to change the  
number and distance of the plates forming each array in order to  
keep the velocity constant of the combustion products when their  
temperature and specific volume decrease, as a result of the thermal  
15 exchange with air. This allows to maximize the performance of the  
thermal exchange and to gear the heat exchanger to different  
requirements of thermal exchange.

### Claims

1. Hot air generator comprising a combustion chamber, a liquid or gas fuel burner, an air-flue gas heat exchanger, a fan providing for the forced circulation of the combustion products and a fan providing for the forced circulation of the air to be heated, characterized in that:
- the burner has an external surface having a circular cross-section and a series of holes arranged on an upper semicircular arc of the external surface of the burner and having variable diameter in order to generate flames having decreasing heights from the end of the semicircular arc to the upper midpoint, and
  - the heat exchanger is formed by arrays in series of plates mutually connected in parallel, the number and distance between the plates forming each array being proportional to the inverse of the temperature of the combustion products flowing into the heat exchanger so as to keep the flow velocity of the combustion products constant.
2. Hot air generator according to claim 1, characterized in that the plates of each array of the heat exchanger are mutually connected by connection elements located at the outlet and inlet openings of the combustion products in the plate and are kept into contact with the connection elements by means of the compression applied by tie bolts provided with

compression springs and kept at a fixed mutual distance by spacers.

- 5
3. Hot air generator according to claim 1, characterized in that the plates of the heat exchanger have cross type turbulence inducing imprints in order to increase the efficiency of the thermal exchange between combustion products and air to be heated.
- 10
4. Hot air generator according to claim 3, characterized in that the cross type turbulence inducing imprints have an elongated shape.
5. Hot air generator according to claim 1, characterized in that the fan is a suction fan.
6. Hot air generator according to claim 1, characterized in that the fan is a pusher fan.

**FIG. 1**

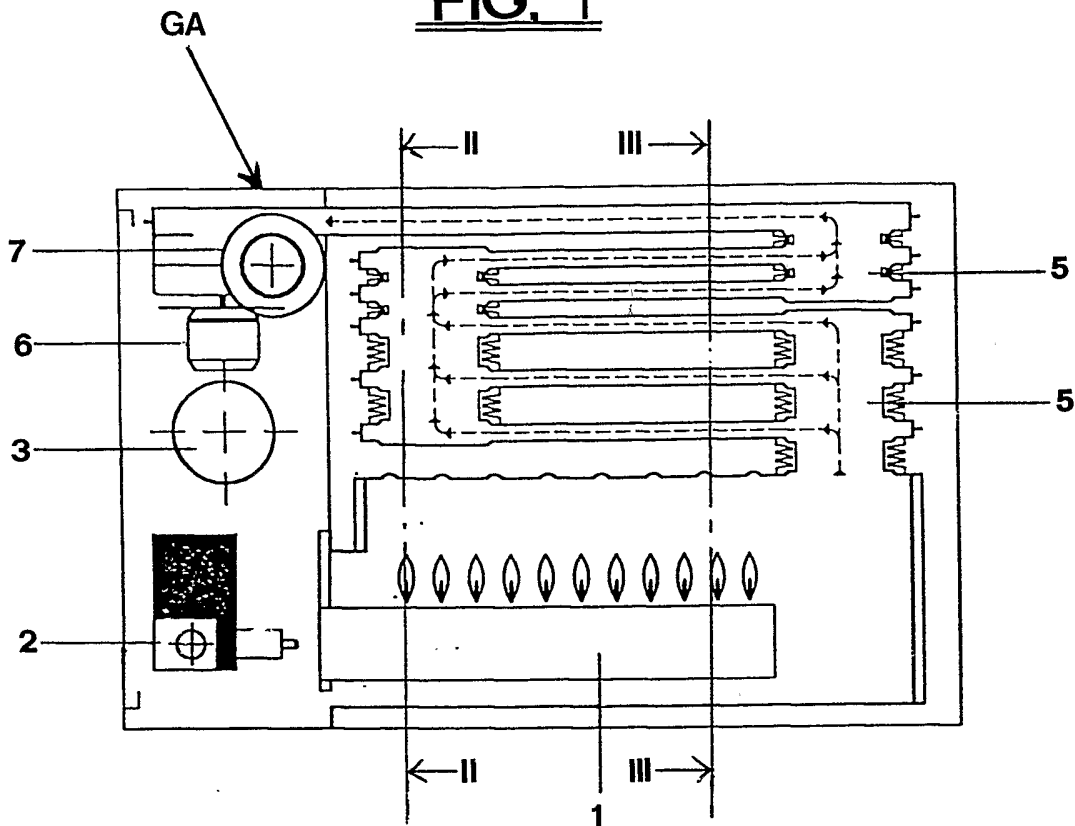

**FIG. 2**

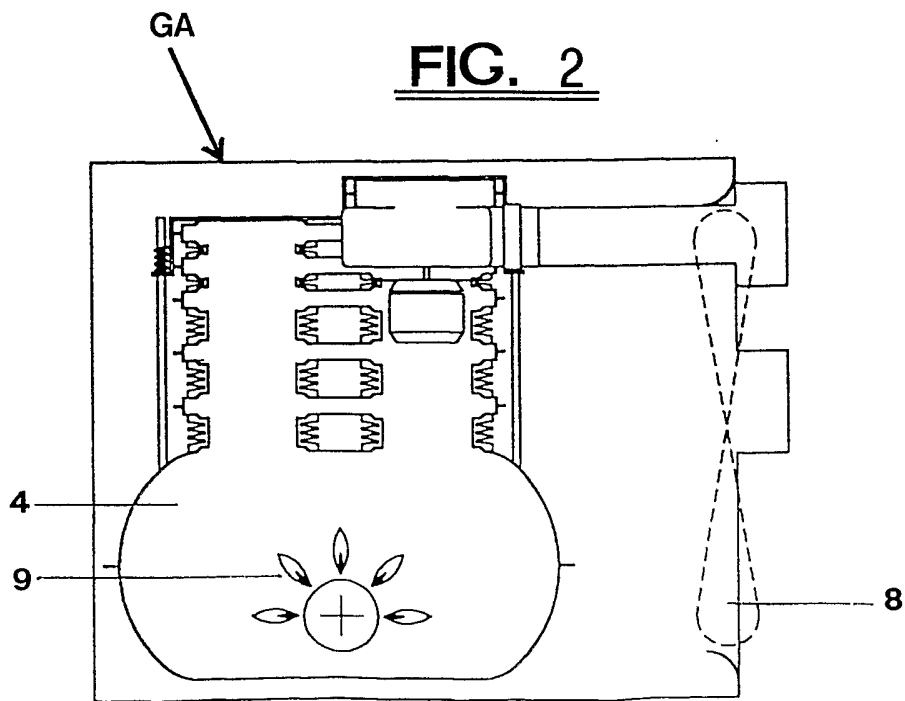
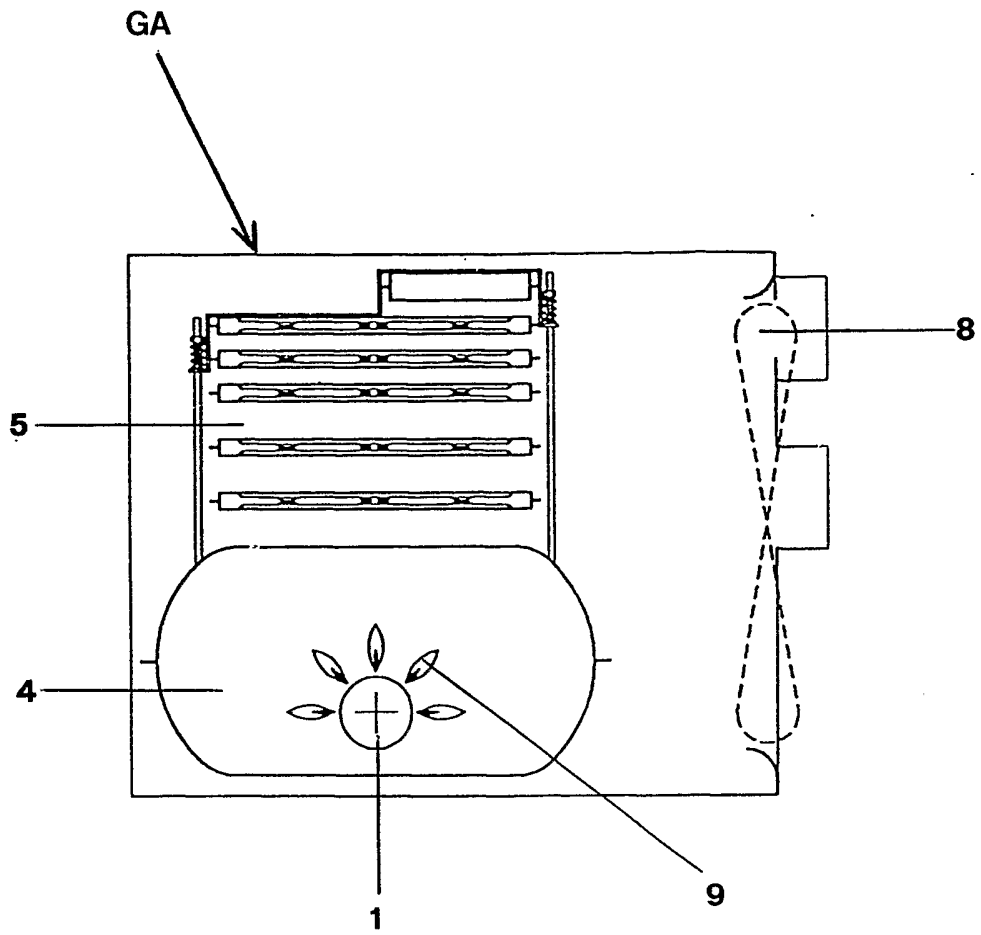
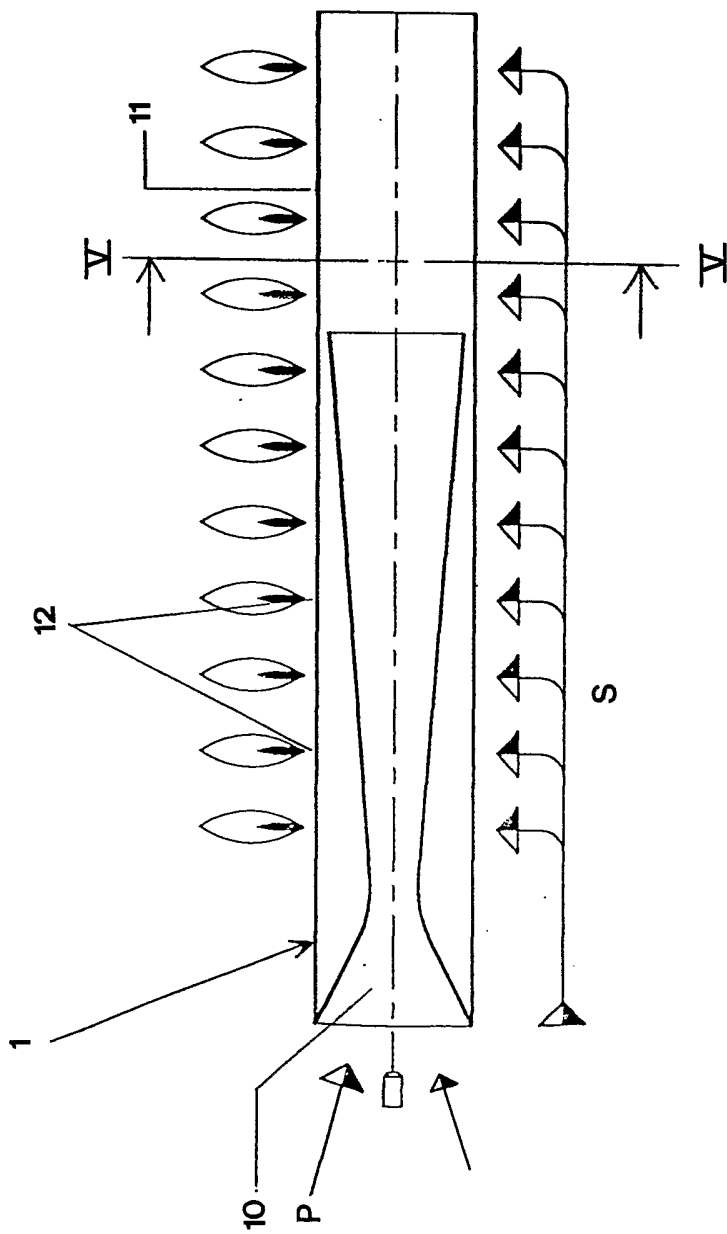

FIG. 3



**FIG. 4**



**FIG. 5**

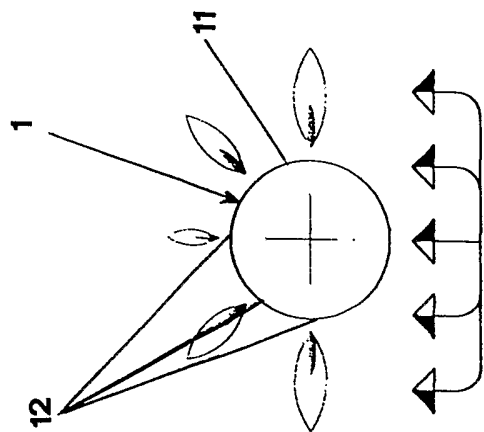

FIG. 6

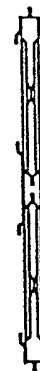
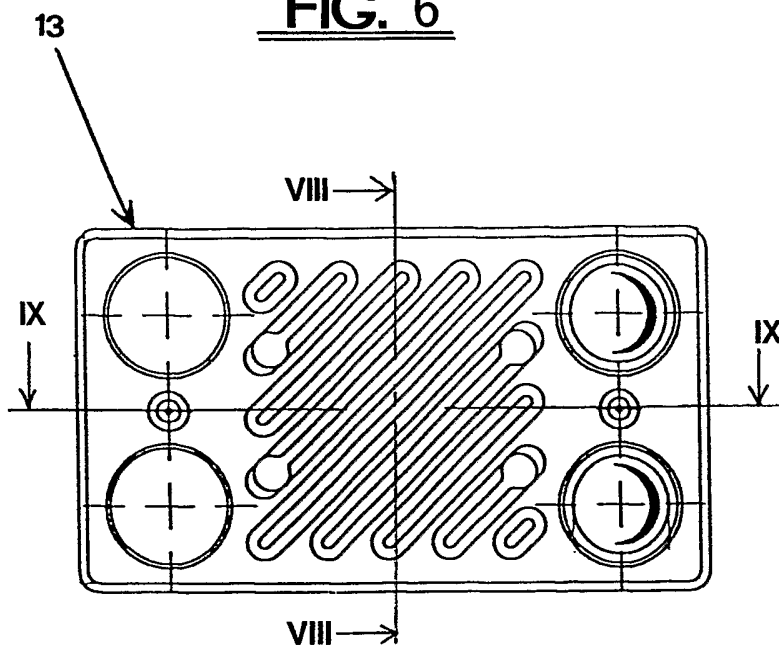

FIG. 8

FIG. 9

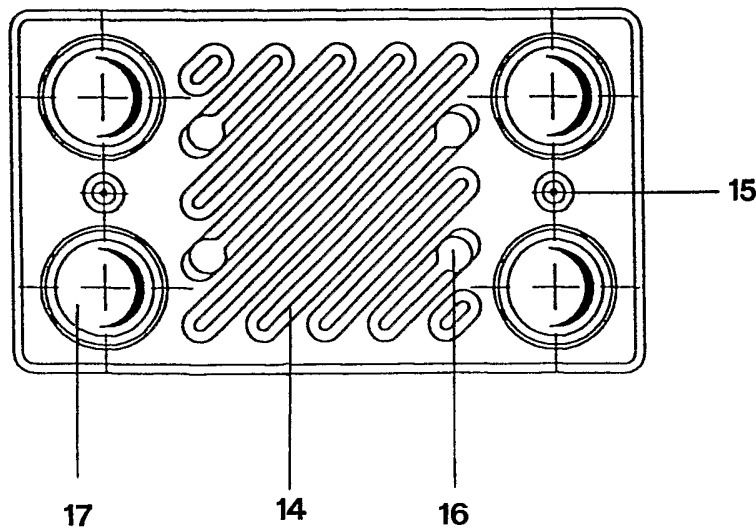
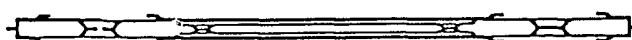

FIG. 7

FIG. 10

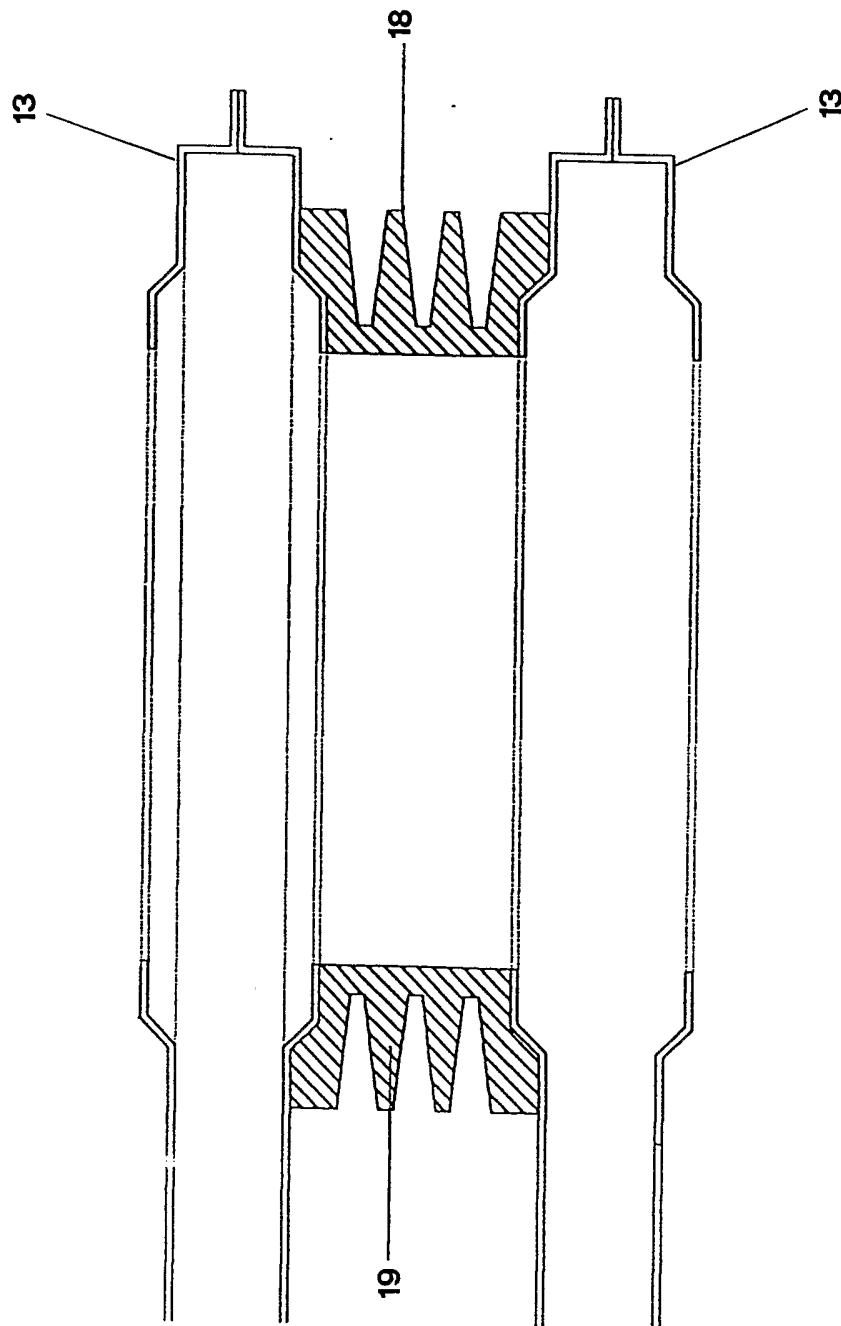

FIG. 12

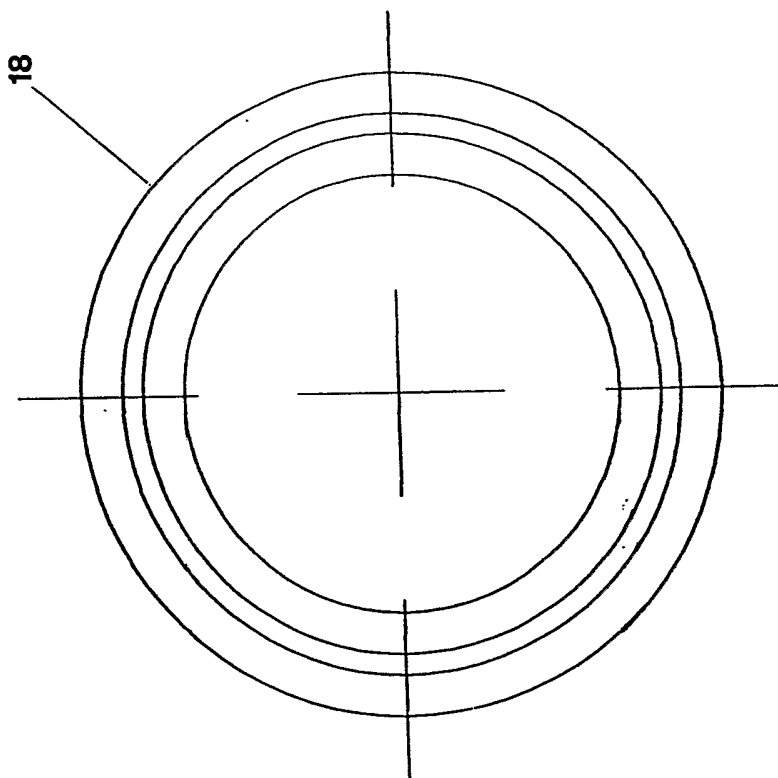

FIG. 11

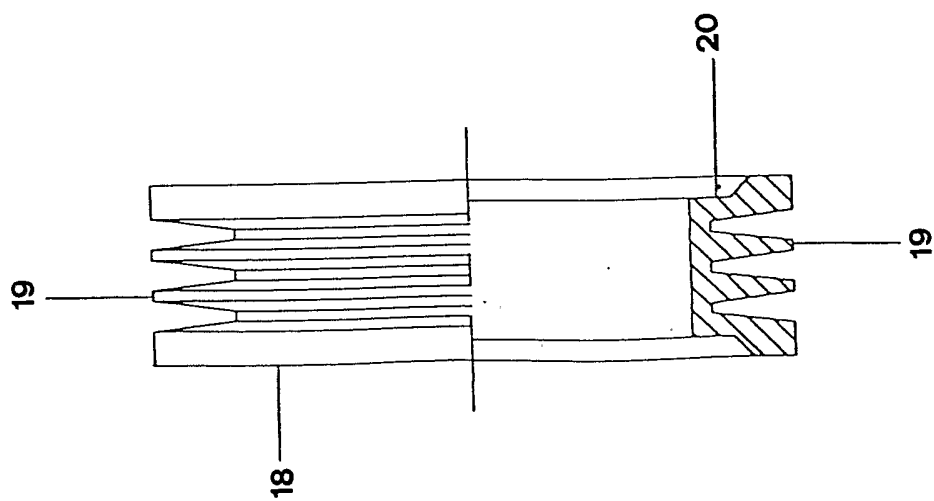
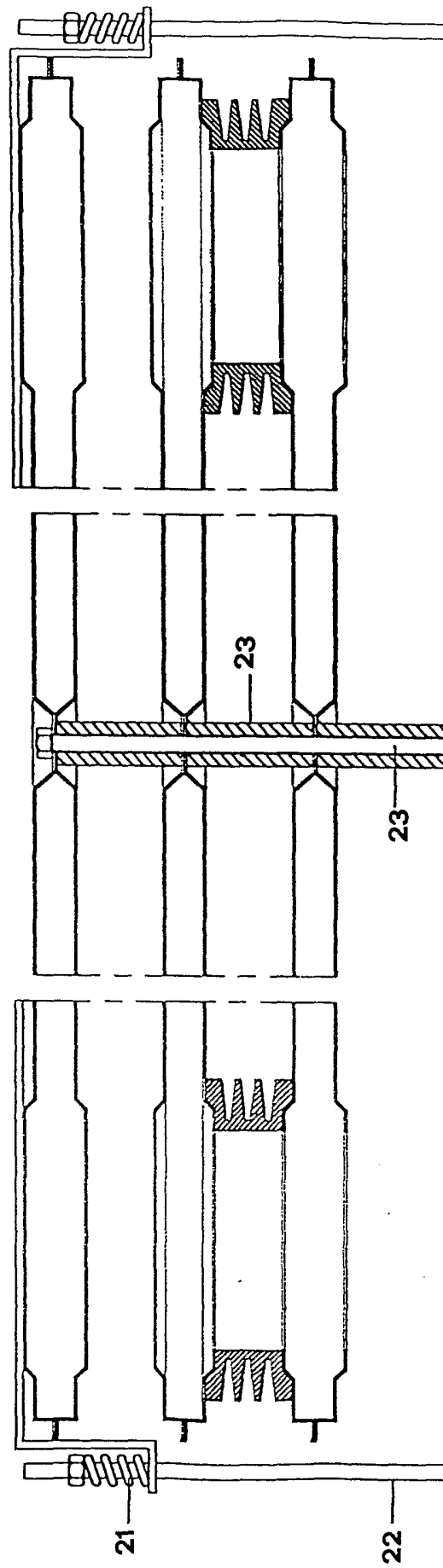

FIG. 13



# INTERNATIONAL SEARCH REPORT

International Application No

PCT/IT 03/00589

**A. CLASSIFICATION OF SUBJECT MATTER**  
 IPC 7 F24H3/10 F23D14/10

According to International Patent Classification (IPC) or to both national classification and IPC

**B. FIELDS SEARCHED**

Minimum documentation searched (classification system followed by classification symbols)

IPC 7 F24H F23D F28D

Documentation searched other than minimum documentation to the extent that such documents are included in the fields searched

Electronic data base consulted during the international search (name of data base and, where practical, search terms used)

EPO-Internal

**C. DOCUMENTS CONSIDERED TO BE RELEVANT**

Category °	Citation of document, with indication, where appropriate, of the relevant passages	Relevant to claim No.
Y	EP 0 431 446 A (TECNOCLIMA SPA) 12 June 1991 (1991-06-12) column 4, line 13 - line 18 column 4, line 42 - line 44 column 56, line 11 - line 16 figures 1,2 ---	1
Y	WO 89 01116 A (WORGAS BRUCIATORI SRL) 9 February 1989 (1989-02-09) claim 12; figure 2 ---	1
A	DE 199 39 017 A (WALTER KROLL GMBH WAERME UND U) 22 February 2001 (2001-02-22) column 3, line 20 - line 29 figures 1-3 --- -/--	2

Further documents are listed in the continuation of box C.

Patent family members are listed in annex.

° Special categories of cited documents :

- \*A\* document defining the general state of the art which is not considered to be of particular relevance
- \*E\* earlier document but published on or after the international filing date
- \*L\* document which may throw doubts on priority claim(s) or which is cited to establish the publication date of another citation or other special reason (as specified)
- \*O\* document referring to an oral disclosure, use, exhibition or other means
- \*P\* document published prior to the international filing date but later than the priority date claimed

- \*T\* later document published after the international filing date or priority date and not in conflict with the application but cited to understand the principle or theory underlying the invention
- \*X\* document of particular relevance; the claimed invention cannot be considered novel or cannot be considered to involve an inventive step when the document is taken alone
- \*Y\* document of particular relevance; the claimed invention cannot be considered to involve an inventive step when the document is combined with one or more other such documents, such combination being obvious to a person skilled in the art.
- \*&\* document member of the same patent family

Date of the actual completion of the international search

14 January 2004

Date of mailing of the international search report

29/01/2004

Name and mailing address of the ISA  
 European Patent Office, P.B. 5818 Patentlaan 2  
 NL - 2280 HV Rijswijk  
 Tel. (+31-70) 340-2040, Tx. 31 651 epo nl,  
 Fax: (+31-70) 340-3016

Authorized officer

García Moncayo, O

## INTERNATIONAL SEARCH REPORT

International Application No

PCT/IT 03/00589

C.(Continuation) DOCUMENTS CONSIDERED TO BE RELEVANT		
Category °	Citation of document, with indication, where appropriate, of the relevant passages	Relevant to claim No.
A	US 5 113 844 A (COOK ROBERT W) 19 May 1992 (1992-05-19) figures 5,6 ----	3,4
A	US 3 397 742 A (BENGT-AKE OHLSSON ET AL) 20 August 1968 (1968-08-20) column 1, line 1 -column 2, line 39; figures 1-16 ---	1
A	US 4 106 474 A (HUNTER ROBERT L ET AL) 15 August 1978 (1978-08-15) figures 1,2 ---	1
A	US 6 129 545 A (KAHLKE MICHAEL ET AL) 10 October 2000 (2000-10-10) column 6, line 32 - line 47; figures 1,2B,3A ---	
A	GB 670 337 A (MAIN WATER HEATERS LTD) 16 April 1952 (1952-04-16) figures 1,2 ---	1
A	US 3 780 954 A (GENBAUFFS F) 25 December 1973 (1973-12-25) figures 2,7 ---	1
A	US 5 359 989 A (CHASE THOMAS ET AL) 1 November 1994 (1994-11-01) column 1, line 34 - line 37 column 1, line 64 -column 2, line 27 claim 1; figure 5 -----	1

## INTERNATIONAL SEARCH REPORT

International Application No

PCT/IT 03/00589

Patent document cited in search report		Publication date	Patent family member(s)	Publication date
EP 0431446	A	12-06-1991	IT 219055 Z2	27-11-1992
			AT 95298 T	15-10-1993
			DE 69003657 D1	04-11-1993
			DE 69003657 T2	10-02-1994
			EP 0431446 A1	12-06-1991
			ES 2045728 T3	16-01-1994
WO 8901116	A	09-02-1989	WO 8901116 A1	09-02-1989
			AT 95905 T	15-10-1993
			AU 627146 B2	20-08-1992
			AU 7809187 A	01-03-1989
			BR 8707991 A	22-05-1990
			DE 3787810 T2	14-04-1994
			EP 0373157 A1	20-06-1990
			JP 2501496 T	24-05-1990
			RO 114675 B1	30-06-1999
			RU 2002994 C1	15-11-1993
DE 19939017	A	22-02-2001	DE 19939017 A1	22-02-2001
			AU 6996300 A	13-03-2001
			WO 0113047 A2	22-02-2001
US 5113844	A	19-05-1992	AU 624662 B2	18-06-1992
			AU 4619489 A	14-06-1990
			WO 9007091 A1	28-06-1990
US 3397742	A	20-08-1968	SE 301817 B	24-06-1968
			DE 1501441 A1	13-11-1969
			FI 43201 B	02-11-1970
			GB 1094366 A	13-12-1967
			NL 6517081 A	30-06-1966
			NO 120428 B	19-10-1970
US 4106474	A	15-08-1978	CA 1076440 A1	29-04-1980
US 6129545	A	10-10-2000	DE 19648808 A1	04-06-1998
			AT 243829 T	15-07-2003
			DE 59710342 D1	31-07-2003
			EP 0852316 A2	08-07-1998
			JP 10160128 A	19-06-1998
			PL 323340 A1	08-06-1998
GB 670337	A	16-04-1952	NONE	
US 3780954	A	25-12-1973	US 3647146 A	07-03-1972
			US 3768131 A	30-10-1973
US 5359989	A	01-11-1994	CA 2096372 A1	05-09-1994